



Improved Low-Power, CMOS Analog Switches with Latches

General Description

Maxim's redesigned DG421/DG423/DG425 monolithic analog switches now feature guaranteed on-resistance matching (3Ω max) between switches and on-resistance flatness over the signal range (4Ω max). These low on-resistance switches (20Ω typ) conduct equally well in both directions. They guarantee a low charge injection of 15pC maximum and an ESD tolerance of 2000V minimum per Method 3015.7. Off leakage current over temperature has also been reduced (less than 5nA at $+85^\circ\text{C}$).

The DG421/DG423/DG425 are precision, dual CMOS switches with latchable logic inputs that simplify interfacing with microprocessors (μPs). The single-pole/single-throw DG421 and double-pole/single-throw DG425 are normally open dual switches. The dual, single-pole/double-throw DG423 has two normally open and two normally closed switches. Fast switching times (175ns for t_{ON} and 145ns for t_{OFF}) and low power consumption ($35\mu\text{W}$ max) make these parts ideal for battery-powered applications requiring μP -compatible switches. Operation is from a single +10V to +30V supply, or bipolar $\pm 4.5\text{V}$ to $\pm 20\text{V}$ supplies. Fabricated with the same 44V silicon-gate process, these switches have rail-to-rail signal handling capabilities.

Applications

Sample-and-Hold Circuits	Modems
Fax Machines	Test Equipment
Battery-Operated Systems	PBX, PABX
Guidance and Control Systems	Military Radios
Audio Signal Routing	Communication Systems

Functional Diagrams/Truth Tables

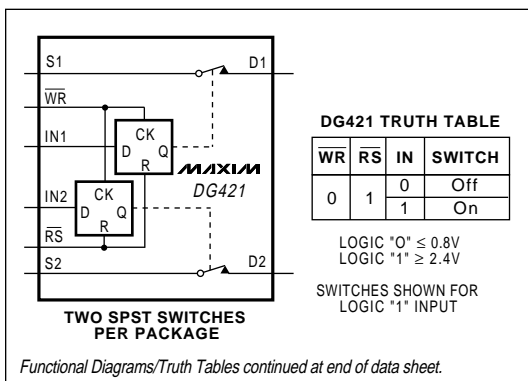

New Features

- ♦ Plug-In Upgrades for Industry-Standard DG421/DG423/DG425
- ♦ Improved $r_{\text{DS(ON)}}$ Match Between Channels (3Ω max)
- ♦ Guaranteed $r_{\text{FLAT(ON)}}$ Over Signal Range (4Ω max)
- ♦ Improved Charge Injection (15pC max)
- ♦ Improved Off Leakage Current Over Temperature ($<5\text{nA}$ at $+85^\circ\text{C}$)
- ♦ Withstands Electrostatic Discharge (2000V min) per Method 3015.7

Existing Features

- ♦ Low $r_{\text{DS(ON)}}$ (35Ω max)
- ♦ Single-Supply Operation +10V to +30V
Bipolar-Supply Operation $\pm 4.5\text{V}$ to $\pm 20\text{V}$
- ♦ Low Power Consumption ($35\mu\text{W}$ max)
- ♦ Rail-to-Rail Signal Handling Capability
- ♦ TTL/CMOS-Logic Compatible

Ordering Information

PART	TEMP. RANGE	PIN-PACKAGE
DG421CJ	0°C to $+70^\circ\text{C}$	16 Plastic DIP
DG421CY	0°C to $+70^\circ\text{C}$	16 SO
DG421C/D	0°C to $+70^\circ\text{C}$	Dice*
DG421DJ	-40°C to $+85^\circ\text{C}$	16 Plastic DIP
DG421DY	-40°C to $+85^\circ\text{C}$	16 SO
DG421DK	-40°C to $+85^\circ\text{C}$	16 CERDIP
DG421AK	-55°C to $+125^\circ\text{C}$	16 CERDIP**

Ordering Information continued at end of data sheet.

* Contact factory for dice specifications.

** Contact factory for availability and processing to MIL-STD-883B.

Pin Configurations

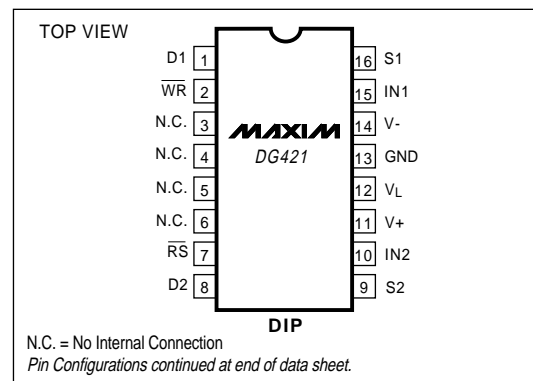

MAXIM

Maxim Integrated Products 1

Call toll free 1-800-998-8800 for free samples or literature.

DG421/DG423/DG425

Improved Low-Power, CMOS Analog Switches with Latches

ABSOLUTE MAXIMUM RATINGS

Voltage Referenced to V-	Continuous Power Dissipation (T _A = +70°C)
V+ 44V	16-Pin Plastic DIP (derate 10.53mW/°C above +70°C) ... 842mW
GND 25V	20-Pin PLCC (derate 10.00mW/°C above +70°C) 800mW
V _L (GND - 0.3V) to (V+ + 0.3V)	16-Pin CERDIP (derate 10.00mW/°C above +70°C) ... 800mW
Digital Inputs, V _S , V _D (Note 1) (V- - 2V) to (V+ + 2V)	Operating Temperature Ranges
Current (any terminal, except S or D) 30mA	DG42_C_ 0°C to +70°C
Continuous Current, S or D 20mA	DG42_D_ -40°C to +85°C
Peak Current, S or D (pulsed at 1ms, 10% duty cycle max) ... 100mA	DG42_A_ -55°C to +125°C
	Storage Temperature Ranges
	DG42_C_/DG42_D_ -65°C to +125°C
	DG42_A_ -65°C to +150°C
	Lead Temperature (soldering, 10sec) +300°C

Note 1: Signals on S, D, or IN exceeding V+ or V- are clamped by internal diodes. Limit forward current to maximum current ratings.

Stresses beyond those listed under "Absolute Maximum Ratings" may cause permanent damage to the device. These are stress ratings only, and functional operation of the device at these or any other conditions beyond those indicated in the operational sections of the specifications is not implied. Exposure to absolute maximum rating conditions for extended periods may affect device reliability.

ELECTRICAL CHARACTERISTICS

(V+ = 15V, V- = -15V, V_L = +5V, GND = 0V, V_{INH} = +2.4V, V_{INL} = +0.8V, T_A = T_{MIN} to T_{MAX}, unless otherwise noted.)

PARAMETER	SYMBOL	CONDITIONS	DG42_C, DG42_D			DG42_A			UNITS			
			MIN	TYP	MAX	MIN	TYP	MAX				
SWITCH												
Analog Signal Range	V _{ANALOG}	(Note 3)	-15		15	-15		15	V			
Drain-Source On-Resistance	r _{DS(ON)}	V+ = 13.5V, V- = -13.5V, I _S = -10mA, V _D = ±10V	T _A = +25°C			20			45	Ω		
		T _A = T _{MIN} to T _{MAX}			45			45				
On-Resistance Match Between Channels (Note 4)	Δr _{DS(ON)}	V+ = 16.5V, V- = -16.5V, I _S = -10mA, V _D = ±10V	T _A = +25°C			3			3	Ω		
		T _A = T _{MIN} to T _{MAX}			4			4				
On-Resistance Flatness (Note 4)	r _{FLAT(ON)}	V+ = 15V, V- = -15V, I _S = -10mA, V _D = ±5V	T _A = +25°C			4			4	Ω		
		T _A = T _{MIN} to T _{MAX}			5			5				
Source-Off Leakage Current (Note 5)	I _{S(OFF)}	V+ = 16.5V, V- = -16.5V, V _D = ±15.5V, V _S = ∓15.5V	T _A = +25°C			-0.50	-0.01	0.50	-0.25	-0.01	0.25	nA
		T _A = T _{MIN} to T _{MAX}			-5	5	-10	10				
Drain-Off Leakage Current (Note 5)	I _{D(OFF)}	V+ = 16.5V, V- = -16.5V, V _D = ±15.5V, V _S = ∓15.5V	T _A = +25°C			-0.50	-0.01	0.50	-0.25	-0.01	0.25	nA
		T _A = T _{MIN} to T _{MAX}			-5	5	-10	10				
Drain-On Leakage Current (Note 5)	I _{D(ON)}	V+ = 16.5V, V- = -16.5V, V _D = ±15.5V, V _S = ±15.5V	T _A = +25°C			-1.0	-0.04	1.0	-0.40	-0.04	0.40	nA
		T _A = T _{MIN} to T _{MAX}			-10	10	-20	20				

Improved Low-Power, CMOS Analog Switches with Latches

DG421/DG423/DG425

ELECTRICAL CHARACTERISTICS (continued)

(V+ = 15V, V- = -15V, VL = +5V, GND = 0V, VINH = +2.4V, VINL = +0.8V, TA = TMIN to TMAX, unless otherwise noted.)

PARAMETER	SYMBOL	CONDITIONS	MIN	TYP (Note 2)	MAX	UNITS	
INPUT							
Input Current with Input Voltage High	IINH	IN = 2.4V, all others = 0.8V	-0.50	0.005	0.50	μA	
Input Current with Input Voltage Low	IINL	IN = 0.8V, all others = 2.4V	-0.50	0.005	0.50	μA	
SUPPLY							
Power Supply Range	V+, V-	(Note 3)	±4.5		±20	V	
Positive Supply Current	I+	All channels on or off, V+ = 16.5V, V- = -16.5V, VIN = 0V or 5V	TA = +25°C	-1.0	0.01	1.0	μA
			TA = TMIN to TMAX	-5.0		5.0	
Negative Supply Current	I-	All channels on or off, V+ = 16.5V, V- = -16.5V, VIN = 0V or 5V	TA = +25°C	-1.0	-0.01	1.0	μA
			TA = TMIN to TMAX	-5.0		5.0	
Logic Supply Current	IL	All channels on or off, V+ = 16.5V, V- = -16.5V, VIN = 0V or 5V	TA = +25°C	-1.0	-0.01	1.0	μA
			TA = TMIN to TMAX	-5.0		5.0	
Ground Current	IGND	All channels on or off, V+ = 16.5V, V- = -16.5V, VIN = 0V or 5V	TA = +25°C	-1.0	-0.01	1.0	μA
			TA = TMIN to TMAX	-5.0		5.0	
DYNAMIC							
Turn-On Time	tON	Figure 2	TA = +25°C	150	250	ns	
			TA = TMIN to TMAX		300		
Turn-Off Time	tOFF	Figure 2			200	ns	
Latch Timing	tWW	VS = ±10V, RL = 300Ω, CL = 35pF, Figure 3	TA = +25°C	200		ns	
			TA = -55°C to +125°C	200			
	TA = +25°C		100				
	TA = -55°C to +125°C		100				
	TA = +25°C		60				
	tDW		TA = +25°C	60			
	tWD		TA = -55°C to +125°C	100			
Break-Before-Make Interval (Note 3)	tD	DG423, Figure 4	TA = +25°C	5	25	ns	
Charge Injection (Note 3)	Q	CL = 10nF, VG = 0V, RG = 0Ω, Figure 5	TA = +25°C	10	15	pC	
Off-Isolation Rejection Ratio (Note 6)	OIRR	RL = 100Ω, CL = 5pF, f = 1MHz, Figure 6	TA = +25°C	72		dB	
Crosstalk (Note 7)		RL = 50Ω, CL = 5pF, f = 1MHz, Figure 7	TA = +25°C	90		dB	
Drain-Off Capacitance	CD(OFF)	f = 1MHz, Figure 8	TA = +25°C	12		pF	
Source-Off Capacitance	CS(OFF)	f = 1MHz, Figure 8	TA = +25°C	12		pF	
Drain-On Capacitance	CD(ON)	f = 1MHz, Figure 9	TA = +25°C	39		pF	
Source-On Capacitance	CS(ON)	f = 1MHz, Figure 9	TA = +25°C	39		pF	

Note 2: Typical values are for design aid only, are not guaranteed, and are not subject to production testing. The algebraic convention, where the most negative value is a minimum and the most positive value a maximum, is used in this data sheet.

Note 3: Guaranteed by design.

Note 4: On-resistance match between channels and flatness are guaranteed only with bipolar-supply operation. Flatness is defined as the difference between the maximum and minimum value of on-resistance as measured at the extremes of the specified analog signal range.

Note 5: Leakage parameters IS(OFF), ID(OFF), and ID(ON) are 100% tested at the maximum rated hot temperature and guaranteed by correlation at +25°C.

Note 6: Off-Isolation Rejection Ratio = 20log (VD/VS), VD = output, VS = input to off switch.

Note 7: Between any two switches.

MAXIM

Improved Low-Power, CMOS Analog Switches with Latches

Typical Operating Characteristics

($T_A = +25^\circ\text{C}$, unless otherwise noted.)

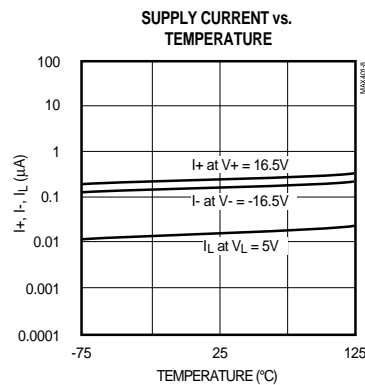
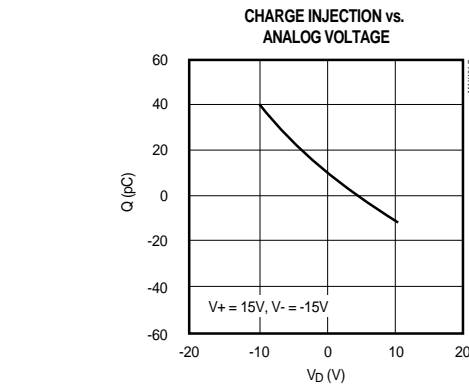
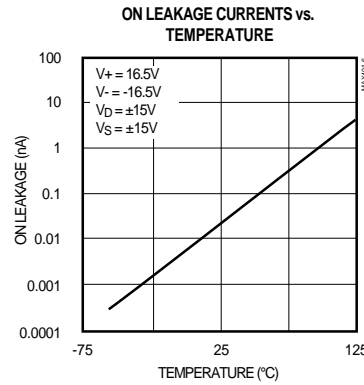
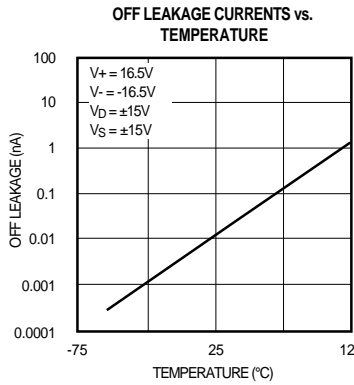
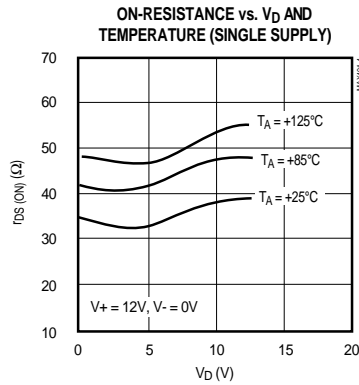
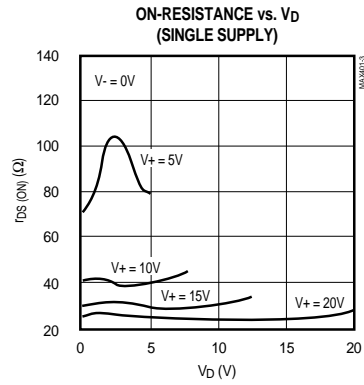
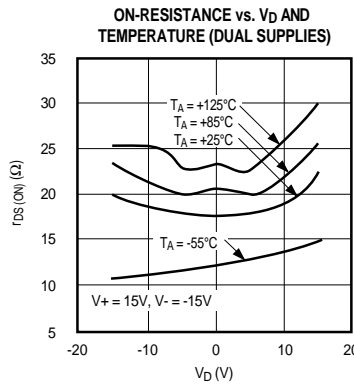
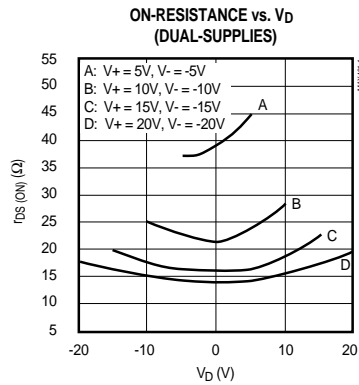

Improved Low-Power, CMOS Analog Switches with Latches

DG421/DG423/DG425

Pin Descriptions

DG421			
PIN	NAME	FUNCTION	
1, 8	D1, D2	Drain Terminals	
2	\overline{WR}	Write Select	
3, 4, 5, 6	N.C.	No Internal Connection	
7	\overline{RS}	Reset Select	
9, 16	S1, S2	Source Terminals	
10, 15	IN1, IN2	Input Control	
11	V+	Positive Supply	
12	V _L	Logic Supply	
13	GND	Ground	
14	V-	Negative Supply	
DG423/DG425			
DIP	PLCC	NAME	FUNCTION
1, 8, 3, 6	2, 10, 4, 8	D1-D4	Drain Terminals
2	3	\overline{WR}	Write Select
16, 9, 4, 5	20, 12, 5, 7	S1-S4	Source Terminals
7	9	\overline{RS}	Resets Select
15, 10	19, 13	IN1, IN2	Input Control
11	14	V+	Positive Supply
12	15	V _L	Logic Supply
—	1, 6, 11, 16	N.C.	No Internal Connection
14	18	V-	Negative Supply
13	17	GND	Ground

Applications Information

Operation with Supply Voltages Other Than $\pm 15V$

The DG421/DG423/DG425 switches operate with $\pm 4.5V$ to $\pm 20V$ bipolar supplies or with a $+10V$ to $+30V$ single supply. In either case, analog signals ranging from $V+$ to $V-$ can be switched. The *Typical Operating Characteristics* graphs illustrate typical analog-signal and supply-voltage on-resistance variations. The usual on-resistance temperature coefficient is $0.5\%/^{\circ}C$ (typ).

Logic Inputs

These devices operate with a single positive supply or with bipolar supplies. They maintain TTL compatibility with supplies anywhere in the $\pm 4.5V$ to $\pm 20V$ range as long as $V_L = +5V$. If V_L is connected to $V+$ or another supply at voltages other than $+5V$, the devices will operate at CMOS-logic-level inputs.

Overvoltage Protection

Proper power-supply sequencing is recommended for all CMOS devices. Do not exceed the absolute maximum ratings because stresses beyond the listed ratings may cause permanent damage to the devices. Always sequence $V+$ on first, followed by V_L , $V-$, and logic inputs. If power-supply sequencing is not possible, add two small, external signal diodes in series with supply pins for overvoltage protection (Figure 1). Adding diodes reduces the analog signal range to $1V$ below $V+$ and $1V$ above $V-$, without affecting low switch resistance and low leakage characteristics. Device operation is unchanged, and the difference between $V+$ and $V-$ should not exceed $+44V$.

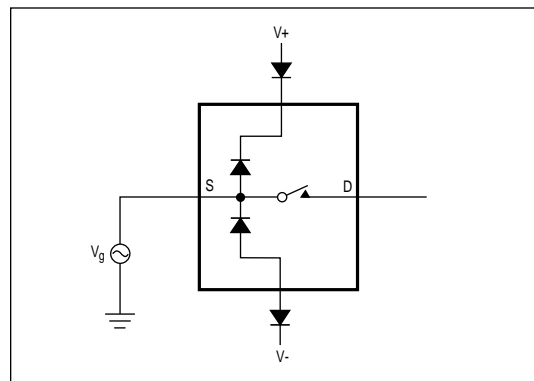

Figure 1. Overvoltage Protection Using External Blocking Diodes

Improved Low-Power, CMOS Analog Switches with Latches

Timing Diagrams/Test Circuits

V_{OUT} is the steady-state output with the switch on. Feedthrough via switch capacitance may result in spikes at the leading and trailing edge of the output waveform.

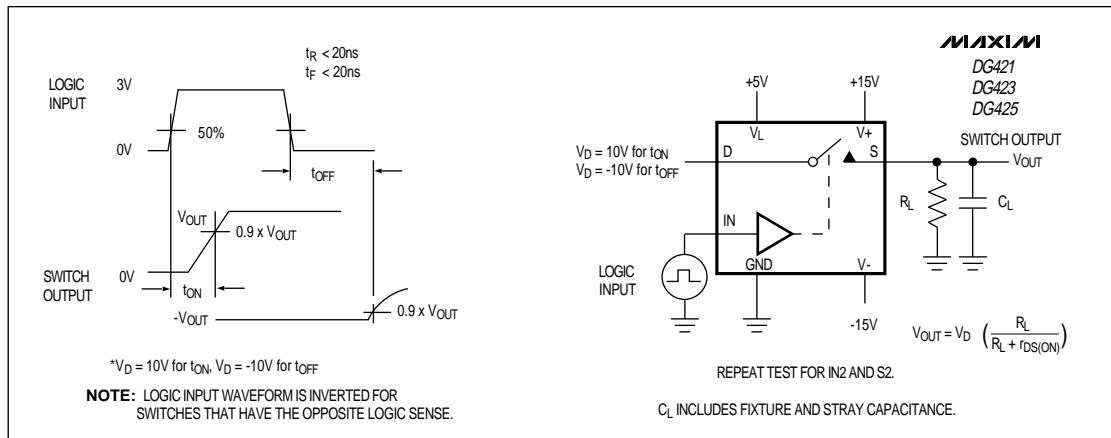

Figure 2. Switching Time

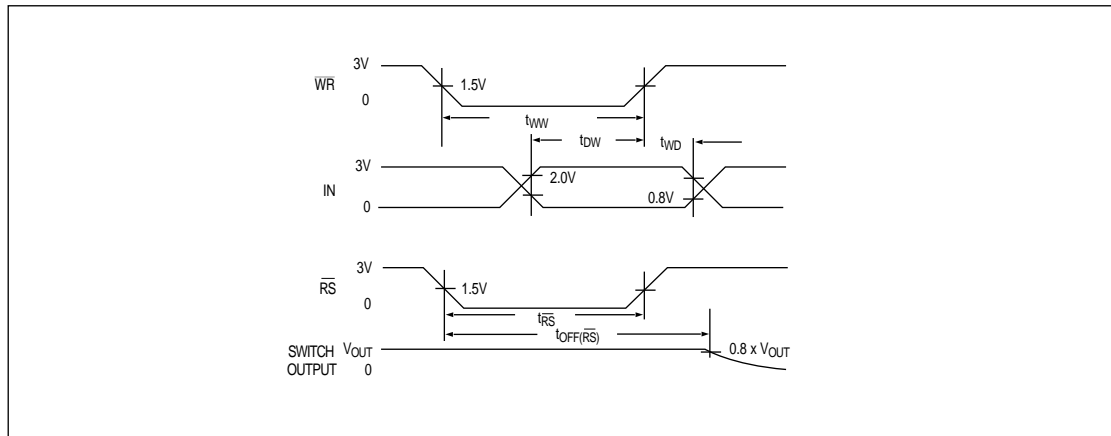

Figure 3. Latch Timing

Improved Low-Power, CMOS Analog Switches with Latches

Timing Diagrams/Test Circuits (continued)

DG421/DG423/DG425

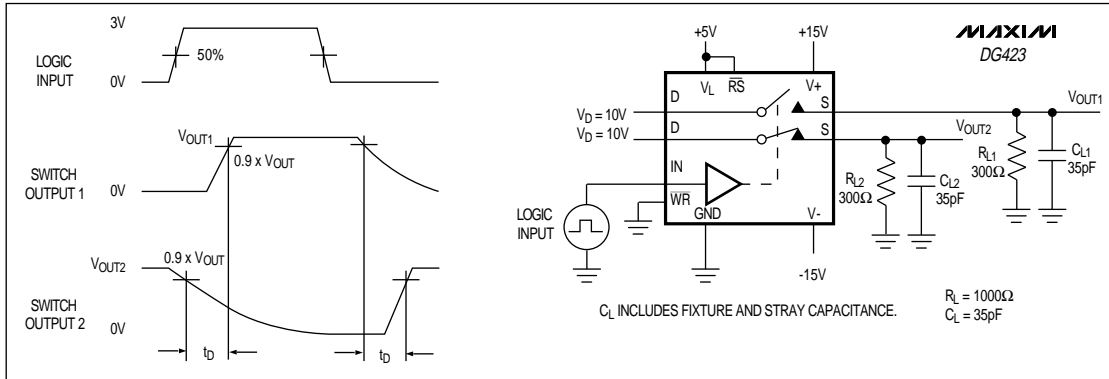

Figure 4. DG423 Break-Before-Make Interval

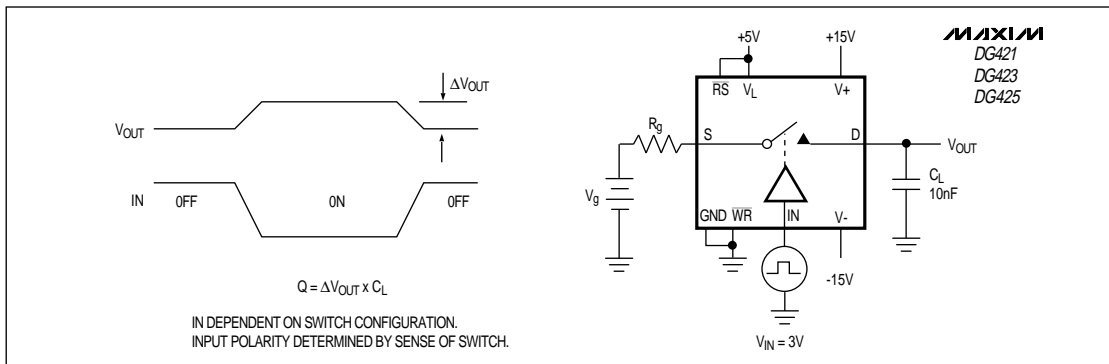

Figure 5. Charge Injection

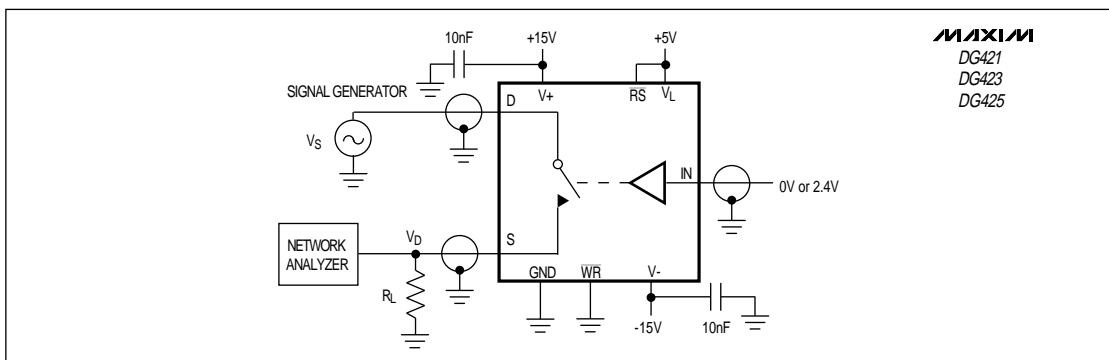

Figure 6. Off-Isolation Rejection Ratio

MAXIM

Improved Low-Power, CMOS Analog Switches with Latches

Timing Diagrams/Test Circuits (continued)

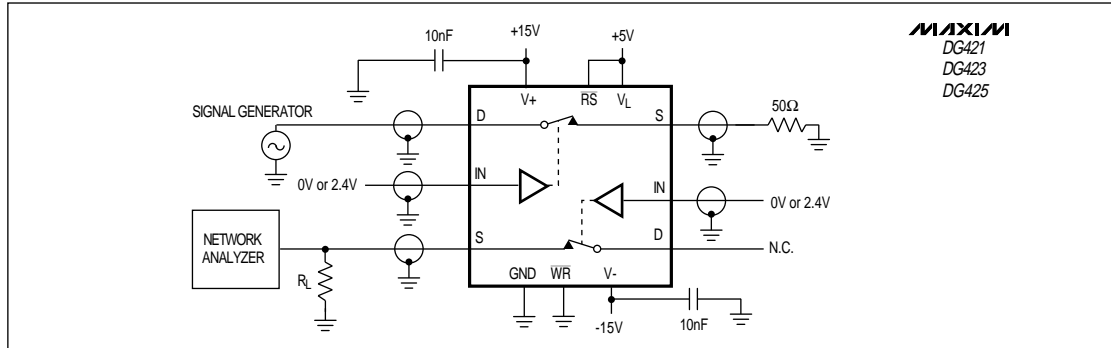

Figure 7. Crosstalk

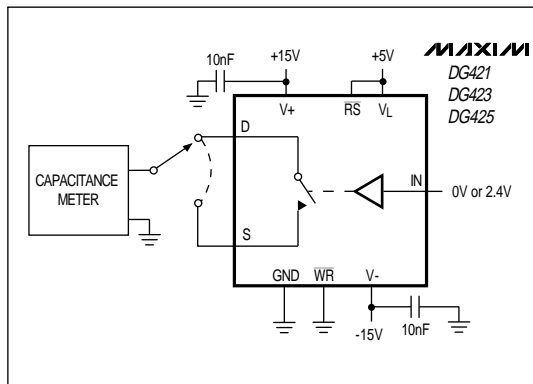

Figure 8. Drain/Source-Off Capacitance

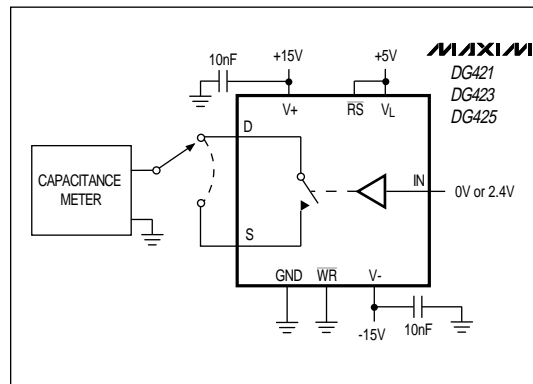
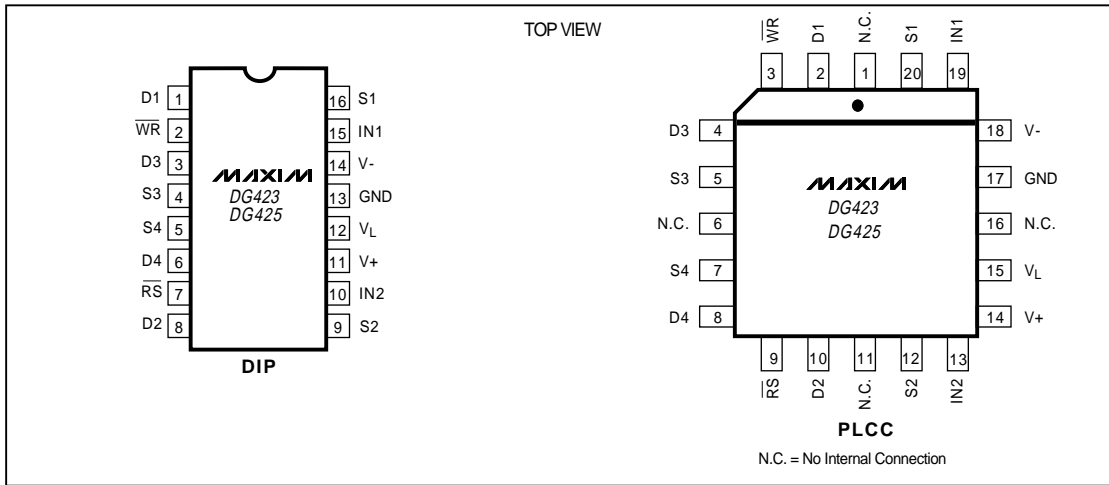

Figure 9. Drain/Source-On Capacitance

Improved Low-Power, CMOS Analog Switches with Latches

Pin Configurations (continued)

DG421/DG423/DG425



Functional Diagrams/Truth Tables (continued)

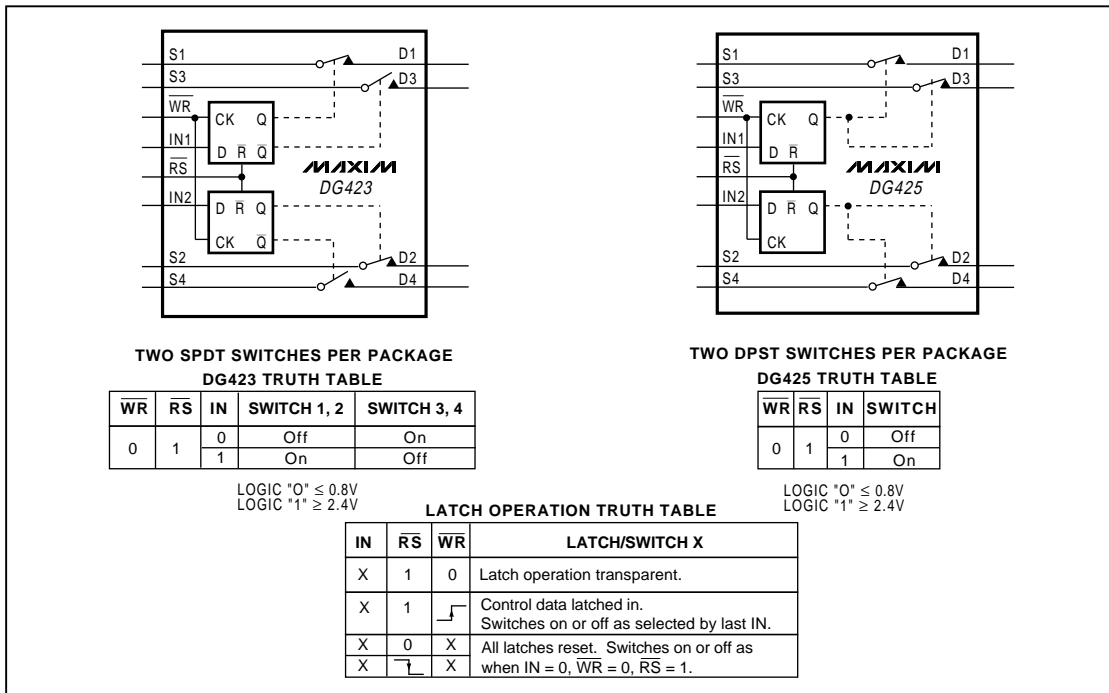

Improved Low-Power, CMOS Analog Switches with Latches

Ordering Information (continued)

PART	TEMP. RANGE	PIN-PACKAGE
DG423CJ	0°C to +70°C	16 Plastic DIP
DG423CY	0°C to +70°C	16 SO
DG423C/D	0°C to +70°C	Dice*
DG423DJ	-40°C to +85°C	16 Plastic DIP
DG423DY	-40°C to +85°C	16 SO
DG423DN	-40°C to +85°C	20 PLCC
DG423DK	-40°C to +85°C	16 CERDIP
DG423AK	-55°C to +125°C	16 CERDIP**
DG425CJ	0°C to +70°C	16 Plastic DIP
DG425CY	0°C to +70°C	16 SO
DG425C/D	0°C to +70°C	Dice*
DG425DJ	-40°C to +85°C	16 Plastic DIP
DG425DY	-40°C to +85°C	16 SO
DG425DN	-40°C to +85°C	20 PLCC
DG425DK	-40°C to +85°C	16 CERDIP
DG425AK	-55°C to +125°C	16 CERDIP**

* Contact factory for dice specifications.

**Contact factory for availability and processing to MIL-STD-883B.

Chip Topographies

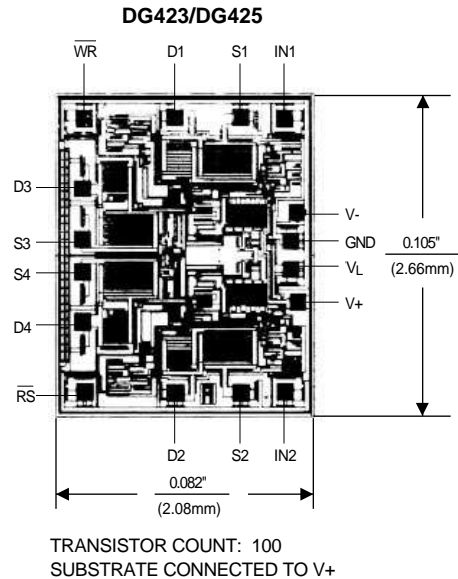
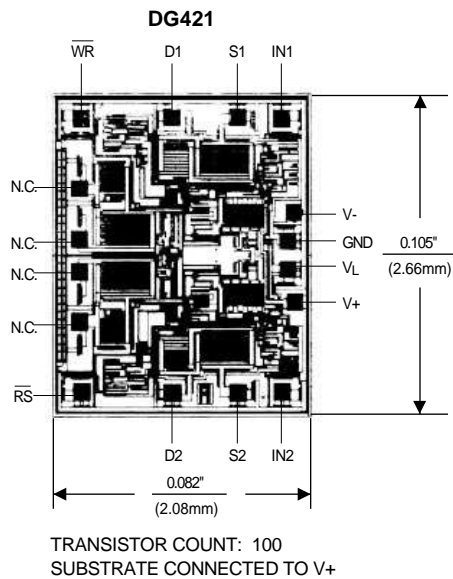

Improved Low-Power, CMOS Analog Switches with Latches

Package Information

DG421/DG423/DG425

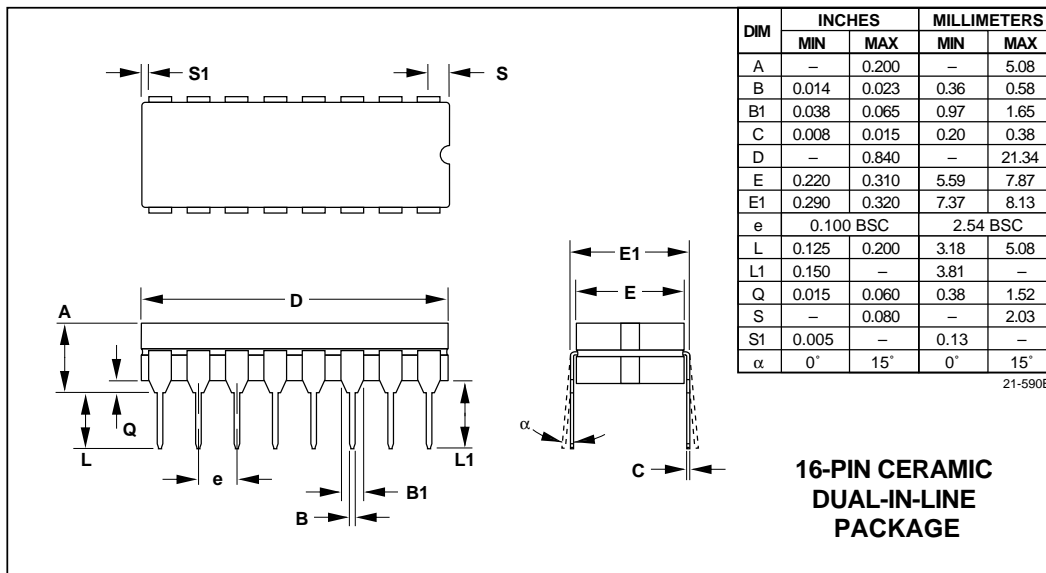
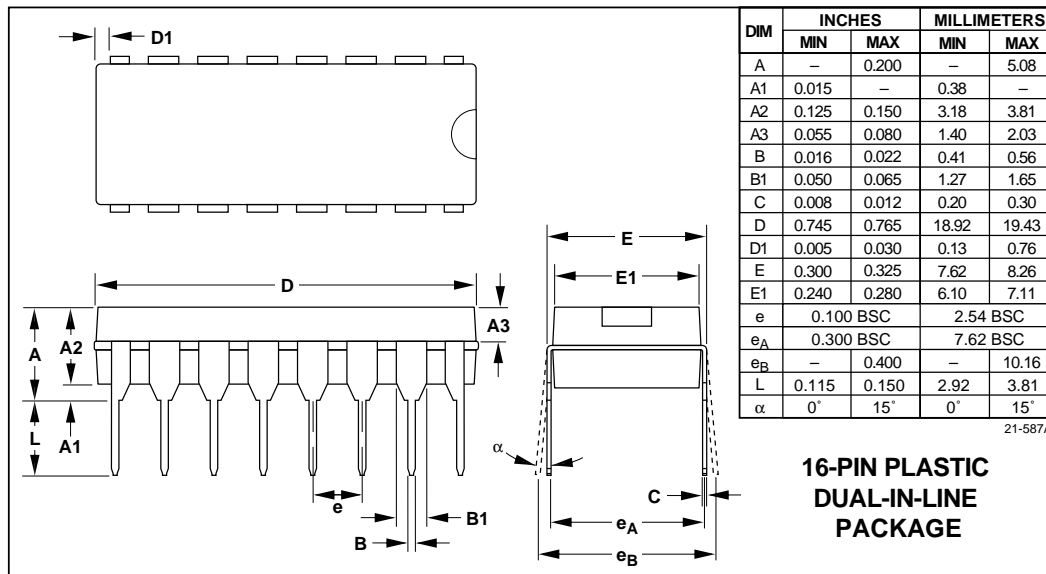

Improved Low-Power, CMOS Analog Switches with Latches

Package Information (continued)

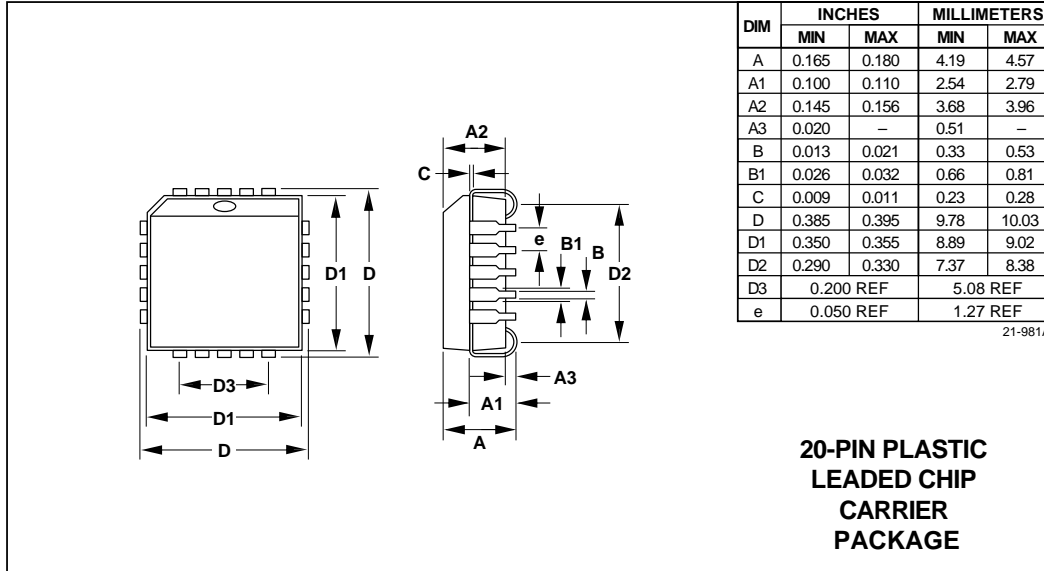

Maxim cannot assume responsibility for use of any circuitry other than circuitry entirely embodied in a Maxim product. No circuit patent licenses are implied. Maxim reserves the right to change the circuitry and specifications without notice at any time.

12 _____ Maxim Integrated Products, 120 San Gabriel Drive, Sunnyvale, CA 94086 (408) 737-7600

© 1994 Maxim Integrated Products

Printed USA

MAXIM is a registered trademark of Maxim Integrated Products.