



# High Voltage 4-Ω Quad SPST CMOS Analog Switch

## DESCRIPTION

The DG454 series has four independently selectable high voltage (44 V) SPST switches, each with a typical on resistance of 4 Ω and a typical flatness of 0.2 Ω, ideal parameters for low distortion audio signal switching.

The DG454 (NC) and DG455 (NO) are identical except for the digital logic control input, which is inverted as shown in the Truth Table. The DG456 has two normally closed and two normally open switches.

These are high voltage switches that are fully specified with dual supplies at ± 5 V and ± 15 V and a single supply of 12 V.

Fast switching speeds coupled with high signal bandwidth makes these parts suitable for video switching applications.

All digital inputs have 0.8 V and 2.4 V logic thresholds ensuring low voltage TTL/CMOS compatibility. Each switch conducts equally well in both directions when on and can handle an input signal range that extends to the supply voltage rails.

The DG454 DG455 and DG456 are pin compatible with the DG411, DG412 and DG413, except they require no  $V_L$  supply.

## FEATURES

- Low on-resistance (4 Ω typical)
- On-resistance flatness (0.2 Ω typical)
- 44 V supply maximum rating
- ± 15 V analog signal range
- Fully specified at supply voltages of ± 5 V, 12 V and ± 15 V
- No  $V_L$  required
- Fast switching speed:
  - $t_{on}$  80 ns
  - $t_{off}$  60 ns
- TTL/CMOS compatible
- ESD protection 2 kV
- Pin compatible with DG411, DG412, and DG413, except no  $V_L$  required



RoHS COMPLIANT

## APPLICATIONS

- Audio and video signal switching
- Precision automatic test equipment
- Precision data acquisition
- Relay replacement
- Communications systems
- Automotive and avionics applications
- Sample and hold systems

## FUNCTIONAL BLOCK DIAGRAM AND PIN CONFIGURATION

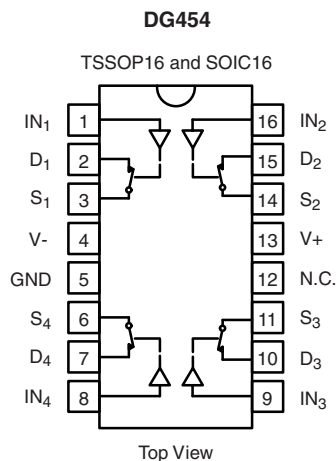

TRUTH TABLE		
Logic	DG454	DG455
0	ON	OFF
1	OFF	ON

TRUTH TABLE		
Logic	SW <sub>1</sub> , SW <sub>4</sub>	SW <sub>2</sub> , SW <sub>3</sub>
0	OFF	ON
1	ON	OFF

ORDERING INFORMATION		
Temp Range	Package	Part Number
DG454/DG455/DG456		
- 40 °C to 125 °C <sup>a</sup>	16-Pin TSSOP	DG454EQ-T1-E3 DG455EQ-T1-E3 DG456EQ-T1-E3
	16-Pin Narrow SOIC	DG454EY-T1-E3 DG455EY-T1-E3 DG456EY-T1-E3

Notes:

a. - 40 °C to 85 °C datasheet limits apply.

ABSOLUTE MAXIMUM RATINGS $T_A = 25\text{ °C}$ , unless otherwise noted			
Parameter		Limit	Unit
V+ to V-		44	V
GND to V-		25	
Digital Inputs <sup>a</sup> , $V_S$ , $V_D$		(V-) - 2 to (V+) + 2 or 30 mA, whichever occurs first	
Continuous Current (Any Terminal)		30	mA
Peak Current, S or D (Pulsed 1 ms, 10 % Duty Cycle)		100	
Storage Temperature		- 65 to 150	°C
Power Dissipation (Package) <sup>b</sup>	16-Pin TSSOP <sup>c</sup>	450	mW
	16-Pin Narrow SOIC <sup>d</sup>	600	
Thermal Resistance (Package) <sup>b</sup>	16-Pin TSSOP	178	°C/W
	16-Pin Narrow SOIC	125	
ESD (HBM)		2	kV

Notes:

a. Signals on  $S_X$ ,  $D_X$ , or  $IN_X$  exceeding V+ or V- will be clamped by internal diodes. Limit forward diode current to maximum current ratings.

b. All leads welded or soldered to PC board.

c. Derate 5.6 mW/°C above 70 °C.

d. Derate 8.0 mW/°C above 75 °C.

SPECIFICATIONS FOR DUAL SUPPLIES									
Parameter	Symbol	Test Conditions Unless Specified $V_+ = 15\text{ V}$ , $V_- = -15\text{ V}$ $V_{IN} = 2.4\text{ V}$ , $0.8\text{ V}^a$	Temp. <sup>b</sup>	Typ. <sup>c</sup>	- 40 to 125 °C		- 40 to 85 °C		Unit
					Min. <sup>d</sup>	Max. <sup>d</sup>	Min. <sup>d</sup>	Max. <sup>d</sup>	
<b>Analog Switch</b>									
Analog Signal Range <sup>e</sup>	$V_{ANALOG}$		Full		- 15	15	- 15	15	V
On-Resistance	$r_{ON}$	$I_S = -10\text{ mA}$ , $V_D = -10\text{ V to } +10\text{ V}$	Room Full	3.8		5.3 8.3		5.3 7.3	Ω
On-Resistance Match	$\Delta r_{ON}$	$I_S = -10\text{ mA}$ , $V_D = \pm 10\text{ V}$	Room Full	0.12		0.5 1		0.5 0.5	
On-Resistance Flatness	$r_{FLATNESS}$	$I_S = -10\text{ mA}$ , $V_D = -5\text{ V}, 0\text{ V}, +5\text{ V}$	Room Full	0.25		0.5 0.5		0.5 0.5	
Switch Off Leakage Current	$I_{S(off)}$	$V_D = \pm 10\text{ V}$ , $V_S = \mp 10\text{ V}$	Room Full	$\pm 0.1$	- 0.5 - 20	0.5 20	- 0.5 - 2.5	0.5 2.5	nA
	$I_{D(off)}$		Room Full	$\pm 0.1$	- 0.5 - 20	0.5 20	- 0.5 - 2.5	0.5 2.5	
Channel On Leakage Current	$I_{D(on)}$	$V_S = V_D = \pm 10\text{ V}$	Room Full	$\pm 0.1$	- 1 - 40	1 40	- 1 - 5	1 5	



SPECIFICATIONS FOR DUAL SUPPLIES									
Parameter	Symbol	Test Conditions Unless Specified $V_+ = 15\text{ V}$ , $V_- = -15\text{ V}$ $V_{IN} = 2.4\text{ V}$ , $0.8\text{ V}^a$	Temp. <sup>b</sup>	Typ. <sup>c</sup>	- 40 to 125 °C		- 40 to 85 °C		Unit
					Min. <sup>d</sup>	Max. <sup>d</sup>	Min. <sup>d</sup>	Max. <sup>d</sup>	
<b>Digital Control</b>									
Input Current, $V_{IN}$ Low	$I_{IL}$	$V_{IN}$ Under Test = 0.8 V	Full	0.005	- 0.5	0.5	- 0.5	0.5	$\mu\text{A}$
Input Current, $V_{IN}$ High	$I_{IH}$	$V_{IN}$ Under Test = 2.4 V	Full	0.005	- 0.5	0.5	- 0.5	0.5	
Input Capacitance <sup>e</sup>	$C_{IN}$	$f = 1\text{ MHz}$	Room	7					$\text{pF}$
<b>Dynamic Characteristics</b>									
Turn-On Time	$t_{ON}$	$R_L = 300\ \Omega$ , $C_L = 35\text{ pF}$ $V_S = \pm 10\text{ V}$ , See Figure 2	Room	88		118		118	ns
Turn-Off Time	$t_{OFF}$		Full	69		97		97	
Break-Before-Make Time Delay	$t_D$	DG456 only, $V_S = 10\text{ V}$ $R_L = 300\ \Omega$ , $C_L = 35\text{ pF}$	Room	18					
Charge Injection <sup>e</sup>	Q	$V_g = 0\text{ V}$ , $R_g = 0\ \Omega$ , $C_L = 1\text{ nF}$	Room	22					$\text{pC}$
Off Isolation <sup>e</sup>	OIRR	$R_L = 50\ \Omega$ , $C_L = 5\text{ pF}$ $f = 1\text{ MHz}$	Room	- 60					dB
Channel-to-Channel Crosstalk <sup>e</sup>	$X_{TALK}$		Room	- 85					
Source Off Capacitance <sup>e</sup>	$C_{S(off)}$	$f = 1\text{ MHz}$	Room	31					$\text{pF}$
Drain Off Capacitance <sup>e</sup>	$C_{D(off)}$		Room	34					
Channel On Capacitance <sup>e</sup>	$C_{D(on)}$		Room	103					
Total Harmonic Distortion <sup>e</sup>	THD	Signal = 5 $V_{RMS}$ , 20 Hz to 20 kHz, $R_L = 600\ \Omega$	Room	0.04					%
<b>Power Supplies</b>									
Power Supply Current	$I_+$	$V_+ = 16.5\text{ V}$ , $V_- = -16.5\text{ V}$ $V_{IN} = 0$ or $5\text{ V}$	Room	25		100		100	$\mu\text{A}$
Negative Supply Current	$I_-$		Full	- 0.001	- 0.5		- 0.5		
Ground Current	$I_{GND}$		Full	- 25	- 100		- 100		

SPECIFICATIONS FOR DUAL SUPPLIES									
Parameter	Symbol	Test Conditions Unless Specified $V_+ = 5\text{ V}$ , $V_- = -5\text{ V}$ $V_{IN} = 2.4\text{ V}$ , $0.8\text{ V}^a$	Temp. <sup>b</sup>	Typ. <sup>c</sup>	- 40 to 125 °C		- 40 to 85 °C		Unit
					Min. <sup>d</sup>	Max. <sup>d</sup>	Min. <sup>d</sup>	Max. <sup>d</sup>	
<b>Analog Switch</b>									
Analog Signal Range <sup>e</sup>	$V_{ANALOG}$		Full		- 5	5	- 5	5	V
On-Resistance	$r_{ON}$	$V_+ = +5\text{ V}$ , $V_- = -5\text{ V}$ $I_S = -10\text{ mA}$ , $V_D = -3.5\text{ V}$ to $+3.5\text{ V}$	Room	3.8		11		11	$\Omega$
On-Resistance Match	$\Delta r_{ON}$	$V_+ = +5\text{ V}$ , $V_- = -5\text{ V}$ , $I_S = -10\text{ mA}$ , $V_D = \pm 3.5\text{ V}$	Full	0.13		0.5		0.5	
<b>Dynamic Characteristics</b>									
Turn-On Time <sup>e</sup>	$t_{ON}$	$R_L = 300\ \Omega$ , $C_L = 35\text{ pF}$ $V_S = 3\text{ V}$ , See Figure 2	Room	170		200		200	ns
Turn-Off Time <sup>e</sup>	$t_{OFF}$		Full	66		96		96	
Break-Before-Make <sup>e</sup> Time Delay	$t_D$	DG456 only, $V_S = 3\text{ V}$ $R_L = 300\ \Omega$ , $C_L = 35\text{ pF}$	Room	98					
Charge Injection <sup>e</sup>	Q	$V_g = 0\text{ V}$ , $R_g = 0\ \Omega$ , $C_L = 1\text{ nF}$	Room	8					$\text{pC}$

**SPECIFICATIONS FOR DUAL SUPPLIES**

Parameter	Symbol	Test Conditions Unless Specified $V_+ = 5\text{ V}$ , $V_- = -5\text{ V}$ $V_{IN} = 2.4\text{ V}$ , $0.8\text{ V}^a$	Temp. <sup>b</sup>	Typ. <sup>c</sup>	- 40 to 125 °C		- 40 to 85 °C		Unit
					Min. <sup>d</sup>	Max. <sup>d</sup>	Min. <sup>d</sup>	Max. <sup>d</sup>	
<b>Power Supplies</b>									
Power Supply Current	I+	$V_{IN} = 0\text{ or }5\text{ V}$	Room Full	14		100 100		100 100	$\mu\text{A}$
Negative Supply Current	I-		Room Full	- 0.001	- 0.5 - 5		- 0.5 - 5		
Ground Current	I <sub>GND</sub>		Room Full	- 14	- 100 - 100		- 100 - 100		

**SPECIFICATIONS FOR UNIPOLAR SUPPLIES**

Parameter	Symbol	Test Conditions Unless Specified $V_+ = 12\text{ V}$ , $V_- = 0\text{ V}$ $V_{IN} = 2.4\text{ V}$ , $0.8\text{ V}^a$	Temp. <sup>b</sup>	Typ. <sup>c</sup>	- 40 to 125 °C		- 40 to 85 °C		Unit
					Min. <sup>d</sup>	Max. <sup>d</sup>	Min. <sup>d</sup>	Max. <sup>d</sup>	
<b>Analog Switch</b>									
Analog Signal Range <sup>e</sup>	V <sub>ANALOG</sub>		Full			12		12	V
On-Resistance	r <sub>ON</sub>	I <sub>S</sub> = - 10 mA, V <sub>D</sub> = 0 V to + 10 V	Room Full	5.5		8.1 12.4		8.1 10.4	$\Omega$
On-Resistance Match	$\Delta r_{ON}$	I <sub>S</sub> = - 10 mA, V <sub>D</sub> = + 10 V	Room Full	0.14		0.5 1		0.5 0.5	
On-Resistance Flatness	r <sub>FLATNESS</sub>	I <sub>S</sub> = - 10 mA, V <sub>D</sub> = 0 V, + 5 V, + 10 V	Room Full	0.94		1.5 1.7		1.5 1.5	
<b>Dynamic Characteristics</b>									
Turn-On Time	t <sub>ON</sub>	R <sub>L</sub> = 300 $\Omega$ , C <sub>L</sub> = 35 pF V <sub>S</sub> = 8 V, See Figure 2	Room Full	132		162 238		162 210	ns
Turn-Off Time	t <sub>OFF</sub>		Room Full	61		91 117		91 105	
Break-Before-Make Time Delay	t <sub>D</sub>	DG456 only, V <sub>S</sub> = 8 V R <sub>L</sub> = 300 $\Omega$ , C <sub>L</sub> = 35 pF	Room	70					
Charge Injection <sup>e</sup>	Q	V <sub>g</sub> = 0 V, R <sub>g</sub> = 0 $\Omega$ , C <sub>L</sub> = 1 nF	Room	1					pC
<b>Power Supplies</b>									
Power Supply Current	I+	$V_+ = 13.5\text{ V}$ , $V_- = 0\text{ V}$ $V_{IN} = 0\text{ or }5\text{ V}$	Room Full	25		100 100		100 100	$\mu\text{A}$
Negative Supply Current	I-		Room Full	- 0.001	- 0.5 - 5		- 0.5 - 5		
Ground Current	I <sub>GND</sub>		Room Full	- 25	- 100 - 100		- 100 - 100		

## Notes:

- $V_{IN}$  = input voltage to perform proper function.
- Room = 25 °C, Full = as determined by the operating temperature suffix.
- Typical values are for DESIGN AID ONLY, not guaranteed nor subject to production testing.
- The algebraic convention whereby the most negative value is a minimum and the most positive a maximum, is used in this data sheet.
- Guaranteed by design, not subject to production test.

Stresses beyond those listed under "Absolute Maximum Ratings" may cause permanent damage to the device. These are stress ratings only, and functional operation of the device at these or any other conditions beyond those indicated in the operational sections of the specifications is not implied. Exposure to absolute maximum rating conditions for extended periods may affect device reliability.

**TYPICAL CHARACTERISTICS** 25 °C, unless otherwise noted

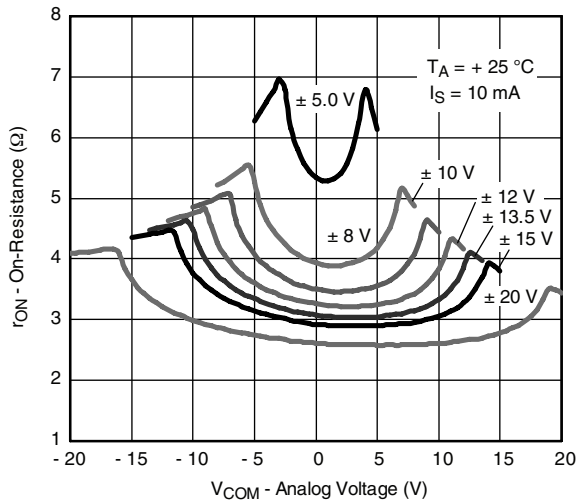

**On-Resistance vs.  $V_D$  and Dual Supply Voltage**

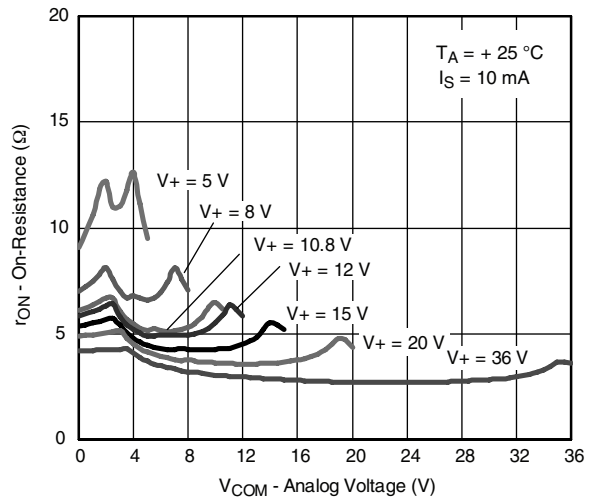

**On-Resistance vs.  $V_D$  and Single Supply Voltage**

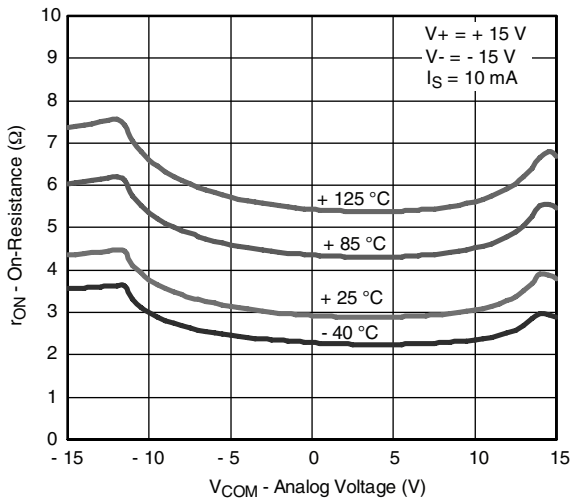

**On-Resistance vs.  $V_D$  and Temperature**

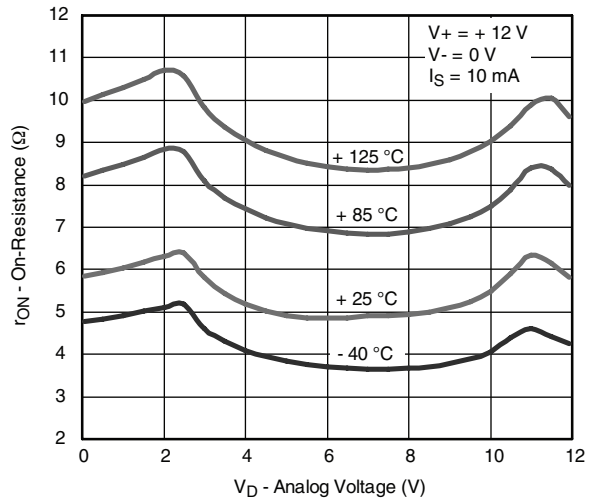

**On-Resistance vs.  $V_D$  and Temperature**

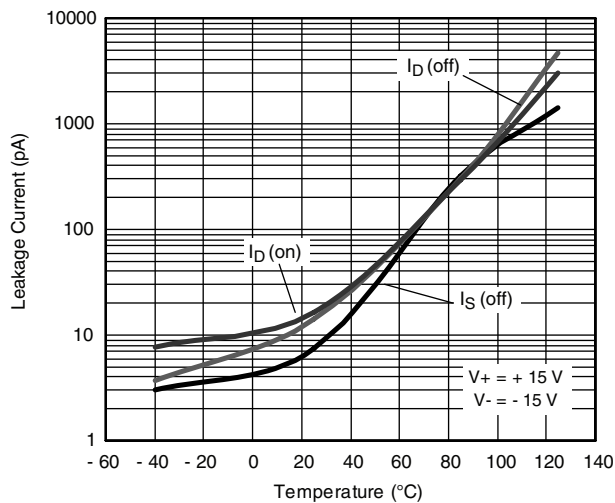

**Leakage Current vs. Temperature**

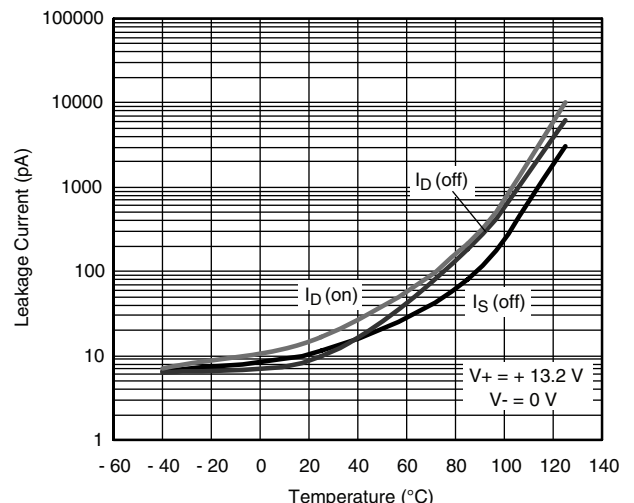

**Leakage Current vs. Temperature**



**TYPICAL CHARACTERISTICS** 25 °C, unless otherwise noted

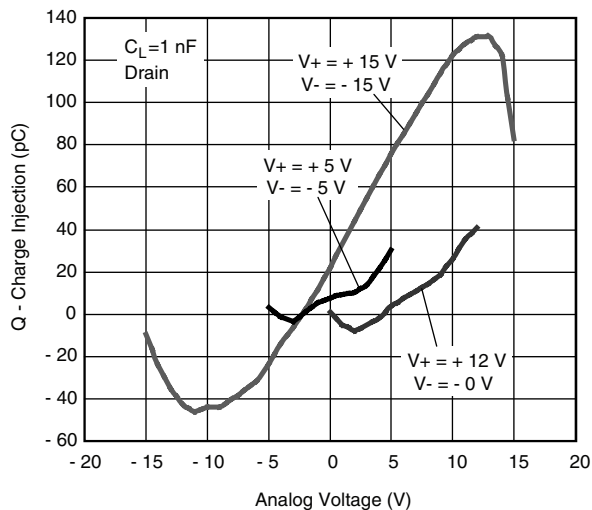

**Charge Injection vs. Analog Voltage**

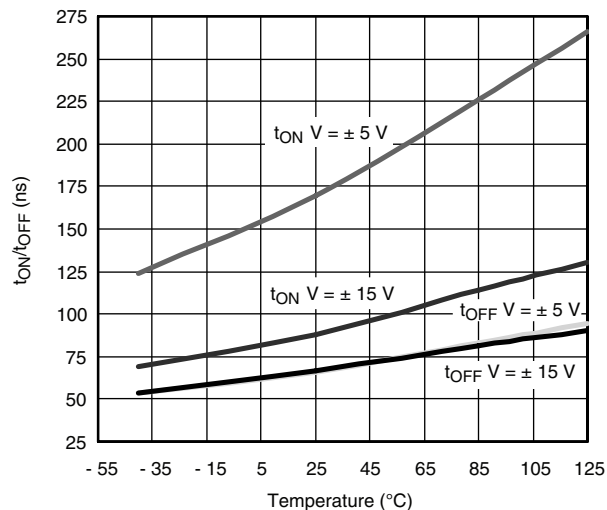

**Switching Time vs. Temperature and Dual Supply Voltage**

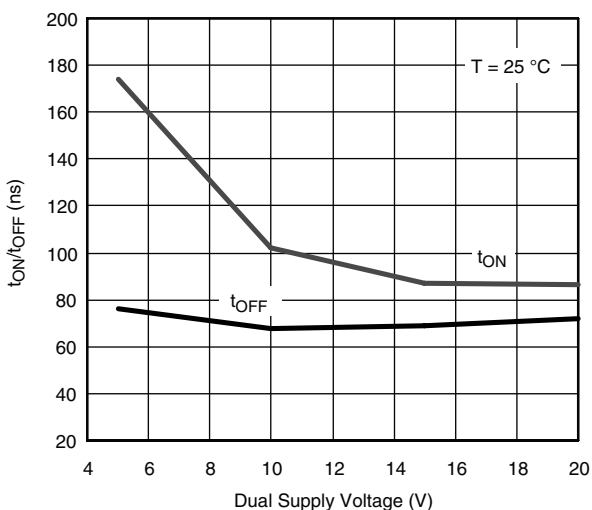

**Switching Time vs. Dual Supply Voltage**

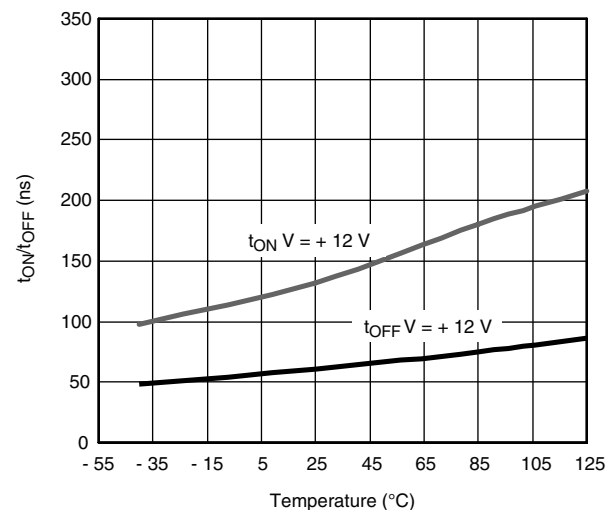

**Switching Time vs. Temperature and Single Supply Voltage**

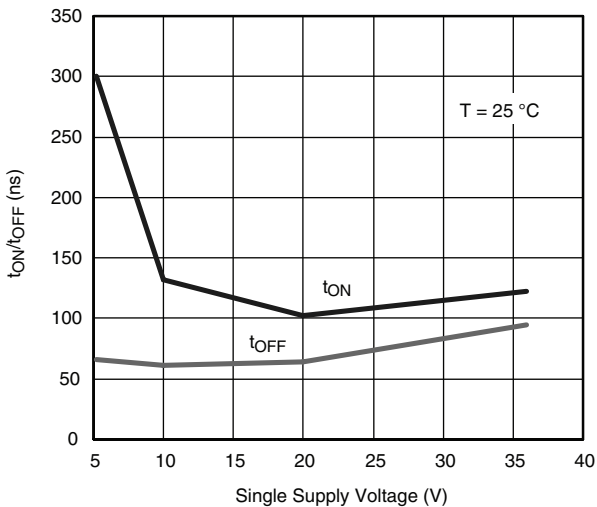

**Switching Time vs. Single Supply Voltage**

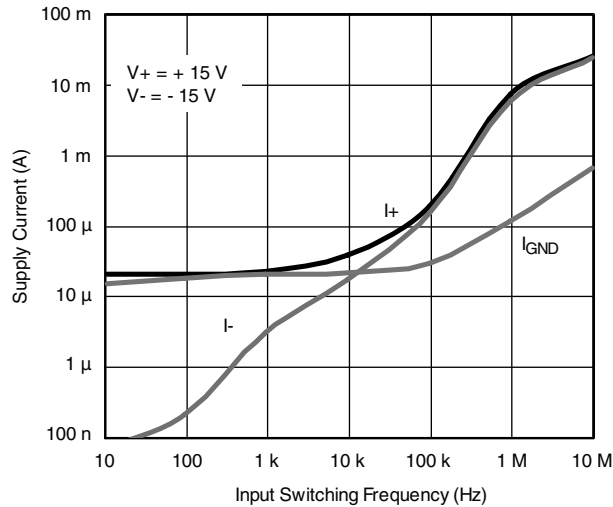

**Supply Current vs. Input Switching Frequency**

**TYPICAL CHARACTERISTICS** 25 °C, unless otherwise noted

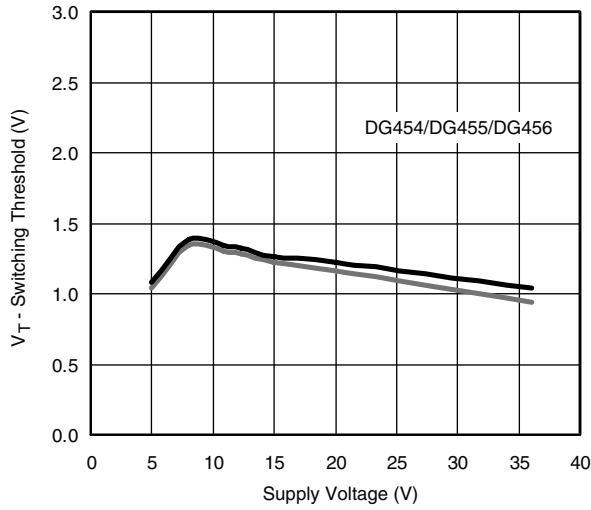

Switching Threshold vs. Supply Voltage

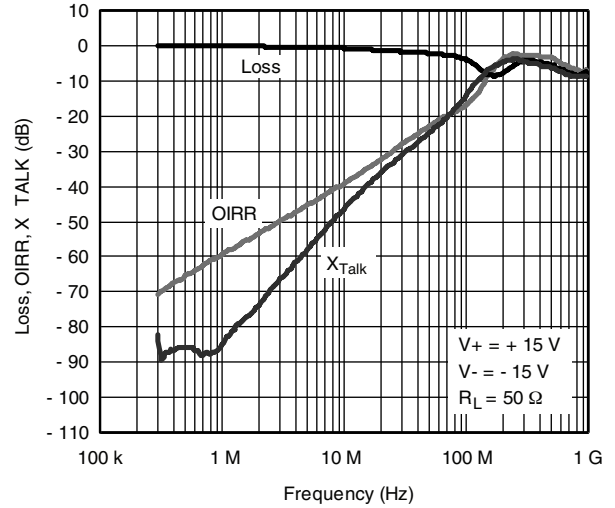

Insertion Loss, Off-Isolation, Crosstalk vs. Frequency

**TEST CIRCUITS**

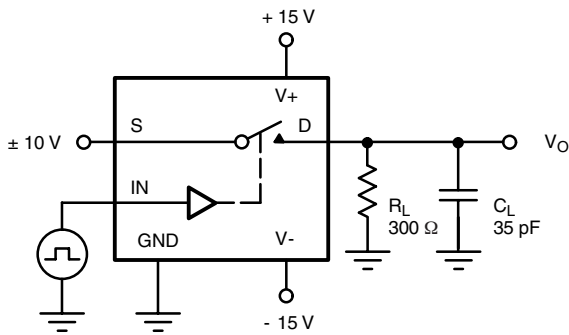

$C_L$  (includes fixture and stray capacitance)

$$V_O = V_S \frac{R_L}{R_L + r_{DS(on)}}$$

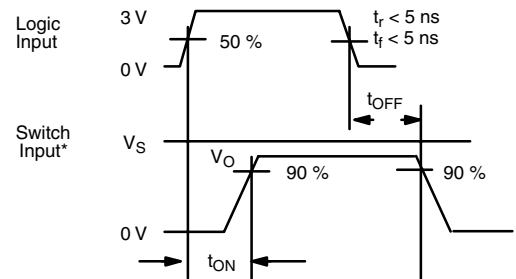

Note: Logic input waveform is inverted for switches that have the opposite logic sense control

Figure 1. Switching Time

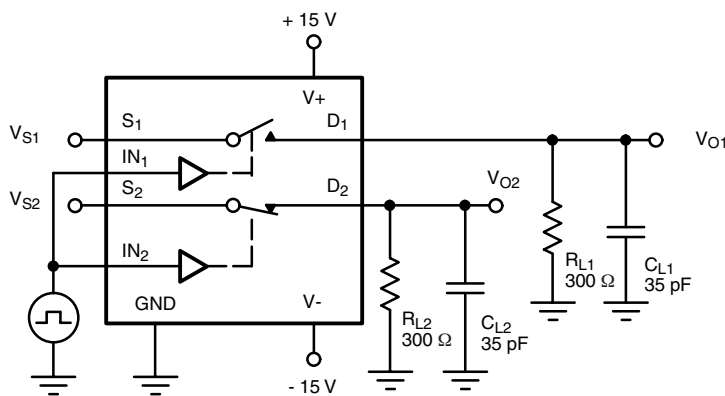

$C_L$  (includes fixture and stray capacitance)

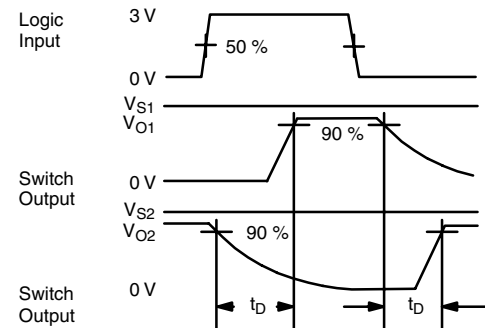

Figure 2. Break-Before-Make (DG456)

TEST CIRCUITS

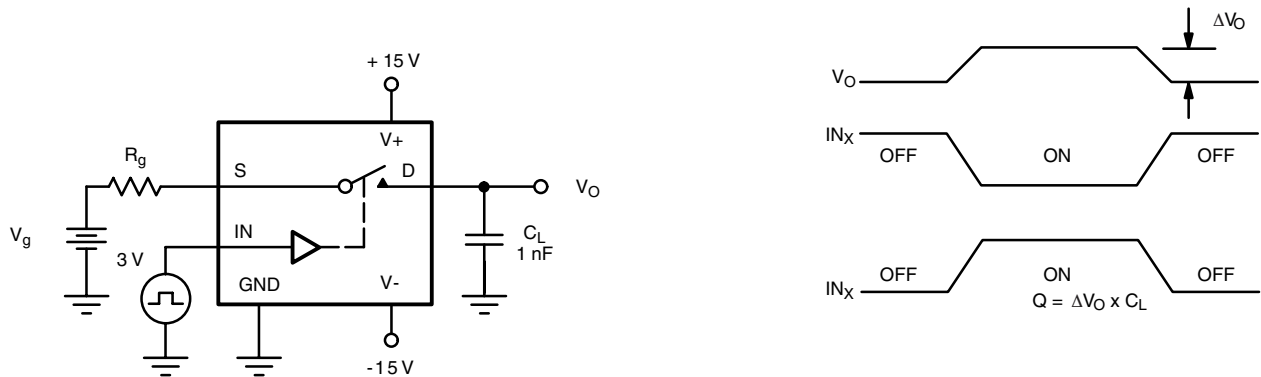

Figure 3. Charge Injection

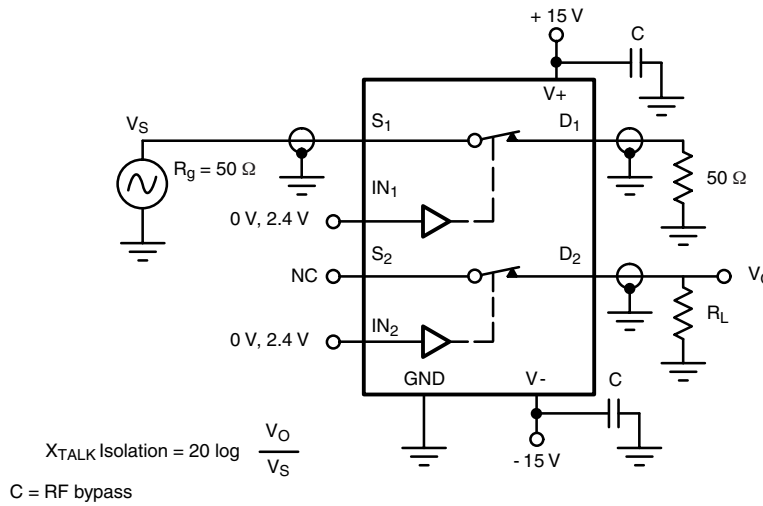

Figure 4. Crosstalk

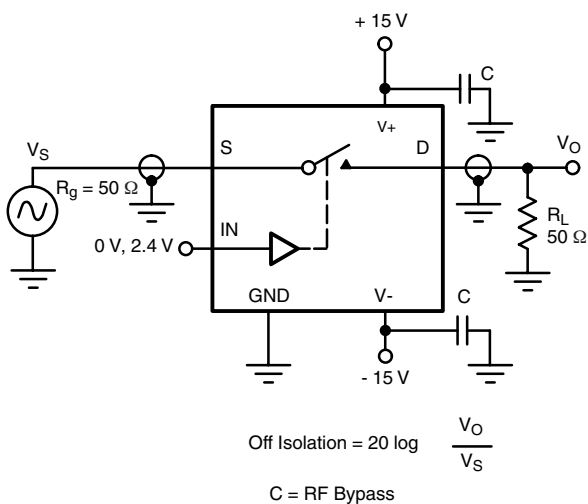

Figure 5. Off-Isolation

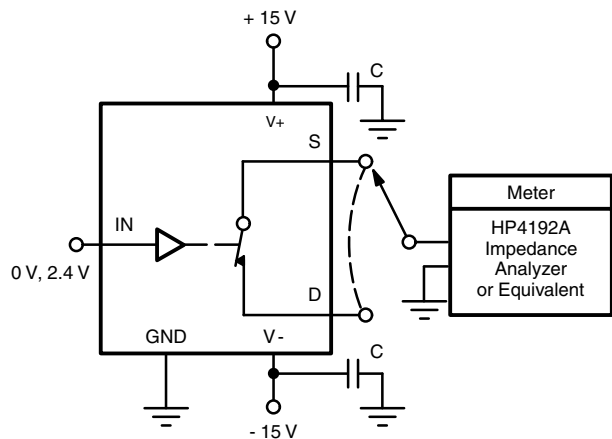

Figure 6. Source/Drain Capacitances

Vishay Siliconix maintains worldwide manufacturing capability. Products may be manufactured at one of several qualified locations. Reliability data for Silicon Technology and Package Reliability represent a composite of all qualified locations. For related documents such as package/tape drawings, part marking, and reliability data, see <http://www.vishay.com/ppg?74473>.





## Notice

Specifications of the products displayed herein are subject to change without notice. Vishay Intertechnology, Inc., or anyone on its behalf, assumes no responsibility or liability for any errors or inaccuracies.

Information contained herein is intended to provide a product description only. No license, express or implied, by estoppel or otherwise, to any intellectual property rights is granted by this document. Except as provided in Vishay's terms and conditions of sale for such products, Vishay assumes no liability whatsoever, and disclaims any express or implied warranty, relating to sale and/or use of Vishay products including liability or warranties relating to fitness for a particular purpose, merchantability, or infringement of any patent, copyright, or other intellectual property right.

The products shown herein are not designed for use in medical, life-saving, or life-sustaining applications. Customers using or selling these products for use in such applications do so at their own risk and agree to fully indemnify Vishay for any damages resulting from such improper use or sale.