

ADNK-3003-ND24

2.4 GHz RF Wireless Optical Mouse Designer's Kit



Design Guide



Introduction

This design guide describes a low power wireless optical mouse design using the new Avago Technologies low power, small form factor ADNS-3000 optical mouse sensor, Nordic Semiconductor NRF24LE1 Ultra Low Power Wireless System-on-Chip Solution and NRF24LU1 single chip 2.4 GHz transceiver. This reference design kit provides a ready-to-use wireless mouse solution in one neat package.

This document provides the reference design for hardware and firmware implementation starting with the basic operations of a optical computer mouse peripheral followed by an introduction to the Avago ADNS-3000 low power optical mouse sensor and the overall design of the wireless reference mouse. The firmware section of this design guide describes the architecture and algorithm of how the firmware of the mouse and the USB dongle functions. Included in Appendix A is the schematic for this reference design mouse and USB dongle.

Features

- Complete wireless optical mouse reference design kit with single AA battery
- Windows® 98SE, Windows 2000 and Windows XP compatibility
- USB 2.0 full-speed compliance
- User identity code to avoid conflict with other devices
- High reliability
- Precise wireless optical navigation technology
- Smooth surface navigation
- Accurate motion up to 30 ips
- Selectable Resolution of up to 2000 cpi
- A high data rate 2.4 GHz RF link

The Functional Blocks of ADNK-3003-ND24 Wireless Optical Mouse

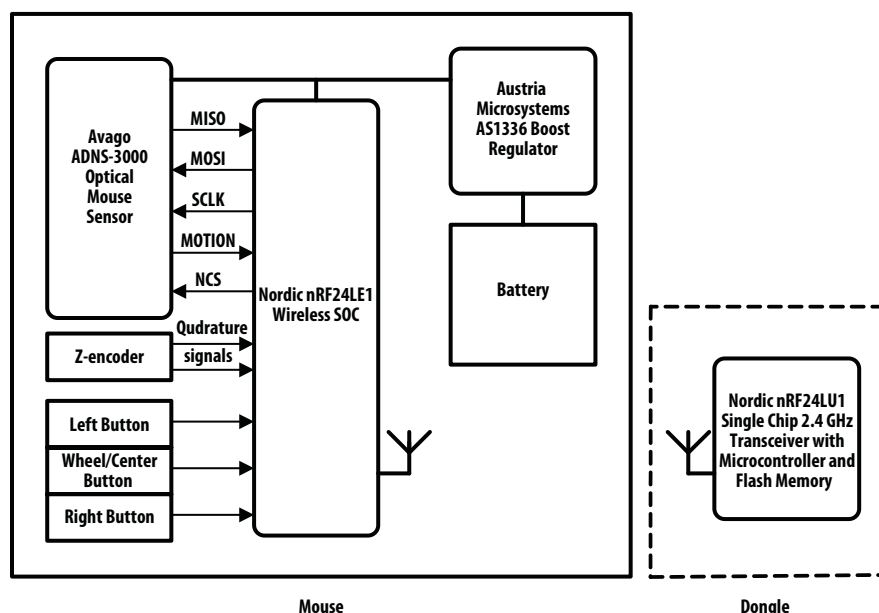

Figure 1. ADNK-3003-ND24 Reference Design Mouse Functional Block Diagram

The functional block diagram of the reference design mouse is shown in Figure 1. The optical sensor detects the X and Y movements. A mechanical Z-wheel with quadrature encoder provides the Z-wheel scroll function. Each of the button switches is pulled high normally and when pressed connects to GND. The AS1336 boost converter regulates the 1.9 V operating voltage supply for the reference design mouse from a single AA alkaline battery in series. The controls and data are transmitted through 2.4 GHz RF by nRF24LE1 used on the mouse side. This will be paired with a nRF24LU1 on the dongle. Both nRF24LE1 and nRF24LU1 are wireless SOCs and contain microcontrollers which is the heart of both the mouse and the dongle

These are the functional blocks of an optical mouse system. The LED illumination source is reflected into the navigation sensor by the surface that the mouse is tracking on. The

sensor and the input devices (namely the input switches and Z-wheel) are interfaced with the microcontroller that processes the data, signals and navigation status before sending them to the computer through the system interface (either the USB, PS2 port or wireless). The final block is the power management block to provide the voltage source to all the ICs and the circuitry of the mouse.

An optical navigation sensor is simply a low resolution intelligent digital camera with a fixed focal length. The camera consists of a CMOS image sensor that captures low resolution images as pixels arrays of up to 30x30 at a certain frame rate (defined as the total of images captured per second) and an on-chip image processing capability to process the sequential images to determine the direction and displacement of motion detected.

Optical Mouse Basics

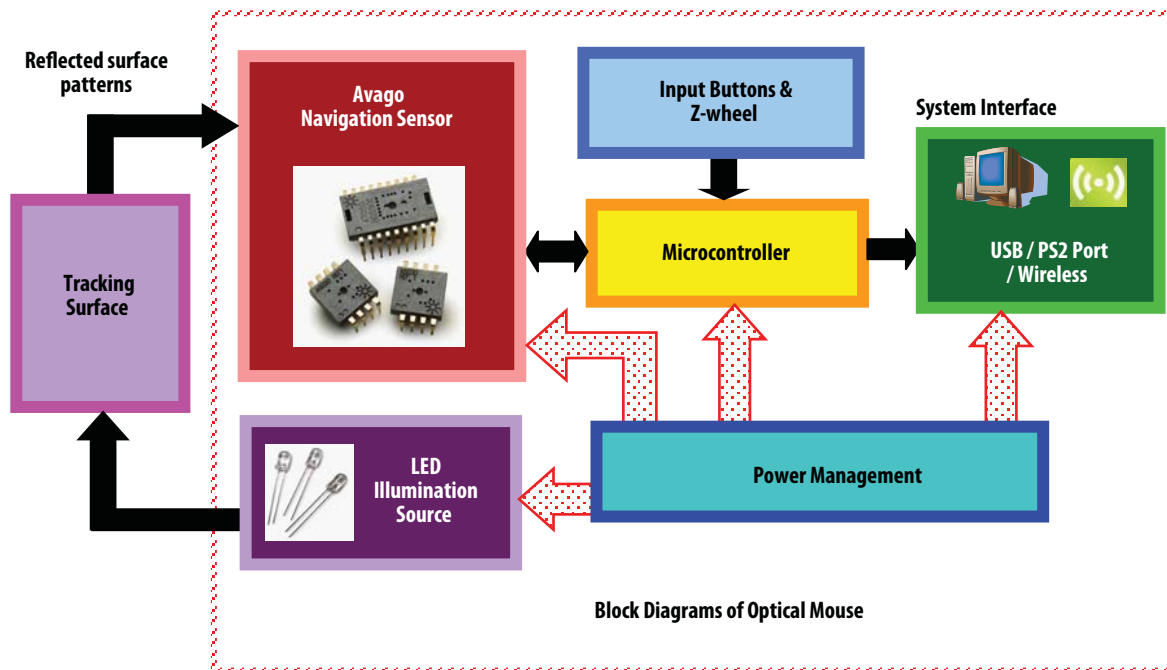

Figure 2. Block Diagrams of Optical Mouse

Mechanical Z-Wheel

The motion of Z-wheel is determined by decoding the quadrature signal generated by the mechanical encoder (or Z-encoder). The Z-wheel is connected to the Z-encoder through its shaft. The rotational movement of the shaft is decoded into on and off levels in a quadrature output pattern. Every change in the Z-encoder outputs represents a count of mouse movement. Comparing the last state of the Z-encoder to the current state derives direction information. As shown in Figure 3, traveling in clockwise direction produces a unique set of state transitions, and traveling in counter clockwise direction produces another set of unique state transitions. In this reference design, only the motion at the Z-wheel is detected using this method.

Mouse Buttons

Mouse buttons are connected as standard switches. These switches are pulled up by the pull up resistors inside the microcontroller. When the user presses a button, the switch will be closed and the pin will be pulled LOW to GND. A LOW state at the pin is interpreted as the button being pressed. A HIGH state is interpreted as the button has been released or the button is not being pressed. Normally the switches are debounced in firmware for 15-20 ms where necessary. In this reference design there are five switches altogether: each for left button, center button (Z-wheel), right button, left side push button for resolution setting and the slide switch at the bottom of the mouse as On/Off switch that cuts off the power from the batteries to the circuitry.

The default resolution setting is 1250 cpi. Pressing the resolution switch (left side push button) once will increase the resolution to 1500 cpi. Pressing again will increase to 1750 cpi and so on repeating the setting in a loop according to the sequence below:

1250 (default), 1500, 1750, 2000, 250, 500, 1000, 1250....

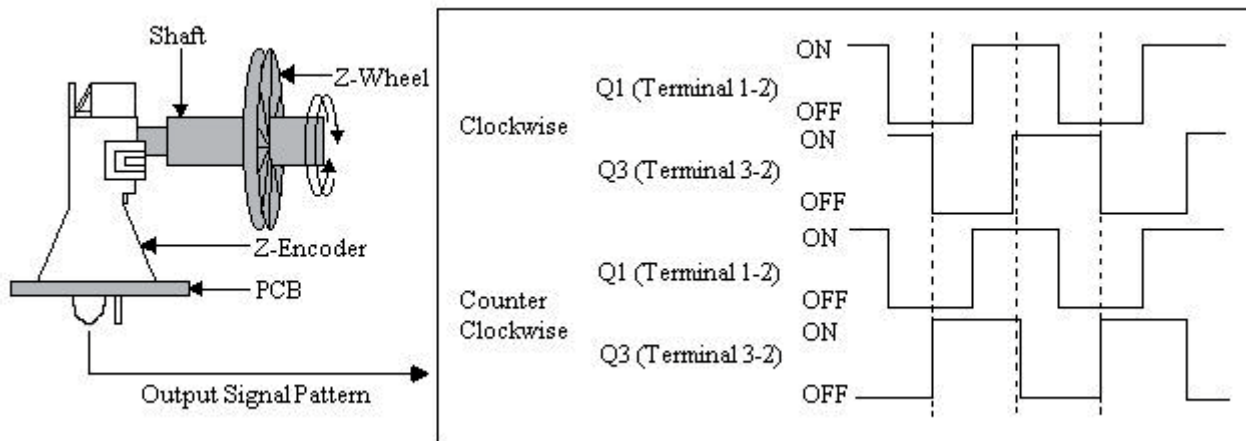

Figure 3. Mechanical Z-Wheel Output Signal Generation

Introduction to Avago ADNS-3000 Low Power Optical Mouse Sensor

Avago's ADNS-3000 optical sensor is used in this reference design as the primary navigation engine. The optical navigation technology contains an Image Acquisition System (IAS), a Digital Signal Processor (DSP), and a two-wire serial port. The input to the sensor is mechanical motion and is captured by the IAS as low resolution image pixel arrays. The DSP then process the sequential images captured by the IAS with its patented image processing algorithm before sending out the digitally processed data over the serial interface. The digital data or output is the horizontal motion information (Delta X) and vertical motion information (Delta Y) from which the direction and speed can be determined.

This motion information will be reported to the PC through the 2.4 GHz RF and USB protocols to update the position of the cursor. The advantages of using ADNS-3000 optical sensor are the efficient power management, good tracking capability and accuracy, good surface coverage and flexibility of programming the optical sensor via the SPI port.

Features include:

- Low Power Architecture
- Smooth surface navigation
- Programmable Periods/ Response Times and Downshift Times from one mode to another for Power Savings
- 'Smart' LED current switching depending on surface brightness
- High Speed Motion Detection of up to 30 ips
- External Interrupt Output for Motion Detection Triggering
- Internal Oscillator – no clock input required
- Selectable Resolution of up to 2000 cpi
- Operating Voltage of As low as 1.7 V
- Two wire Serial Port Interface

To get more technical information on this sensor, please visit the Avago web site at <http://www.avagotech.com>.

Nordic nRF24LE1 Ultra Low Power Wireless System-on-Chip Solution

The nRF24LE1 is a unique solution offering a complete ultra low power (ULP) wireless system-on-chip (SoC) solution. It integrates the industry best nRF24L01+ 2.4 GHz transceiver core, an enhanced 8051 microcontroller, flash memory and a wide range of analog and digital peripherals. The 8-bit microcontroller is powerful enough to run both the RF protocol stack and the application layer, enabling a true single chip implementation of ULP wireless application

The nRF24LE1 is optimized to provide a single chip solution for ULP wireless applications. The combination of processing power, memory, low power oscillators, real-time counter, AES encryption accelerator, random generator, plus a range of power saving modes provides an ideal platform for implementation of RF Protocols. Benefits include tighter protocol timing, security, lower power consumption and improved co-existence performance. For the application layer then nRF24LE1 offers a rich set of peripherals including: SPI, 2-wire, UART, 6 to 12-bit ADC, PWM, and an ultra low power analog comparator for voltage level system wake-up.

Features

- Fully featured ultra low power nRF24L01+ 2.4 GHz transceiver core
- Worldwide 2.4 GHz ISM band operation
- Enhanced ShockBurst™ hardware link layer
- 250 kbps, 1 Mbps and 2 Mbps on-air data rate options
- Air compatible with nRF24L01; nRF24L01+; nRF24LU1, and nRF2401A, -02, -E1 and -E2
- Low cost external +/-60 ppm 16 MHz crystal
- Enhanced 8-bit 8051 compatible microcontroller
- 32-bit multiplication-division unit
- AES encryption/decryption accelerator
- 16 kbytes on-chip flash memory
- 1 kbyte on-chip data flash memory
- 512 bytes high-endurance data flash memory
- 1 kbyte on SRAM plus 256 bytes of IRAM
- Low power 16 MHz crystal and RC oscillators
- Ultra low power 32 kHz crystal and RC oscillators
- Flexible real-time counter and three 16-bit timers/counters
- Ultra low power analog comparator for system wake-up
- Rich set of digital interfaces including: SPI master/slave, 2-wire master/slave, and UART
- 2-channel PWM
- Programmable resolution ADC: 6, 8, 10, or 12-bits
- Random Number Generator based on thermal noise
- Supports the Nordic nRFProbe hardware debugger
- Programmable generic I/O pins

Nordic nRF24LU1 Single Chip 2.4GHz Transceiver with USB Microcontroller and Flash Memory

The nRF24LU1 is a unique single chip solution for compact USB dongles for wireless peripherals. By integrating a nRF24L01 compatible 2.4GHz RF transceiver it supports a wide range of application including PC peripherals, sports accessories and game peripherals.

With air data rate of 2 Mbps combined with full speed USB, supporting up to 12 Mbps, the nRF24LU1 meets performance requirements of applications with stringent performance requirements such as wireless mouse, game controllers and media center remote controls with displays.

Features

- nRF24L01 compatible RF transceiver
- Worldwide 2.4 GHz ISM band operation
- Up to 2 Mbps on air data rate
- Enhanced ShockBurst™ hardware link layer
- Air compatible with nRF24L01, nRF2401A, 02, E1 and E2
- Low cost external ± 60 ppm 16 MHz crystal
- Full speed USB 2.0 compliant device controller
- Up to 12 Mbps USB transfer rate
- 2 control, 10 bulk/interrupt and 2 ISO endpoints
- Dedicated 512 bytes endpoint buffer RAM
- Software controlled pull-up resistor for D+
- PLL for full-speed USB operation
- Voltage regulator, 4.0 to 5.25 V supply range
- Enhanced 8-bit 8051 compatible microcontroller
- Reduced instruction cycle time
- 32-bit multiplication-division unit – 16 kbytes of on-chip flash memory
- 2 kbytes on SRAM
- 6 general purpose digital input/output pins
- Hardware SPI slave and master, UART
- 3 16-bit timers/counters
- AES encryption/decryption co-processor
- Supports firmware upgrade over USB
- Supports FS2 hardware debugger
- Compact 32-pin 5x5 mm QFN package

Wireless RF Technology

This reference design is implemented with Nordic Semiconductor (Nordic) nRF24LE1 System-on-Chip solution. For power saving, nRF24L01A IC is configured to be in power down mode when sensor is in rest modes to minimize the current consumption. When entering this mode the device is not active, but all registers values available from the SPI interface are maintained during power down and the SPI interface may be activated (CSN = 0). The power down is controlled by the PWR_UP bit in the CONFIG register. The nRF24LE1 IC is set to power down mode or lowest power mode when the sensor is in rest modes and activated only during run mode by the microcontroller by setting PWR_UP bit in CONFIG register to 1.

PCB Layout and de-coupling guidelines

A well-designed PCB is necessary to achieve good RF performance. Keep in mind that a poor layout may lead to loss of performance or functionality, if due care is not taken. A fully qualified RF-layout for the nRF24LE1 and nRF24LU1 as well as its surrounding components, including matching networks, can be downloaded from www.nordicsemi.com.

A PCB with a minimum of two layers including a ground plane is recommended for optimum performance. The nRF24LE1 and nRF24LU1 DC supply voltage should be de-coupled as close as possible to the VDD pins with high performance RF capacitors. It is preferable to mount a large surface mount capacitor (e.g. 4.7 μ F tantalum) in parallel with the smaller value capacitors. The nRF24LE1 and nRF24LU1 supply voltage should be filtered and routed separately from the supply voltages of any digital circuitry. Long power supply lines on the PCB should be avoided. All device grounds, VDD connections and VDD bypass capacitors must be connected as close as possible to the nRF24LE1 and nRF24LU1 IC. For a PCB with a top-side RF ground plane, the VSS pins should be connected directly to the ground plane. For a PCB with a bottom ground plane, the best technique is to have via holes as close as possible to the VSS pads. Minimum one via hole should be used for each VSS pin. Full swing digital data or control signals should not be routed close to the crystal or the power supply lines. Refer to the datasheet of nRF24LE1 and nRF24LU1 IC for more information and reference layout design.

Serial Peripheral Interface (SPI)

The nRF24LE1 provides a dedicated hardware-based Serial Peripheral Interface (SPI). The two-wire interface supports byte serial communication in either Master or Slave mode. In this reference design the nRF24LE1 always acts as the master and initiates all SPI communications with external SPI device(s), in this case the ADNS-3000.

Some details on ADNK-3003-ND24

The ADNK-3003-ND24 reference design mouse unit allows users to evaluate the performance of the Optical Tracking Engine (sensor, lens, LED assembly clip, LED) over a USB connection, using a nRF24LE1 System-on-Chip Solution. This kit also enables users to understand the recommended mechanical assembly. (See Appendix C, D, and E)

System Requirements

PCs using Windows® 95/Windows® 98/Windows® NT/Windows® 2000/Windows® XP/Windows® Vista/Windows® 7 with standard 3-button USB mouse driver loaded.

Functionality

3-button, scroll wheel USB-mouse.

USB Operating Mode

Hot pluggable with USB port. The PC does not need to be powered off when enabling/disabling the mouse system. Note: Each mouse has its designated USB dongle (same ID). To ensure proper mouse power on and pairing procedure, firstly insert the dongle into USB port. After 10 seconds, place the mouse next to dongle and click any of the mouse buttons.

To Disassemble the ADNK-3003-ND24 Unit

The ADNK-3003-ND24 comprises of the plastic mouse casing, 3 pieces of printed circuit boards (PCB), lens, buttons, and batteries (See Figure 4). Unscrewing the one screw located at the base of the unit can open the ADNK-3003-ND24 mouse unit. Lifting and pulling the PCB carefully out of the base plate can further disassemble the mouse unit.

While reassembling the components, please make sure that the Z-height (distance from lens reference plane to surface) is valid. Refer to Figure 5. Screwing back the two screws appropriately on the optical sensor PCB sub-board can lock it tightly on the mouse base plate.

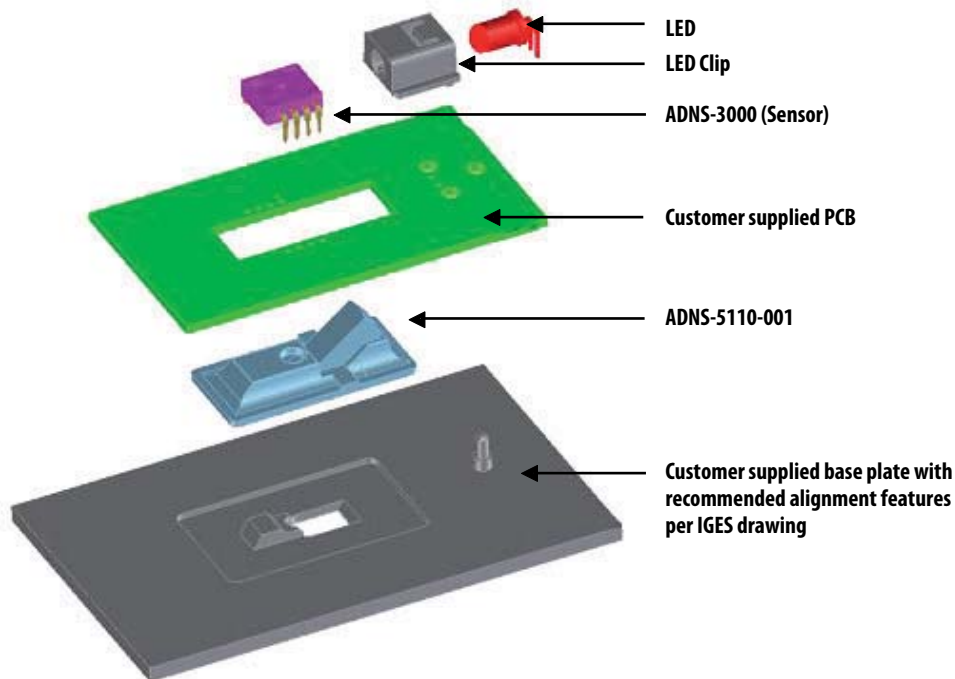
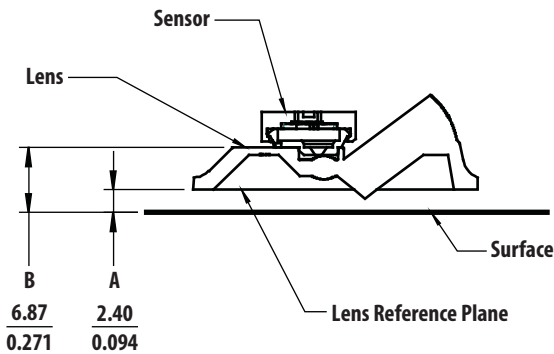

Figure 4. Exploded view drawing of optical tracking engine with ADNS-3000 Optical mouse sensor



Note:

A – Distance from object surface to lens reference plane

B – Distance from object surface to sensor reference plane

Figure 5. Distance from lens reference plane to surface

Regulatory Requirements

- Passes FCC B and worldwide analogous emission limits when assembled into a mouse with shielded cable and following Avago Technologies recommendations.
- UL flammability level UL94 V-0.

Below is the summary of the components contained in the ADNK-3003-ND24 Designer's Kit.

Sensor

The sensor technical information is contained in the ADNS-3000 Data Sheet.

Microcontroller and RF Transceiver SOC

Technical information on the Nordic Semiconductor nRF24LE1 and nRF24LU1 is detailed in the datasheets. The RF design considerations are available in the application notes that can be found in Nordic's website.

Lens

The lens technical information is contained in the ADNS-5110-001 Data Sheet.

LED Assembly Clip

The information on the assembly clip is contained in the ADNS-5200 Data Sheet.

LED

The LED technical information is contained in the HLMP-EG3E and HSDL-4261 Data Sheet. Application Note AN5492 provides additional relevant information regarding ADNS-3000 Eye Safety Calculations.

Base Plate Feature – IGES File

The IGES file on the CD-ROM provides recommended base plate molding features to ensure optical alignment. This includes PCB assembly diagrams like solder fixture in assembly and exploded view, as well as solder plate. See Appendix D for details.

Overall circuit

The schematics of the overall circuit for mouse and USB dongle are shown in Appendix A of this document. Appendix B lists the bill of materials.

Reference Design Documentation – Gerber Files

The Gerber File presents detailed schematics used in ADNK-3003-ND24 in PCB layout form. See Appendix C for more details.

Firmware Implementation

The firmware for this reference design is written in the C language. The following files are required to compile the mouse firmware.

gazell/common/gzll.c – Gazell Link Layer implementation

gazell/common/gzll.h – Gazell Link Layer header file

gazell/common/gzll_params_tmpl.h – Gazell Link Layer default parameters template file

gazell/common/gzp.c – Implementation of Gazell pairing library common Device and Host functions

gazell/common/gzp.h – Gazell pairing library header file

gazell/common/gzp_device.c – Implementation of Gazell Pairing Library (gzp), Device functions

gazell/common/gzp_host.c – Implementation of Gazell Pairing Library (gzp), Host functions

gazell/common/gzp_params_tmpl.h

gazell/nrf24le1/gzll_macros.h – Gazell Link Layer nRF24LE1 specific macros

gazell/nrf24le1/gzll_mcu.c – Gazell Link Layer nRF24LE1 specific functions implementation

gazell/nrf24le1/gzll_mcu.h – Gazell Link Layer MCU setup header file

gazell/nrf24le1/gzll_radio_isr.c – Gazell Link Layer nRF24LE1 radio interrupt service routine

gazell/nrf24le1/gzll_timer_isr.c – Gazell Link Layer nRF24LE1 radio interrupt service routine

gazell/nrf24le1/gzp_device_le1.c – Implementation of nRF24LE1 specific Device functions for the Gazell pairing library

gazell/nrf24le1/gzp_host_le1.c – Implementation of nRF24LU1+ specific Device functions for the Gazell pairing library

gazell/nrf24lu1/gzll_macros.h – Gazell Link Layer nRF24LU1+ specific macros

gazell/nrf24lu1/gzll_mcu.c – Implementation of Gazell Link Layer nRF24LU1+ specific functions

gazell/nrf24lu1/gzll_mcu.h – Gazell Link Layer MCU setup header file

gazell/nrf24lu1/gzll_radio_isr.c – Gazell Link Layer nRF24LU1+ radio interrupt service routine

gazell/nrf24lu1/gzll_timer_isr.c – Gazell Link Layer nRF24LU1+ timer interrupt service routine

gazell/nrf24lu1/gzp_host_lu1.c

hal/nordic_common.h – Common defines and macros for firmware developed by Nordic Semiconductor

hal/misc/adns3000/hal_adns3000.c – Sensor initialization, CPI event, Read Motion data.

hal/misc/adns3000/hal_adns3000.h

hal/nrf24l01p/hal_nrf.c – Implementation of hal_nrf

hal/nrf24l01p/hal_nrf.h – Interface functions for the on-chip radio transceiver

hal/nrf24l01p/hal_nrf_reg.h – Register definitions for nRF24L01+

hal/nrf24le1/hal_adc.c – Implementation of hal_adc

hal/nrf24le1/hal_adc.h – Interface functions for the analog-to-digital converter (ADC)

hal/nrf24le1/hal_aes.c – Implementation of hal_aes

hal/nrf24le1/hal_aes.h – Interface functions for encrypting data using the Advanced Encryption Standard (AES) hardware module(s)

hal/nrf24le1/hal_ancmp.c – Implementation of hal_ancmp

hal/nrf24le1/hal_ancmp.h – Interface functions for the analog comparator

hal/nrf24le1/hal_clk.c – Implementation of hal_clk

hal/nrf24le1/hal_clk.h – Interface for clock management

hal/nrf24le1/hal_flash.c – Implementation of hal_flash

hal/nrf24le1/hal_flash.h – Interface for self-programming of on-chip Flash / Non Volatile Data Memory

hal/nrf24le1/hal_flash_hw.h – Header file defining flash parameters for nRF24LE1

hal/nrf24le1/hal_nrf_hw.c – Implementation of hal_nrf_hw

hal/nrf24le1/hal_nrf_hw.h – Macros and hardware includes for nRF24LE1

hal/nrf24le1/hal_pof.c – Implementation of hal_pof

hal/nrf24le1/hal_pof.h – Interface for Power-fail comparator

hal/nrf24le1/hal_rng.c
Implementation of hal_rng

hal/nrf24le1/hal_rng.h – Interface functions for the true random number generator

hal/nrf24le1/hal_rtc.c – Implementation of hal_rtc

hal/nrf24le1/hal_rtc.h – Interface functions for the real-time clock

hal/nrf24le1/hal_spi.c – Implementation of hal_spi

hal/nrf24le1/hal_spi.h – Interface functions for the Serial Peripheral Interface (SPI)

hal/nrf24le1/hal_uart.c – Implementation of hal_uart

hal/nrf24le1/hal_uart.h – Interface functions for the Universal Asynchronous Receiver-Transmitter (UART)

hal/nrf24le1/hal_w2.c – Implementation of hal_w2

hal/nrf24le1/hal_w2.h – Interface for the 2-Wire module

hal/nrf24le1/hal_wdog.c – Implementation of hal_wdog

hal/nrf24le1/hal_wdog.h – Interface functions for the watchdog

hal/nrf24lu1p/cklf.c – Implementation of the cklf module for nRF24LU1+

hal/nrf24lu1p/cklf.h – Interface functions for the low frequency clock module

hal/nrf24lu1p/cpu.c – Implementation of the cpu module for nRF24LU1+

hal/nrf24lu1p/cpu.h – CPU management functions

hal/nrf24lu1p/hal_aes.c – Implementation of hal_aes for nRF24LU1+

hal/nrf24lu1p/hal_aes.h – Interface functions for encrypting data using the Advanced Encryption Standard (AES) hardware module – hal/nrf24lu1p/hal_flash.c – Implementation of hal_flash for nRF24LU1+ hal/nrf24lu1p/hal_flash.h – Interface functions for self-programming of on-chip Flash

hal/nrf24lu1p/hal_flash_hw.h – Header file defining flash parameters for nRF24LU1+

hal/nrf24lu1p/hal_nrf_hw.c – Implementation of hal_nrf_rw for nRF24LU1+

hal/nrf24lu1p/hal_nrf_hw.h – Hal_nrf macros for nRF24LU1+

hal/nrf24lu1p/hal_spi.c – Implementation of the SPI HAL module for nRF24LU1+

hal/nrf24lu1p/hal_spi.h – Interface functions for the Serial Peripheral Interface (SPI)

hal/nrf24lu1p/hal_uart.c – Implementation of the UART HAL module for nRF24LU1+ with data buffering

hal/nrf24lu1p/hal_uart.h – Interface functions for the Universal Asynchronous Receiver-Transmitter (UART)

hal/nrf24lu1p/hal_uart_sync.c – Implementation of the UART HAL module for nRF24LU1+ without data buffering

hal/nrf24lu1p/hal_usb.c – Implementaion of the USB HAL

hal/nrf24lu1p/hal_usb.h – Interface for the USB device controller

hal/nrf24lu1p/hal_usb_desc.h – This file contain structures and constants defined in Chapter 9 of the USB 2.0 standard

hal/nrf24lu1p/hal_usb_hid.c – Function for handling HID device requests

hal/nrf24lu1p/hal_usb_hid.h – This file contain functions to handle USB HID related requests

hal/nrf24lu1p/hal_usb_hid_desc.h – This file define USB HID related structures

hal/nrf24lu1p/usb.h – This file contain definitions related to the USB-controller and internal structures

hal/nrf24lu1p/usb_map.h – USB register layout and interrupts

lib/assertions/assertions.h – An assertions library

lib/assertions/assertions_setup.h – Definition of compiler specific macros for assertion library

projects/nrfready/common_setup/gzpair_params.h

projects/nrfready/common_setup/nrfr_common_gzll_params.h
projects/nrfready/common_setup/nrfr_common_gzp_params.h
projects/nrfready/common_setup/nrfr_profiles.h
projects/nrfready/dongle/config.h
projects/nrfready/dongle/gzll_macros.h
projects/nrfready/dongle/gzll_mcu.c
projects/nrfready/dongle/gzll_params.h
projects/nrfready/dongle/gzp_params.h
projects/nrfready/dongle/main.c
projects/nrfready/dongle/nrfr_data_report_desc.h
projects/nrfready/dongle/nrfr_keyboard_report_desc.h
projects/nrfready/dongle/nrfr_mouse_report_desc.h
projects/nrfready/dongle/nrfr_remote_report_desc.h
projects/nrfready/dongle/usb_desc.c
projects/nrfready/dongle/usb_desc.h
projects/nrfready/dongle/usb_hid_desc.h
projects/nrfready/keyboard/gzll_params.h
projects/nrfready/keyboard/gzp_params.h
projects/nrfready/keyboard/main.c
projects/nrfready/keyboard/nrfr_keyboard.c
projects/nrfready/keyboard/nrfr_keyboard.h
projects/nrfready/mouse/gzll_params.h
projects/nrfready/mouse/gzp_params.h
projects/nrfready/mouse/main.c
projects/nrfready/mouse/nrfr_mouse.c
projects/nrfready/mouse/nrfr_mouse.h
projects/nrfready/mouse/config_init.h – Pairing ID Configuration
projects/nrfready/remote/gzll_params.h
projects/nrfready/remote/gzp_params.h
projects/nrfready/remote/main.c
projects/nrfready/remote/nrfr_remote.c
projects/nrfready/remote/nrfr_remote.h
projects/nrfready/remote/nrfr_remote_hid_table.c – The conversion table between remote control messages and HID reports is located here

The user should insert the receiver dongle into an available USB port at the computer. Install an AA alkaline battery into the battery compartment. Pay special attention to the polarities of the battery. The reference design mouse is designed to work with either one or two AA batteries in parallel. The USB receiver dongle will be detected by the PC as HID. The PC will automatically detect the mouse once the mouse is properly “connected” to the dongle via the wireless RF. For longer battery life, turn off the mouse using the On/Off switch at the bottom side of the mouse when the mouse is not in use. Replace the batteries when the battery power is low and incapable of navigation.

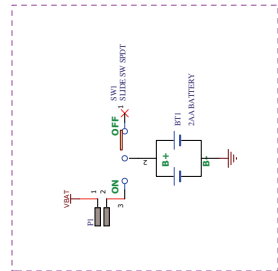

△ 2x AA Battery

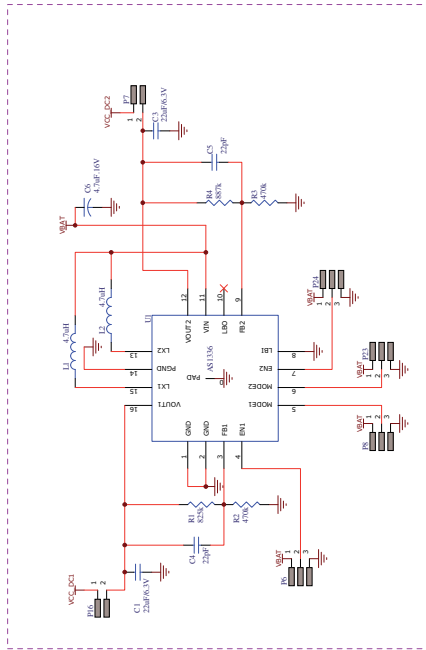

△ 2.2V / 2.3V Regulator Block

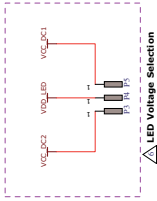
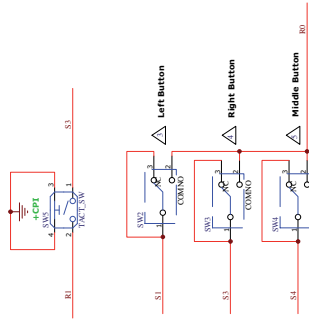

△ LED Voltage Selection

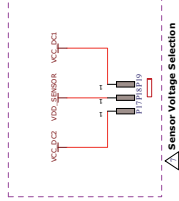

△ Sensor Voltage Selection

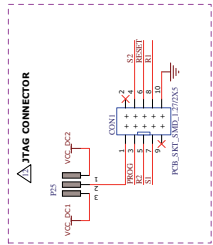
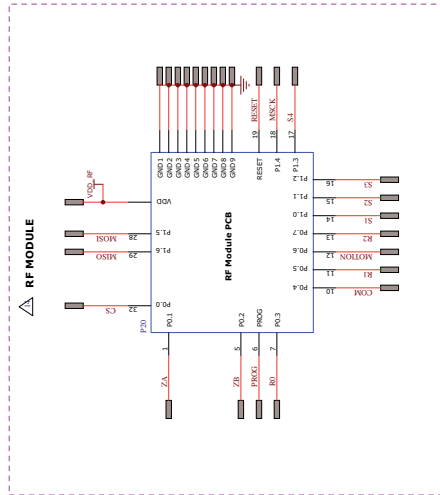

△ JTAG CONNECTOR

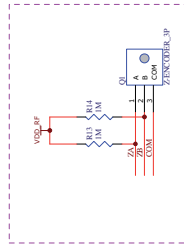

△ Z-Encoder

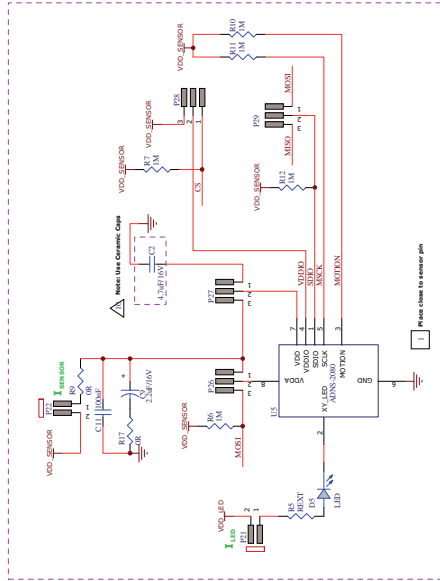

△ Sensor Block

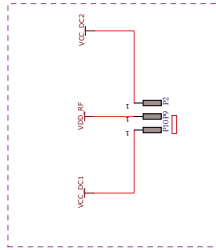

△ RF Voltage Selection

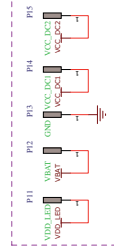

△ Voltage Measurement

Figure A1. Circuit diagram of the mainboard

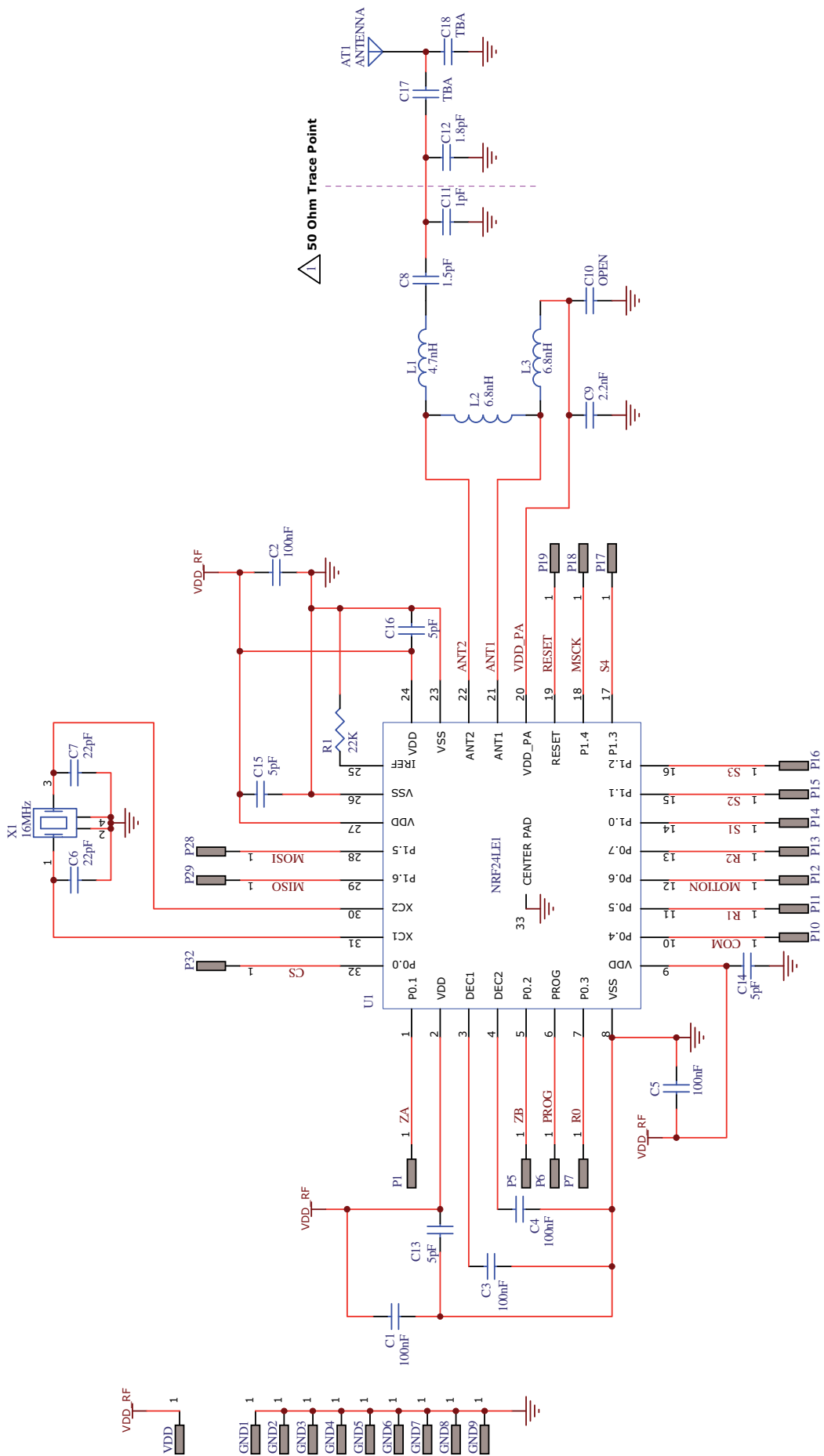
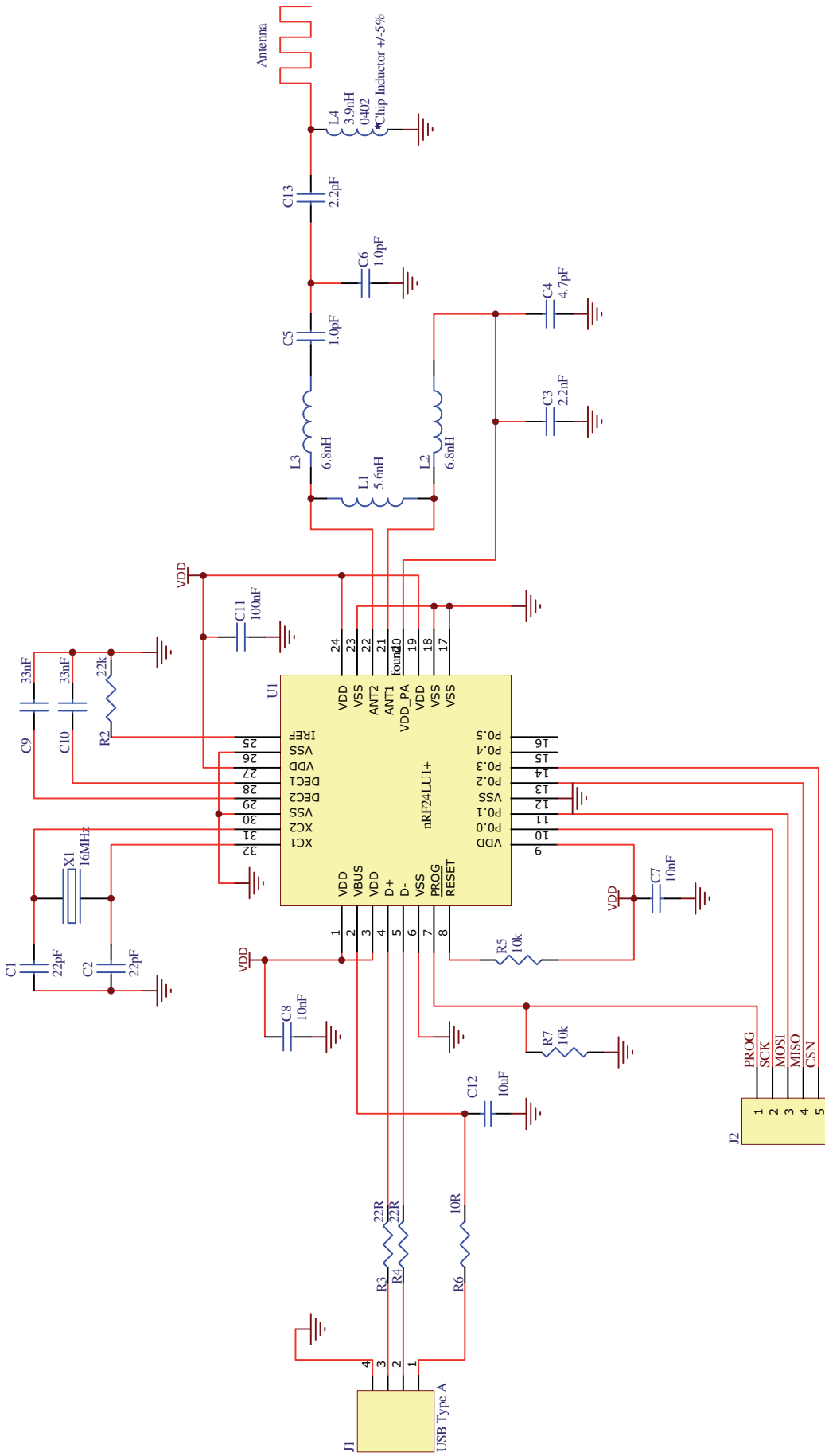

Figure A2. Circuit diagram of the Nordic nRF24LE1 SoC RF module



FigureA3. Circuit diagram of the nRF24LU1 SoC in ADNIK-3003-ND24 USB Dongle

Appendix B: Bill of Materials for ADNK-3003-ND24 Wireless Optical Mouse Designer's Kit

Table B1. Bill of materials for ADNK-3003-ND24 Wireless Optical Mouse main board

No	Part Description	RoHS	Footprint	Designator	Quantity
1	Capacitor Ceramic 0603 22 pF 50 V NP0	Yes	0603	C4, C5	2
2	Capacitor Ceramic 0603 100 nF 50 V X7R	Yes	0603	C11	1
3	Capacitor Ceramic 0603 4.7 μ F 10 V X5R	Yes	0603	C2	1
4	Capacitor Tantalum Case-A 2.2 μ F 16 V 20%	Yes	CASE-A	C9	1
5	Capacitor Tantalum Case-A 4.7 μ F 16 V 10%	Yes	CASE-A	C6	1
6	MLCC, 0805, X5R, 6.3 V, 22 μ F	Yes	0805	C1, C3	2
7	PCB Socket 1.27 mm 2 x 5 way, SMD, H x 3.6 mm	Yes	PCB_SKT_SMD_1.27/2X5	CON1	1
8	Power Inductors 1210 4.7 μ H 30%	Yes	1210	L1, L2	2
9	PCB, P-AFX-4744M-01-Rev1	Yes	-	-	1
10	Resistor 0402 1M 1% 0.063 W	Yes	0402	R6, R7, R10, R11, R12, R13, R14	7
11	Resistor 0603 887k 1% 0.1 W Thick Film	Yes	0603	R4	1
12	Resistor 0603 0R	Yes	0603	R9, R17	2
13	Resistor 0603 470k 1% 0.1 W Thick Film	Yes	0603	R2, R3	2
14	Resistor 0603 66R5 1% 0.063 W Thick Film	Yes	0603	R5	1
15	Resistor 0603 649k 1% 0.063 W Thick Film	Yes	0603	R1	1
16	Dual, Low Voltage, Micropower DC-DC Step-Up Converters	Yes	TDFN-16 3x3 mm	U1	1
17	Micro Switch SPDT Pin Plunger 0.75N	Yes	TH_D2F-F	SW2, SW3, SW4	3
18	Slide Switch SPDT Ultra Miniature (Pitch 2.54 mm)	Yes	TH_SS-12SDP	SW1	1
19	Tactile Switch SPNO 1N H 7.4 mm x W 7.3 mm Projected Plunger R/A	Yes	TH_B3F-3150	SW5	1
20	ADNS-3000	N/A	ADNS-3000	U5	1
21	LED 5 mm IR	No	LED_5MM	D5	1
22	Black LED Clip	No	-	D5	1
23	Mechanical Z-Encoder	TBA	Z-ENCODER_3P	Q1	1

Table B2. Bill of materials for ADNK-3003-ND24 Wireless Optical Mouse main board's RF module

No	Description	RoHS	F.Print	Designator	Set Qty
1	Capacitor Ceramic 0402 1 pF 50 V C0G	Yes	0402	C11	1
2	Capacitor Ceramic 0402 2.2 nF 50 V X7R	Yes	0402	C9	1
3	Capacitor Ceramic 0402 100 nF 16 V Y5V	Yes	0402	C1, C2, C3, C4, C5	5
4	Capacitor Ceramic 0402 1.8 pF 50 V	No	0402	C12	1
5	Capacitor Ceramic 0402 22 pF 50 V C0G 5%	Yes	0402	C6, C7	2
6	Capacitor Ceramic 0402 1.5 pF 50 V C0G ± 0.25 pF	Yes	0402	C8	1
7	Capacitor Ceramic 0402 5 pF 50 V NP0 ± 0.5 pF	Yes	0402	C13, C14, C15, C16	4
8	Crystal SMD 16 MHz (C3E 3.2 mm x 2.5 mm)	Yes	SMD_CE3_3.2 mm x 2.5 mm	X1	1
9	Inductor 0402 6.8 nH High Frequency (LPQ15 Series)	Yes	0402	L2, L3	2
10	Inductor 0402 4.7 nH High Frequency (ILC Series)	Yes	0402	L1	1
11	PCB, P-AFX-4572M-02-Rev1	Yes	N/A	N/A	1
12	Resistor 0402 22k 1% 0.063 W	Yes	0402	R1	1
13	Ultra-low Power Wireless System On-Chip Solution	Yes	QFN-32	U1	1

Table B3. Bill of materials for ADNK-3003-ND24 Wireless Optical Mouse dongle RF module

No	Description	RoHS	F.Print	Designator	Set Qty
1	Capacitor Ceramic 0402 1 pF 50 V C0G	Yes	0402	C5, C6	2
2	Capacitor Ceramic 0402 2.2 pF 50 V NP0	Yes	0402	C13	1
3	Capacitor Ceramic 0402 4.7 pF 50 V NP0	Yes	0402	C4	1
4	Capacitor Ceramic 0402 2.2 nF 50 V X7R	Yes	0402	C3	1
5	Capacitor Ceramic 0402 33 nF 16 V Y5V	Yes	0402	C9, C10	2
6	Capacitor Ceramic 0402 100 nF 16 V Y5V	Yes	0402	C11	1
7	Capacitor Ceramic 0402 10 nF 50 V X7R 10%	Yes	0402	C7, C8	2
8	Capacitor Ceramic 0603 10 μ F 6.3 V X5R 20%	Yes	0603	C12	1
9	Capacitor Ceramic 0402 22 pF 50 V C0G 5%	Yes	0402	C1, C2	2
10	Header 1 mm 5way SMD (SH Series)	Yes	HDR/S_1_1X5_SH	J2	1
11	PLUG, USB, TYPE A, R/A	Yes	ACIN USD SMD	J1	1
12	Crystal SMD 16 MHz (C3E 3.2 mm x 2.5 mm)	Yes	SMD_CE3_3.2 mm x 2.5 mm	X1	1
13	Inductor 0402 5.6 nH High Frequency (LPQ15 Series)	Yes	0402	L1	1
14	Inductor 0402 6.8 nH High Frequency (LPQ15 Series)	Yes	0402	L2, L3	2
15	Inductor 0402 3.9 nH High Frequency (ATFC-0402 Series)	Yes	0402	L4	1
16	PCB, P-4572M-C01-Rev1, 4 Layer (Refer to 18-000396)	Yes	N/A	-	1
17	Resistor 0402 22k 1% 0.063 W	Yes	0402	R2	1
18	Resistor 0402 22R 1% 0.063 W	Yes	0402	R3, R4	2
19	Resistor 0402 10k 5% 0.063 W Thick Film	Yes	0402	R5, R7	2
20	Resistor 0402 10R 5% 0.063 W Thick Film	Yes	0402	R6	1
21	Single Chip 2.4 GHz Transceiver with USB Microcontroller and Flash Memory	Yes	QFN-32	U1	1

Appendix C: PCB Layout

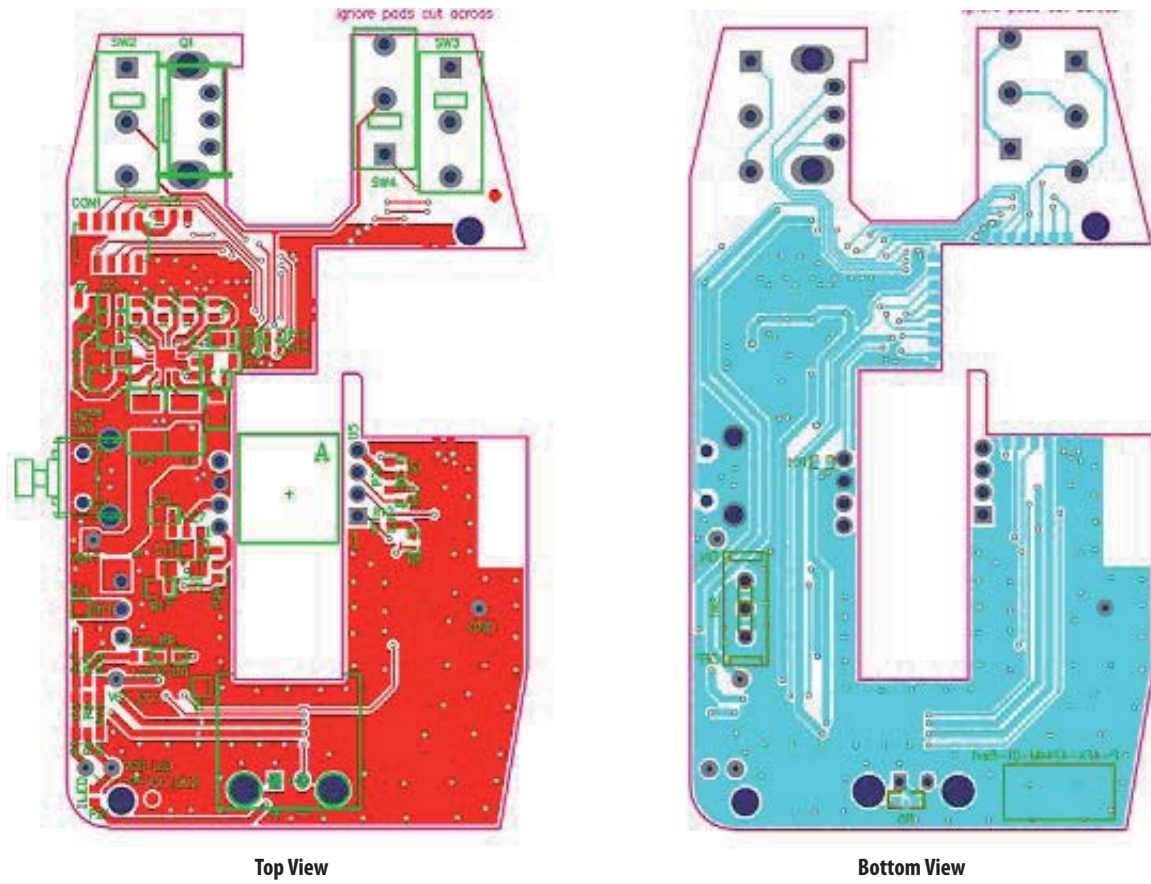

Figure C1. PCB layout for main board of ADNK-3003-ND24 wireless Optical mouse designer's kit

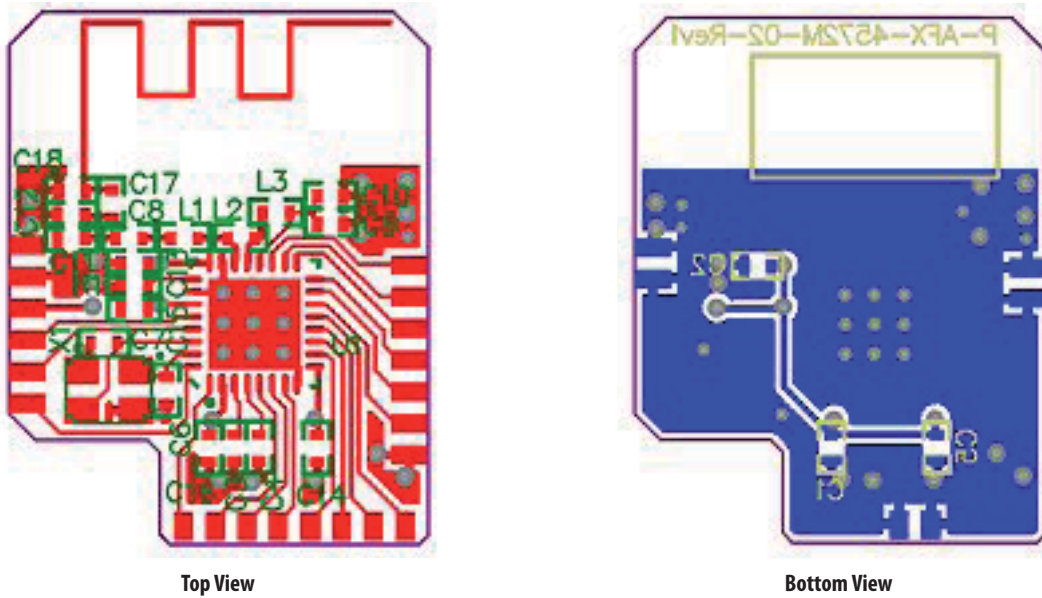
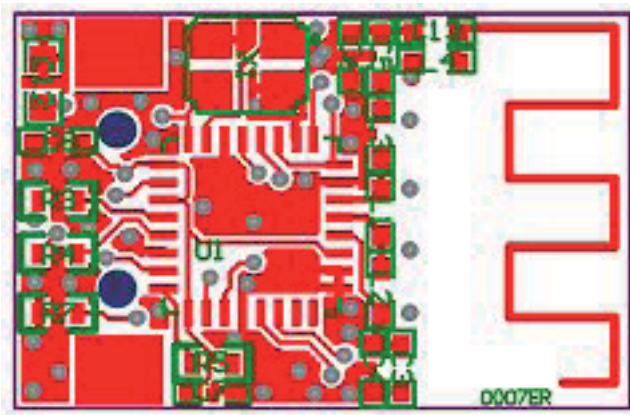
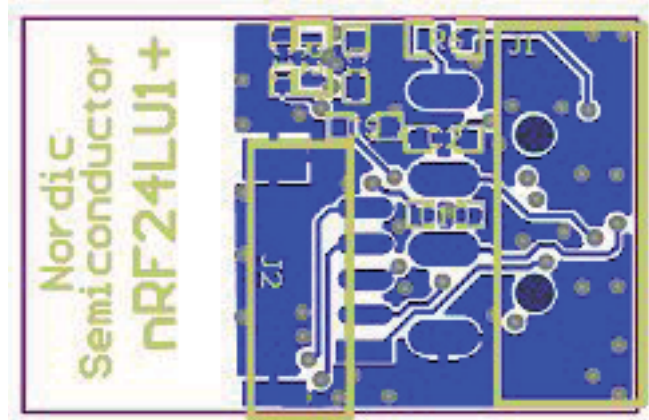

Figure C2. PCB layout ADNK-3003-ND24 Designer's Kit RF module



Top View



Bottom View

Figure C3. PCB layout ADNK-3003-ND24 Designer's Kit dongle

Appendix D: Base Plate Feature

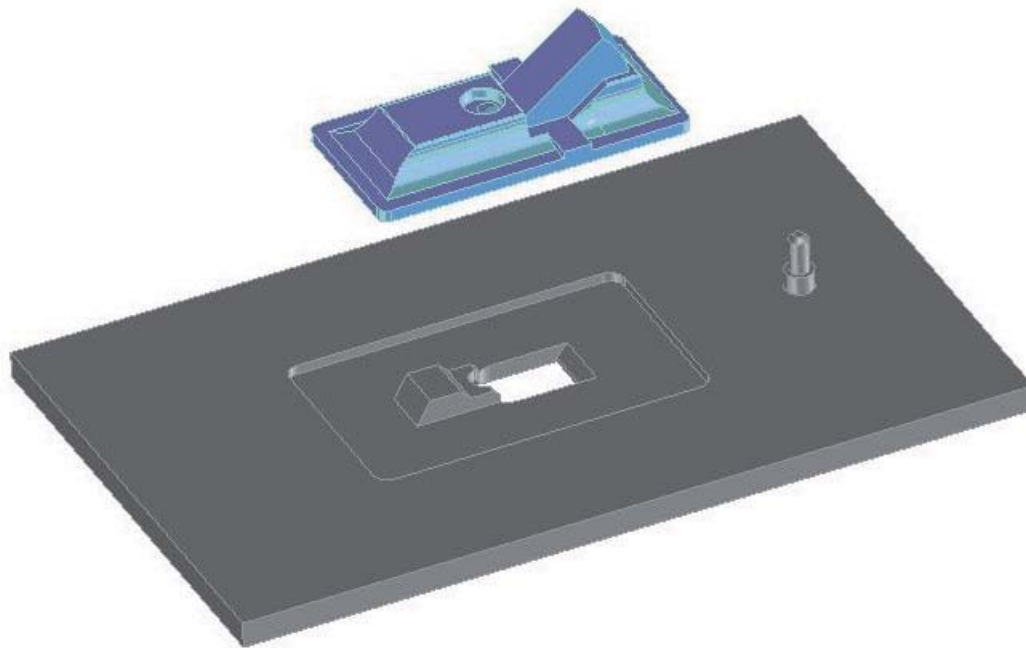

Figure D1. Illustration of base plate mounting features for ADNS-5110-001 optical mouse trim lens

Appendix E: Sectional view of PCB assembly

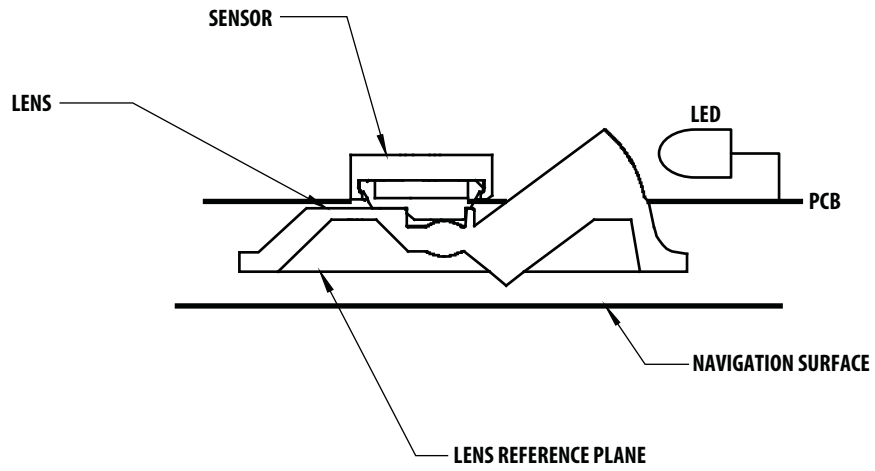

Figure E1. Optical System Assembly Cross Sectional View

Appendix F: Kit Components

The designer's kit contains components as follows:

Part Number	Description	Name	Quantity
ADNK-3003-ND24 Mouse Set	a. Wireless Optical Mouse b. USB Dongle	Reference Design Mouse Set	1
ADNS-3000	Optical Mouse Sensor	Sensor	5
ADNS-5110-001	Optical Mouse Trim Lens Plate	Lens	5
ADNS-5200	Optical Mouse LED Assembly Clip (Black)	LED Clip	5
HLMP-EG3E	Red LED	LED	5
ADNK-3003-ND24 CD-ROM	Includes Documentation and Support Files for ADNK-3003-ND24 Documentations a. ADNS-3000 Low Power Optical Mouse Sensor Data Sheet b. ADNK-3003-ND24 Optical Mouse Designer's Kit Design Guide c. ADNS-3000 Eye Safety Application Note (AN 5492) d. ADNS-5110-001 Trim Lens Data Sheet e. ADNS-5200 Data Sheet f. HLMP-EG3E Red LED Data Sheet g. Nordic Semiconductor nRF24LE1 SOC RF Transceiver Data Sheet h. Nordic Semiconductor nRF24LU1 SOC RF Transceiver Data Sheet Hardware Support Files a. ADNK-3003-ND24 BOM List b. ADNK-3003-ND24 Schematic c. ADNK-3003-ND24 Gerber File d. IGES for 3D Assembly, ADNS-5110-001 Lens and Base Plate Feature Software Support Files a. Mouse Firmware – Nordic nRF24LE1 2.4 GHz SOC b. USB Dongle Firmware – Nordic nRF24LU1 2.4 GHz SOC		1

For product information and a complete list of distributors, please go to our web site: www.avagotech.com

Avago, Avago Technologies, and the A logo are trademarks of Avago Technologies in the United States and other countries.
 Data subject to change. Copyright © 2005-2010 Avago Technologies. All rights reserved.
 AV02-2751EN - December 2, 2010

