



General Description

The DSC1123 is a silicon MEMS based LVDS oscillator offering excellent jitter and stability performance over a wide range of supply voltages and temperatures. The device operates from 10 to 425MHz in increments of 100Hz (up to four decimal point resolution) with supply voltages between 2.5V to 3.3 Volts.

Available in industry standard 7X5mm and 5X3.2 packages, the DSC1123 is a "drop-in" replacement for a standard 6 pin quartz oscillator. Employing semiconductor packaging techniques, the DSC1123 is also available in a 3.2X2.5mm package that is the industry's smallest package for differential output devices.

Block Diagram

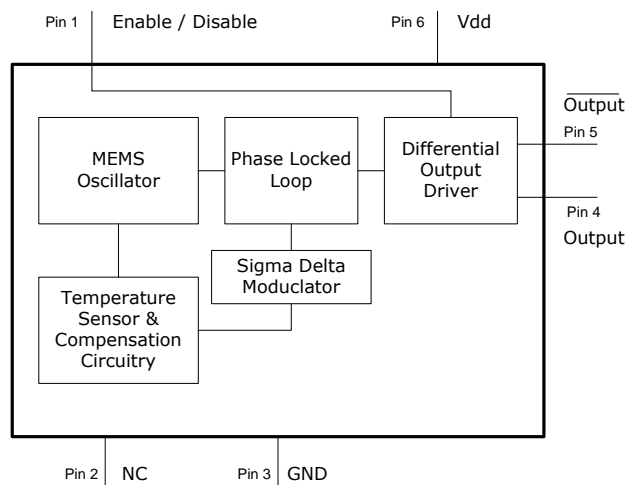

Enable Function

Enable (pin 1)	Outputs (pin 4 & 5)
Hi Level	Outputs Active
Open (no connect)	Outputs Active
Low Level	High Impedance

Features

- Frequency Range: 10 to 425MHz
- Low Integrated Phase Noise Jitter
 - <3 ps rms: 12kHz to 20MHz
 - <1 ps rms: 100kHz to 20MHz
 - <0.7 ps rms: 200kHz to 20MHz
- Current: <40ma
- Output Enable/Disable Function
- Operating voltage
 - 2.25 to 3.60V (absolute max)
- Exceptional Stability over Temperature
 - ±20 PPM, ±25 PPM ±50 PPM
- Operating Temperature Range
 - Industrial -40°C to 85°C
 - Ext. Commercial -20°C to 70°C
 - Commercial 0°C to 70°C
- Ultra Miniature Footprint
 - 3.2 x 2.5 x 0.85 mm
 - 5.0 x 3.2 x 0.85 mm
 - 7.0 x 5.0 x 0.85 mm
- Lead Free, RoHS & Reach SVHC Compliant
- IBIS Models will be available
- LVPECL & HCSL versions available

Benefits

- Pin for pin "drop in" replacement for industry standard 6 pin oscillators
- Frequency Resolution to 4 decimals
- Small Plastic package
- Cost Effective Solution
- Excellent Immunity to Mechanical Shock and Vibration
- Semiconductor level reliability, significantly better than quartz

Applications

- 10G/1G Ethernet
- Storage Area Networks
- PON
- Server & Storage Platforms
- HD Video
- SAS / Fibre Channel

Absolute Maximum Ratings

Item	Min.	Max	Unit	Condition
Supply Voltage	-0.3	+4.0	V	
Input Voltage	-0.3	VDD+0.3	V	
Junction Temp	-	+150	°C	
Storage Temp	-55	+150	°C	
Soldering Temp	-	+260	°C	40 sec max.
ESD	-		V	
HBM		2000		
MM		200		
CDM		500		

Ordering Code

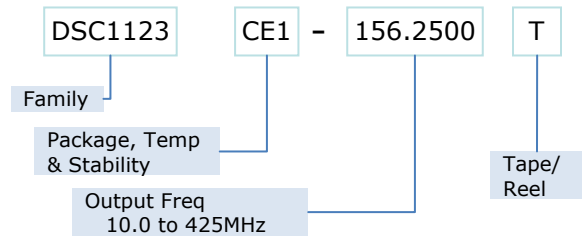

* See Ordering Information for details

Specifications

Parameter	Symbol	Condition	Min.	Typ.	Max.	Unit
Supply Voltage ¹	V _{DD}		2.25		3.6	V
Supply Current	I _{DD}	R _L =100Ω T=25°C		28	40	mA
Frequency	f ₀	Single Frequency	10		425	MHz
Frequency Tolerance Industrial Extended Commercial Commercial	Δf	-40°C to +85°C -20°C to +70°C 0°C to +70°C			±20,±25,±50 ±20,±25,±50 ±20,±25,±50	ppm
Output Offset Voltage		R _L =100Ω Differential	1.125		1.4	Volts
Delta Offset Voltage					50	mV
Pk to Pk Output Swing				350		mV
Output Transition time ² Rise Time Fall Time	t _R t _F	T=25°C 20%/80%		300		ps
Startup Time ³	t _{SU}	T=25°C			10	ms
Output Duty Cycle	SYM		45		55	%
Input Logic Levels Input logic high Input logic low	V _{IH} V _{IL}		0.75*V _{DD} -		- 0.25* V _{DD}	Volts
Output Disable Time	t _{DA}			100		ns
Output Enable Time	t _{EN}			5		us
Enable Pull-Up Resistor ⁴				33		kΩ
Period Jitter				4		ps _{RMS}
Integrated Phase Noise	J _{CC}	12kHz – 20MHz Band 100kHz – 20MHz Band 200kHz – 20MHz Band			<3 <1 <0.7	ps _{RMS}

Notes:

1. Pin 6 (V_{DD}) should filtered with 0.1uF capacitor
2. Output Waveform and Test Circuit figures below define these parameters
3. Output frequency to within 100ppm of final stable output frequency.
4. Output is enabled if pad is floated or not connected

DISCERA, Inc.
Phone: +1 (408) 432-8600

1961 Concourse Drive, Suite E,
Fax: +1 (408) 432-8609

San Jose, California 95131
Email: sales@discera.com

USA
www.discera.com

Output Waveform

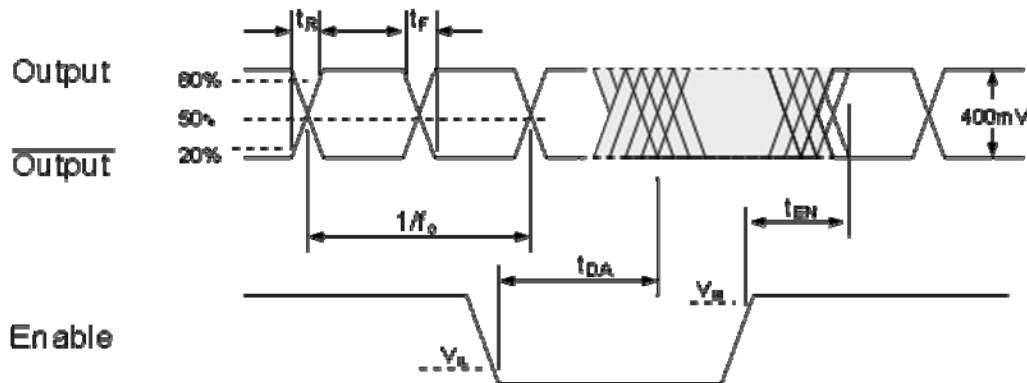

Typical DC Termination Scheme

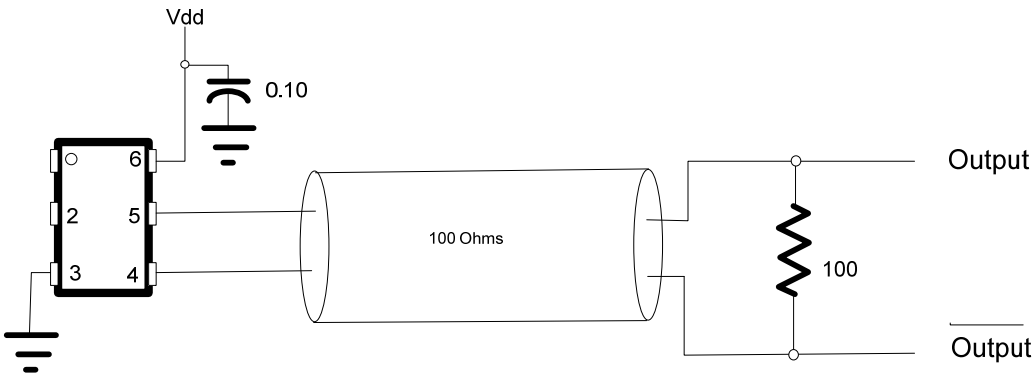

Test Circuit

