

DSCA43



General Purpose Input Signal Conditioners, with DC Excitation

Description

Each DSCA43 general purpose input module provides a single channel of transducer input which is filtered, isolated, amplified, and converted to a high-level voltage output. Signal filtering is accomplished with a five-pole filter which is optimized for step response. An anti-aliasing pole is located on the field side of the isolation barrier, and the other four poles are on the system side. After the initial field-side filtering, the input signal is chopped by a proprietary chopper circuit. Isolation is provided by transformer coupling, again using a proprietary technique to suppress transmission of common mode spikes or surges.

Transducer excitation is provided from the module by a stable 10V source. This source is fully isolated, allowing the amplifier inputs to operate over the full range of the excitation voltage. This feature enables the module to be interfaced to a wide variety of sensors requiring excitation.

Module output is either voltage or current. For current output models a dedicated loop supply is provided at terminal 3 (+OUT) with loop return located at terminal 4 (-OUT). The system-side load may be either floating or grounded.

Special input circuits provide signal input and excitation protection against accidental connection of power-line voltages up to 240VAC and against transient events as defined by ANSI/IEEE C37.90.1. Protection circuits are also present on the signal output and power input terminals to guard against transient events and power reversal. Signal and power lines are secured to the module using screw terminals which are in pluggable terminal blocks for ease of system assembly and reconfiguration.

The modules have excellent stability over time and do not require recalibration, however, zero and span settings are adjustable up to $\pm 5\%$ to accommodate

► Features

- Interfaces to Transducers and Other Devices Requiring a Stable, Isolated DC Supply
- Industry Standard Output of Either 0-10V, $\pm 10V$, 0-20mA, or 4-20mA
- 1500Vrms Transformer Isolation
- ANSI/IEEE C37.90.1 Transient Protection
- Input Protected to 240VAC Continuous
- True 3-Way Isolation
- Wide Range of Supply Voltage
- 100dB CMR
- Fully Isolated Excitation Supply
- $\pm 0.03\%$ Accuracy
- $\pm 0.01\%$ Linearity
- Easily Mounts on Standard DIN Rail
- C-UL-US Listed
- CE and ATEX Compliant

situations where fine-tuning is desired. The adjustments are made using potentiometers located under the front panel label and are non-interactive for ease of use.

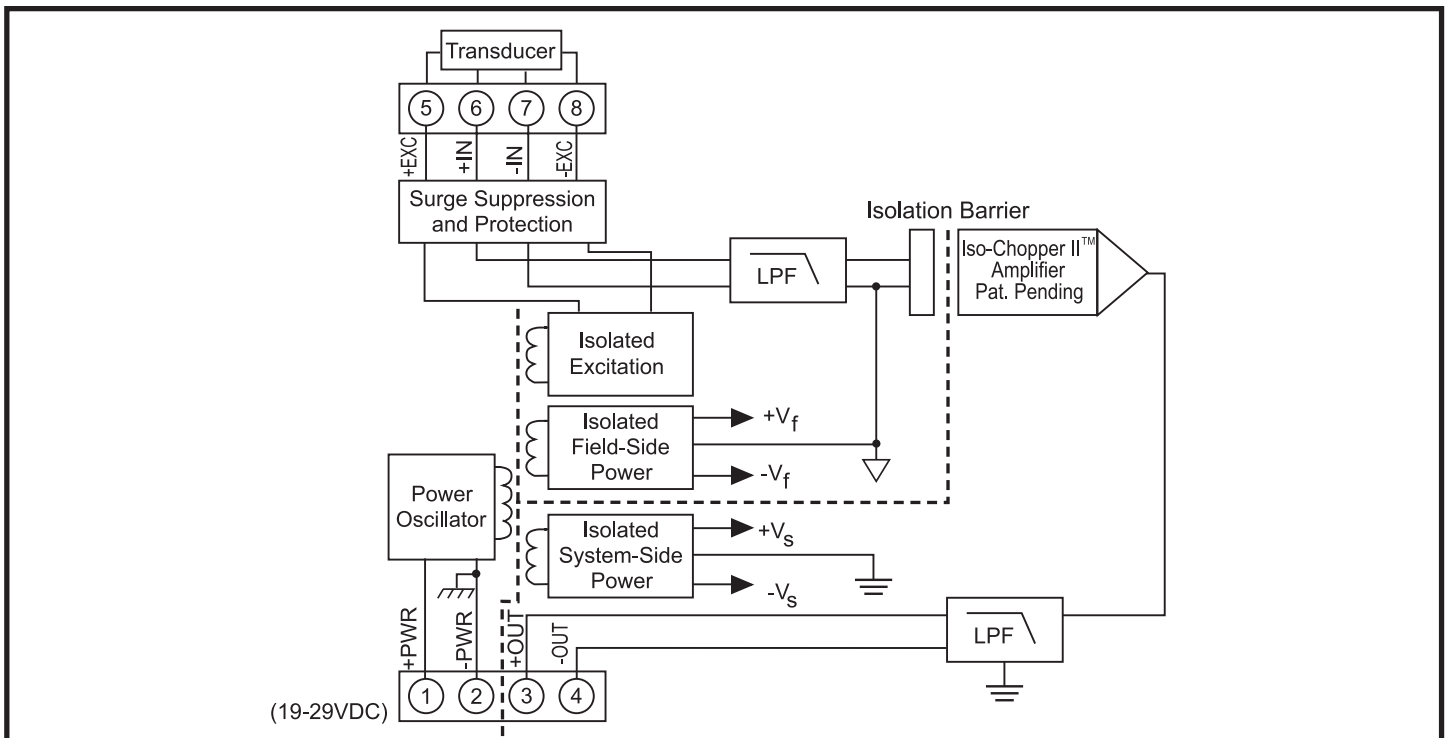

Figure 1: DSCA43 Block Diagram

Specifications Typical at $T_A = +25^\circ\text{C}$ and +24V supply voltage

Module	DSCA43
Input Range	$\pm 1\text{V to } \pm 10\text{V}$
Input Bias Current	$\pm 0.05\text{nA}$
Input Resistance	
Normal	$> 500\text{k}\Omega$
Power Off	$> 500\text{k}\Omega$
Overload	$> 500\text{k}\Omega$
Signal Input Protection	
Continuous	240Vrms max
Transient	ANSI/IEEE C37.90.1
Excitation	
Output Voltage (-EXC to +EXC)	$10\text{V} \pm 0.03\%$
Output Current	40mA maximum
Load Regulation	$\pm 5\text{ppm/mA}$
Stability	$\pm 15\text{ppm}/^\circ\text{C}$
Protection	
Continuous	240Vrms max
Transient	ANSI/IEEE C37.90.1
Output Range	See Ordering Information
Load Resistance (I_{OUT})	600 Ω max
Current Limit	8mA (V_{OUT}), 30mA (I_{OUT})
Output Protection	
Short to Ground	Continuous
Transient	ANSI/IEEE C37.90.1
CMV, Input to Output, Input to Power	
Continuous	1500Vrms max
Transient	ANSI/IEEE C37.90.1
CMV, Output to Power	
Continuous	50VDC max
CMR (50Hz or 60Hz)	100dB
Accuracy ⁽¹⁾	$\pm 0.03\%$ Span
Linearity	$\pm 0.01\%$ Span
Adjustability	$\pm 5\%$ Zero and Span
Stability	
Input Offset	$\pm 5\mu\text{V}/^\circ\text{C}$
Output Offset	$\pm 6\text{ppm}/^\circ\text{C}$ (V_{OUT}), $\pm 20\text{ppm}/^\circ\text{C}$ (I_{OUT})
Gain	$\pm 55\text{ppm}/^\circ\text{C}$
Output Noise, 100kHz Bandwidth	750 μVrms (V_{OUT}), 3 μArms (I_{OUT})
Bandwidth, -3dB	3kHz
NMR	100dB/Decade Above 3kHz
Response Time, 90% Span	170 μs
Power Supply	
Voltage	19 to 29VDC
Current	60mA (V_{OUT}), 80mA (I_{OUT})
Sensitivity	+0.0002%/%
Protection	
Reverse Polarity	Continuous
Transient	ANSI/IEEE C37.90.1
Environmental	
Operating Temperature Range	$-40^\circ\text{C to } +80^\circ\text{C}$
Storage Temperature Range	$-40^\circ\text{C to } +80^\circ\text{C}$
Relative Humidity	0 to 95% Noncondensing
Emissions EN61000-6-4	ISM, Group 1
Radiated, Conducted	Class A
Immunity EN61000-6-2	ISM, Group 1
RF	Performance A $\pm 0.05\%$ Span Error
ESD, EFT	Performance B
Mechanical Dimensions	
(h)(w)(d)	2.95" x 0.89" x 4.13"
Mounting	(75mm x 22.5mm x 105mm) DIN EN 50022 -35x7.5 or -35x15 rail

NOTES:

(1) Includes linearity, hysteresis and repeatability.

Ordering Information

Model	Input Range	Output Range [†]
DSCA43-01	-1V to +1V	1
DSCA43-02	-2V to +2V	1
DSCA43-03	-3V to +3V	1
DSCA43-04	-4V to +4V	1
DSCA43-05	-5V to +5V	1
DSCA43-06	-6V to +6V	1
DSCA43-07	-7V to +7V	1
DSCA43-08	-8V to +8V	1
DSCA43-09	-9V to +9V	1
DSCA43-10	-10V to +10V	1
DSCA43-11	-1V to +1V	2, 3, 4
DSCA43-12	-2V to +2V	2, 3, 4
DSCA43-13	-3V to +3V	2, 3, 4
DSCA43-14	-4V to +4V	2, 3, 4
DSCA43-15	-5V to +5V	2, 3, 4
DSCA43-16	-6V to +6V	2, 3, 4
DSCA43-17	-7V to +7V	2, 3, 4
DSCA43-18	-8V to +8V	2, 3, 4
DSCA43-19	-9V to +9V	2, 3, 4
DSCA43-20	-10V to +10V	2, 3, 4

†Output Ranges Available

Output Range	Part No. Suffix	Example
1. -10V to +10V	NONE	DSCA43-01
2. 0V to +10V	NONE	DSCA43-11
3. 4 to 20mA	C	DSCA43-11C
4. 0 to 20mA	E	DSCA43-11E

Installation Notes:

- 1.) This Equipment is Suitable for Use in Class I, Division 2, Groups A, B, C, D, or Non-Hazardous Locations Only.
- 2.) Warning - Explosion Hazard - Substitution of Components May Impair Suitability for Class I, Division 2.
- 3.) Warning - Explosion Hazard - Do Not Disconnect Equipment Unless Power Has Been Switched Off or The Area is Known to be Non-Hazardous.