

# DSCA32

## Analog Current Input Signal Conditioners



### Description

Each DSCA32 current input module provides a single channel of analog input which is filtered, isolated, amplified, and converted to a high-level voltage output. Signal filtering is accomplished with a five-pole filter which is optimized for step response. An anti-aliasing pole is located on the field side of the isolation barrier, and the other four poles are on the system side. After the initial field-side filtering, the input signal is chopped by a proprietary chopper circuit. Isolation is provided by transformer coupling, again using a proprietary technique to suppress transmission of common mode spikes or surges.

Module output is either voltage or current. For current output models a dedicated loop supply is provided at terminal 3 (+OUT) with loop return located at terminal 4 (-OUT). The system-side load may be either floating or grounded.

Special input circuits provide protection against accidental connection of power-line voltages up to 240VAC and against transient events as defined by ANSI/IEEE C37.90.1. Protection circuits are also present on the signal output and power input terminals to guard against transient events and power reversal. Signal and power lines are secured to the module using screw terminals which are in pluggable terminal blocks for ease of system assembly and reconfiguration.

The modules have excellent stability over time and do not require recalibration, however, zero and span settings are adjustable up to ±5% to accommodate situations where fine-tuning is desired. The adjustments are made using potentiometers located under the front panel label and are non-interactive for ease of use.

### ► Features

- Accepts Milliamp Level Signals
- Industry Standard Output of either 0 to 10V, 0 to 20mA, or 4 to 20mA
- 1500Vrms Transformer Isolation
- ANSI/IEEE C37.90.1 Transient Protection
- Input Protected to 240VAC Continuous
- True 3-Way Isolation
- Wide Range of Supply Voltage
- 105dB CMR
- 5 Poles of Filtering
- ±0.03% Accuracy
- ±0.01% Linearity
- Easily Mounts on Standard DIN Rail
- C-UL-US Listed
- CE and ATEX Compliant

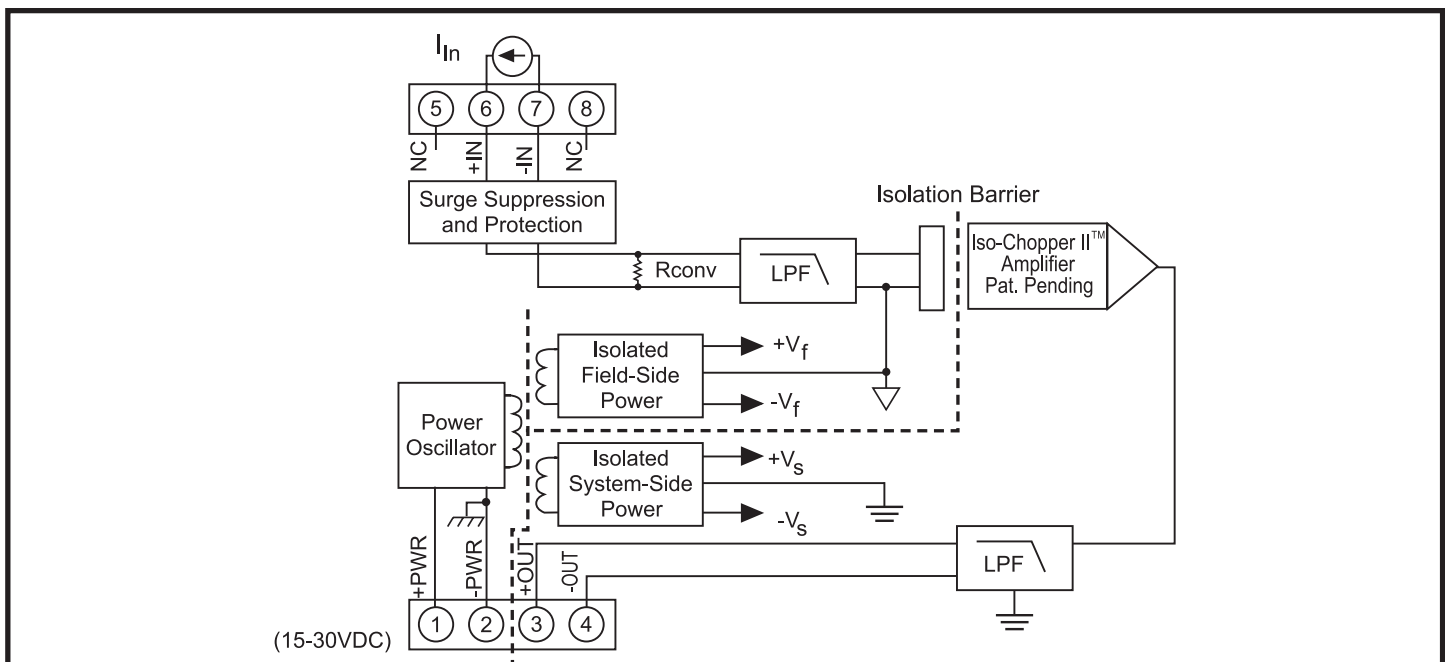

Figure 1: DSCA32 Block Diagram

**Specifications** Typical at  $T_A = +25^\circ\text{C}$  and +24V supply voltage

Module	DSCA32
Input Range	0-20mA or 4-20mA
Input Resistance	
Normal	<100Ω
Power Off	<100Ω
Overload	65kΩ
Input Protection	
Continuous	240Vrms max
Transient	ANSI/IEEE C37.90.1
Output Range	See Ordering Information
Load Resistance ( $I_{OUT}$ )	600Ω max
Current Limit	8mA ( $V_{OUT}$ ), 30mA ( $I_{OUT}$ )
Output Protection	
Short to Ground	Continuous
Transient	ANSI/IEEE C37.90.1
CMV, Input to Output, Input to Power	
Continuous	1500Vrms max
Transient	ANSI/IEEE C37.90.1
CMV, Output to Power	
Continuous	50VDC max
CMR (50Hz or 60Hz)	105dB
Accuracy <sup>(1)</sup>	±0.03% Span
Linearity	±0.01% Span
Adjustability	±5% Zero and Span
Stability	
Offset	±6ppm/°C ( $V_{OUT}$ ), ±20ppm/°C ( $I_{OUT}$ )
Gain	±40ppm/°C
Output Noise, 100kHz Bandwidth	300μVrms ( $V_{OUT}$ ), 1.2μArms ( $I_{OUT}$ )
Bandwidth, -3dB	100Hz
NMR (-3dB at 100Hz)	100dB/decade Above 100Hz
Response Time, 90% Span	5ms
Power Supply	
Voltage	15 to 30VDC
Current	25mA ( $V_{OUT}$ ), 55mA ( $I_{OUT}$ )
Sensitivity	±0.0001%/%
Protection	
Reverse Polarity	Continuous
Transient	ANSI/IEEE C37.90.1
Environmental	
Operating Temperature Range	-40°C to +80°C
Storage Temperature Range	-40°C to +80°C
Relative Humidity	0 to 95% Noncondensing
Emissions EN61000-6-4	ISM, Group 1
Radiated, Conducted	Class A
Immunity EN61000-6-2	ISM, Group 1
RF	Performance A ±0.05% Span Error
ESD, EFT	Performance B
Mechanical Dimensions	
(h)(w)(d)	2.95" x 0.89" x 4.13" (75mm x 22.5mm x 105mm)
Mounting	DIN EN 50022 -35x7.5 or -35x15 rail

**NOTES:**

(1) Includes linearity, hysteresis and repeatability.

**Installation Notes:**

- 1.) This Equipment is Suitable for Use in Class I, Division 2, Groups A, B, C, D, or Non-Hazardous Locations Only.
- 2.) Warning - Explosion Hazard - Substitution of Components May Impair Suitability for Class I, Division 2.
- 3.) Warning - Explosion Hazard - Do Not Disconnect Equipment Unless Power Has Been Switched Off or The Area is Known to be Non-Hazardous.

**Ordering Information**

Model	Input Range	Output Range <sup>†</sup>
DSCA32-01	4mA to 20mA	2, 3, 4
DSCA32-02	0mA to 20mA	2, 3, 4
DSCA32-03	±20mA	1

**†Output Ranges Available**

Output Range	Part No. Suffix	Example
1. -10V to +10V	NONE	DSCA32-03
2. 0V to +10V	NONE	DSCA32-01
3. 4 to 20mA	C	DSCA32-01C
4. 0 to 20mA	E	DSCA32-01E