



**Applications**

- Motor Control
- Overvoltage Crowbar Protection
- Capacitive Discharge Ignition
- Voltage Regulation
- Welding Equipment
- Capacitive Filter Soft Start (Inrush Current Control)

- > Suitable for General Purpose AC Switching
- > IGT 60mA Max.
- > VDRM/VRMM 800, 1000, 1200, 1400, 1600V

**Absolute Maximum Ratings**

|  | CONDITIONS             | SYMBOL              | RATING               |
|--|------------------------|---------------------|----------------------|
| RMS On-State Current (full sine wave) <sup>NOTE 1</sup>  | T <sub>c</sub> = 80°C  | I <sub>T(RMS)</sub> | 70A                  |
| Average On-State Current   | T <sub>c</sub> = 80°C  | I <sub>T(AV)</sub>  | 50A                  |
| Non Repetitive Surge Peak On-State Current (Full Cycle, T <sub>j</sub> Initial = 25°C)                               | F = 50 Hz<br>F = 60 Hz | I <sub>TSM</sub>    | 675A<br>700A         |
| I <sup>2</sup> t Value for fusing  | t <sub>p</sub> = 10 ms | I <sup>2</sup> t    | 4067A <sup>2</sup> s |
| Critical rate of rise of on-state current<br>I <sub>G</sub> =2 x I <sub>GT</sub> , tr<100 ns, T <sub>j</sub> = 125°C |                        | di/dt               | 100A/μs              |
| Peak Gate Current @ T <sub>j</sub> = 125°C   | t <sub>p</sub> = 20 μs | I <sub>GM</sub>     | 4A                   |
| Average Gate Power Dissipation @ T <sub>j</sub> = 125°C  |                        | PG(AV)              | 1W                   |
| Storage Temperature Range  |                        | T <sub>stg</sub>    | -40 to +150°C        |
| Operating Junction Temperature Range   |                        | T <sub>j</sub>      | -40 to +125°C        |
| Maximum Peak Reverse Gate Voltage  |                        | V <sub>RGM</sub>    | 5V                   |

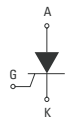

**Electrical Characteristics** <sup>NOTE 2</sup>

|  |                        |          |
|--|------------------------|----------|
| I <sub>GT</sub> MAX @ V <sub>D</sub> = 12 V, R <sub>L</sub> = 30Ω                |                        | 60mA     |
| V <sub>GT</sub> MAX @ V <sub>D</sub> = 12 V, R <sub>L</sub> = 30Ω                |                        | 1.3V     |
| V <sub>GD</sub> MIN @ V <sub>D</sub> = V <sub>DRM</sub> , R <sub>L</sub> = 3.3kΩ | T <sub>j</sub> = 125°C | 0.2V     |
| I <sub>H</sub> MAX @ I <sub>T</sub> = 500 mA (gate open)                         |                        | 180mA    |
| I <sub>L</sub> MAX @ I <sub>G</sub> = 1.2 I <sub>GT</sub>                        |                        | 90mA     |
| dv/dt MIN @ V <sub>D</sub> = 67%V <sub>DRM</sub> (gate open)                     | T <sub>j</sub> = 125°C | 1000V/μs |
| V <sub>TM</sub> MAX @ I <sub>TM</sub> = 150 A, t <sub>p</sub> = 380μs            | T <sub>j</sub> = 25°C  | 1.6V     |
| I <sub>DRM</sub> MAX @ V <sub>DRM</sub> = V <sub>RDM</sub>                       | T <sub>j</sub> = 25°C  | 5μA      |
| I <sub>RDM</sub> MAX @ V <sub>DRM</sub> = V <sub>RDM</sub>                       | T <sub>j</sub> = 125°C | 4mA      |

**GENERAL NOTES**

1. All parameters at 25 degrees C unless otherwise specified.

**ISO9001 Certified**



### Thermal Resistances

|                       |                 | SYMBOL   | RATING  |
|-----------------------|-----------------|----------|---------|
| Junction to Case (AC) | T0-218          | Rth(j-c) | 0.8°C/W |
| Junction to Case (AC) | T0-218 Isolated | Rth(j-c) | 1.1°C/W |
| Junction to Ambient   | T0-218          | Rth(j-a) | 50°C/W  |
| Junction to Ambient   | T0-218 Isolated | Rth(j-a) | 50°C/W  |

### Part Number Selection

| Part Number   | Voltage [Vpk]           | I <sub>GT</sub> [mA] | Package |
|---------------|-------------------------|----------------------|---------|
| CYNA/CYNB-xxx | 800/1000/1200/1400/1600 | 60                   | T0-218  |

### Part Number Designation

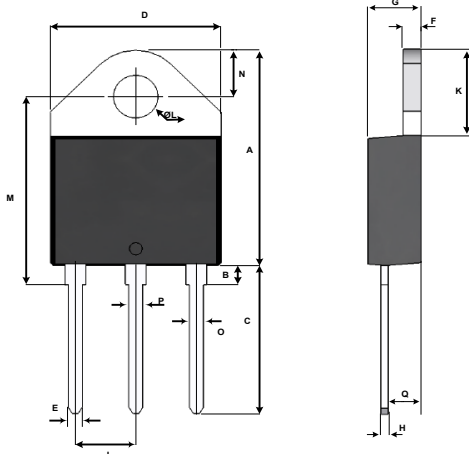
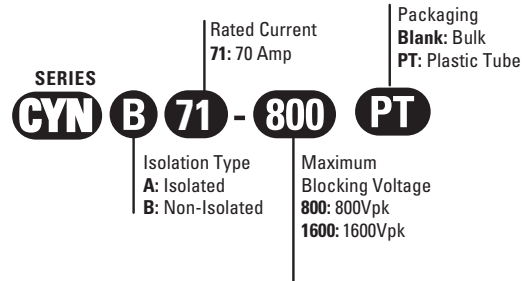

### Dimensions

| REF. | Millimeters |      |       | Inches |       |       |
|------|-------------|------|-------|--------|-------|-------|
|      | Min.        | Typ. | Max.  | Min.   | Typ.  | Max.  |
| A    | 20.4        | 21.1 |       | 0.8    |       | 0.831 |
| B    |             | 3.23 |       |        | 0.127 |       |
| C    | 14.35       |      | 15.60 | 0.565  |       | 0.614 |
| D    | 15.1        |      | 15.5  | 0.594  |       | 0.610 |
| E    | 1.20        |      | 1.40  | 0.047  |       | 0.055 |
| F    | 1.45        |      | 1.55  | 0.057  |       | 0.061 |
| G    | 4.4         |      | 4.6   | 0.173  |       | 0.181 |
| H    | 0.5         |      | 0.7   | 0.020  |       | 0.028 |
| J    | 5.4         |      | 5.65  | 0.213  |       | 0.222 |
| K    | 8.0         |      | 8.25  | 0.315  |       | 0.325 |
| L    | 4.08        |      | 4.17  | 0.161  |       | 0.164 |
| M    | 15.8        |      | 16.5  | 0.622  |       | 0.650 |
| N    | 4.6         |      | 4.8   | 0.181  |       | 0.189 |
| O    | 1.20        |      | 1.40  | 0.047  |       | 0.055 |
| P    | 1.20        |      | 1.40  | 0.047  |       | 0.055 |
| Q    | 2.7         |      | 2.9   | 0.106  |       | 0.114 |

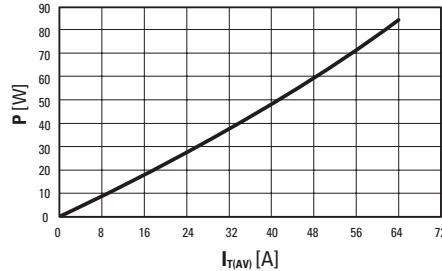

Fig. 1: Power dissipation versus average on-state current.

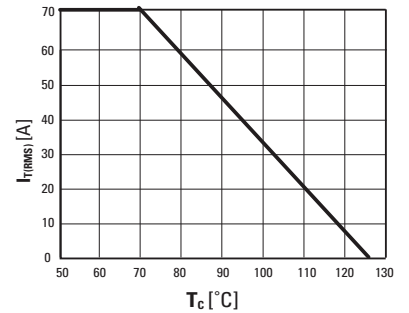

Fig. 2: RMS on-state current versus case temperature (full cycle)

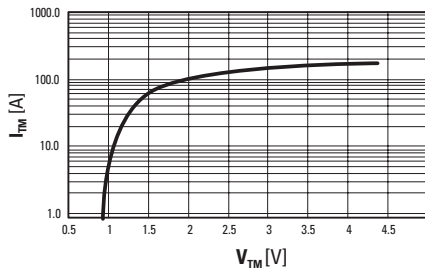

Fig. 3: On-state current versus on-state voltage (instantaneous values)

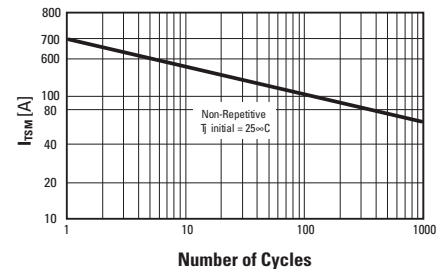

Fig. 4: Non-repetitive surge peak on-state current versus number of cycles.