



### POWER SUPPLY

- AC 100-120 / 200-240V Auto Select Input
- Efficiency up to 91.6%
- Width only 60mm
- 20% Output Power Reserves
- Full Output Power Between -25°C and +60°C
- Minimal Inrush Current Surge
- 3 Year Warranty

## 1. GENERAL DESCRIPTION

The Dimension C-Series are cost optimized power supplies without compromising quality, reliability and performance. The C-Series is part of the Dimension power supply family, existing alongside the high featured Q-series.

The C series includes all the essential basic functions and the devices have a power reserve of 20%. This extra current may even be used continuously at temperatures up to +45°C. The most important features are the small size, the high efficiency and the wide temperature range.

The Auto-select input makes worldwide installation and usage very simple. Defects or system failures caused by wrongly set switches can not occur.

#### C-Series

Related products

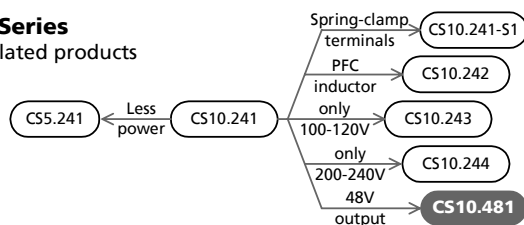

## 2. SHORT-FORM DATA

Output voltage	DC 48V	
Adjustment range	48 - 52V	
Output current	5.0 – 4.6A	ambient <60°C
	6.0 – 5.5A	ambient <45°C
Output power	240W	ambient <60°C
	288W	ambient <45°C
Output ripple	< 100mVpp	20Hz to 20MHz
Input voltage	AC 100-120 / 200-240V	Auto-select Input
Mains frequency	50-60Hz	±6%
AC Input current	typ. 3.73 / 2.23A	at 120 / 230Vac
Power factor	typ. 0.59 / 0.51	at 120 / 230Vac
AC Inrush current	typ. 3A peak	
DC Input	not allowed	
Efficiency	typ. 91.0 / 91.6%	at 120 / 230Vac
Losses	typ. 23.7 / 22.0W	at 120 / 230Vac
Temperature range	-25°C to +70°C	operational
Derating	6W/°C	+60 to +70°C
Hold-up time	typ. 46 / 47ms	at 120 / 230Vac
Dimensions	60x124x117mm	WxHxD

## 3. ORDER NUMBERS

Power Supply **CS10.481** Standard unit, 48Vdc

Accessory      ZM1.WALL      Wall mount bracket  
                     ZM13.SIDE      Side mount bracket  
                     YRM2.DIODE      Redundancy module

## 4. MARKINGS



Marine, pending



INDEX	PAGE	INDEX	PAGE
1. General Description .....	1	20. Fulfilled Standards.....	13
2. Short-form Data .....	1	21. Used Substances .....	13
3. Order Numbers.....	1	22. Physical Dimensions and Weight.....	14
4. Markings.....	1	23. Installation and Operation Instructions .....	14
5. AC-Input.....	3	24. Accessory.....	15
6. Input Inrush Current Surge .....	4	25. Application Notes.....	16
7. Hold-up Time.....	4	25.1. Peak Current Capability .....	16
8. Output .....	5	25.2. Charging of Batteries.....	16
9. Efficiency and Power Losses.....	6	25.3. Back-feeding Loads .....	17
10. Functional Diagram.....	7	25.4. Output Circuit Breakers .....	17
11. Reliability.....	7	25.5. Inductive and Capacitive Loads .....	18
12. Front Side and User Elements.....	8	25.6. Series Operation.....	18
13. Terminals and Wiring.....	8	25.7. Parallel Use to Increase Output Power .	18
14. EMC.....	9	25.8. Parallel Use for 1+1 Redundancy.....	18
15. Environment.....	11	25.9. External Input Protection.....	19
16. Protection Features .....	11	25.10. Operation on Two Phases.....	19
17. Safety .....	12	25.11. Use in a Tightly Sealed Enclosure .....	19
18. Dielectric Strength .....	12	25.12. Mounting Orientations.....	20
19. Approvals.....	13		

### INTENDED USE

The power supply shall only be installed and put into operation by qualified personnel.  
 This power supply is designed for installation in an enclosure and is intended for the general use, such as in industrial control, office, communication, and instrumentation equipment. Do not use this device in aircraft, trains and nuclear equipment, where malfunctioning of the power supply may cause severe personal injury or threaten human life.

### TERMINOLOGY AND ABBREVIATIONS

<b>PE and <math>\oplus</math> symbol</b>	PE is the abbreviation for <b>Protective Earth</b> and has the same meaning as the symbol $\oplus$ .
<b>Earth, Ground</b>	This document uses the term "earth" which is the same as the U.S. term "ground".
<b>T.b.d.</b>	To be defined, value or description will follow later.
<b>AC 230V</b>	A figure displayed with the AC or DC before the value represents a nominal voltage with standard tolerances (usually $\pm 20\%$ ) included. E.g.: DC 12V describes a 12V battery disregarding whether it is full (13.7V) or flat (10V) As long as not otherwise stated, AC 100V and AC 230V parameters are valid at 50Hz and AC 120V parameters are valid at 60Hz mains frequency.
<b>230Vac</b>	A figure with the unit (Vac) at the end is a momentary figure without any additional tolerances included.

### DISCLAIMER

The information presented in this document is believed to be accurate and reliable and may change without notice.

### 5. AC-INPUT

AC input	nom.	AC 100-120V / 200-240V	auto-select input, TN-, TT-, IT-Mains, see Fig. 5-1
AC input range		90-132Vac 180-264Vac 85-90Vac 264-300Vac	100-120V range, continuous operation 200-240V range, continuous operation Short term or with output derating < 0.5s
Input frequency	nom.	50 – 60Hz	±6%

		AC 100V	AC 120V	AC 230V	
Input current	typ.	4.34A	3.73A	2.23A	at 48V, 5A see Fig. 5-3
Power factor *)	typ.	0.61	0.59	0.51	at 48V, 5A see Fig. 5-1
Crest factor **)	typ.	2,61	2,83	3,3	at 48V, 5A
Start-up delay	typ.	700ms	800ms	850ms	see Fig. 5-2
Rise time	typ.	23ms	23ms	23ms	0mF, 48V, 5A, see Fig. 5-2
	typ.	61ms	61ms	61ms	5mF, 48V, 5A, see Fig. 5-2
Turn-on overshoot	max.	100mV	100mV	100mV	see Fig. 5-2
Turn-on voltage	typ.	80Vac	80Vac	N / A	steady-state value, see Fig. 5-1
Shut-down voltage	typ.	75Vac	75Vac	N / A	steady-state value, see Fig. 5-1

\*) The power factor is the ratio of the true (or real) power to the apparent power in an AC circuit.

\*\*\*) The crest factor is the mathematical ratio of the peak value to the RMS value of the input current waveform

Fig. 5-1 **Input voltage range**

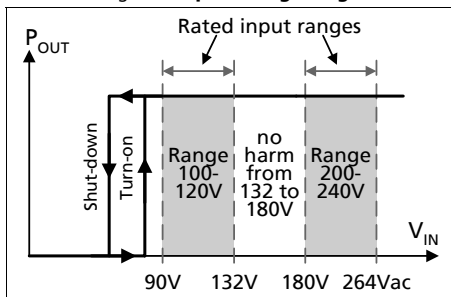

Fig. 5-2 **Turn-on behavior, definitions**

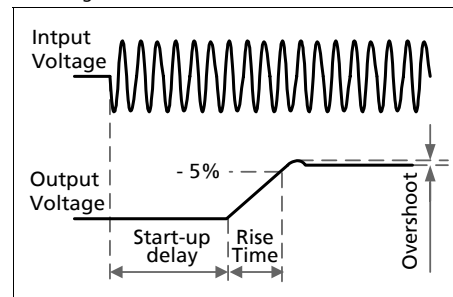

Fig. 5-3 **Input current vs. output load**

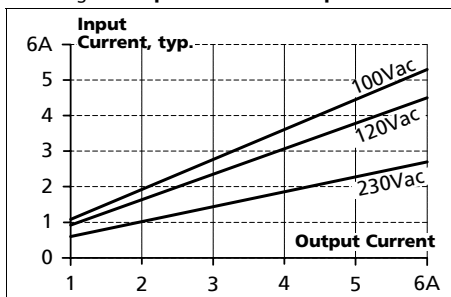
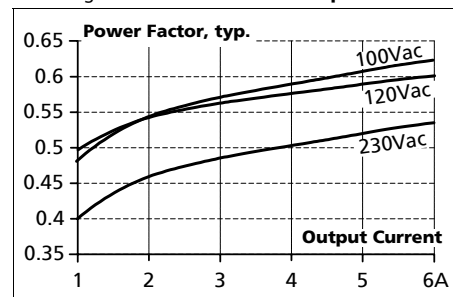

Fig. 5-4 **Power Factor vs. output load**



### 6. INPUT INRUSH CURRENT SURGE

An active inrush limitation circuitry limits the input inrush current after turn-on of the input voltage. The charging current into EMI suppression capacitors is disregarded in the first milliseconds after switch-on.

		AC 100V	AC 120V	AC 230V	
Inrush current	max.	10A <sub>peak</sub>	10A <sub>peak</sub>	10A <sub>peak</sub>	-25°C to +70°C
	typ.	3A <sub>peak</sub>	3A <sub>peak</sub>	3A <sub>peak</sub>	-25°C to +70°C
Inrush energy	typ.	1A <sup>2</sup> s	1A <sup>2</sup> s	1A <sup>2</sup> s	-25°C to +70°C

Fig. 6-1 Input inrush current, typical behavior

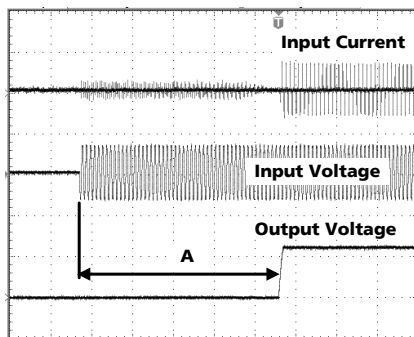

**A:** Start-up delay = Inrush delay  
 Input: 230Vac  
 Output: 48V, 5A  
 Ambient: 25°C  
 Upper curve: Input current 10A / DIV  
 Medium curve: Input voltage 500V / DIV  
 Lower curve: Output voltage 40V / DIV  
 Time scale: 100ms / DIV

### 7. HOLD-UP TIME

		AC 100V	AC 120V	AC 230V	
Hold-up Time	typ.	62ms	107ms	103ms	2.5A, 48V, see Fig. 7-1
	typ.	23ms	46ms	47ms	5A, 48V, see Fig. 7-1
	typ.	17ms	35ms	37ms	6A, 48V, see Fig. 7-1

Fig. 7-1 Hold-up time vs. input voltage

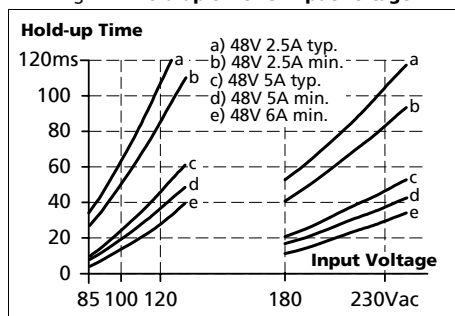
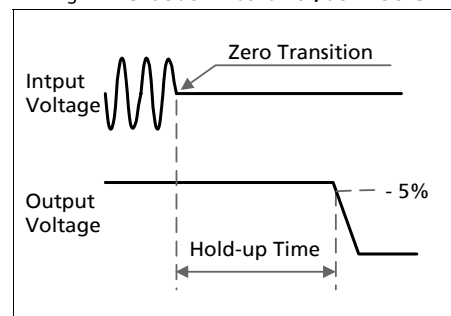

Fig. 7-2 Shut-down behavior, definitions



Note: At no load, the hold-up time can be up to several seconds. The green DC-ok lamp is on during this time.

### 8. OUTPUT

Output voltage	nom.	48V	
Adjustment range	min.	48-52V	guaranteed
	max.	60V	at clockwise end position of potentiometer
Factory setting		48.0V	±0.2%, at full load, cold unit
Line regulation	max.	70mV	90 to 132Vac or 180 to 264Vac
Load regulation	max.	100mV	static value, 0A → 10A → 0A
Ripple and noise voltage	max.	100mVpp	20Hz to 20MHz, 50Ohm
Output capacitance	typ.	3 100µF	
Output current	nom.	6A	at 48V, ambient < 45°C, see Fig. 8-1
	nom.	5A	at 48V, ambient < 60°C, see Fig. 8-1
	nom.	5.5A	at 52V, ambient < 45°C, see Fig. 8-1
	nom.	4.6A	at 52V, ambient < 60°C, see Fig. 8-1
Output power	nom.	288W	ambient < 45°C
	nom.	240W	ambient < 60°C
Short-circuit current	min.	7A	load impedance 100mOhm, see Fig. 8-1
	max.	9A	load impedance 100mOhm, see Fig. 8-1

Fig. 8-1 Output voltage vs. output current, typ.

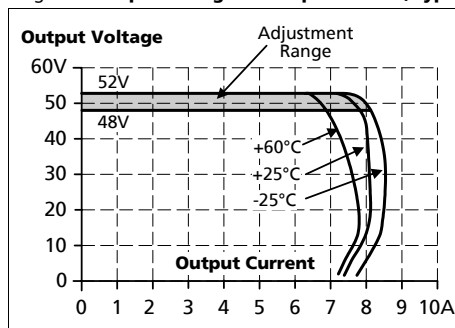

#### Peak current capability (up to several ms)

The power supply can deliver a peak current which is higher than the specified short term current. This helps to start current demanding loads or to safely operate subsequent circuit breakers.

The extra current is supplied by the output capacitors inside the power supply. During this event, the capacitors will be discharged and causes a voltage dip on the output. Detailed curves can be found in chapter 25.1.

Peak current voltage dips	typ.	from 48V to 38 V	at 10A for 50ms, resistive load
	typ.	from 48V to 35V	at 25A for 2ms, resistive load
	typ.	from 48V to 28V	at 25A for 5ms, resistive load

### 9. EFFICIENCY AND POWER LOSSES

		AC 100V	AC 120V	AC 230V	
Efficiency	typ.	90.7%	91.0%	91.6%	5A, 48V
Power losses	typ.	5.8W	8.4W	7.5W	0A
	typ.	12.0W	12.3W	11.3W	2.5A, 48V
	typ.	25.1W	24.1W	22.4W	5A, 48V
	typ.	31.9W	29.6W	27.9W	6A, 48V

Fig. 9-1 Efficiency vs. output current at 48V

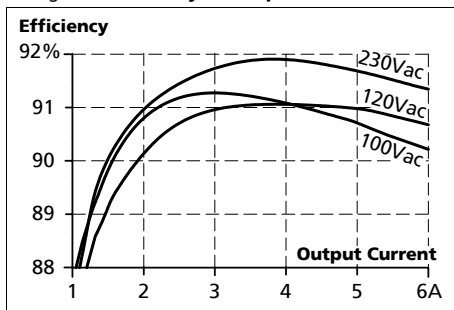

Fig. 9-2 Losses vs. output current at 48V

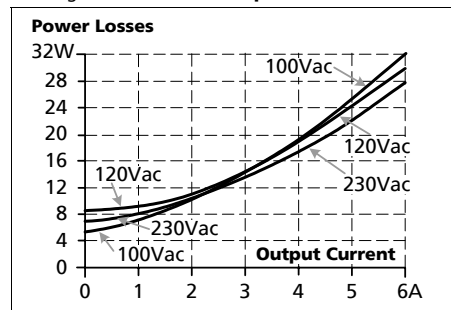

Fig. 9-3 Efficiency vs. input voltage, 48V, 5A

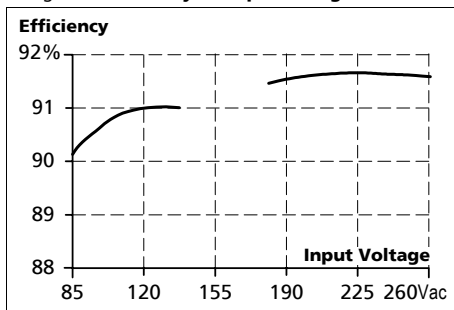
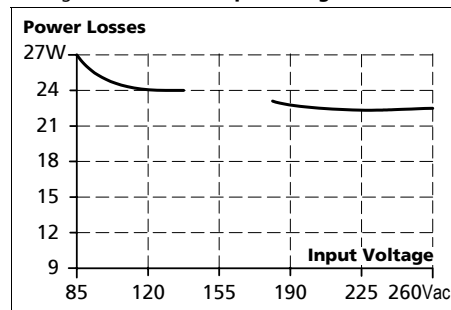
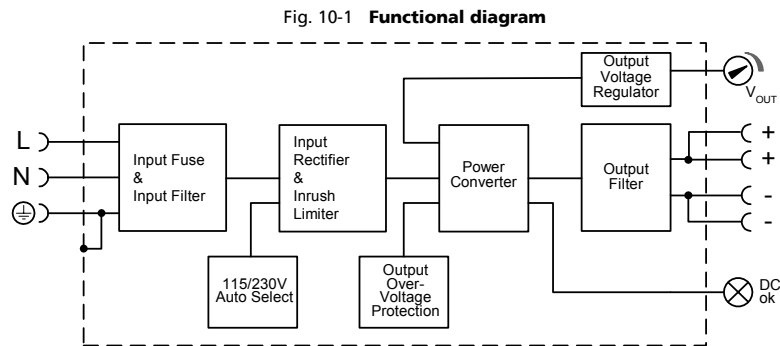

Fig. 9-4 Losses vs. input voltage, 48V, 5A



### 10. FUNCTIONAL DIAGRAM



### 11. RELIABILITY

		AC 100V	AC 120V	AC 230V	
Lifetime expectancy	min.	45 000h	60 000h	96 000h	40°C, 48V, 5A
	min.	33 000h	42 000h	63 000h	40°C, 48V, 6A
	min.	97 000h	106 000h	122 000h	40°C, 48V, 2.5A
	min.	126 000h	15 years	15 years	25°C, 48V, 5A
MTBF SN 29500, IEC 61709		627 000h	653 000h	830 000h	40°C, 48V, 5A
		536 000h	558 000h	709 000h	40°C, 48V, 6A
		1 060 000h	1 104 000h	1 403 000h	25°C, 48V, 5A
MTBF MIL HDBK 217F		459 000h	450 000h	475 000h	40°C, 48V, 5A, Ground Benign GB40
		413 000h	406 000h	426 000h	40°C, 48V, 6A, Ground Benign GB40
		655 000h	642 000h	659 000h	25°C, 48V, 5A, Ground Benign GB25

The **Lifetime expectancy** shown in the table indicates the operating hours (service life) and is determined by the lifetime expectancy of the built-in electrolytic capacitors.

Lifetime expectancy is specified in operational hours. Lifetime expectancy is calculated according to the capacitor's manufacturer specification. The prediction model allows a calculation of up to 15 years from date of shipment.

**MTBF** stands for **Mean Time Between Failure**, which is calculated according to statistical device failures, and indicates reliability of a device. It is the statistical representation of the likelihood of a unit to fail and does not necessarily represent the life of a product.

## 12. FRONT SIDE AND USER ELEMENTS

Fig. 12-1 Front side

### Output Terminals

Screw terminals

- + Positive output
  - Negative (return) output
- Dual pins per pole

### Output voltage potentiometer

Open the flap to tune the output voltage.  
Factory set: 48.0V

### DC-on lamp (green)

On when the voltage on the output terminals is > 37V

### Input Terminals

Screw terminals

- N ... Neutral input
- L ... Line (hot) input
- ⊕ ... PE (Protective Earth) input



## 13. TERMINALS AND WIRING

Type	Screw terminals
Solid wire	0.5-6mm <sup>2</sup>
Stranded wire	0.5-4mm <sup>2</sup>
American wire gauge	20-10 AWG
Ferrules	allowed, but not required
Wire stripping length	7mm / 0.275inch
Screwdriver	3.5mm slotted or Pozidrive No 2
Recommended tightening torque	0.8Nm, 7lb.in

### Instructions:

- a) Use appropriate copper cables that are designed for an operating temperature of:  
60°C for ambient up to 45°C and  
75°C for ambient up to 60°C minimum.
- b) Follow national installation codes and installation regulations!
- c) Ensure that all strands of a stranded wire enter the terminal connection!
- d) Up to two stranded wires with the same cross section are permitted in one connection point (except PE wire).
- e) Do not use the unit without PE connection.



### 14. EMC

The CE mark is in conformance with EMC guideline 89/336/EEC and 93/68/EEC and the low-voltage directive (LVD) 73/23/EWG. A detailed EMC Report is available on request.

<b>EMC Immunity</b>	EN 61000-6-2, EN 61000-6-1	Generic standards		
Electrostatic discharge	EN 61000-4-2	Contact discharge	8kV	Criterion A
		Air discharge	15kV	Criterion A
Electromagnetic RF field	EN 61000-4-3	80MHz-1GHz	10V/m	Criterion A
Fast transients (Burst)	EN 61000-4-4	Input lines	4kV	Criterion A
		Output lines	2kV	Criterion A
Surge voltage on input	EN 61000-4-5	L → N	2kV	Criterion A
		N / L → PE	4kV	Criterion A
Surge voltage on output	EN 61000-4-5	+ → -	500V	Criterion A
		+ / - → PE	500V	Criterion A
Conducted disturbance	EN 61000-4-6	0,15-80MHz	10V	Criterion A
Mains voltage dips	EN 61000-4-11	0% of 100Vac	0Vac, 20ms	Criterion A
		40% of 100Vac	40Vac, 200ms	Criterion C
		70% of 100Vac	70Vac, 500ms	Criterion C
		0% of 200Vac	0Vac, 20ms	Criterion A
		40% of 200Vac	80Vac, 200ms	Criterion C
		70% of 200Vac	140Vac, 500ms	Criterion C
Voltage interruptions	EN 61000-4-11		0Vac, 5000ms	Criterion C
Input voltage swells	PULS internal standard		300Vac, 500ms	Criterion A
Powerful transients	VDE 0160	over entire load range	750V, 1.3ms	Criterion A

**Criteria:**

**A:** Power supply shows normal operation behavior within the defined limits.

**C:** Temporary loss of function is possible. Power supply might shut-down and restarts by itself. No damages or hazards for the power supply occur.

<b>Switching frequency</b>	85kHz to 110kHz	input voltage dependent
----------------------------	-----------------	-------------------------

EMC Emission	EN 61000-6-4	Generic standards
Conducted emission	EN 55011, EN 55022, FCC Part 15, CISPR 11, CISPR 22 EN 55022	Class B, input lines Class A, output lines
Radiated emission	EN 55011, EN 55022	Class B
Harmonic input current	EN 61000-3-2	not fulfilled
Voltage fluctuations, flicker	EN 61000-3-3	fulfilled

This device complies with FCC Part 15 rules.

Operation is subjected to following two conditions: (1) this device may not cause harmful interference, and (2) this device must accept any interference received, including interference that may cause undesired operation.

The power supply does not fulfill the harmonic current standard EN61000-3-2.

Please note:

**A power supply has to comply with EN 61000-3-2 (Standard for harmonic input current) when:**

- 1) the end-device is used within the European Union **and**
- 2) the end-device is connected to a public mains supply with a nominal voltage  $\geq 220\text{Vac}$  **and**
- 3) the power supply is:
  - fitted in an end-device with an average input power in excess of 75W **or**
  - fitted in an end-device with a continuous input power in excess of 75W **or**
  - part of a lighting system.

**Exceptions:**

End-devices for professional applications with an input power  $> 1000\text{W}$  do not need to fulfill EN 61000-3-2.

**Comments:**

- The average input power must be determined in accordance with EN 61000-3-2.
- Industrial mains supplies with their own transformer are considered to be "non-public".
- Where individual self-contained items of equipment are installed in a rack or case (e.g. devices connected in parallel), they are regarded as being individually connected to the mains supply. The rack or case need not be tested as a whole. Alternatively it is also permitted to assess the whole rack or case. This is recommended for devices used in professional applications with an input power greater than 1000W.

### 15. ENVIRONMENT

Operational temperature	-25°C to +70°C (-13°F to 158°F)	reduce output power according <b>Fig. 15-1</b>
Output de-rating	3.2W/°C 6W/°C	45-60°C (113°F to 140°F) 60-70°C (140°F to 158°F)
Storage temperature	-40 to +85°C (-40°F to 185°F)	storage and transportation
Humidity	5 to 95% r.H.	IEC 60068-2-30 Do not energize while condensation is present
Vibration sinusoidal	2-17.8Hz: ±1.6mm; 17.8-500Hz: 2g 2 hours / axis	IEC 60068-2-6
Shock	30g 6ms, 20g 11ms 3 bumps / direction, 18 bumps in total	IEC 60068-2-27
Altitude	0 to 6000m (0 to 20 000ft)	Reduce output power or ambient temperature above 2000m sea level.
Output de-rating (for altitude)	15W/1000m or 5°C/1000m	above 2000m (6500ft), see <b>Fig. 15-2</b>
Over-voltage category	III	EN 50178, altitudes up to 2000m
	II	Altitudes from 2000m to 6000m
Degree of pollution	2	EN 50178, not conductive

Fig. 15-1 **Output current vs. ambient temp.,**

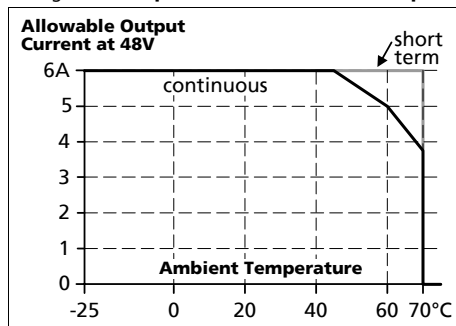

The ambient temperature is defined 2cm below the unit.

Fig. 15-2 **Output current vs. altitude**

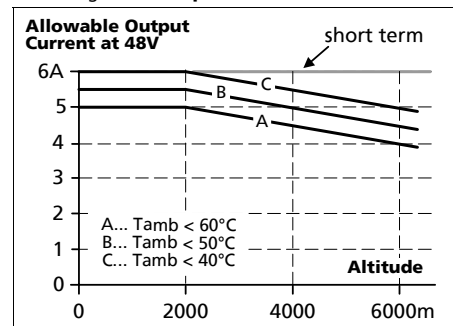

### 16. PROTECTION FEATURES

Output protection	Electronically protected against overload, no-load and short-circuits	
Output over-voltage protection	typ. 56Vdc max. 60Vdc	In case of an internal power supply defect, a redundant circuitry limits the maximum output voltage. The output shuts down and automatically attempts to restart.
Output over-current protection	electronically limited	see <b>Fig. 8-1</b>
Degree of protection	IP 20	EN/IEC 60529
Penetration protection	> 3.5mm	e.g. screws, small parts
Over-temperature protection	yes	output shut-down with automatic restart
Input transient protection	MOV	Metal Oxide Varistor
Internal input fuse	T6.3A H.B.C.	not user replaceable

Note: In case of a protection event, audible noise may occur.

Nov. 2006 / Rev.1.1 DS-CS10.481-EN  
All parameters are specified at 48V, 5A, 230Vac, 25°C ambient and after a 5 minutes run-in time unless otherwise noted.

### 17. SAFETY

Input / output separation	SELV PELV double or reinforced insulation	IEC/EN 60950-1 EN 60204-1, EN 50178, IEC 60364-4-41
Class of protection	I	PE (Protective Earth) connection required
Isolation resistance	> 5MΩ	input to output, 500Vdc
PE resistance	< 0.1Ω	between housing and PE terminal
Touch current (leakage current)	typ. 0.36mA typ. 0.50mA typ. 0.64mA < 0.45mA < 0.62mA < 0.85mA	100Vac, 50Hz, TN mains 120Vac, 60Hz, TN mains 230Vac, 50Hz, TN mains 110Vac, 50Hz, TN mains 132Vac, 60Hz, TN mains 264Vac, 50Hz, TN mains

### 18. DIELECTRIC STRENGTH

Fig. 18-1 Dielectric strength

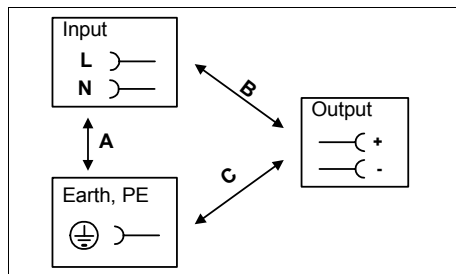

		A	B	C
Type test	60s	2500Vac	3000Vac	500Vac
Factory test	5s	2500Vac	2500Vac	500Vac
Field test	5s	2000Vac	2000Vac	500Vac

**Type tests and factory tests:**

Conducted by the manufacturer. Do not repeat test in field!



**Rules for field test:**

Use appropriate test equipment which applies the voltage with a slow ramp! Connect L and N together as well as all output poles.

The output voltage is floating and has no ohmic connection to ground.

To fulfill the PELV requirements according to EN60204-1 § 6.4.1, we recommend that either the + pole, the - pole or any other part of the output circuit shall be connected to the protective earth system. This helps to avoid situations in which a load starts unexpectedly or can not be switched off any more when unnoticed earth faults occur.

### 19. APPROVALS

IEC 60950-1	<b>IECEE</b> <b>CB SCHEME</b>	CB Scheme, Information Technology Equipment
UL 508	 18WM LISTED IND. CONT. EQ.	LISTED as Industrial Control Equipment E198865
UL 60950-1	 <b>US</b>	RECOGNIZED E137006 recognized for the use in U.S.A. (UL 60950-1) and Canada (C22.2 No. 60950) Information Technology Equipment, Level 5
Marine pending	 <b>ABS</b>	GL (Germanischer Lloyd) classified and ABS (American Bureau for Shipping) PDA for marine and offshore applications. Environmental category: C, EMC2

### 20. FULFILLED STANDARDS

EN 61558-2-17	Safety of Power Transformers
EN/IEC 60204-1	Safety of Electrical Equipment of Machines
EN/IEC 61131-2	Programmable Controllers
EN 50178	Electronic Equipment in Power Installations

### 21. USED SUBSTANCES

The unit does not release any silicone and is suitable for the use in paint shops.

Electrolytic capacitors included in this unit do not use electrolytes such as Quaternary Ammonium Salt Systems.

Plastic housings and other molded plastic materials are free of halogens, wires and cables are not PVC insulated.

The production material within our production does not include following toxic chemicals:

Polychlorized Biphenyl (PCB), Polychlorized Terphenyl (PCB), Pentachlorophenol (PCP), Polychlorinated naphthalene (PCN), Polybrom Biphenyl (PBB), Polybrom Bipheny-oxyd (PBO), Polybrominated Diphenylether (PBDE), Polychlorinated Diphenylether (PCDE), Polydibromophenyl Oxid (PBDO), Cadmium, Asbest, Mercury, Silicia

## 22. PHYSICAL DIMENSIONS AND WEIGHT

Weight	700g / 1.54lb
DIN-Rail	Use 35mm DIN-rails according to EN 60715 or EN 50022 with a height of 7.5 or 15mm. The DIN-rail height must be added to the depth (117mm) to calculate the total required installation depth.

Electronic files with mechanical data can be downloaded at [www.pulspower.com](http://www.pulspower.com)

Fig. 22-1 **Front view**

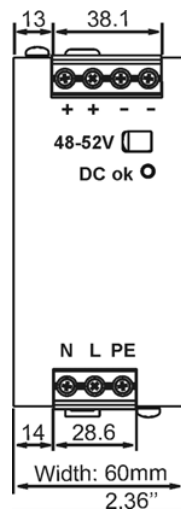
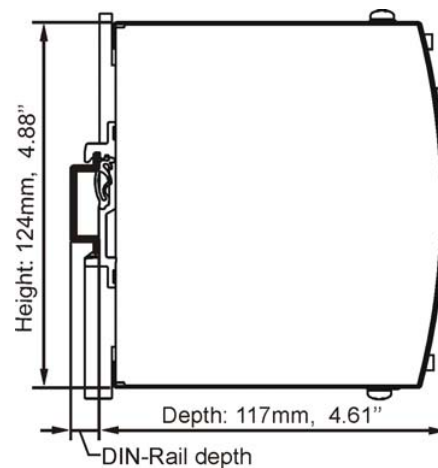

Fig. 22-2 **Side view**



## 23. INSTALLATION AND OPERATION INSTRUCTIONS

### Mounting Orientation:

Output terminal must be located on top and input terminal on the bottom. For other orientations see section 25.12.

### Cooling:

Convection cooled, no forced cooling required. Do not cover ventilation grid (e.g. cable conduit) by more than 30%!

### Installation clearances:

40mm on top, 20mm on the bottom, 5mm on the left and right side are recommended when loaded permanently with full power. In case the adjacent device is a heat source, 15mm clearance are recommended.

### Risk of electrical shock, fire, personal injury or death!

Do not use the unit without proper earth connection (Protective Earth). Use the pin on the terminal block for earth connection and not one of the screws on the housing.

Turn power off before working on the power supply. Protect against inadvertent re-powering.

Make sure the wiring is correct by following all local and national codes.

Do not open, modify or repair the unit.

Use caution to prevent any foreign objects from entering into the housing.

Do not use in wet locations or in areas where moisture or condensation can be expected.

### Service parts:

The unit does not contain any service parts. The tripping of an internal fuse is caused by an internal defect. If damage or malfunctioning should occur during operation, immediately turn power off and send unit to factory for inspection!

### 24. ACCESSORY

#### ZM1.WALL Wall mounting bracket

This bracket is used to mount Dimension units onto a flat surface without utilizing a DIN-Rail. The two aluminum brackets and the black plastic slider of the unit have to be detached, so that the two steel brackets can be mounted.

Fig. 24-1 ZM1.WALL Wall Mounting Bracket

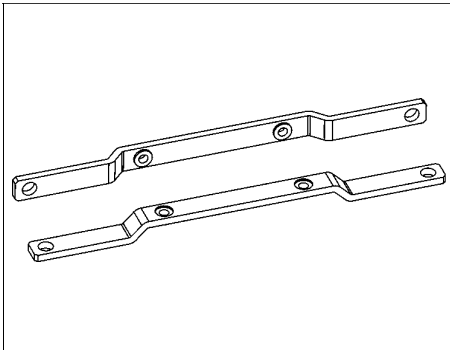
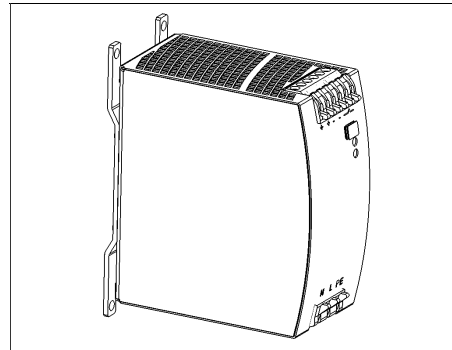

Fig. 24-2 Assembled Wall Mounting Bracket



#### ZM13.SIDE Side mounting bracket

This bracket is used to mount Dimension units sideways with or without utilizing a DIN-Rail. The two aluminum brackets and the black plastic slider of the unit have to be detached, so that the steel brackets can be mounted.

For sideways DIN-rail mounting, the removed aluminum brackets and the black plastic slider need to be mounted on the steel bracket.

Fig. 24-3 ZM13.SIDE Side Mounting Bracket

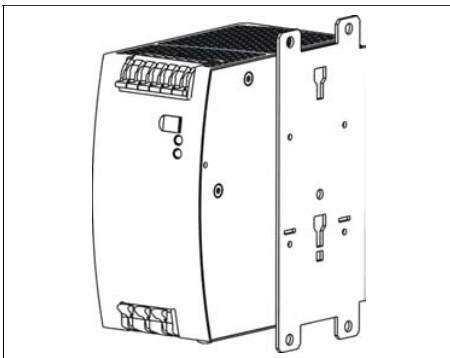
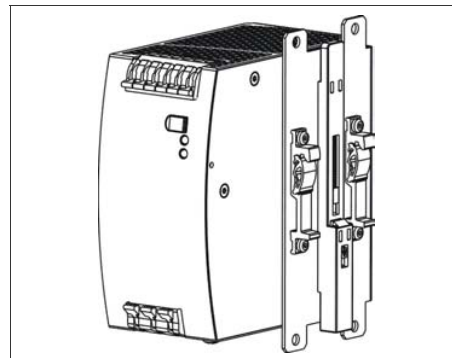

Fig. 24-4 Side Mounting with DIN-rail brackets



## 25. APPLICATION NOTES

### 25.1. PEAK CURRENT CAPABILITY

Solenoids, contactors and pneumatic modules often have a steady state coil and a pick-up coil. The inrush current demand of the pick-up coil is several times higher than the steady state current and usually exceeds the nominal output current (including the PowerBoost). The same situation applies, when starting a capacitive load.

Branch circuits are often protected with circuit breakers or fuses. In case of a short or an overload in the branch circuit, the fuse needs a certain amount of over-current to trip or to blow. The peak current capability ensures the safe operation of subsequent circuit breakers.

Assuming the input voltage is turned on before such an event, the built-in large sized output capacitors inside the power supply can deliver extra current. Discharging this capacitor causes a voltage dip on the output. The following two examples show typical voltage dips:

Fig. 25-1 Peak load 10A for 50ms, typ.

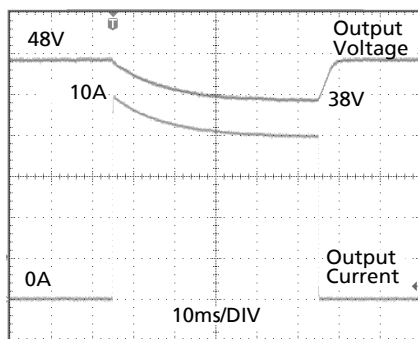

Peak load 10A (resistive) for 50ms  
Output voltage dips from 48V to 38V.

Fig. 25-2 Peak load 25A for 5ms, typ.

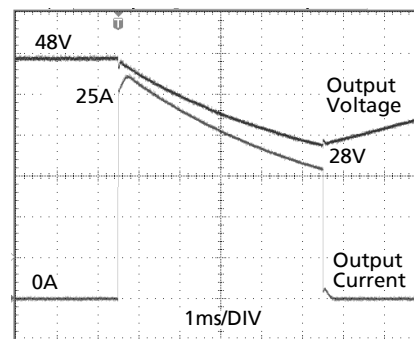

Peak load 25A (resistive) for 5ms  
Output voltage dips from 48V to 28V.

### 25.2. CHARGING OF BATTERIES

The power supply shall not be used to charge batteries. Choose Q-Series for charging batteries.



### 25.3. BACK-FEEDING LOADS

Loads such as decelerating motors and inductors can feed voltage back to the power supply. This feature is also called return voltage immunity or resistance against Back- E.M.F. (Electro Magnetic Force).

This power supply is resistant and does not show malfunctioning when a load feeds back voltage to the power supply. It does not matter, whether the power supply is on or off.

The maximum allowed feed back voltage is 63Vdc. The absorbing energy can be calculated according to the built-in large sized output capacitor which is specified in chapter 8.

### 25.4. OUTPUT CIRCUIT BREAKERS

Standard miniature circuit breakers (MCBs) can be used for branch protection. Ensure that the MCB is rated for DC voltage, too. The following tests show which circuit breakers the power supply typically trips.

Circuit breakers have huge tolerances in their tripping behavior. Therefore, these typical tests can only be used as a recommendation or for comparing two different power supplies. Furthermore, the loop impedance has a major influence on whether a breaker trips or not. Two tests were performed, representing typical situations:

**Test 1:** Short circuit with S1 on the power supply end of the cable (loop impedance approx. 20mOhm)

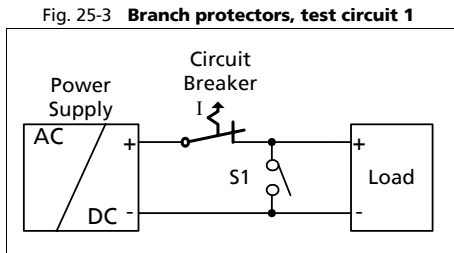

Parameters:

Input voltage: 230Vac, load current: 0A

The following circuit breaker tripped during the test:

- A- or Z- Characteristic:** equal or smaller 25A
- B- Characteristic:** equal or smaller 16A
- C- Characteristic:** equal or smaller 10A

**Test 2:** Short circuit with S1 on the load end (additional impedance included; represents longer load wire length).

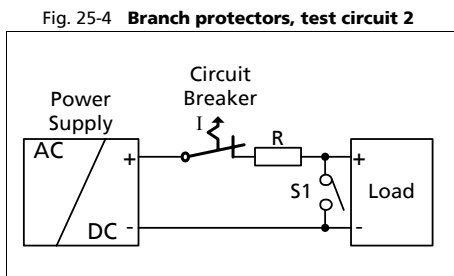

Parameters:

Input voltage: 230Vac, load current: 0A

The following circuit breaker tripped during the test:

- A- or Z- Characteristic:** ≤ 16A and R= 82mOhm
- B- Characteristic:** ≤ 6A and R= 180mOhm
- C- Characteristic:** ≤ 6A and R= 180mOhm

What does this resistance mean in wire length?

	0.5mm <sup>2</sup>	0.7mm <sup>2</sup>	1.0mm <sup>2</sup>	1.5mm <sup>2</sup>	2.5mm <sup>2</sup>	4.0mm <sup>2</sup>
<b>82mOhm</b>	2.3m	3.2m	4.6m	6.9m	11.4m	18.3m
<b>180mOhm</b>	5.0m	7.0m	10.0m	15.0m	25.1m	40.1m

**Example:**

Which wire gauge must be used to trip a B-Characteristic circuit breaker with a rating of 6A? The load wire length is 21m.

Answer: A 6A B-Characteristic circuit breaker requires a loop impedance of less than 180mOhm (test results). The wire length table shows that up to 25.1m wire with a cross section of 2.5mm<sup>2</sup> are below 180mOhm. A wire not smaller than 2.5mm<sup>2</sup> shall be used.

### 25.5. INDUCTIVE AND CAPACITIVE LOADS

The unit is designed to supply any kind of load, including unlimited capacitive and inductive loads.

### 25.6. SERIES OPERATION

The power supply can be put in series to increase the output voltage.

Fig. 25-5 Schematic for series operation

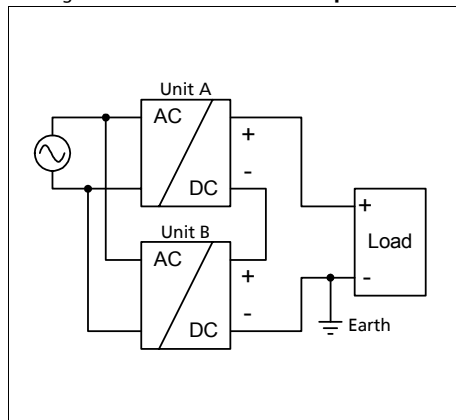

#### Instructions for use in series:

- It is possible to connect as many units in series as needed, providing the sum of the output voltage does not exceed 150Vdc.
- Voltages with a potential above 60Vdc are not SELV any more and can be dangerous. Such voltages must be installed with a protection against touching.
- For serial operation use power supplies of the same type.
- Earthing of the output is required when the sum of the output voltage is above 60Vdc.
- Keep an installation clearance of 15mm (left/right) between two power supplies and avoid installing the power supplies on top of each other.

**Note:** Avoid return voltage (e.g. from a decelerating motor or battery) which is applied to the output terminals.

### 25.7. PARALLEL USE TO INCREASE OUTPUT POWER

The power supply shall not be used in parallel to increase the output power.

### 25.8. PARALLEL USE FOR 1+1 REDUNDANCY

Power supplies can be paralleled for 1+1 redundancy to gain a higher system availability. Redundant systems require a certain amount of extra power to support the load in case one power supply unit fails. The simplest way is to put two C-Series power supplies in parallel. In case one power supply unit fails, the other one is automatically able to support the load current without any interruption. This simple way to build a redundant system has two major disadvantages:

- The faulty power supply can not be recognized. The green LED will still be on since it is reverse-powered from the other power supply.
- It does not cover failures such as an internal short circuit in the secondary side of the power supply. In such a - virtually nearly impossible - case, the defective unit becomes a load for the other power supplies and the output voltage can not be maintained any more.

This can only be avoided by utilizing decoupling diodes which are included in the decoupling module YR2.DIODE or redundancy module YRM2.DIODE.

Recommendations for building redundant power systems:

- Use separate input fuses for each power supply.
- Monitor the individual power supply units. A DC-ok lamp and a DC-ok contact is included in the redundancy module YRM2.DIODE. This feature reports a faulty unit.
- When possible, connect each power supply to different phases or circuits.

### 25.9. EXTERNAL INPUT PROTECTION

The unit is tested and approved for branch circuits up to 20A. External protection is only required if the supplying branch has an ampacity greater than this. In some countries local regulations might apply. Check also local codes and local requirements.

If an external fuse is necessary or utilized, a minimum value is required to avoid undesired tripping of the fuse.

		B-Characteristic	C-Characteristic
Ampacity	max.	20A	20A
	min.	10A	6A

### 25.10. OPERATION ON TWO PHASES

Fig. 25-6 Schematic for two phase operation

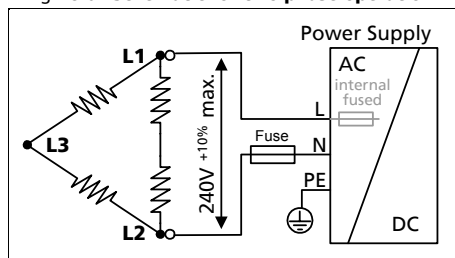

#### Instructions for two phase operation:

- A phase to phase connection is allowed as long as the supplying voltage is below 240V<sup>+10%</sup>.
- Use a fuse or a circuit breaker to protect the N input. The N input is internally not protected and is in this case connected to a hot wire.

Appropriate fuses or circuit breakers are specified in section 25.9 "External Input Protection".

### 25.11. USE IN A TIGHTLY SEALED ENCLOSURE

When the power supply is installed in a tightly sealed enclosure, the temperature inside the enclosure will be higher than outside. The inside temperature defines the ambient temperature for the power supply.

Results from such an installation:

Power supply is placed in the middle of the box, no other heat producer inside the box

Enclosure:	Rittal Type IP66 Box PK 9519 100, plastic, 180x180x165mm
Load:	48V, 4A; (=80%) load is placed outside the box
Input:	230Vac
Temperature inside the box:	48.9°C (in the middle of the right side of the power supply with a distance of 2cm)
Temperature outside the box:	23.3°C
Temperature rise:	25.6K

### 25.12. MOUNTING ORIENTATIONS

Mounting orientations other than input terminals on the bottom and output on the top require a reduction in continuous output power or a limitation in the max. allowed ambient temperature. The amount of reduction influences the lifetime expectancy of the power supply. Therefore, two different derating curves for continuous operation can be found below:

**Curve A1** Recommended output current.

**Curve A2** Max allowed output current (results approx. in half the lifetime expectancy of A1).

Fig. 25-7  
**Mounting Orientation A**  
Standard Orientation

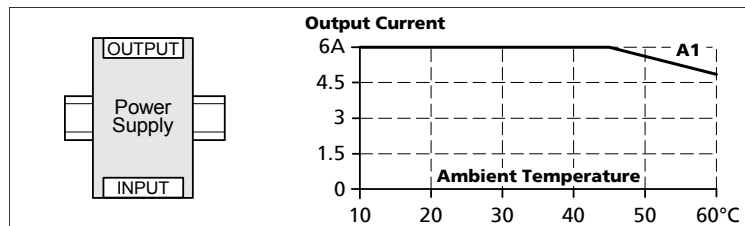

Fig. 25-8  
**Mounting Orientation B**  
(Upside down)

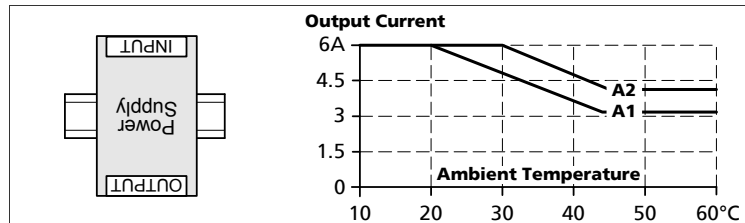

Fig. 25-9  
**Mounting Orientation C**  
(Table-top mounting)

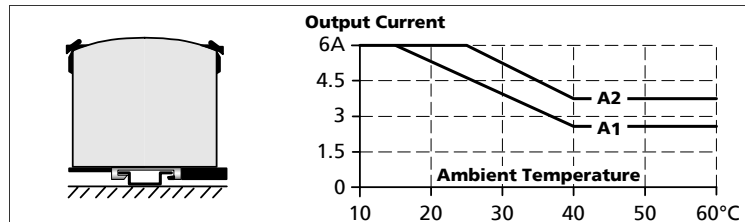

Fig. 25-10  
**Mounting Orientation D**  
(Horizontal cw)

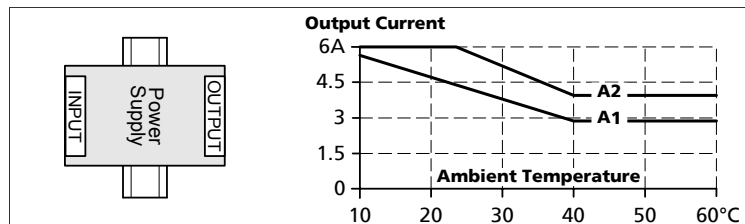

Fig. 25-11  
**Mounting Orientation E**  
(Horizontal ccw)

