

OSRAM OSTAR Observation (850nm) Lead (Pb) Free Product - RoHS Compliant

SFH 4761



SFH 4761

- Weißer Rahmen für hohe Lichtleistung
- 4.3 W optische Leistung bei IF=1A

Wesentliche Merkmale

- Aktive Chipfläche 2.1 x 5.4 mm²
- max. Gleichstrom 1 A
- niedriger Wärmewiderstand (2.8 K/W)
- Emissionswellenlänge 850 nm
- ESD-sicher bis 2 kV nach JESD22-A114-E
- Augensicherheitsrichtlinien der IEC-Normen 60825-1 und 62471 müssen beachtet werden.

Anwendungen

- Infrarotbeleuchtung für Kameras
- Überwachungssysteme
- IR-Datenübertragung
- Fahrer-Assistenz Systeme

SFH 4761

- White frame to achieve high optical power
- 4.3 W optical power at IF=1A

Features

- Active chip area 2.1 x 5.4 mm²
- max. DC-current 1 A
- Low thermal resistance (2.8 K/W)
- Spectral emission at 850 nm
- ESD safe up to 2 kV acc. to JESD22-A114-E
- Eye safety precautions given in IEC 60825-1 and IEC 62471 have to be followed.

Applications

- Infrared Illumination for cameras
- Surveillance systems
- IR Data Transmission
- Driver assistance systems

Typ Type	Bestellnummer Ordering Code	Strahlstärke ¹⁾ ($I_F = 1A, t_p = 20 ms$) Radiant intensity ¹⁾ I_e (mW/sr)
SFH 4761	Q65110A8758	> 1120 (typ.1400)

¹⁾ gemessen bei einem Raumwinkel $\Omega = 0.01 sr$ / measured at a solid angle of $\Omega = 0.01 sr$.

Grenzwerte
Maximum Ratings

Bezeichnung Parameter	Symbol Symbol	Wert Value	Einheit Unit
Betriebs- und Lagertemperatur Operating and storage temperature range	$T_{B, op}, T_{B, stg}$	- 40 ... + 125	°C
Sperrschichttemperatur Junction temperature	T_J	+ 145	°C
Sperrspannung Reverse voltage	V_R	0.5	V
Vorwärtsgleichstrom, $T_B^{1)} \leq 90$ °C Forward current	I_F	1	A
Stoßstrom, $t_p < 3$ ms, $D = 0$ Surge current	I_{FSM}	5	A
Leistungsaufnahme, $T_B \leq 90$ °C Power consumption	P_{tot}	19	W
Thermische Verlustleistung, $T_B \leq 90$ °C Thermal power-dissipation	P_{th}	14.7	W
Wärmewiderstand Sperrschicht / Bodenplatte Thermal resistance Junction / Base plate	R_{thJB}	2.8	K/W

¹⁾ T_B = Temperatur auf der Rückseite der Metallkernplatte / Temperature at the backside of the base plate.

Kennwerte ($T_B = 25\text{ °C}$)

Characteristics

Bezeichnung Parameter	Symbol Symbol	Wert Value	Einheit Unit
Wellenlänge der Strahlung Wavelength at peak emission $I_F = 1\text{ A}$, $t_p = 10\text{ ms}$	λ_{peak}	860	nm
Schwerpunkts-Wellenlänge der Strahlung Centroid wavelength $I_F = 1\text{ A}$, $t_p = 10\text{ ms}$	$\lambda_{\text{centroid}}$	850	nm
Spektrale Bandbreite bei 50% von I_{max} Spectral bandwidth at 50% of I_{max} $I_F = 1\text{ A}$, $t_p = 10\text{ ms}$	$\Delta\lambda$	30	nm
Abstrahlwinkel Half angle	φ	± 60	Grad deg.
Abmessungen der aktiven Chipfläche ¹⁾ Dimension of the active chip area	$L \times B$ $L \times W$	2.1×5.4	mm ²
Schaltzeiten, I_e von 10% auf 90% und von 90% auf 10%, $I_F = 5\text{ A}$, $R_L = 50\ \Omega$ Switching times, I_e from 10% to 90% and from 90% to 10%, $I_F = 5\text{ A}$, $R_L = 50\ \Omega$	t_r , t_f	10, 10	ns
Durchlassspannung Forward voltage $I_F = 1\text{ A}$, $t_p = 100\ \mu\text{s}$	V_F	15.5 (≤ 19)	V
Gesamtstrahlungsfluss Total radiant flux $I_F = 1\text{ A}$, $t_p = 100\ \mu\text{s}$	Φ_e	4.3	W
Temperaturkoeffizient von I_e bzw. Φ_e Temperature coefficient of I_e or Φ_e $I_F = 1\text{ A}$, $t_p = 10\text{ ms}$	TC_I	- 0.3	%/K
Temperaturkoeffizient von V_F Temperature coefficient of V_F $I_F = 1\text{ A}$, $t_p = 10\text{ ms}$	TC_V	- 10	mV/K
Temperaturkoeffizient von λ Temperature coefficient of λ $I_F = 1\text{ A}$, $t_p = 10\text{ ms}$	$TC_{\lambda, \text{centroid}}$	+ 0.3	nm/K

¹⁾ Die aktive Chipfläche besteht aus 10 einzelnen Chips mit je $1 \times 1\text{ mm}^2$.
The active chip area consists of 10 single chips with $1 \times 1\text{ mm}^2$ each.

Strahlstärke I_e
Radiant Intensity¹⁾ I_e

Bezeichnung Parameter	Symbol	Werte Values	Einheit Unit
		SFH 4761	
Strahlstärke Radiant Intensity $I_F = 1 \text{ A}, t_p = 20 \text{ ms}$	$I_{e \text{ min}}$ $I_{e \text{ max}}$	1120 2000	mW/sr mW/sr

Abstrahlcharakteristik
Radiation Characteristics $I_{\text{rel}} = f(\varphi)$

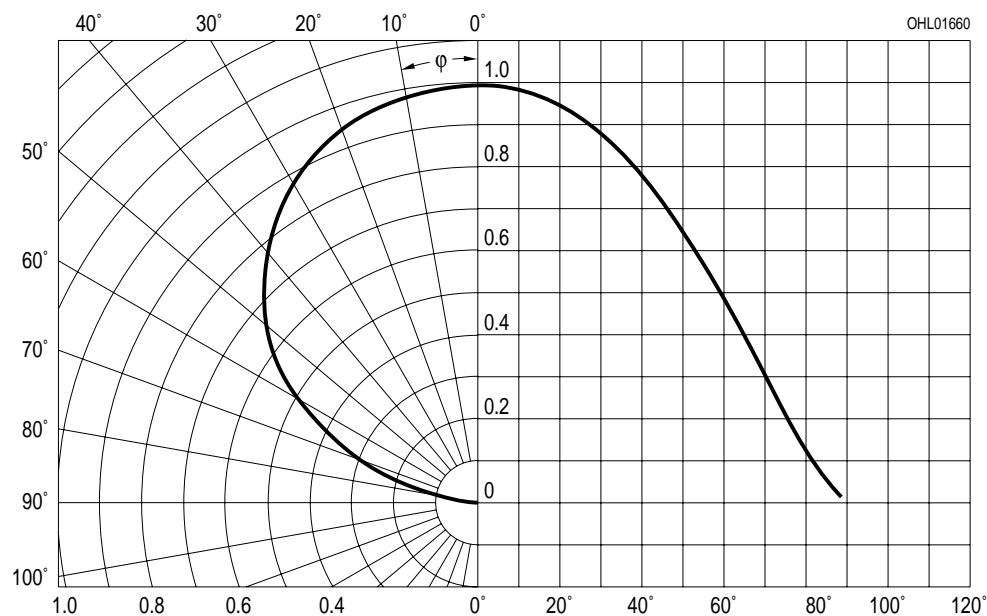

Relative spektrale Emission
Relative Spectral Emission

$I_{rel} = f(\lambda), T_B = 25\text{ }^\circ\text{C}$

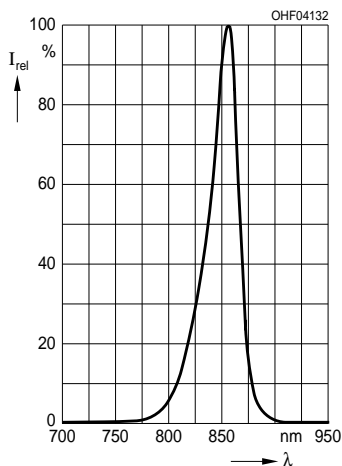

Durchlassstrom
Forward Current

$I_F = f(V_F), T_B = 25\text{ }^\circ\text{C}$,
Single pulse, $t_p = 100\text{ }\mu\text{s}$

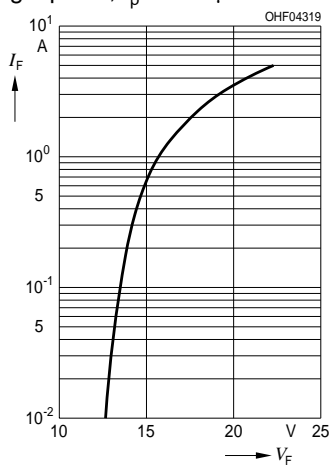

Relativer Gesamtstrahlungsfluss
Relative Total Radiant Flux

$\Phi_e / \Phi_e(1\text{ A}) = f(I_F), T_B = 25\text{ }^\circ\text{C}$,
Single pulse, $t_p = 100\text{ }\mu\text{s}$

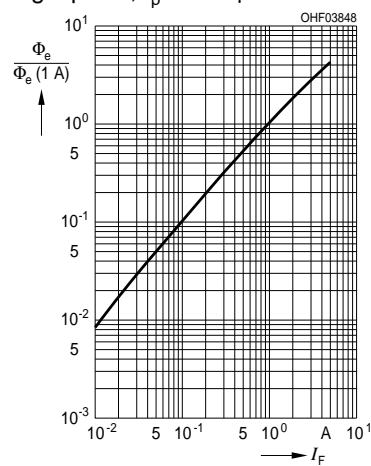

Max. zulässiger Durchlassstrom
Max. Permissible Forward Current

$I_F = f(T_B), R_{thJB} = 2.8\text{ K/W}$

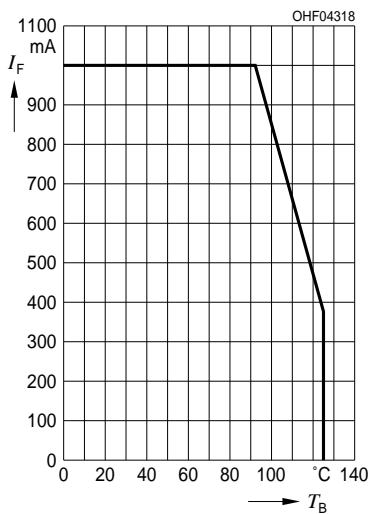

Zulässige Impulsbelastbarkeit
Permissible Pulse Handling

Capability $I_F = f(t_p), T_B = 85\text{ }^\circ\text{C}$,
Duty cycle $D = \text{parameter}$

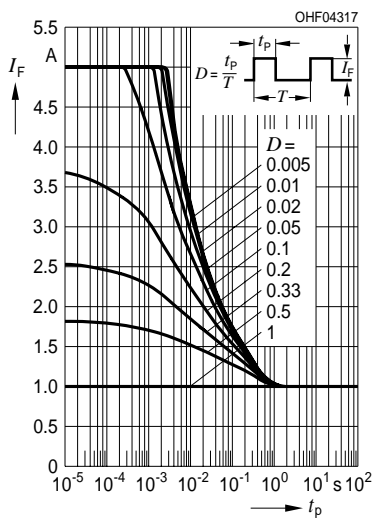

SMD NTC Thermistor mit Nickel Barrier Termination, Typ 0603
SMD NTC Thermistor with Nickel Barrier Termination, Type 0603

No. of R/T characteristics	R_{25} [Ω]	$B_{25/50}$ [K]	$B_{25/85}$ [K]	$B_{25/100}$ [K]
EPCOS 8502 / A01	10k \pm 5%	3940	3980	4000

Typische Thermistor Kennlinie
Typical Thermistor Graph

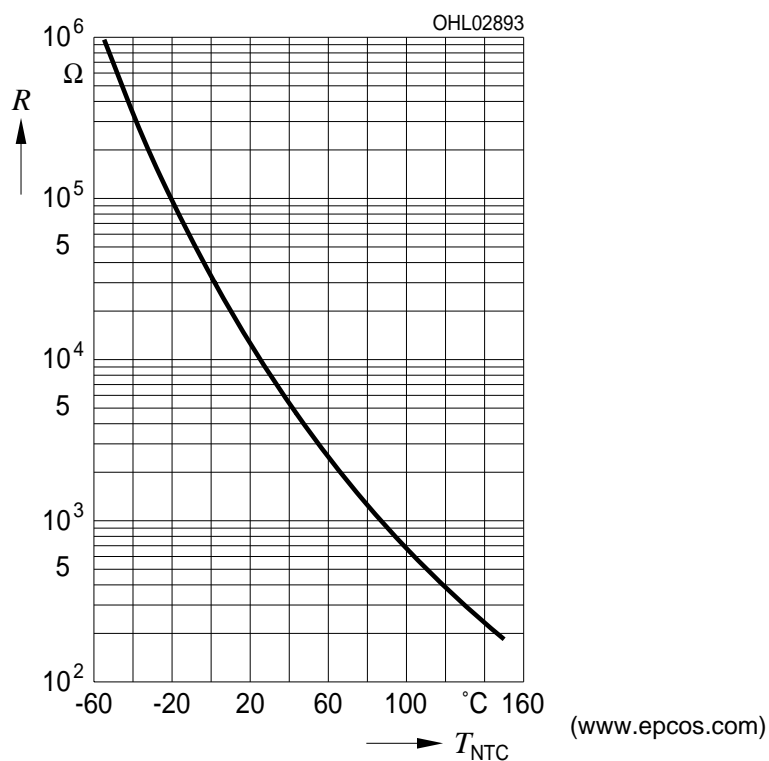

Maßzeichnung und Maßzeichnung und Ersatzschaltbild Package Outlines and equivalent circuit diagram

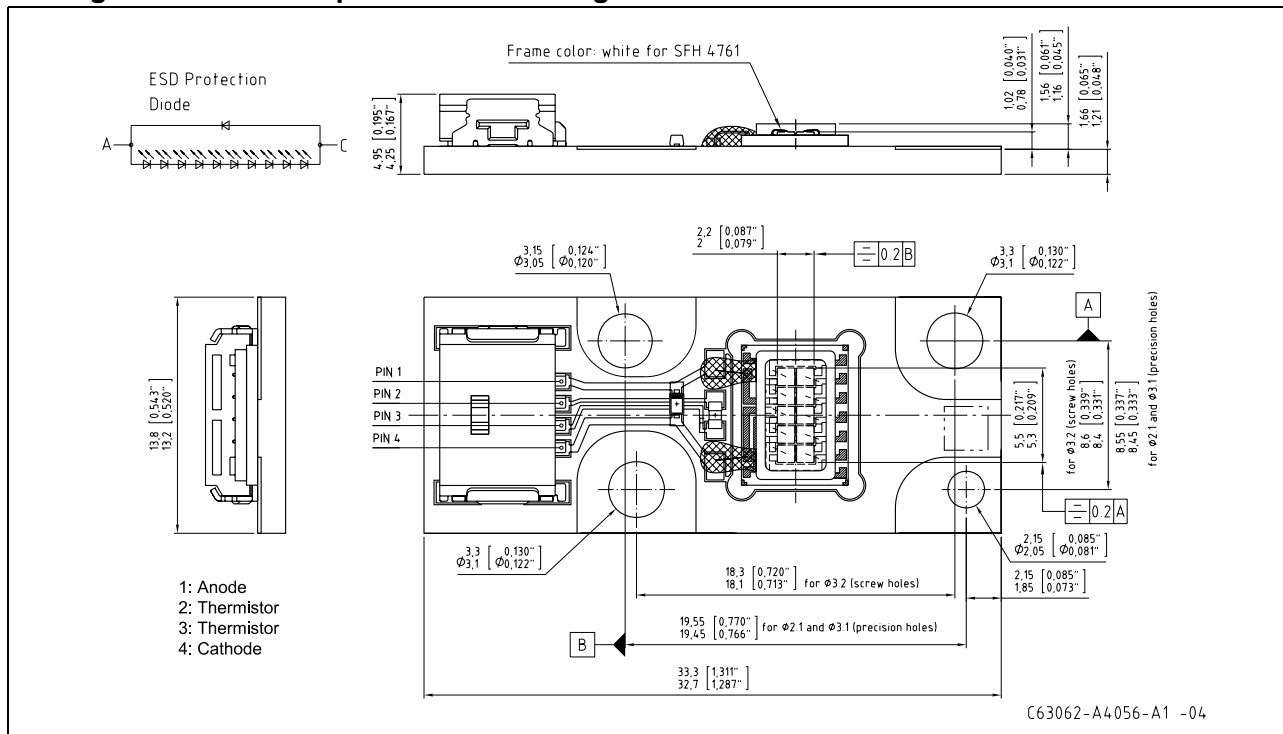

Maße in mm (inch) / Dimensions in mm (inch).

Verwendeter Stecker / Used male connector on board:
ERNI male connector SMD 214012, 4-pins (www.erni.com)

Empfohlene Gegenstecker / Recommended female connector for power supply:
ERNI female connector SMD 214025, 4-pins (www.erni.com)

Published by OSRAM Opto Semiconductors GmbH
Leibnizstraße 4, D-93055 Regensburg
www.osram-os.com

© All Rights Reserved.

The information describes the type of component and shall not be considered as assured characteristics. Terms of delivery and rights to change design reserved. Due to technical requirements components may contain dangerous substances. For information on the types in question please contact our Sales Organization.

Packing

Please use the recycling operators known to you. We can also help you – get in touch with your nearest sales office. By agreement we will take packing material back, if it is sorted. You must bear the costs of transport. For packing material that is returned to us unsorted or which we are not obliged to accept, we shall have to invoice you for any costs incurred.

Components used in life-support devices or systems must be expressly authorized for such purpose! Critical components¹, may only be used in life-support devices or systems² with the express written approval of OSRAM OS.

¹ A critical component is a component used in a life-support device or system whose failure can reasonably be expected to cause the failure of that life-support device or system, or to affect its safety or effectiveness of that device or system.

² Life support devices or systems are intended (a) to be implanted in the human body, or (b) to support and/or maintain and sustain human life. If they fail, it is reasonable to assume that the health of the user may be endangered.

EU RoHS and China RoHS compliant product



此产品符合欧盟 RoHS 指令的要求；

按照中国的相关法规和标准，不含有毒有害物质或元素。