

MD51V65405**16,777,216-Word × 4-Bit DYNAMIC RAM : FAST PAGE MODE TYPE WITH EDO****DESCRIPTION**

The MD51V65405 is a 16,777,216-word × 4-bit dynamic RAM fabricated in Oki's silicon-gate CMOS technology. The MD51V65405 achieves high integration, high-speed operation, and low-power consumption because Oki manufactures the device in a quadruple-layer polysilicon/double-layer metal CMOS process. The MD51V65405 is available in a 32-pin plastic SOJ or 32-pin plastic TSOP.

FEATURES

- 16,777,216-word × 4-bit configuration
 - Single 3.3 V power supply, ±0.3 V tolerance
 - Input : LVTTTL compatible, low input capacitance
 - Output : LVTTTL compatible, 3-state
 - Refresh :
 - $\overline{\text{RAS}}$ -only refresh : 4096 cycles/64 ms
 - $\overline{\text{CAS}}$ before $\overline{\text{RAS}}$ refresh, hidden refresh : 4096 cycles/64 ms
 - Fast page mode with EDO, read modify write capability
 - $\overline{\text{CAS}}$ before $\overline{\text{RAS}}$ refresh, hidden refresh, $\overline{\text{RAS}}$ -only refresh capability
 - Package options:
 - 32-pin 400 mil plastic SOJ (SOJ32-P-400-1.27) (Product : MD51V65405-xxJA)
 - 32-pin 400 mil plastic TSOP (TSOPII32-P-400-1.27-K) (Product : MD51V65405-xxTA)
- xx indicates speed rank.

PRODUCT FAMILY

Family	Access Time (Max.)				Cycle Time (Min.)	Power Dissipation	
	t _{RAC}	t _{AA}	t _{CAC}	t _{OEA}		Operating (Max.)	Standby (Max.)
MD51V65405-50	50 ns	25 ns	13 ns	13 ns	84 ns	504 mW	1.8 mW
MD51V65405-60	60 ns	30 ns	15 ns	15 ns	104 ns	432 mW	

PIN CONFIGURATION (TOP VIEW)

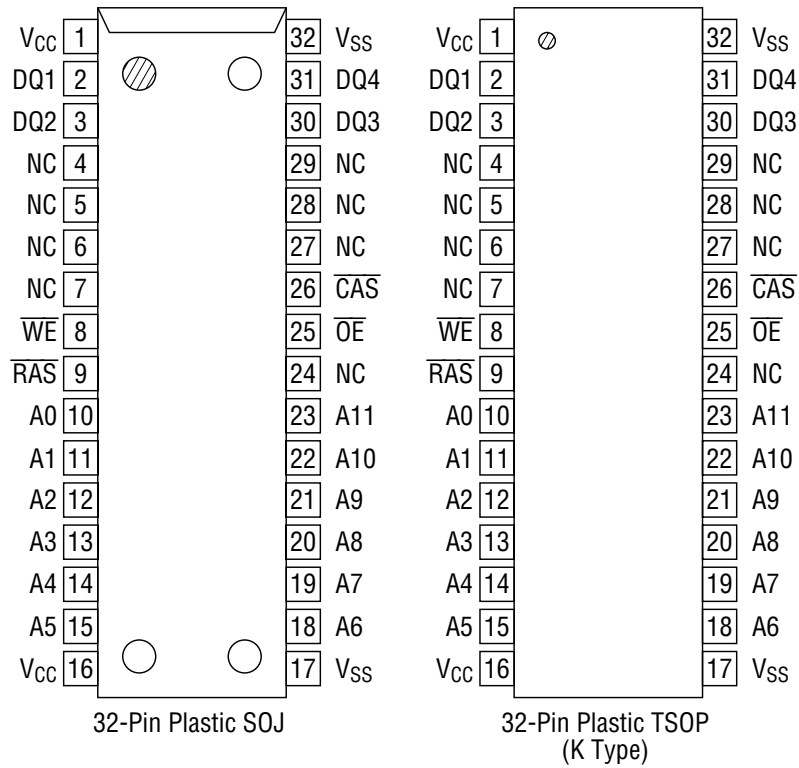

Pin Name	Function
A0 - A11	Address Input
$\overline{\text{RAS}}$	Row Address Strobe
$\overline{\text{CAS}}$	Column Address Strobe
DQ1 - DQ4	Data Input/Data Output
$\overline{\text{OE}}$	Output Enable
$\overline{\text{WE}}$	Write Enable
V _{CC}	Power Supply (3.3 V)
V _{SS}	Ground (0 V)
NC	No Connection

Note : The same power supply voltage must be provided to every V_{CC} pin, and the same GND voltage level must be provided to every V_{SS} pin.

BLOCK DIAGRAM

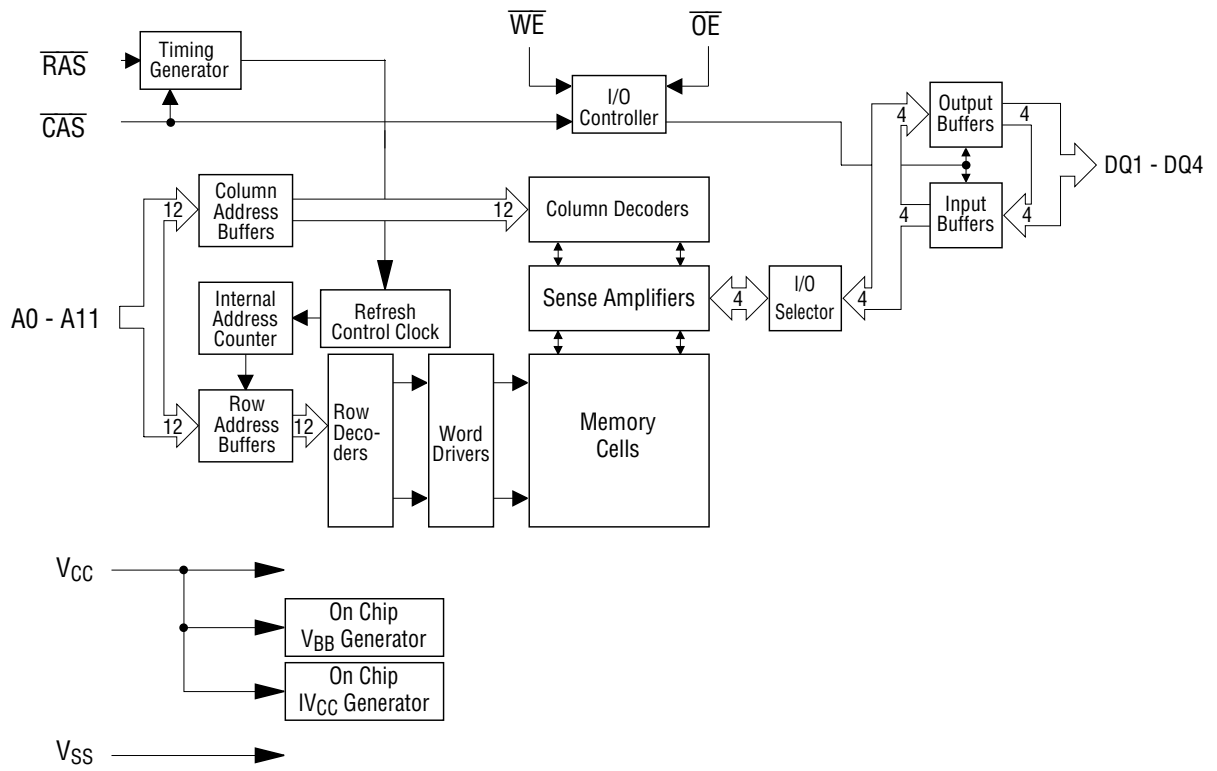

ELECTRICAL CHARACTERISTICS**Absolute Maximum Ratings**

Parameter	Symbol	Rating	Unit
Voltage on Any Pin Relative to V_{SS}	V_T	-0.5 to 4.6	V
Short Circuit Output Current	I_{OS}	50	mA
Power Dissipation	P_D^*	1	W
Operating Temperature	T_{opr}	0 to 70	°C
Storage Temperature	T_{stg}	-55 to 150	°C

*: $T_a = 25^\circ\text{C}$ **Recommended Operating Conditions** $(T_a = 0^\circ\text{C to } 70^\circ\text{C})$

Parameter	Symbol	Min.	Typ.	Max.	Unit
Power Supply Voltage	V_{CC}	3.0	3.3	3.6	V
	V_{SS}	0	0	0	V
Input High Voltage	V_{IH}	2.0	—	$V_{CC} + 0.3$	V
Input Low Voltage	V_{IL}	-0.3	—	0.8	V

Capacitance $(V_{CC} = 3.3 \text{ V} \pm 0.3 \text{ V}, T_a = 25^\circ\text{C}, f = 1 \text{ MHz})$

Parameter	Symbol	Typ.	Max.	Unit
Input Capacitance (A0 - A11)	C_{IN1}	—	5	pF
Input Capacitance (\overline{RAS} , \overline{CAS} , \overline{WE} , \overline{OE})	C_{IN2}	—	7	pF
Output Capacitance (DQ1 - DQ4)	$C_{I/O}$	—	7	pF

DC Characteristics

($V_{CC} = 3.3\text{ V} \pm 0.3\text{ V}$, $T_a = 0^\circ\text{C}$ to 70°C)

Parameter	Symbol	Condition	MD51V65405 -50		MD51V65405 -60		Unit	Note
			Min.	Max.	Min.	Max.		
Output High Voltage	V_{OH}	$I_{OH} = -2.0\text{ mA}$	2.4	V_{CC}	2.4	V_{CC}	V	
Output Low Voltage	V_{OL}	$I_{OL} = 2.0\text{ mA}$	0	0.4	0	0.4	V	
Input Leakage Current	I_{LI}	$0\text{ V} \leq V_I \leq V_{CC} + 0.3\text{ V}$; All other pins not under test = 0 V	-10	10	-10	10	μA	
Output Leakage Current	I_{LO}	DQ disable $0\text{ V} \leq V_O \leq V_{CC}$	-10	10	-10	10	μA	
Average Power Supply Current (Operating)	I_{CC1}	$\overline{\text{RAS}}$, $\overline{\text{CAS}}$ cycling, $t_{RC} = \text{Min.}$	—	140	—	120	mA	1, 2
Power Supply Current (Standby)	I_{CC2}	$\overline{\text{RAS}}$, $\overline{\text{CAS}} = V_{IH}$	—	1	—	1	mA	1
		$\overline{\text{RAS}}$, $\overline{\text{CAS}} \geq V_{CC} - 0.2\text{ V}$	—	0.5	—	0.5		
Average Power Supply Current ($\overline{\text{RAS}}$ -only Refresh)	I_{CC3}	$\overline{\text{RAS}}$ cycling, $\overline{\text{CAS}} = V_{IH}$, $t_{RC} = \text{Min.}$	—	140	—	120	mA	1, 2
Power Supply Current (Standby)	I_{CC5}	$\overline{\text{RAS}} = V_{IH}$, $\overline{\text{CAS}} = V_{IL}$, DQ = enable	—	5	—	5	mA	1
Average Power Supply Current ($\overline{\text{CAS}}$ before $\overline{\text{RAS}}$ Refresh)	I_{CC6}	$\overline{\text{RAS}}$ cycling, $\overline{\text{CAS}}$ before $\overline{\text{RAS}}$	—	140	—	120	mA	1, 2
Average Power Supply Current (Fast Page Mode)	I_{CC7}	$\overline{\text{RAS}} = V_{IL}$, $\overline{\text{CAS}}$ cycling, $t_{HPC} = \text{Min.}$	—	140	—	120	mA	1, 3

- Notes :
- I_{CC} Max. is specified as I_{CC} for output open condition.
 - The address can be changed once or less while $\overline{\text{RAS}} = V_{IL}$.
 - The address can be changed once or less while $\overline{\text{CAS}} = V_{IH}$.

AC Characteristics (1/2)

 $(V_{CC} = 3.3 V \pm 0.3 V, T_a = 0^\circ C \text{ to } 70^\circ C)$ Note 1, 2, 3

Parameter	Symbol	MD51V65405 -50		MD51V65405 -60		Unit	Note
		Min.	Max.	Min.	Max.		
Random Read or Write Cycle Time	t_{RC}	84	—	104	—	ns	
Read Modify Write Cycle Time	t_{RWC}	110	—	135	—	ns	
Fast Page Mode Cycle Time	t_{HPC}	20	—	25	—	ns	
Fast Page Mode Read Modify Write Cycle Time	t_{HPRWC}	58	—	68	—	ns	
Access Time from \overline{RAS}	t_{RAC}	—	50	—	60	ns	4, 5, 6
Access Time from \overline{CAS}	t_{CAC}	—	13	—	15	ns	4, 5
Access Time from Column Address	t_{AA}	—	25	—	30	ns	4, 6
Access Time from \overline{CAS} Precharge	t_{CPA}	—	30	—	35	ns	4
Access Time from \overline{OE}	t_{OEA}	—	13	—	15	ns	4
Output Low Impedance Time from \overline{CAS}	t_{CLZ}	0	—	0	—	ns	4
Data Output Hold After \overline{CAS} Low	t_{DOH}	5	—	5	—	ns	
\overline{CAS} to Data Output Buffer Turn-off Delay Time	t_{CEZ}	0	13	0	15	ns	7, 8
\overline{RAS} to Data Output Buffer Turn-off Delay Time	t_{REZ}	0	13	0	15	ns	7, 8
\overline{OE} to Data Output Buffer Turn-off Delay Time	t_{OEZ}	0	13	0	15	ns	7
\overline{WE} to Data Output Buffer Turn-off Delay Time	t_{WEZ}	0	13	0	15	ns	7
Transition Time	t_T	1	50	1	50	ns	3
Refresh Period	t_{REF}	—	64	—	64	ms	
\overline{RAS} Precharge Time	t_{RP}	30	—	40	—	ns	
\overline{RAS} Pulse Width	t_{RAS}	50	10,000	60	10,000	ns	
\overline{RAS} Pulse Width (Fast Page Mode with EDO)	t_{RASP}	50	100,000	60	100,000	ns	
\overline{RAS} Hold Time	t_{RSH}	7	—	10	—	ns	
\overline{RAS} Hold Time referenced to \overline{OE}	t_{ROH}	7	—	10	—	ns	
\overline{CAS} Precharge Time (Fast Page Mode with EDO)	t_{CP}	7	—	10	—	ns	
\overline{CAS} Pulse Width	t_{CAS}	7	10,000	10	10,000	ns	
\overline{CAS} Hold Time	t_{CSH}	35	—	40	—	ns	
\overline{CAS} to \overline{RAS} Precharge Time	t_{CRP}	5	—	5	—	ns	
\overline{RAS} Hold Time from \overline{CAS} Precharge	t_{RHCP}	30	—	35	—	ns	
\overline{OE} Hold Time from \overline{CAS} (DQ Disable)	t_{CHO}	5	—	5	—	ns	
\overline{RAS} to \overline{CAS} Delay Time	t_{RCD}	11	37	14	45	ns	5
\overline{RAS} to Column Address Delay Time	t_{RAD}	9	25	12	30	ns	6
Row Address Set-up Time	t_{ASR}	0	—	0	—	ns	
Row Address Hold Time	t_{RAH}	7	—	10	—	ns	
Column Address Set-up Time	t_{ASC}	0	—	0	—	ns	
Column Address Hold Time	t_{CAH}	7	—	10	—	ns	
Column Address to \overline{RAS} Lead Time	t_{RAL}	25	—	30	—	ns	

AC Characteristics (2/2)

(V_{CC} = 3.3 V ±0.3 V, T_a = 0°C to 70°C) Note 1, 2, 3

Parameter	Symbol	MD51V65405 -50		MD51V65405 -60		Unit	Note
		Min.	Max.	Min.	Max.		
Read Command Set-up Time	t _{RCS}	0	—	0	—	ns	
Read Command Hold Time	t _{RCH}	0	—	0	—	ns	9
Read Command Hold Time referenced to $\overline{\text{RAS}}$	t _{RRH}	0	—	0	—	ns	9
Write Command Set-up Time	t _{WCS}	0	—	0	—	ns	10
Write Command Hold Time	t _{WCH}	7	—	10	—	ns	
Write Command Pulse Width	t _{WP}	7	—	10	—	ns	
$\overline{\text{WE}}$ Pulse Width (DQ Disable)	t _{WPE}	7	—	10	—	ns	
$\overline{\text{OE}}$ Command Hold Time	t _{OEH}	7	—	10	—	ns	
$\overline{\text{OE}}$ Precharge Time	t _{OEP}	7	—	10	—	ns	
$\overline{\text{OE}}$ Command Hold Time	t _{OCH}	7	—	10	—	ns	
Write Command to $\overline{\text{RAS}}$ Lead Time	t _{RWL}	7	—	10	—	ns	
Write Command to $\overline{\text{CAS}}$ Lead Time	t _{CWL}	7	—	10	—	ns	
Data-in Set-up Time	t _{DS}	0	—	0	—	ns	11
Data-in Hold Time	t _{DH}	7	—	10	—	ns	11
$\overline{\text{OE}}$ to Data-in Delay Time	t _{OED}	13	—	15	—	ns	
$\overline{\text{CAS}}$ to $\overline{\text{WE}}$ Delay Time	t _{CWD}	30	—	34	—	ns	10
Column Address to $\overline{\text{WE}}$ Delay Time	t _{AWD}	42	—	49	—	ns	10
$\overline{\text{RAS}}$ to $\overline{\text{WE}}$ Delay Time	t _{RWD}	67	—	79	—	ns	10
$\overline{\text{CAS}}$ Precharge $\overline{\text{WE}}$ Delay Time	t _{CPWD}	47	—	54	—	ns	10
$\overline{\text{CAS}}$ Active Delay Time from $\overline{\text{RAS}}$ Precharge	t _{RPC}	5	—	5	—	ns	
$\overline{\text{RAS}}$ to $\overline{\text{CAS}}$ Set-up Time ($\overline{\text{CAS}}$ before $\overline{\text{RAS}}$)	t _{CSR}	5	—	5	—	ns	
$\overline{\text{RAS}}$ to $\overline{\text{CAS}}$ Hold Time ($\overline{\text{CAS}}$ before $\overline{\text{RAS}}$)	t _{CHR}	10	—	10	—	ns	
$\overline{\text{WE}}$ to $\overline{\text{RAS}}$ Precharge Time ($\overline{\text{CAS}}$ before $\overline{\text{RAS}}$)	t _{WRP}	10	—	10	—	ns	
$\overline{\text{WE}}$ Hold Time from $\overline{\text{RAS}}$ ($\overline{\text{CAS}}$ before $\overline{\text{RAS}}$)	t _{WRH}	10	—	10	—	ns	

- Notes:
1. A start-up delay of 200 μ s is required after power-up, followed by a minimum of eight initialization cycles ($\overline{\text{RAS}}$ -only refresh or $\overline{\text{CAS}}$ before $\overline{\text{RAS}}$ refresh) before proper device operation is achieved.
 2. The AC characteristics assume $t_T = 2$ ns.
 3. V_{IH} (Min.) and V_{IL} (Max.) are reference levels for measuring input timing signals. Transition times (t_T) are measured between V_{IH} and V_{IL} .
 4. This parameter is measured with a load circuit equivalent to 1 TTL load and 100 pF. The output timing reference levels are $V_{OH} = 2.0$ V and $V_{OL} = 0.8$ V.
 5. Operation within the t_{RCD} (Max.) limit ensures that t_{RAC} (Max.) can be met. t_{RCD} (Max.) is specified as a reference point only. If t_{RCD} is greater than the specified t_{RCD} (Max.) limit, then the access time is controlled by t_{CAC} .
 6. Operation within the t_{RAD} (Max.) limit ensures that t_{RAC} (Max.) can be met. t_{RAD} (Max.) is specified as a reference point only. If t_{RAD} is greater than the specified t_{RAD} (Max.) limit, then the access time is controlled by t_{AA} .
 7. t_{CEZ} (Max.), t_{REZ} (Max.), t_{WEZ} (Max.) and t_{OEZ} (Max.) define the time at which the output achieves the open circuit condition and are not referenced to output voltage levels.
 8. t_{CEZ} and t_{REZ} must be satisfied for open circuit condition.
 9. t_{RCH} or t_{RRH} must be satisfied for a read cycle.
 10. t_{WCS} , t_{CWD} , t_{RWD} , t_{AWD} and t_{CPWD} are not restrictive operating parameters. They are included in the data sheet as electrical characteristics only. If $t_{WCS} \geq t_{WCS}$ (Min.), then the cycle is an early write cycle and the data out will remain open circuit (high impedance) throughout the entire cycle. If $t_{CWD} \geq t_{CWD}$ (Min.), $t_{RWD} \geq t_{RWD}$ (Min.), $t_{AWD} \geq t_{AWD}$ (Min.) and $t_{CPWD} \geq t_{CPWD}$ (Min.), then the cycle is a read modify write cycle and data out will contain data read from the selected cell; if neither of the above sets of conditions is satisfied, then the condition of the data out (at access time) is indeterminate.
 11. These parameters are referenced to the $\overline{\text{CAS}}$ leading edge in an early write cycle, and to the $\overline{\text{WE}}$ leading edge in an $\overline{\text{OE}}$ control write cycle, or a read modify write cycle.

TIMING WAVEFORM

Read Cycle

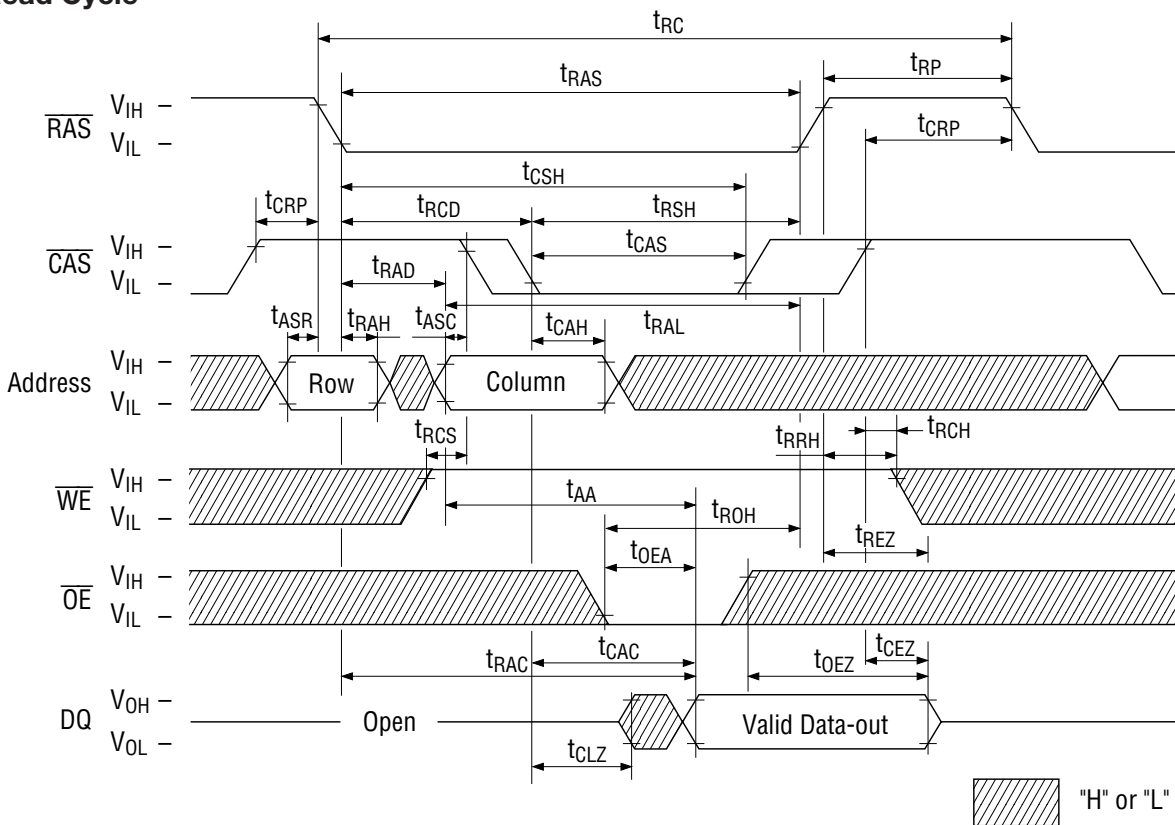

Write Cycle (Early Write)

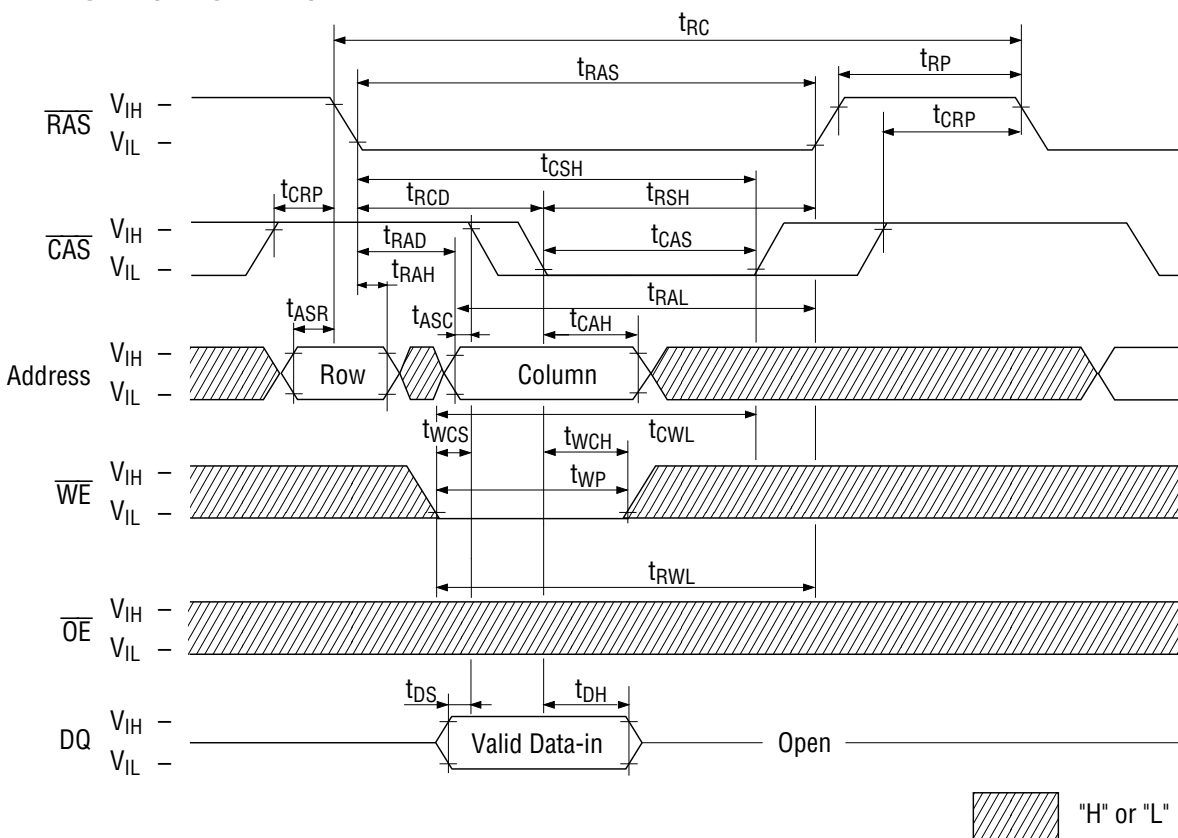

Read Modify Write Cycle

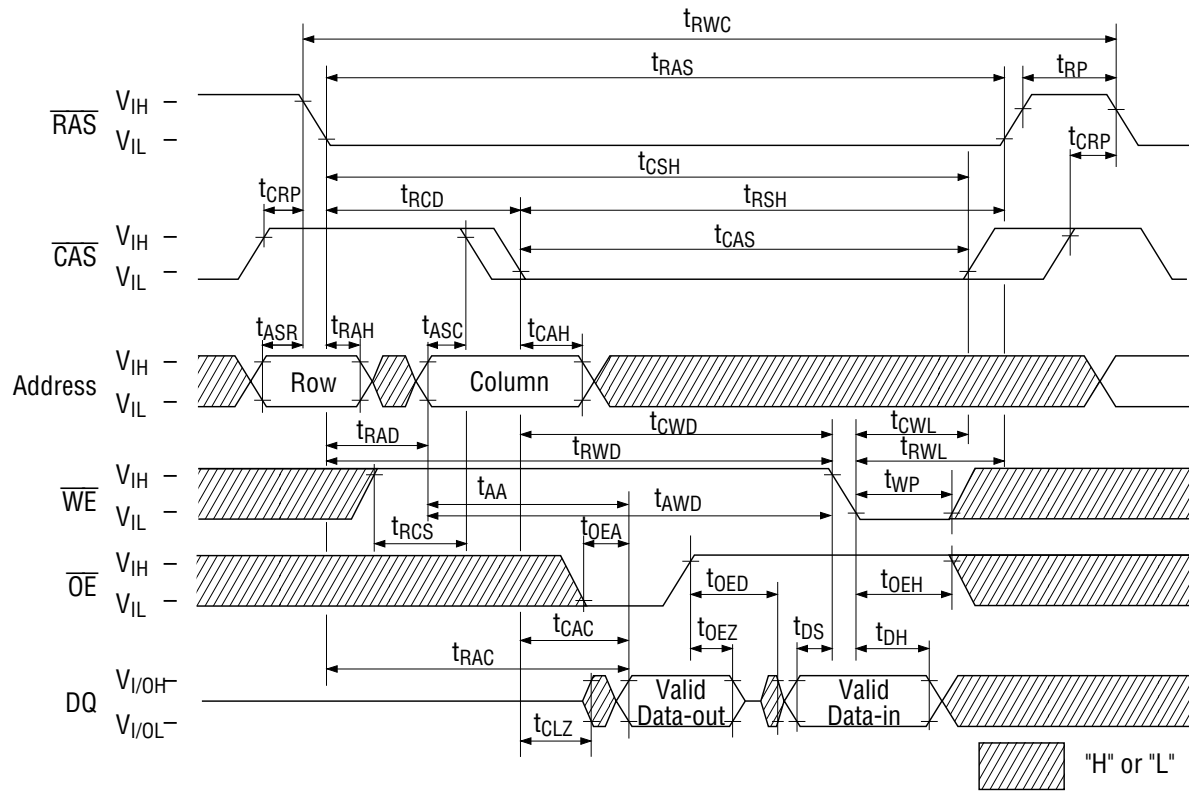

Fast Page Mode Read Cycle (Part-1)

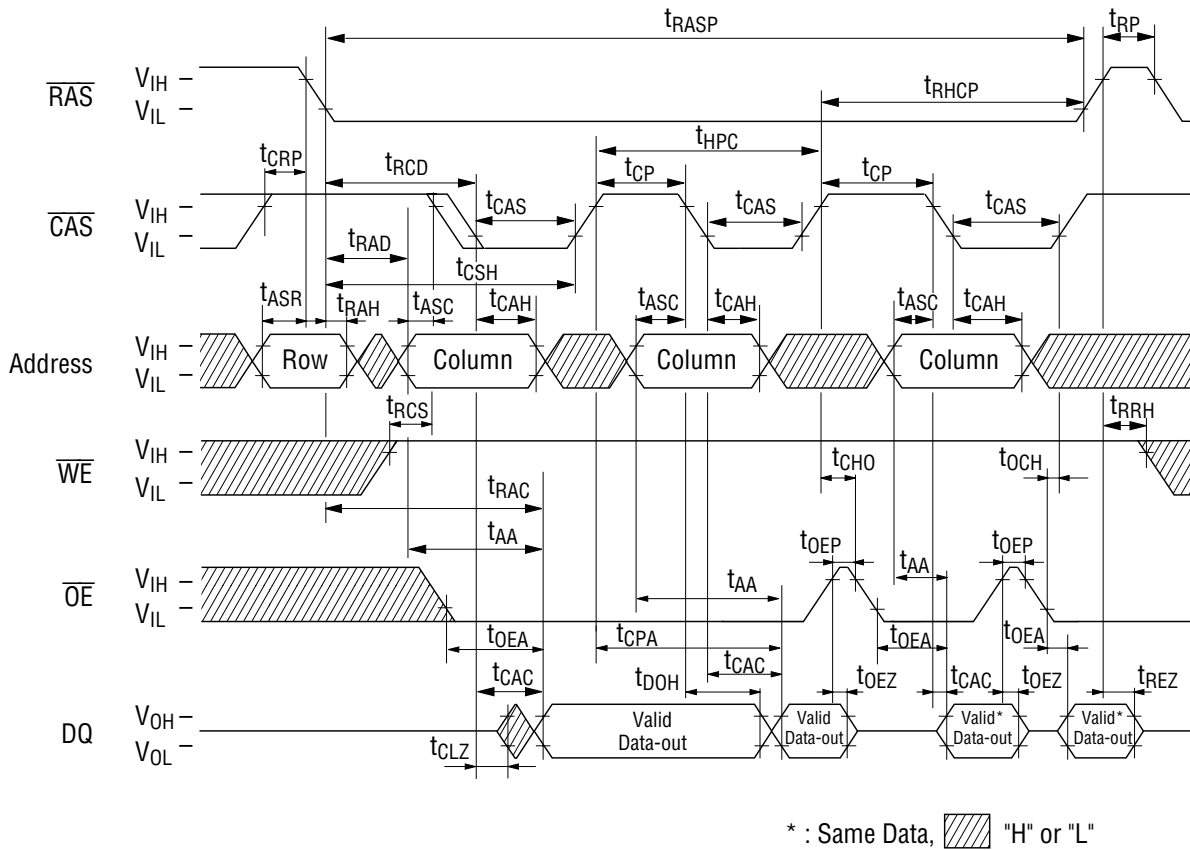

Fast Page Mode Read Cycle (Part-2)

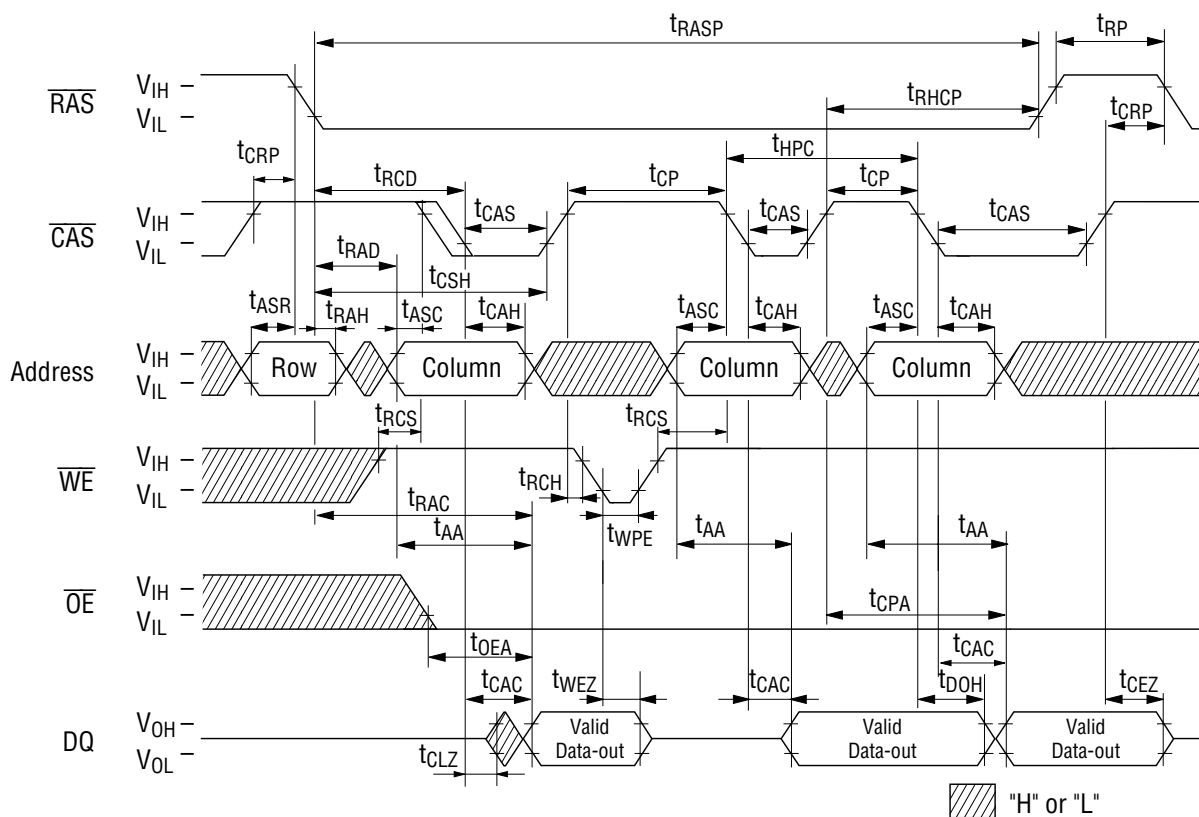

Fast Page Mode Write Cycle (Early Write)

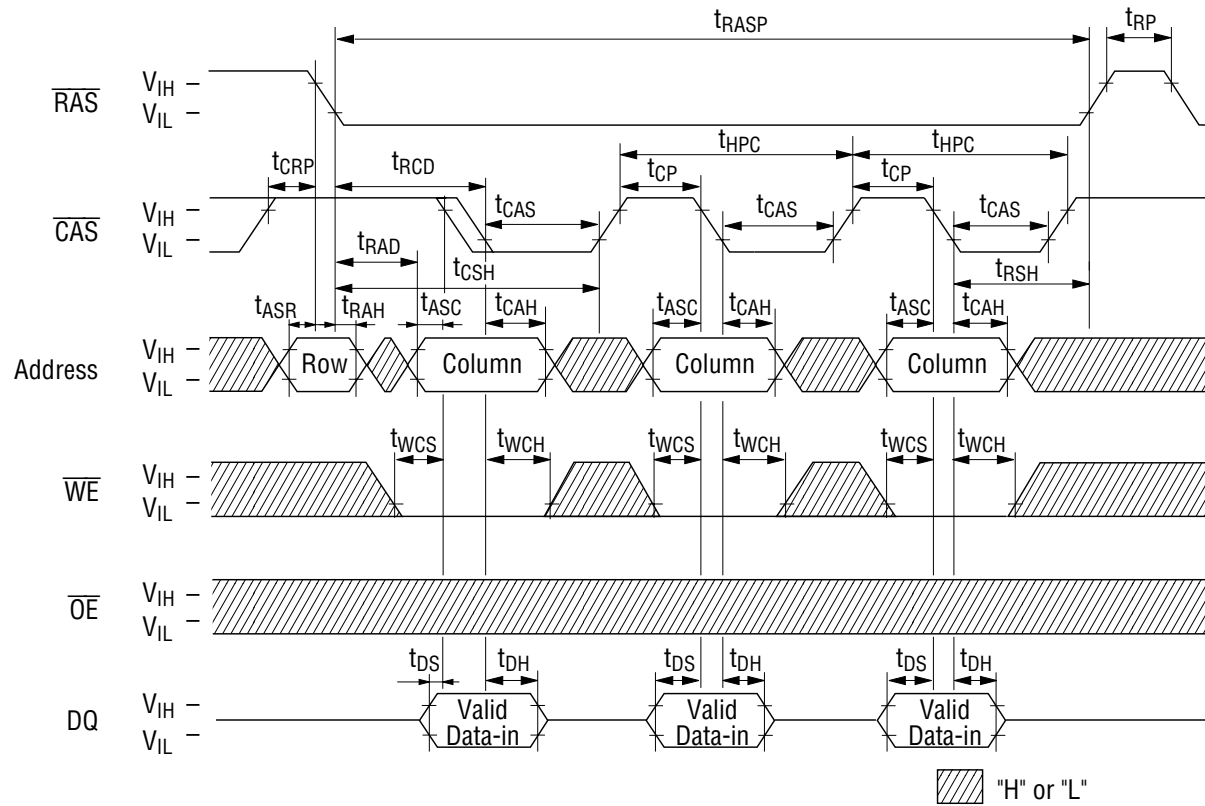

Fast Page Mode Read Modify Write Cycle

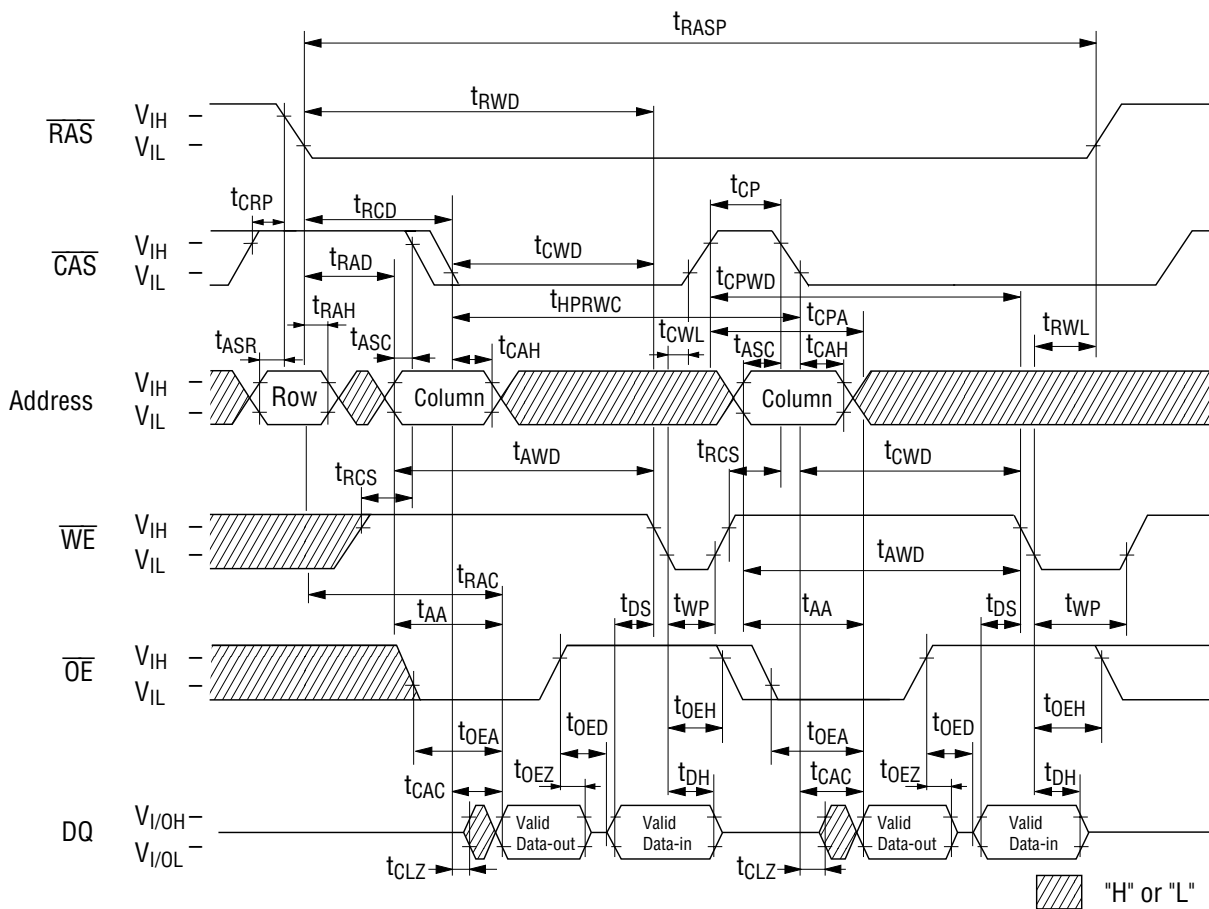

RAS-Only Refresh Cycle

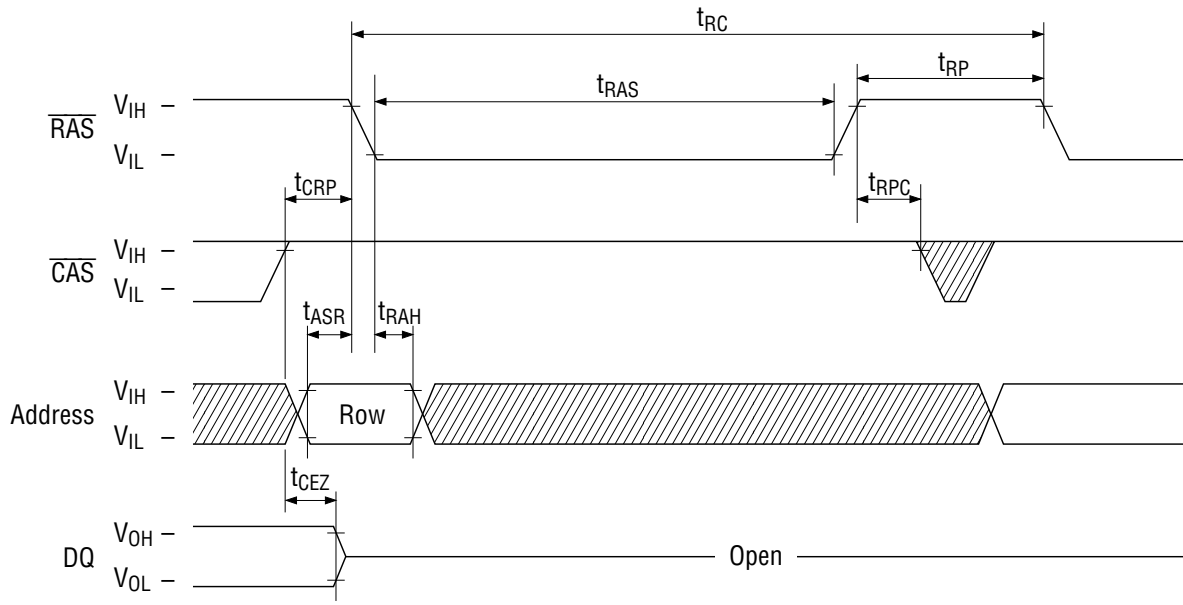

Note: $\overline{\text{WE}}, \overline{\text{OE}} = \text{"H" or "L"}$ "H" or "L"

CAS before RAS Refresh Cycle

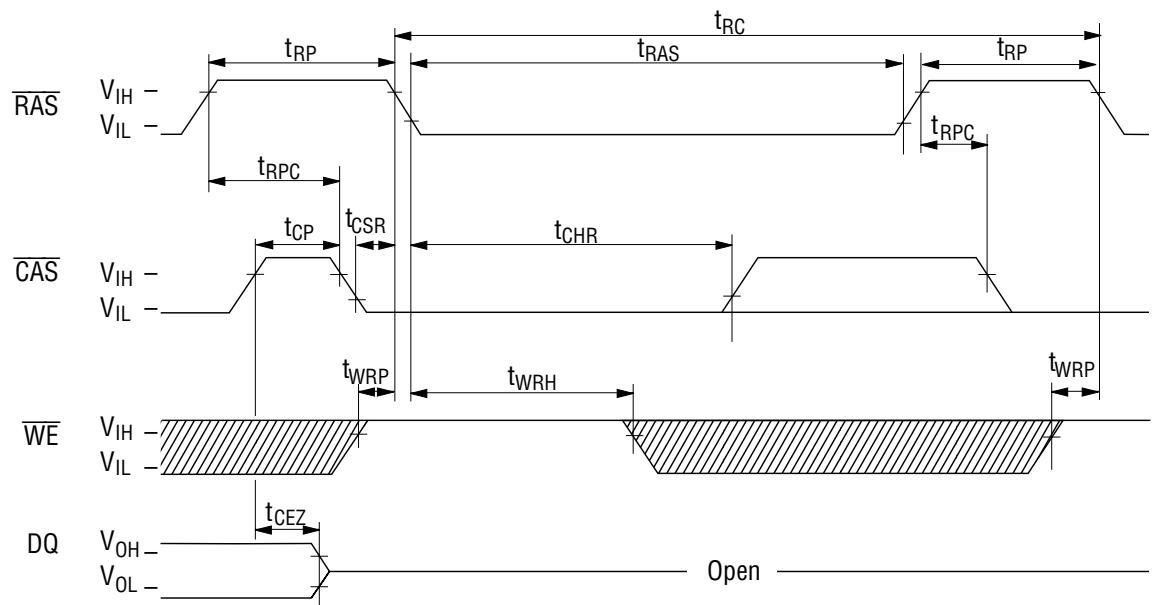

Note: $\overline{\text{OE}}, \text{Address} = \text{"H" or "L"}$ "H" or "L"

Hidden Refresh Read Cycle

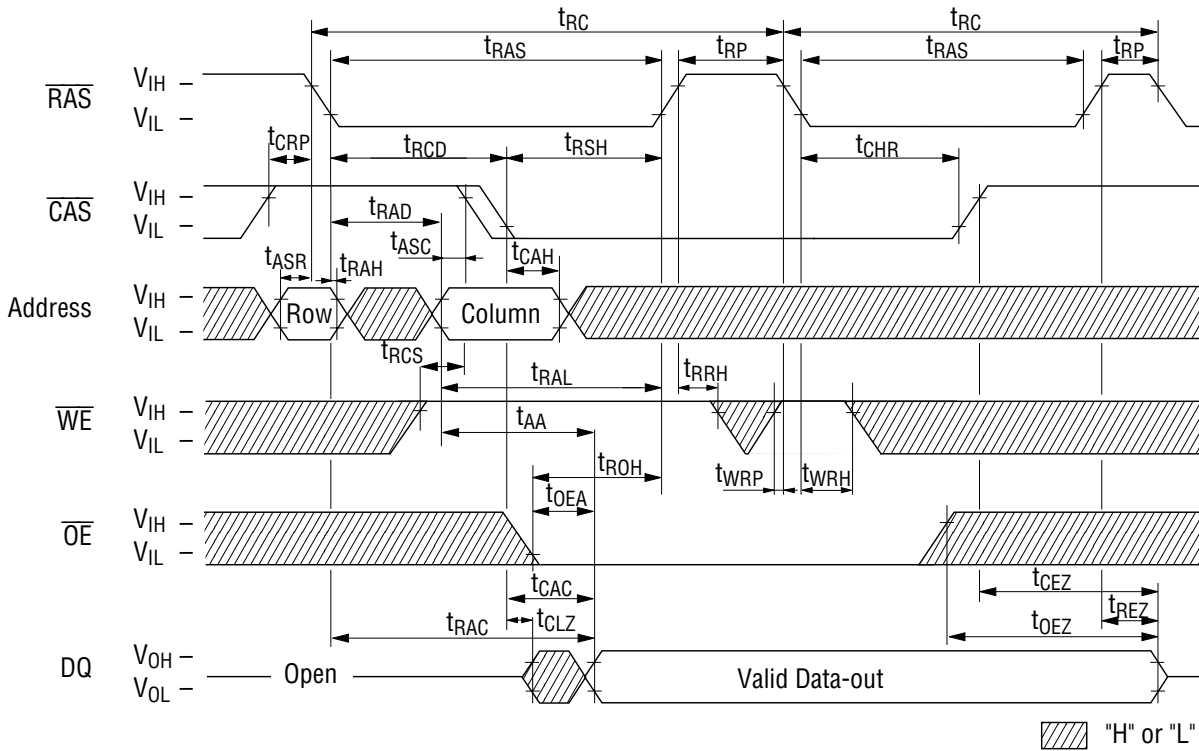

Hidden Refresh Write Cycle

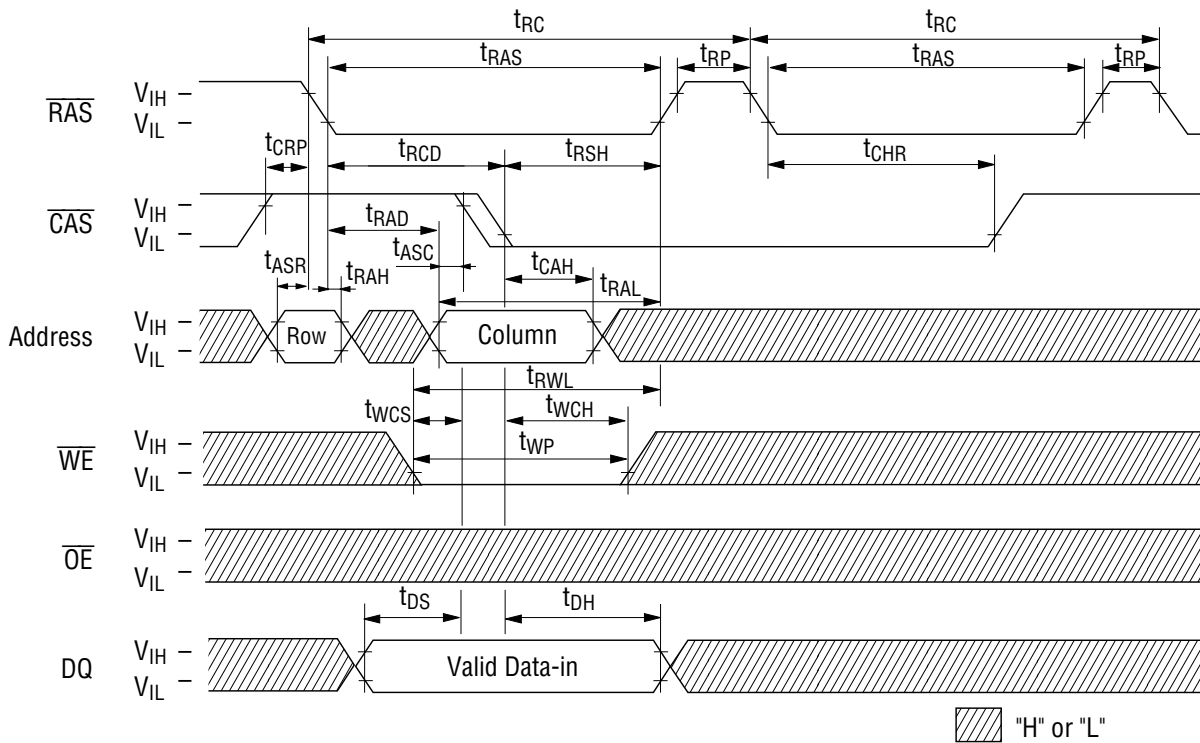

PACKAGE DIMENSIONS

(Unit : mm)

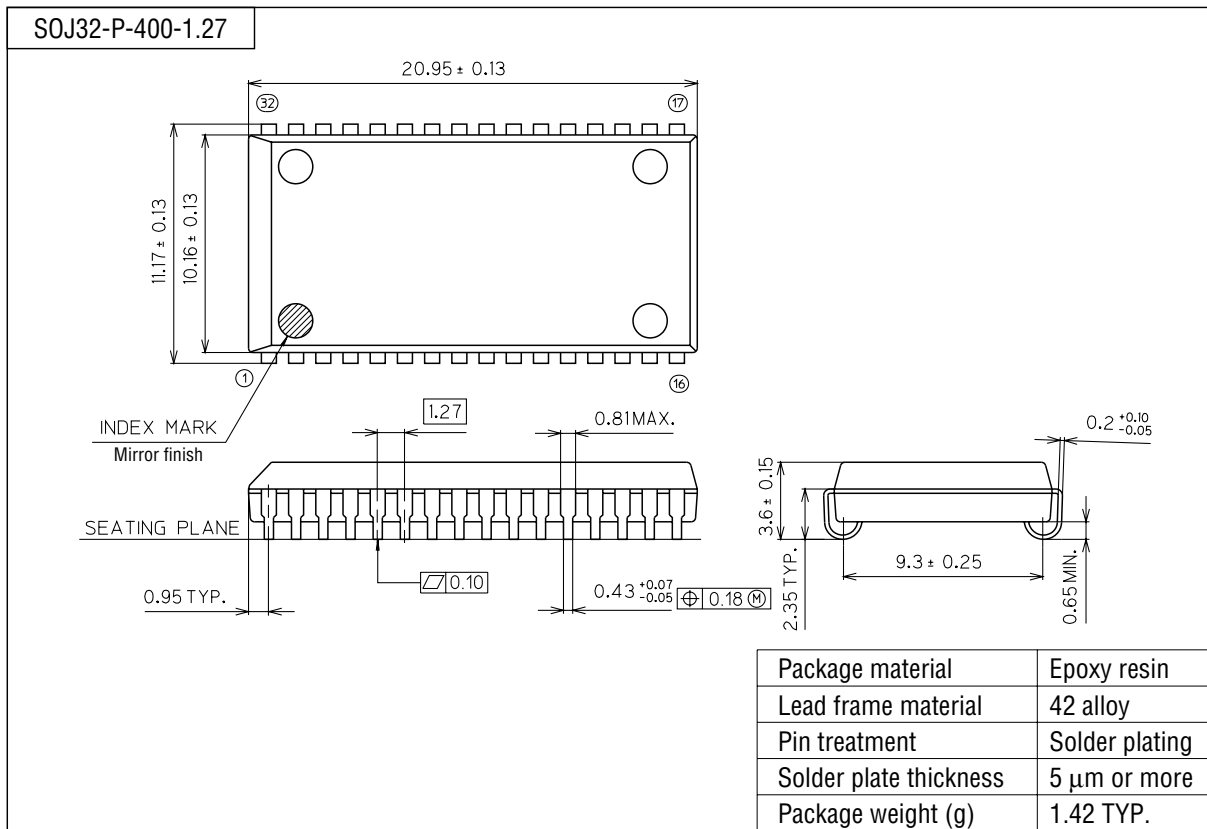

Notes for Mounting the Surface Mount Type Package

The SOP, QFP, TSOP, SOJ, QFJ (PLCC), SHP and BGA are surface mount type packages, which are very susceptible to heat in reflow mounting and humidity absorbed in storage. Therefore, before you perform reflow mounting, contact Oki's responsible sales person for the product name, package name, pin number, package code and desired mounting conditions (reflow method, temperature and times).