

S25FL064A

64 Megabit CMOS 3.0 Volt Flash Memory
with 50-MHz SPI (Serial Peripheral Interface) Bus

Data Sheet



Notice to Readers: This document states the current technical specifications regarding the Spansion product(s) described herein. Spansion Inc. deems the products to have been in sufficient production volume such that subsequent versions of this document are not expected to change. However, typographical or specification corrections, or modifications to the valid combinations offered may occur.

Notice On Data Sheet Designations

Spansion Inc. issues data sheets with Advance Information or Preliminary designations to advise readers of product information or intended specifications throughout the product life cycle, including development, qualification, initial production, and full production. In all cases, however, readers are encouraged to verify that they have the latest information before finalizing their design. The following descriptions of Spansion data sheet designations are presented here to highlight their presence and definitions.

Advance Information

The Advance Information designation indicates that Spansion Inc. is developing one or more specific products, but has not committed any design to production. Information presented in a document with this designation is likely to change, and in some cases, development on the product may discontinue. Spansion Inc. therefore places the following conditions upon Advance Information content:

“This document contains information on one or more products under development at Spansion Inc. The information is intended to help you evaluate this product. Do not design in this product without contacting the factory. Spansion Inc. reserves the right to change or discontinue work on this proposed product without notice.”

Preliminary

The Preliminary designation indicates that the product development has progressed such that a commitment to production has taken place. This designation covers several aspects of the product life cycle, including product qualification, initial production, and the subsequent phases in the manufacturing process that occur before full production is achieved. Changes to the technical specifications presented in a Preliminary document should be expected while keeping these aspects of production under consideration. Spansion places the following conditions upon Preliminary content:

“This document states the current technical specifications regarding the Spansion product(s) described herein. The Preliminary status of this document indicates that product qualification has been completed, and that initial production has begun. Due to the phases of the manufacturing process that require maintaining efficiency and quality, this document may be revised by subsequent versions or modifications due to changes in technical specifications.”

Combination

Some data sheets contain a combination of products with different designations (Advance Information, Preliminary, or Full Production). This type of document distinguishes these products and their designations wherever necessary, typically on the first page, the ordering information page, and pages with the DC Characteristics table and the AC Erase and Program table (in the table notes). The disclaimer on the first page refers the reader to the notice on this page.

Full Production (No Designation on Document)

When a product has been in production for a period of time such that no changes or only nominal changes are expected, the Preliminary designation is removed from the data sheet. Nominal changes may include those affecting the number of ordering part numbers available, such as the addition or deletion of a speed option, temperature range, package type, or V_{IO} range. Changes may also include those needed to clarify a description or to correct a typographical error or incorrect specification. Spansion Inc. applies the following conditions to documents in this category:

“This document states the current technical specifications regarding the Spansion product(s) described herein. Spansion Inc. deems the products to have been in sufficient production volume such that subsequent versions of this document are not expected to change. However, typographical or specification corrections, or modifications to the valid combinations offered may occur.”

Questions regarding these document designations may be directed to your local sales office.

S25FL064A

64 Megabit CMOS 3.0 Volt Flash Memory with 50-MHz SPI (Serial Peripheral Interface) Bus



Data Sheet

Distinctive Characteristics

Architectural Advantages

- **Single power supply operation**
 - Full voltage range: 2.7 to 3.6 V read and program operations
- **Memory Architecture**
 - 128 sectors with 512 Kb each
- **Program**
 - Page Program (up to 256 bytes) in 1.5 ms (typical)
 - Program operations are on a page by page basis
- **Erase**
 - 1.5 s typical sector erase time
 - Bulk erase command
- **Cycling Endurance**
 - 100,000 cycles per sector typical
- **Data Retention**
 - 20 years typical
- **Device ID**
 - JEDEC standard two-byte electronic signature
 - RES command one-byte electronic signature for backward compatibility

Process Technology

- Manufactured on 0.20 μm MirrorBit® process technology

Package Option

- Industry Standard Pinouts
- 16-pin SO package (300 mils)

Performance Characteristics

- **Speed**
 - 50 MHz clock rate (maximum)
- **Power Saving Standby Mode**
 - Standby Mode 50 μA (max)
 - Deep Power Down Mode 1 μA (typical)

Memory Protection Features

- **Memory Protection**
 - W# pin works in conjunction with Status Register Bits to protect specified memory areas
 - Status Register Block Protection bits (BP2, BP1, BP0) in status register configure parts of memory as read-only

Software Features

- SPI Bus Compatible Serial Interface

General Description

The S25FL064A is a 3.0 Volt (2.7 V to 3.6 V), single-power-supply Flash memory device. The device consists of 128 sectors, each with 512 Kb memory.

The device accepts data written to SI (Serial Input) and outputs data on SO (Serial Output). The devices are designed to be programmed in-system with the standard system 3.0 volt V_{CC} supply.

The memory can be programmed 1 to 256 bytes at a time, using the Page Program command. The device supports Sector Erase and Bulk Erase commands.

Each device requires only a 3.0 volt power supply (2.7 V to 3.6 V) for both read and write functions. Internally generated and regulated voltages are provided for the program operations. This device does not require a V_{PP} supply.

Table of Contents

Distinctive Characteristics	3
General Description	4
1. Block Diagram	8
2. Connection Diagrams	8
3. Input/Output Descriptions	9
4. Logic Symbol	9
5. Ordering Information	10
5.1 Valid Combinations	10
6. Spansion SPI Modes	11
7. Device Operations	12
7.1 Byte or Page Programming	12
7.2 Sector Erase / Bulk Erase	12
7.3 Monitoring Write Operations Using the Status Register	12
7.4 Active Power and Standby Power Modes	12
7.5 Status Register	12
7.6 Data Protection Modes	13
7.7 Hold Mode (HOLD#)	14
8. Sector Address Table	14
9. Command Definitions	16
9.1 Read Data Bytes (READ)	16
9.2 Read Data Bytes at Higher Speed (FAST_READ)	17
9.3 Read Identification (RDID)	18
9.4 Write Enable (WREN)	19
9.5 Write Disable (WRDI)	19
9.6 Read Status Register (RDSR)	20
9.7 Write Status Register (WRSR)	21
9.8 Page Program (PP)	23
9.9 Sector Erase (SE)	24
9.10 Bulk Erase (BE)	25
9.11 Deep Power Down (DP)	26
9.12 Release from Deep Power Down (RES)	27
10. Power-up and Power-down	29
11. Initial Delivery State	29
12. Absolute Maximum Ratings	30
13. Operating Ranges	30
14. DC Characteristics	31
15. Test Conditions	31
16. AC Characteristics	32
17. Physical Dimensions	35
17.1 SO3 016 wide—16-pin Plastic Small Outline Package (300-mil Body Width)	35
18. Revision History	36

Figures

Figure 2.1	16-pin Plastic Small Outline Package (SO)	8
Figure 6.1	Bus Master and Memory Devices on the SPI Bus	11
Figure 6.2	SPI Modes Supported	11
Figure 7.1	Hold Mode Operation	14
Figure 9.1	Read Data Bytes (READ) Command Sequence	16
Figure 9.2	Read Data Bytes at Higher Speed (FAST_READ) Command Sequence	17
Figure 9.3	Read Identification (RDID) Command Sequence and Data-Out Sequence	18
Figure 9.4	Write Enable (WREN) Command Sequence	19
Figure 9.5	Write Disable (WRDI) Command Sequence	19
Figure 9.6	Read Status Register (RDSR) Command Sequence	20
Figure 9.7	Write Status Register (WRSR) Command Sequence	21
Figure 9.8	Page Program (PP) Command Sequence	23
Figure 9.9	Sector Erase (SE) Command Sequence	24
Figure 9.10	Bulk Erase (BE) Command Sequence	25
Figure 9.11	Deep Power Down (DP) Command Sequence	26
Figure 9.12	Release from Deep Power Down (RES) Command Sequence	27
Figure 9.13	Release from Deep Power Down and Read Electronic Signature (RES) Command Sequence	28
Figure 10.1	Power-Up Timing Diagram	29
Figure 12.1	Maximum Negative Overshoot Waveform	30
Figure 12.2	Maximum Positive Overshoot Waveform	30
Figure 15.1	AC Measurements I/O Waveform	31
Figure 16.1	SPI Mode 0 (0,0) Input Timing	33
Figure 16.2	SPI Mode 0 (0,0) Output Timing	33
Figure 16.3	HOLD# Timing	33
Figure 16.4	Write Protect Setup and Hold Timing during WRSR when SRWD=1	34

Tables

Table 5.1	S25FL064A Valid Combinations Table	10
Table 7.1	S25FL064A Protected Area Sizes	13
Table 8.1	S25FL064A Device Organization	14
Table 8.2	S25FL064A Sector Address Table	15
Table 9.1	Read Identification (RDID) Data-Out Sequence	18
Table 9.2	S25FL064A Status Register	20
Table 9.3	Protection Modes	22
Table 9.4	Command Definitions	28
Table 10.1	Power-Up Timing Characteristics	29
Table 12.1	Absolute Maximum Ratings	30
Table 13.1	Operating Ranges	30
Table 14.1	DC Characteristics (CMOS Compatible)	31
Table 15.1	Test Specifications	31
Table 16.1	AC Characteristics	32

1. Block Diagram

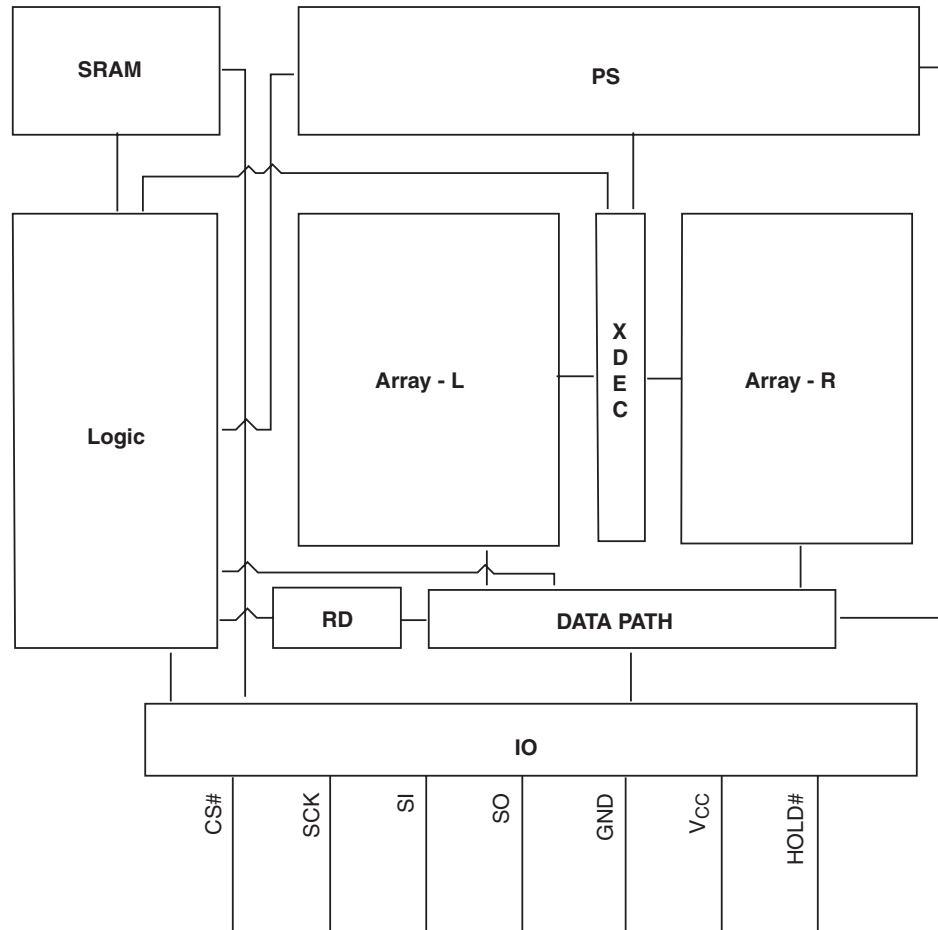

2. Connection Diagrams

Figure 2.1 16-pin Plastic Small Outline Package (SO)

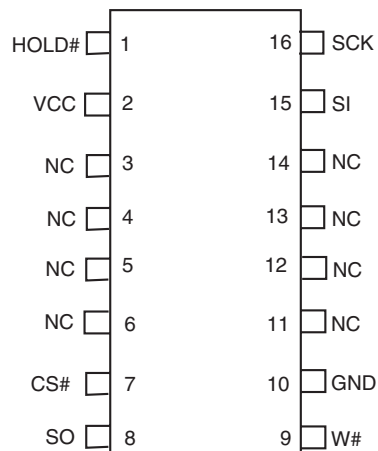

3. Input/Output Descriptions

Signal	I/O	Description
SO	Output	Signal Data Output: Transfers data serially out of the device on the falling edge of SCK.
SI	Input	Serial Data Input: Transfers data serially into the device. Device latches commands, addresses, and program data on SI on the rising edge of SCK.
SCK	Input	Serial Clock: Provides serial interface timing. Latches commands, addresses, and data on SI on rising edge of SCK. Triggers output on SO after the falling edge of SCK.
CS#	Input	Chip Select: Places device in active power mode when driven low. Deselects device and places SO at high impedance when high. After power-up, device requires a falling edge on CS# before any command is written. Device is in standby mode when a program, erase, or Write Status Register operation is not in progress.
HOLD#	Input	Hold: Pauses any serial communication with the device without deselecting it. When driven low, SO is at high impedance, and all input at SI and SCK are ignored. Requires that CS# also be driven low.
W#	Input	Write Protect: Protects the memory area specified by Status Register bits BP2:BP0. When driven low, prevents any program or erase command from altering the data in the protected memory area.
V _{CC}	Input	Supply Voltage
GND	Input	Ground

4. Logic Symbol

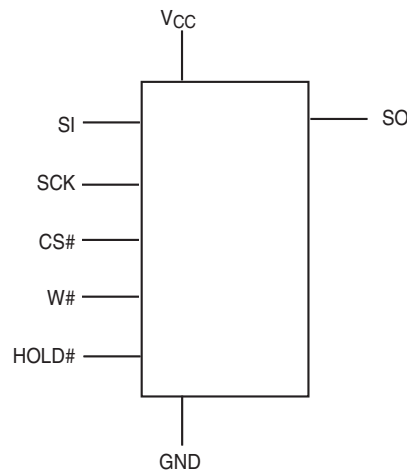

5. Ordering Information

The ordering part number is formed by a valid combination of the following:

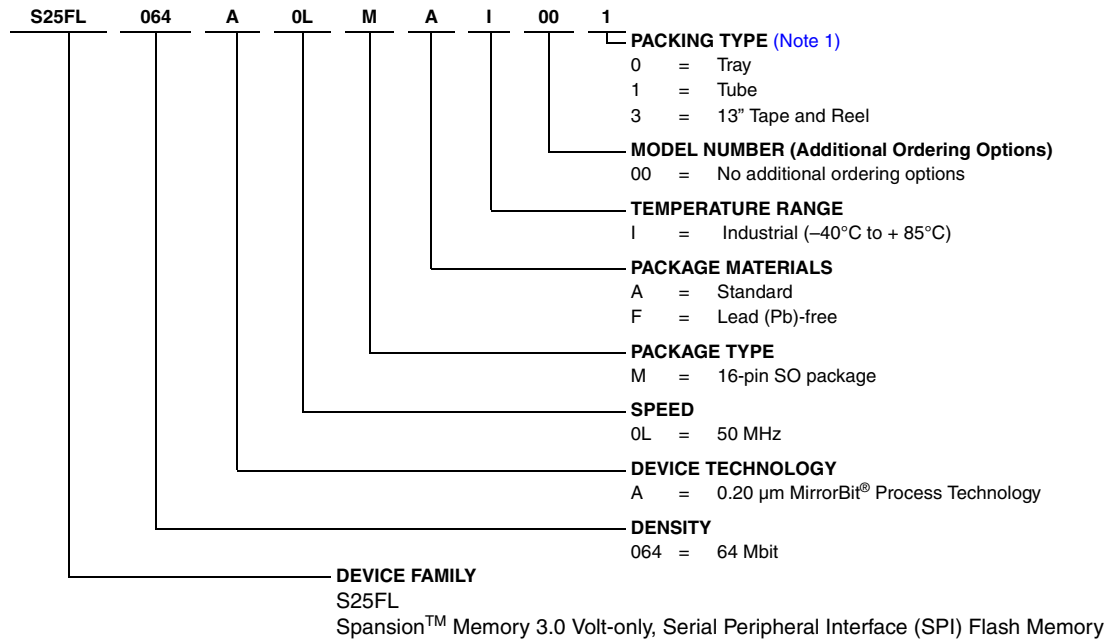

Table 5.1 S25FL064A Valid Combinations Table

S25FL064A Valid Combinations					Package Marking (Note 2)
Base Ordering Part Number	Speed Option	Package & Temperature	Model Number	Packing Type	
S25FL064A	0L	MAI, MFI, NAI, NFI	00	0, 1, 3 (Note 1)	FL064A + (Temp) + (Note 3)

Notes

1. Contact your local sales office for availability.
2. Package marking omits leading "S25" and speed, package, and model number form.
3. A for standard package (non-Pb free); F for Pb-free package.

5.1 Valid Combinations

Table 5.1 lists the valid combinations configurations planned to be supported in volume for this device.

6. Spansion SPI Modes

A microcontroller can use either of its two SPI modes to control Spansion SPI Flash memory devices:

- CPOL = 0, CPHA = 0 (Mode 0)
- CPOL = 1, CPHA = 1 (Mode 3)

Input data is latched in on the rising edge of SCK, and output data is available from the falling edge of SCK for both modes.

When the bus master is in standby mode, SCK is as shown in [Figure 6.2](#) for each of the two modes:

- SCK remains at 0 for (CPOL = 0, CPHA = 0 Mode 0)
- SCK remains at 1 for (CPOL = 1, CPHA = 1 Mode 3)

Figure 6.1 Bus Master and Memory Devices on the SPI Bus

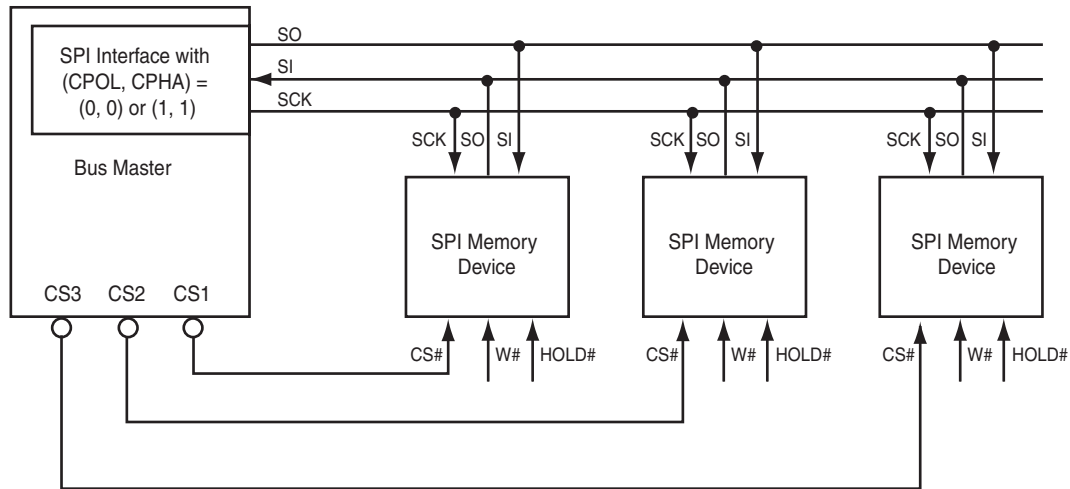

Note
The Write Protect (W#) and Hold (HOLD#) signals should be driven high (logic level 1) or low (logic level 0) as appropriate.

Figure 6.2 SPI Modes Supported

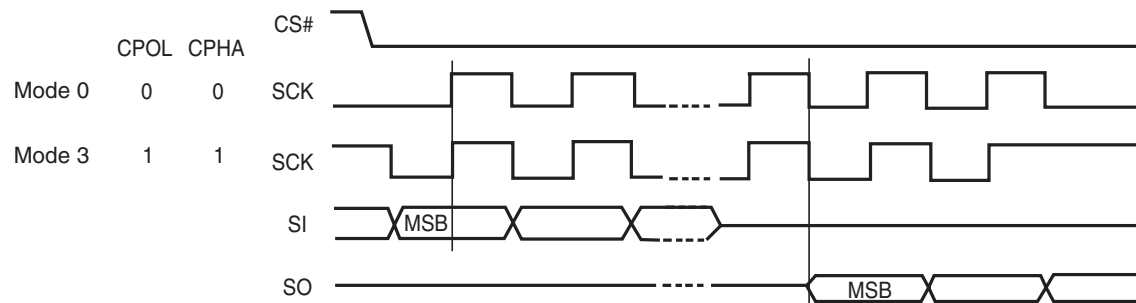

7. Device Operations

All Spansion SPI devices (S25FL-A) accept and output data in bytes (8 bits at a time).

7.1 Byte or Page Programming

Programming data requires two commands: Write Enable (WREN), which is one byte, and a Page Program (PP) sequence, which consists of four bytes plus data. The Page Program sequence accepts from 1 byte up to 256 consecutive bytes of data (which is the size of one page) to be programmed in one operation. Programming means that bits can either be left at 0, or programmed from 1 to 0. Changing bits from 0 to 1 requires an erase operation. Before this can be applied, the bytes of the memory need to be first erased to all 1's (FFh) before any programming.

7.2 Sector Erase / Bulk Erase

The Sector Erase (SE) and Bulk Erase (BE) commands set all the bits in a sector or the entire memory array to 1. While bits can be individually programmed from a 1 to 0, erasing bits from 0 to 1 must be done on a sector-wide (SE) or array-wide (BE) level.

7.3 Monitoring Write Operations Using the Status Register

The host system can determine when a Write Status Register, program, or erase operation is complete by monitoring the Write in Progress (WIP) bit in the Status Register. The Read from Status Register command provides the state of the WIP bit.

7.4 Active Power and Standby Power Modes

The device is enabled and in the Active Power mode when Chip Select (CS#) is Low. When CS# is high, the device is disabled, but may still be in the Active Power mode until all program, erase, and Write Status Register operations have completed. The device then goes into the Standby Power mode, and power consumption drops to I_{SB} . The Deep Power Down (DP) command provides additional data protection against inadvertent signals. After writing the DP command, the device ignores any further program or erase commands, and reduces its power consumption to I_{DP} .

7.5 Status Register

The Status Register contains the status and control bits that can be read or set by specific commands ([Table 9.2, S25FL064A Status Register on page 20](#)):

- **Write In Progress (WIP):** Indicates whether the device is performing a Write Status Register, program or erase operation.
- **Write Enable Latch (WEL):** Indicates the status of the internal Write Enable Latch.
- **Block Protect (BP2, BP1, BP0):** Non-volatile bits that define memory area to be software-protected against program and erase commands.
- **Status Register Write Disable (SRWD):** Places the device in the Hardware Protected mode when this bit is set to 1 and the W# input is driven low. In this mode, the non-volatile bits of the Status Register (SRWD, BP2, BP1, BP0) become read-only bits.

7.6 Data Protection Modes

Spansion SPI Flash memory devices provide the following data protection methods:

- **The Write Enable (WREN) command:** Must be written prior to any command that modifies data. The WREN command sets the Write Enable Latch (WEL) bit. The WEL bit resets (disables writes) on *power-up* or after the device completes the following *commands*:
 - Page Program (PP)
 - Sector Erase (SE)
 - Bulk Erase (BE)
 - Write Disable (WRDI)
 - Write Status Register (WRSR)
- **Software Protected Mode (SPM):** The Block Protect (BP2, BP1, BP0) bits define the section of the memory array that can be read but not programmed or erased. [Table 7.1](#) shows the sizes and address ranges of protected areas that are defined by Status Register bits BP2:BP0.
- **Hardware Protected Mode (HPM):** The Write Protect (W#) input and the Status Register Write Disable (SRWD) bit together provide write protection.
- **Clock Pulse Count:** The device verifies that all program, erase, and Write Status Register commands consist of a clock pulse count that is a multiple of eight before executing them.

Table 7.1 S25FL064A Protected Area Sizes

Status Register Block Protect Bits			Memory Array				Protected Portion of Total Memory Area
BP2	BP1	BP0	Protected Address Range	Protected Sectors	Unprotected Address Range	Unprotected Sectors	
0	0	0	None	(0)	000000h–7FFFFFFh	SA127:SA0	0
0	0	1	7E0000h–7FFFFFFh	(2) SA127:SA126	000000h–7DFFFFFFh	SA125:SA0	1/64
0	1	0	7C0000h–7FFFFFFh	(4) SA127:SA124	000000h–7BFFFFFFh	SA123:SA0	1/32
0	1	1	780000h–7FFFFFFh	(8) SA127:SA120	000000h–77FFFFFFh	SA119:SA0	1/16
1	0	0	700000h–7FFFFFFh	(16) SA127:SA112	000000h–6FFFFFFh	SA111:SA0	1/8
1	0	1	600000h–7FFFFFFh	(32) SA127:SA96	000000h–5FFFFFFh	SA95:SA0	1/4
1	1	0	400000h–7FFFFFFh	(64) SA127:SA64	000000h–3FFFFFFh	SA63:SA0	1/2
1	1	1	000000h–7FFFFFFh	(128) SA127:SA0	None	None	All

7.7 Hold Mode (HOLD#)

The Hold input (HOLD#) stops any serial communication with the device, but does not terminate any Write Status Register, program or erase operation that is currently in progress.

The Hold mode starts on the falling edge of HOLD# if SCK is also low (see [Figure 7.1](#), standard use). If the falling edge of HOLD# does not occur while SCK is low, the Hold mode begins after the next falling edge of SCK (non-standard use).

The Hold mode ends on the rising edge of HOLD# signal (standard use) if SCK is also low. If the rising edge of HOLD# does not occur while SCK is low, the Hold mode ends on the next falling edge of CLK (non-standard use) See [Figure 7.1](#).

The SO output is high impedance, and the SI and SCK inputs are ignored (don't care) for the duration of the Hold mode.

CS# must remain low for the entire duration of the Hold mode to ensure that the device internal logic remains unchanged. If CS# goes high while the device is in the Hold mode, the internal logic is reset. To prevent the device from reverting to the Hold mode when device communication is resumed, HOLD# must be held high, followed by driving CS# low.

Figure 7.1 Hold Mode Operation

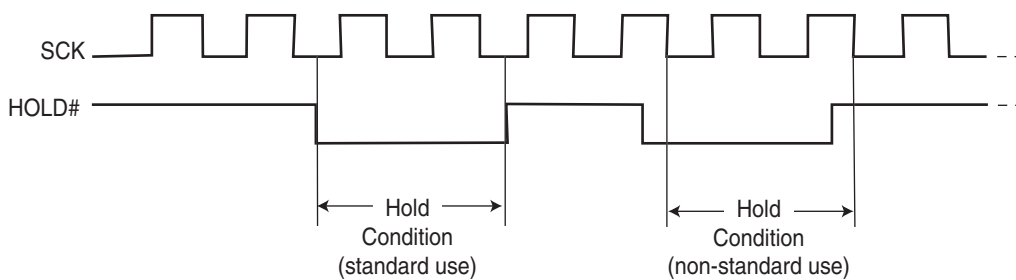

8. Sector Address Table

[Table 8.1](#) shows the size of the memory array, sectors, and pages. The device uses *pages* to cache the program data before the data is programmed into the memory array. Each page or byte can be individually programmed (bits are changed from 1 to 0). The data is erased (bits are changed from 0 to 1) on a sector- or device-wide basis using the SE or BE commands. [Table 8.2 on page 15](#) shows the starting and ending address for each sector. The complete set of sectors comprises the memory array of the Flash device.

Table 8.1 S25FL064A Device Organization

Each Device has	Each Sector has	Each Page has	
8,388,608	65,536	256	bytes
32,768	256	—	pages
128	—	—	sectors

Table 8.2 S25FL064A Sector Address Table

Sector	Address Range		Sector	Address Range		Sector	Address Range	
SA127	7F0000h	7FFFFFFh	SA84	540000h	54FFFFFFh	SA41	290000h	29FFFFFFh
SA126	7E0000h	7EFFFFFFh	SA83	530000h	53FFFFFFh	SA40	280000h	28FFFFFFh
SA125	7D0000h	7DFFFFFFh	SA82	520000h	52FFFFFFh	SA39	270000h	27FFFFFFh
SA124	7C0000h	7CFFFFFFh	SA81	510000h	51FFFFFFh	SA38	260000h	26FFFFFFh
SA123	7B0000h	7BFFFFFFh	SA80	500000h	50FFFFFFh	SA37	250000h	25FFFFFFh
SA122	7A0000h	7AFFFFFFh	SA79	4F0000h	4FFFFFFh	SA36	240000h	24FFFFFFh
SA121	790000h	79FFFFFFh	SA78	4E0000h	4EFFFFFFh	SA35	230000h	23FFFFFFh
SA120	780000h	78FFFFFFh	SA77	4D0000h	4DFFFFFFh	SA34	220000h	22FFFFFFh
SA119	770000h	77FFFFFFh	SA76	4C0000h	4CFFFFFFh	SA33	210000h	21FFFFFFh
SA118	760000h	76FFFFFFh	SA75	4B0000h	4BFFFFFFh	SA32	200000h	20FFFFFFh
SA117	750000h	75FFFFFFh	SA74	4A0000h	4AFFFFFFh	SA31	1F0000h	1FFFFFFh
SA116	740000h	74FFFFFFh	SA73	490000h	49FFFFFFh	SA30	1E0000h	1EFFFFFFh
SA115	730000h	73FFFFFFh	SA72	480000h	48FFFFFFh	SA29	1D0000h	1DFFFFFFh
SA114	720000h	72FFFFFFh	SA71	470000h	47FFFFFFh	SA28	1C0000h	1CFFFFFFh
SA113	710000h	71FFFFFFh	SA70	460000h	46FFFFFFh	SA27	1B0000h	1BFFFFFFh
SA112	700000h	70FFFFFFh	SA69	450000h	45FFFFFFh	SA26	1A0000h	1AFFFFFFh
SA111	6F0000h	6FFFFFFh	SA68	440000h	44FFFFFFh	SA25	190000h	19FFFFFFh
SA110	6E0000h	6EFFFFFFh	SA67	430000h	43FFFFFFh	SA24	180000h	18FFFFFFh
SA109	6D0000h	6DFFFFFFh	SA66	420000h	42FFFFFFh	SA23	170000h	17FFFFFFh
SA108	6C0000h	6CFFFFFFh	SA65	410000h	41FFFFFFh	SA22	160000h	16FFFFFFh
SA107	6B0000h	6BFFFFFFh	SA64	400000h	40FFFFFFh	SA21	150000h	15FFFFFFh
SA106	6A0000h	6AFFFFFFh	SA63	3F0000h	3FFFFFFh	SA20	140000h	14FFFFFFh
SA105	690000h	69FFFFFFh	SA62	3E0000h	3EFFFFFFh	SA19	130000h	13FFFFFFh
SA104	680000h	68FFFFFFh	SA61	3D0000h	3DFFFFFFh	SA18	120000h	12FFFFFFh
SA103	670000h	67FFFFFFh	SA60	3C0000h	3CFFFFFFh	SA17	110000h	11FFFFFFh
SA102	660000h	66FFFFFFh	SA59	3B0000h	3BFFFFFFh	SA16	100000h	10FFFFFFh
SA101	650000h	65FFFFFFh	SA58	3A0000h	3AFFFFFFh	SA15	0F0000h	0FFFFFFh
SA100	640000h	64FFFFFFh	SA57	390000h	39FFFFFFh	SA14	0E0000h	0EFFFFFFh
SA99	630000h	63FFFFFFh	SA56	380000h	38FFFFFFh	SA13	0D0000h	0DFFFFFFh
SA98	620000h	62FFFFFFh	SA55	370000h	37FFFFFFh	SA12	0C0000h	0CFFFFFFh
SA97	610000h	61FFFFFFh	SA54	360000h	36FFFFFFh	SA11	0B0000h	0BFFFFFFh
SA96	600000h	60FFFFFFh	SA53	350000h	35FFFFFFh	SA10	0A0000h	0AFFFFFFh
SA95	5F0000h	5FFFFFFh	SA52	340000h	34FFFFFFh	SA9	090000h	09FFFFFFh
SA94	5E0000h	5EFFFFFFh	SA51	330000h	33FFFFFFh	SA8	080000h	08FFFFFFh
SA93	5D0000h	5DFFFFFFh	SA50	320000h	32FFFFFFh	SA7	070000h	07FFFFFFh
SA92	5C0000h	5CFFFFFFh	SA49	310000h	31FFFFFFh	SA6	060000h	06FFFFFFh
SA91	5B0000h	5BFFFFFFh	SA48	300000h	30FFFFFFh	SA5	050000h	05FFFFFFh
SA90	5A0000h	5AFFFFFFh	SA47	2F0000h	2FFFFFFh	SA4	040000h	04FFFFFFh
SA89	590000h	59FFFFFFh	SA46	2E0000h	2EFFFFFFh	SA3	030000h	03FFFFFFh
SA88	580000h	58FFFFFFh	SA45	2D0000h	2DFFFFFFh	SA2	020000h	02FFFFFFh
SA87	570000h	57FFFFFFh	SA44	2C0000h	2CFFFFFFh	SA1	010000h	01FFFFFFh
SA86	560000h	56FFFFFFh	SA43	2B0000h	2BFFFFFFh	SA0	000000h	00FFFFFFh
SA85	550000h	55FFFFFFh	SA42	2A0000h	2AFFFFFFh			

9. Command Definitions

The host system must shift all commands, addresses, and data in and out of the device, beginning with the most significant bit. On the first rising edge of SCK after CS# is driven low, the device accepts the one-byte command on SI (all commands are one byte long), most significant bit first. Each successive bit is latched on the rising edge of SCK. [Table 9.4 on page 28](#) lists the complete set of commands.

Every command sequence begins with a one-byte command code. The command may be followed by address, data, both, or nothing, depending on the command. CS# must be driven high after the last bit of the command sequence has been written.

The Read Data Bytes (READ), Read Status Register (RDSR), Read Data Bytes at Higher Speed (FAST_READ) and Read Identification (RDID) command sequences are followed by a data output sequence on SO. CS# can be driven high after any bit of the sequence is output to terminate the operation.

The Page Program (PP), Sector Erase (SE), Bulk Erase (BE), Write Status Register (WRSR), Write Enable (WREN), or Write Disable (WRDI) commands require that CS# be driven high at a byte boundary, otherwise the command is not executed. Since a byte is composed of eight bits, CS# must therefore be driven high when the number of clock pulses after CS# is driven low is an exact multiple of eight.

The device ignores any attempt to access the memory array during a Write Status Register, program, or erase operation, and continues the operation uninterrupted.

9.1 Read Data Bytes (READ)

The Read Data Bytes (READ) command reads data from the memory array at the frequency (f_{SCK}) presented at the SCK input, with a maximum speed of 33 MHz. The host system must first select the device by driving CS# low. The READ command is then written to SI, followed by a 3-byte address (A23-A0). Each bit is latched on the rising edge of SCK. The memory array data, at that address, are output serially on SO at a frequency f_{SCK} , on the falling edge of SCK.

[Figure 9.1](#) and [Table 9.4 on page 28](#) detail the READ command sequence. The first byte specified can be at any location. The device automatically increments to the next higher address after each byte of data is output. The entire memory array can therefore be read with a single READ command. When the highest address is reached, the address counter reverts to 00000h, allowing the read sequence to continue indefinitely.

The READ command is terminated by driving CS# high at any time during data output. The device rejects any READ command issued while it is executing a program, erase, or Write Status Register operation, and continues the operation uninterrupted.

Figure 9.1 Read Data Bytes (READ) Command Sequence

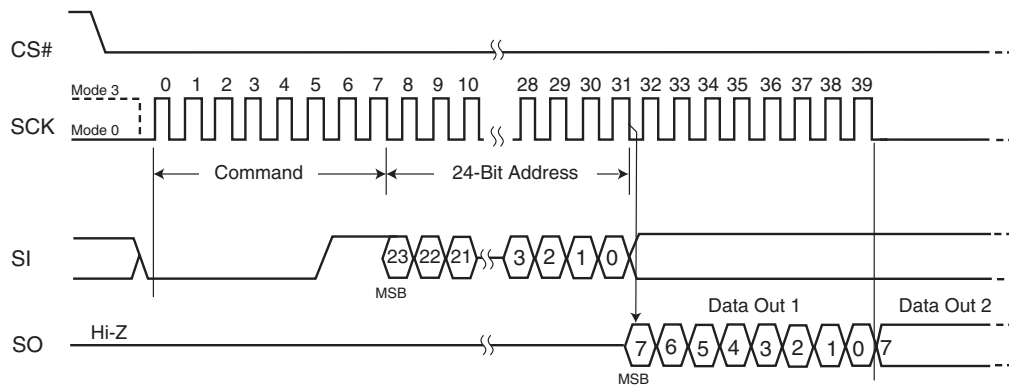

9.2 Read Data Bytes at Higher Speed (FAST_READ)

The FAST_READ command reads data from the memory array at the frequency (f_{SCK}) presented at the SCK input, with a maximum speed of 50 MHz. The host system must first select the device by driving CS# low. The FAST_READ command is then written to SI, followed by a 3-byte address (A23-A0) and a dummy byte. Each bit is latched on the rising edge of SCK. The memory array data, at that address, are output serially on SO at a frequency f_{SCK} , on the falling edge of SCK.

The FAST_READ command sequence is shown in Figure 9.2 and Table 9.4 on page 28. The first byte specified can be at any location. The device automatically increments to the next higher address after each byte of data is output. The entire memory array can therefore be read with a single FAST_READ command. When the highest address is reached, the address counter reverts to 00000h, allowing the read sequence to continue indefinitely.

The FAST_READ command is terminated by driving CS# high at any time during data output. The device rejects any FAST_READ command issued while it is executing a program, erase, or Write Status Register operation, and continues the operation uninterrupted.

Figure 9.2 Read Data Bytes at Higher Speed (FAST_READ) Command Sequence

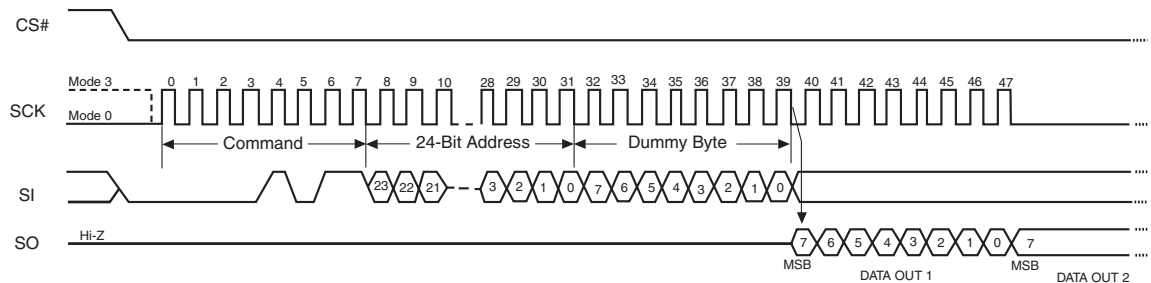

9.3 Read Identification (RDID)

The Read Identification (RDID) command outputs the one-byte manufacturer identification, followed by the two-byte device identification, to the host system.

JEDEC assigns the manufacturer identification byte; for Spansion devices it is 01h. The device manufacturer assigns the device identification: the first byte provides the memory type; the second byte indicates the memory capacity. See [Table 9.1 on page 18](#) or [Table 9.4 on page 28](#) for device ID data.

The host system must first select the device by driving CS# low. The RDID command is then written to SI, and each bit is latched on the rising edge of SCK. The 24-bit device identification data is output from the memory array on SO at a frequency f_{SCK} , on the falling edge of SCK.

The RDID command sequence is shown in [Figure 9.3](#) and [Table 9.4 on page 28](#).

Driving CS# high after the device identification data has been read at least once terminates the READ_ID command. Driving CS# high at any time during data output also terminates the RDID operation.

The device rejects any RDID command issued while it is executing a program, erase, or Write Status Register operation, and continues the operation uninterrupted.

Figure 9.3 Read Identification (RDID) Command Sequence and Data-Out Sequence

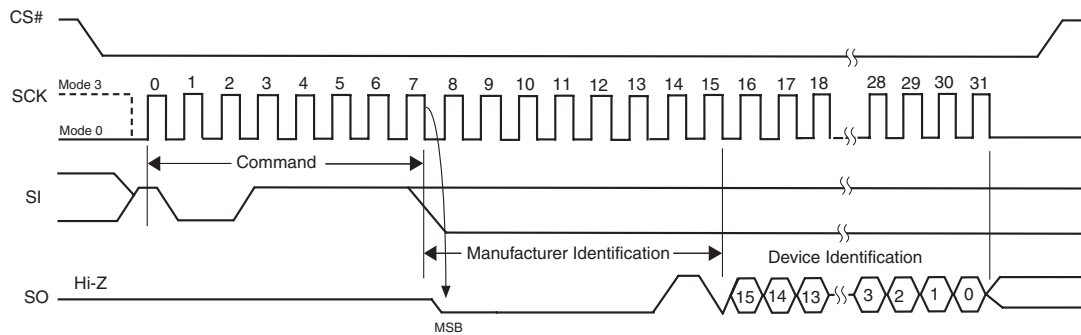

Table 9.1 Read Identification (RDID) Data-Out Sequence

Manufacturer Identification	Device Identification	
	Memory Type	Memory Capacity
01h	02h	16h

9.4 Write Enable (WREN)

The Write Enable (WREN) command (see [Figure 9.4](#)) sets the Write Enable Latch (WEL) bit to a 1, which enables the device to accept a Write Status Register, program, or erase command. The WEL bit must be set prior to every Page Program (PP), Erase (SE or BE) and Write Status Register (WRSR) command.

The host system must first drive CS# low, write the WREN command, and then drive CS# high.

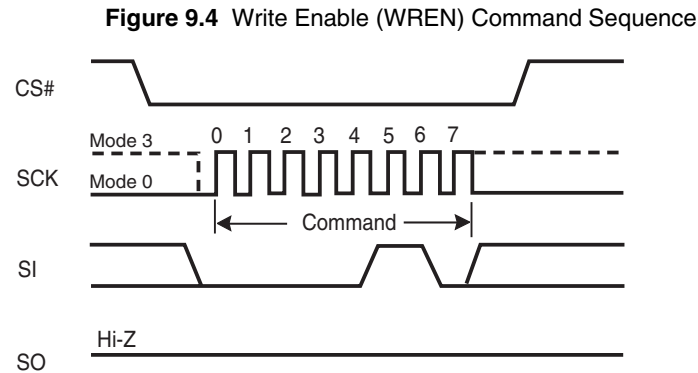

9.5 Write Disable (WRDI)

The Write Disable (WRDI) command (see [Figure 9.5](#)) resets the Write Enable Latch (WEL) bit to a 0, which disables the device from accepting a Write Status Register, program, or erase command. The host system must first drive CS# low, write the WRDI command, and then drive CS# high.

Any of following conditions resets the WEL bit:

- Power-up
- Write Disable (WRDI) command completion
- Write Status Register (WRSR) command completion
- Page Program (PP) command completion
- Sector Erase (SE) command completion
- Bulk Erase (BE) command completion

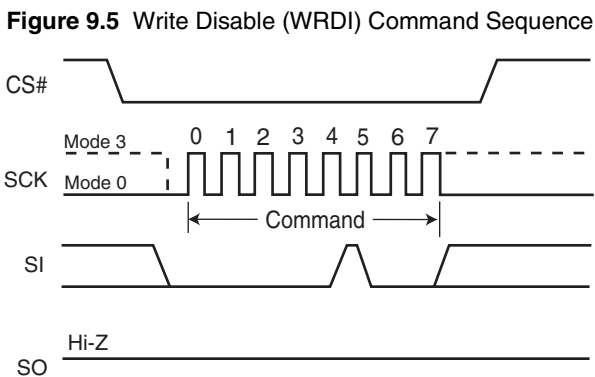

9.6 Read Status Register (RDSR)

The Read Status Register (RDSR) command outputs the state of the Status Register bits. [Table 9.2](#) shows the status register bits and their functions.

The RDSR command may be written at any time, even while a program, erase, or Write Status Register operation is in progress. The host system should check the Write In Progress (WIP) bit before sending a new command to the device if an operation is already in progress. [Figure 9.6](#) shows the RDSR command sequence, which also shows that it is possible to read the Status Register continuously until CS# is driven high.

Table 9.2 S25FL064A Status Register

Bit	Status Register Bit	Bit Function	Description
7	SRWD	Status Register Write Disable	1 = Protects when W# is low 0 = No protection, even when W# is low
6	—	—	Not used
5	—	—	Not used
4	BP2	Block Protect	000–111 = Protects upper half of address range in 5 sizes. See Table 7.1 on page 13 .
3	BP1		
2	BP0		
1	WEL	Write Enable Latch	1 = Device accepts Write Status Register, program, or erase commands 0 = Ignores Write Status Register, program, or erase commands
0	WIP	Write in Progress	1 = Device Busy. A Write Status Register, program, or erase operation is in progress 0 = Ready. Device is in standby mode and can accept commands.

Figure 9.6 Read Status Register (RDSR) Command Sequence

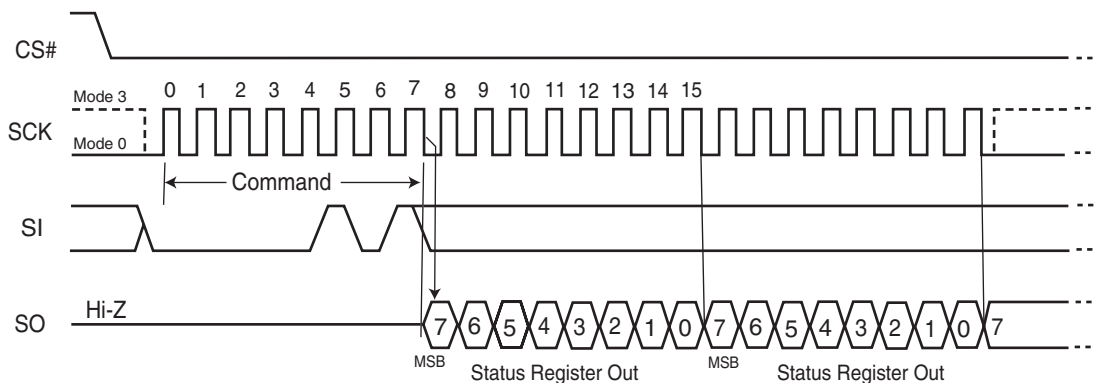

The following describes the status and control bits of the Status Register.

Write In Progress (WIP) bit: Indicates whether the device is busy performing a Write Status Register, program, or erase operation. This bit is read-only, and is controlled internally by the device. If WIP is 1, one of these operations is in progress; if WIP is 0, no such operation is in progress.

Write Enable Latch (WEL) bit: Determines whether the device will accept and execute a Write Status Register, program, or erase command. When set to 1, the device accepts these commands; when set to 0, the device rejects the commands. This bit is set to 1 by writing the WREN command, and set to 0 by the WRDI command, and is also automatically reset to 0 after the completion of a Write Status Register, program, or erase operation. WEL cannot be directly set by the WRSR command.

Block Protect (BP2, BP1, BP0) bits: Define the portion of the memory area that will be protected against any changes to the stored data. The Write Status Register (WRSR) command controls these bits, which are non-volatile. When one or more of these bits is set to 1, the corresponding memory area (see [Table 7.1 on page 13](#)) is protected against Page Program (PP) and Sector Erase (SE) commands. If the Hardware Protected mode is enabled, BP2:BP0 cannot be changed. The Bulk Erase (BE) command is executed only if all Block Protect (BP2, BP1, BP0) bits are 0.

Status Register Write Disable (SRWD) bit: Provides data protection when used together with the Write Protect (W#) signal. When SRWD is set to 1 and W# is driven low, the device enters the Hardware Protected mode. The non-volatile bits of the Status Register (SRWD, BP2, BP1, BP0) become read-only bits and the device ignores any Write Status Register (WRSR) command.

9.7 Write Status Register (WRSR)

The Write Status Register (WRSR) command changes the bits in the Status Register. A Write Enable (WREN) command, which itself sets the Write Enable Latch (WEL) in the Status Register, is required prior to writing the WRSR command. [Table 9.2, S25FL064A Status Register on page 20](#) shows the status register bits and their functions.

The host system must drive CS# low, write the WRSR command, and the appropriate data byte on SI ([Figure 9.7](#)).

The WRSR command cannot change the state of the Write Enable Latch (bit 1). The WREN command must be used for that purpose. Bit 0 is a status bit controlled internally by the Flash device. Bits 6 and 5 are always read as 0 and have no user significance.

The WRSR command also controls the value of the Status Register Write Disable (SRWD) bit. The SRWD bit and W# together place the device in the Hardware Protected Mode (HPM). The device ignores all WRSR commands once it enters the Hardware Protected Mode (HPM). [Table 9.3 on page 22](#) shows that W# must be driven low and the SRWD bit must be 1 for this to occur.

Figure 9.7 Write Status Register (WRSR) Command Sequence

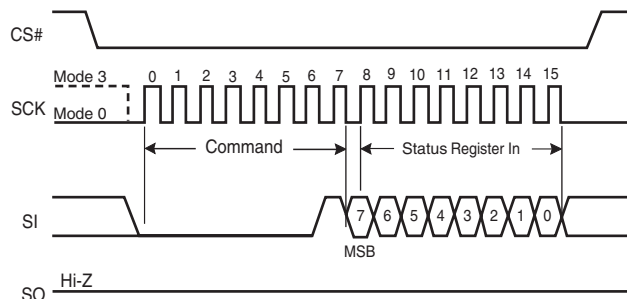

Table 9.3 Protection Modes

W# Signal	SRWD Bit	Mode	Write Protection of the Status Register	Protected Area (See Note)	Unprotected Area (See Note)
1	1	Software Protected (SPM)	Status Register is writable (if the WREN command has set the WEL bit). The values in the SRWD, BP2, BP1 and BP0 bits can be changed.	Protected against program and erase commands	Ready to accept Page Program and Sector Erase commands
1	0				
0	0				
0	1	Hardware Protected (HPM)	Status Register is Hardware write protected. The values in the SRWD, BP2, BP1 and BP0 bits cannot be changed.	Protected against program and erase commands	Ready to accept Page Program and Sector Erase commands

Note

As defined by the values in the Block Protect (BP2, BP1, BP0) bits of the Status Register, as shown in [Table 7.1 on page 13](#).

[Table 9.3](#) shows that neither W# or SRWD bit by themselves can enable HPM. The device can enter HPM either by setting the SRWD bit after driving W# low, or by driving W# low after setting the SRWD bit. However, the device disables HPM only when W# is driven high.

Note that HPM only protects against changes to the status register. Since BP2:BP0 cannot be changed in HPM, the size of the protected area of the memory array cannot be changed. Note that HPM provides no protection to the memory array area outside that specified by BP2:BP0 (Software Protected Mode, or SPM).

If W# is permanently tied high, HPM can never be activated, and only the SPM (BP2:BP0 bits of the Status Register) can be used.

9.8 Page Program (PP)

The Page Program (PP) command changes specified bytes in the memory array (from 1 to 0 only). A WREN command is required prior to writing the PP command.

The host system must drive CS# low, and then write the PP command, three address bytes, and at least one data byte on SI. CS# must be driven low for the entire duration of the PP sequence. The command sequence is shown in [Figure 9.8](#) and [Table 9.4](#) on page 28.

The device programs only the last 256 data bytes sent to the device. If the number of data bytes exceeds this limit, the bytes sent before the last 256 bytes are discarded, and the device begins programming the last 256 bytes sent at the starting address of the specified page. This may result in data being programmed into different addresses within the same page than expected. If fewer than 256 data bytes are sent to device, they are correctly programmed at the requested addresses.

The host system must drive CS# high after the device has latched the 8th bit of the data byte, otherwise the device does not execute the PP command. The PP operation begins as soon as CS# is driven high. The device internally controls the timing of the operation, which requires a period of t_{PP} . The Status Register may be read to check the value of the Write In Progress (WIP) bit while the PP operation is in progress. The WIP bit is 1 during the PP operation, and is 0 when the operation is completed. The device internally resets the Write Enable Latch to 0 before the operation completes (the exact timing is not specified).

The device does not execute a Page Program (PP) command that specifies a page that is protected by the Block Protect bits (BP2:BP0) (see [Table 7.1](#) on page 13).

Figure 9.8 Page Program (PP) Command Sequence

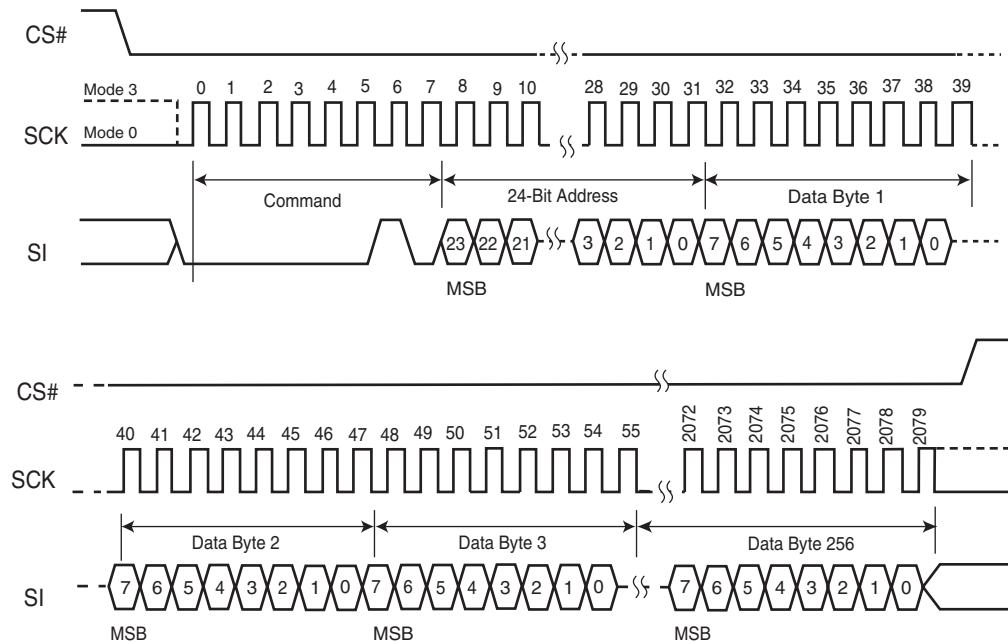

9.9 Sector Erase (SE)

The Sector Erase (SE) command sets all bits at all addresses within a specified sector to a logic 1. A WREN command is required prior to writing the PP command.

The host system must drive CS# low, and then write the SE command plus three address bytes on SI. Any address within the sector (see [Table 7.1 on page 13](#)) is a valid address for the SE command. CS# must be driven low for the entire duration of the SE sequence. The command sequence is shown in [Figure 9.9](#) and [Table 9.4 on page 28](#).

The host system must drive CS# high after the device has latched the 8th bit of the SE command, otherwise the device does not execute the command. The SE operation begins as soon as CS# is driven high. The device internally controls the timing of the operation, which requires a period of t_{SE} . The Status Register may be read to check the value of the Write In Progress (WIP) bit while the SE operation is in progress. The WIP bit is 1 during the SE operation, and is 0 when the operation is completed. The device internally resets the Write Enable Latch to 0 before the operation completes (the exact timing is not specified).

The device does not execute an SE command that specifies a sector that is protected by the Block Protect bits (BP2:BP0) (see [Table 7.1 on page 13](#)).

Figure 9.9 Sector Erase (SE) Command Sequence

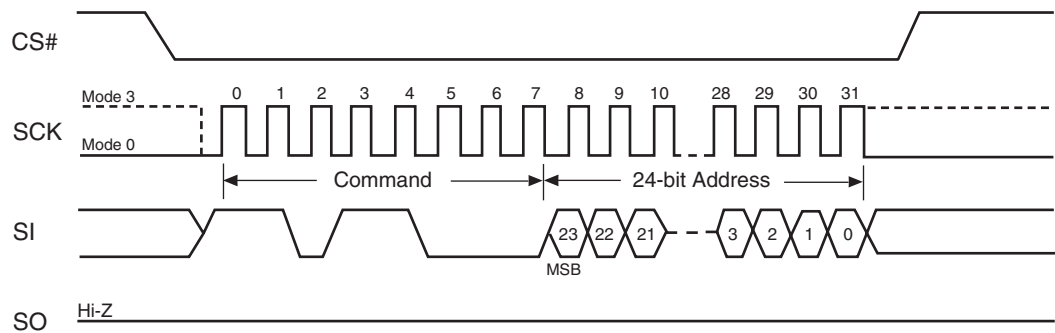

9.10 Bulk Erase (BE)

The Bulk Erase (BE) command sets all the bits within the entire memory array to logic 1s. A WREN command is required prior to writing the PP command.

The host system must drive CS# low, and then write the BE command on SI. CS# must be driven low for the entire duration of the BE sequence. The command sequence is shown in [Figure 9.10](#) and [Table 9.4](#) on page 28.

The host system must drive CS# high after the device has latched the 8th bit of the CE command, otherwise the device does not execute the command. The BE operation begins as soon as CS# is driven high. The device internally controls the timing of the operation, which requires a period of t_{BE} . The Status Register may be read to check the value of the Write In Progress (WIP) bit while the BE operation is in progress. The WIP bit is 1 during the BE operation, and is 0 when the operation is completed. The device internally resets the Write Enable Latch to 0 before the operation completes (the exact timing is not specified).

The device only executes a BE command if all Block Protect bits (BP2:BP0) are 0 (see [Table 7.1](#) on page 13). Otherwise, the device ignores the command.

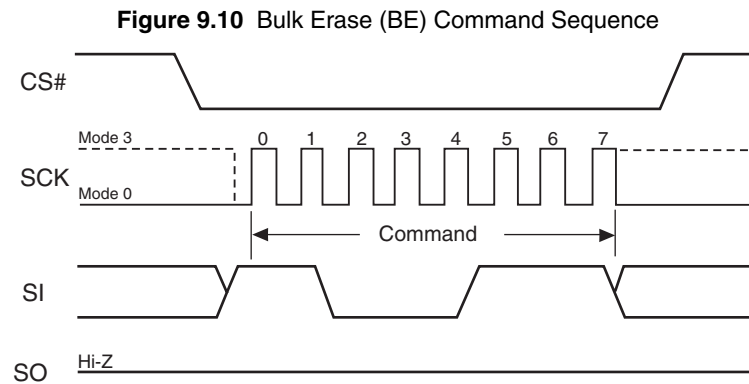

9.11 Deep Power Down (DP)

The Deep Power Down (DP) command provides the lowest power consumption mode of the device. It is intended for periods when the device is not in active use, and ignores all commands except for the Release from Deep Power Down (RES) command. *The DP mode therefore provides the maximum data protection against unintended write operations.* The standard standby mode, which the device goes into automatically when CS# is high (and all operations in progress are complete), should generally be used for the lowest power consumption when the quickest return to device activity is required.

The host system must drive CS# low, and then write the DP command on SI. CS# must be driven low for the entire duration of the DP sequence. The command sequence is shown in [Figure 9.11](#) and [Table 9.4](#) on page 28.

The host system must drive CS# high after the device has latched the 8th bit of the DP command, otherwise the device does not execute the command. After a delay of t_{DP} , the device enters the DP mode and current reduces from I_{SB} to I_{DP} (see [Table 14.1](#) on page 31).

Once the device has entered the DP mode, all commands are ignored except the RES command (which releases the device from the DP mode). The RES command also provides the Electronic Signature of the device to be output on SO, if desired (see [Section 9.12](#) and [9.12.1](#)).

DP mode automatically terminates when power is removed, and the device always powers up in the standard standby mode. The device rejects any DP command issued while it is executing a program, erase, or Write Status Register operation, and continues the operation uninterrupted.

Figure 9.11 Deep Power Down (DP) Command Sequence

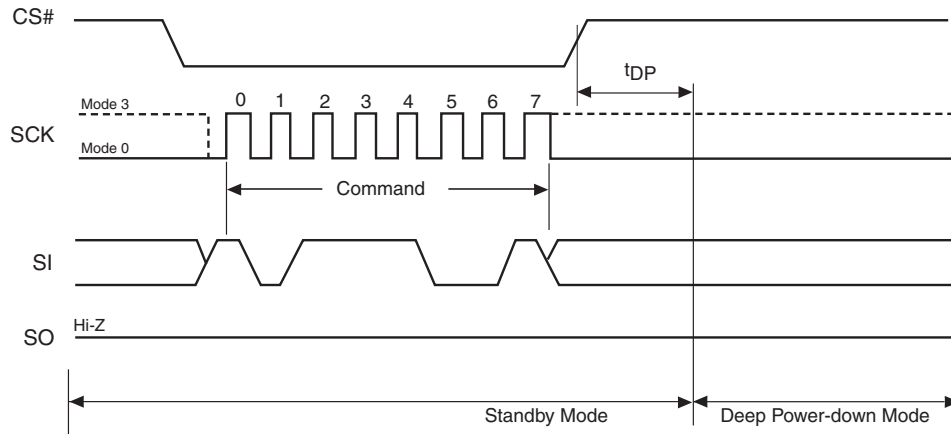

9.12 Release from Deep Power Down (RES)

The device requires the Release from Deep Power Down (RES) command to exit the Deep Power Down mode. When the device is in the Deep Power Down mode, all commands except RES are ignored.

The host system must drive CS# low and write the RES command to SI. CS# must be driven low for the entire duration of the sequence. The command sequence is shown in [Figure 9.12](#) and [Table 9.4 on page 28](#).

The host system must drive CS# high $t_{RES(max)}$ after the 8-bit RES command byte. The device transitions from DP mode to the standby mode after a delay of t_{RES} (see [Table 16.1 on page 32](#)). In the standby mode, the device can execute any read or write command.

Figure 9.12 Release from Deep Power Down (RES) Command Sequence

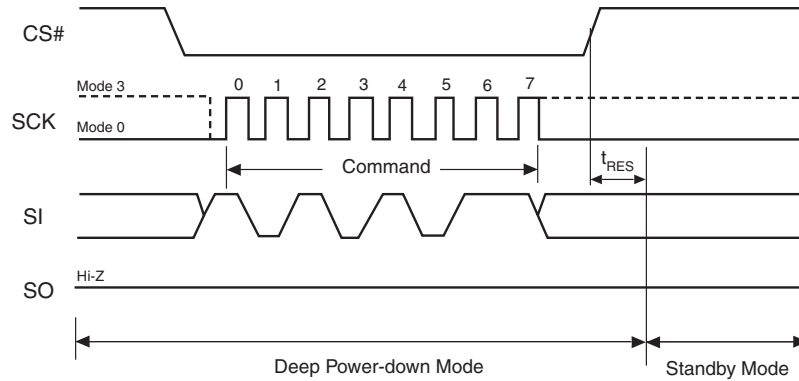

9.12.1 Release from Deep Power Down and Read Electronic Signature (RES)

The device features an 8-bit Electronic Signature, which can be read using the RES command. See [Figure 9.13](#) and [Table 9.4](#) on page 28 for the command sequence and signature value. The Electronic Signature is not to be confused with the identification data obtained using the RDID command. The device offers the Electronic Signature so that it can be used with previous devices that offered it; however, the Electronic Signature should not be used for new designs, which should read the RDID data instead.

After the host system drives CS# low, it must write the RES command followed by 3 dummy bytes to SI (each bit is latched on SI during the rising edge of SCK). The Electronic Signature is then output on SO; each bit is shifted out on the falling edge of SCK. The RES operation is terminated by driving CS# high after the Electronic Signature is read at least once. Additional clock cycles on SCK with CS# low cause the device to output the Electronic Signature repeatedly.

When CS# is driven high, the device transitions from DP mode to the standby mode after a delay of t_{RES} , as previously described. The RES command always provides access to the Electronic Signature of the device and can be applied even if DP mode has not been entered.

Any RES command issued while an erase, program, or WRSR operation is in progress not executed, and the operation continues uninterrupted.

Figure 9.13 Release from Deep Power Down and Read Electronic Signature (RES) Command Sequence

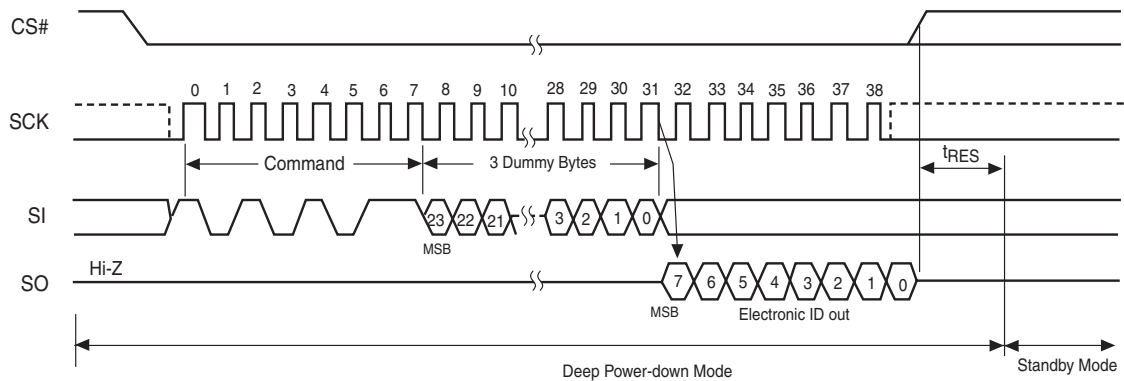

Table 9.4 Command Definitions

Operation	Command	Description	One-Byte Command Code	Address Bytes	Dummy Byte	Data Bytes
Read	READ	Read Data Bytes	03H (0000 0011)	3	0	1 to ∞
	FAST_READ	Read Data Bytes at Higher Speed	0BH (0000 1011)	3	1	1 to ∞
	RDID	Read Identification (Note 1)	9FH (1001 1111)	0	0	1 to 3
Write Control	WREN	Write Enable	06H (0000 0110)	0	0	0
	WRDI	Write Disable	04H (0000 0100)	0	0	0
Erase	SE	Sector Erase	D8H (1101 1000)	3	0	0
	BE	Bulk (Chip) Erase	C7H (1100 0111)	0	0	0
Program	PP	Page Program	02H (0000 0010)	3	0	1 to 256
Status Register	RDSR	Read from Status Register	05H (0000 0101)	0	0	1 to ∞
	WRSR	Write to Status Register	01H (0000 0001)	0	0	1
Power Saving	DP	Deep Power Down	B9H (1011 1001)	0	0	0
	RES	Release from Deep Power Down	ABH (1010 1011)	0	0	0
		Release from Deep Power Down and Read Electronic Signature (Note 2)	ABH (1010 1011)	0	3	1 to ∞

Notes

1. The S25FL064A has a manufacturer ID of 01h, and a device ID consisting of the memory type (02h) and the memory capacity (16h).
2. The S25FL064A has an Electronic Signature ID of 16h.

10. Power-up and Power-down

During power-up and power-down, certain conditions must be observed. CS# must follow the voltage applied on V_{CC} , and must not be driven low to select the device until V_{CC} reaches the allowable values as follows (see [Figure 10.1](#) and [Table 10.1](#)):

- At power-up, V_{CC} (min) plus a period of t_{PU}
- At power-down, V_{SS}

A pull-up resistor on Chip Select (CS#) typically meets proper power-up and power-down requirements.

No Write Status Register, program, or erase command should be sent to the device until V_{CC} rises to the V_{CC} min, plus a delay of t_{PU} . At power-up, the device is in standby mode (not Deep Power Down mode) and the WEL bit is reset (0).

Each device in the host system should have the V_{CC} rail decoupled by a suitable capacitor close to the package pins (this capacitor is generally of the order of 0.1 μF), as a precaution to stabilizing the V_{CC} feed.

When V_{CC} drops from the operating voltage to below the minimum V_{CC} threshold at power-down, all operations are disabled and the device does not respond to any commands. Note that data corruption may result if a power-down occurs while a Write Register, program, or erase operation is in progress.

Figure 10.1 Power-Up Timing Diagram

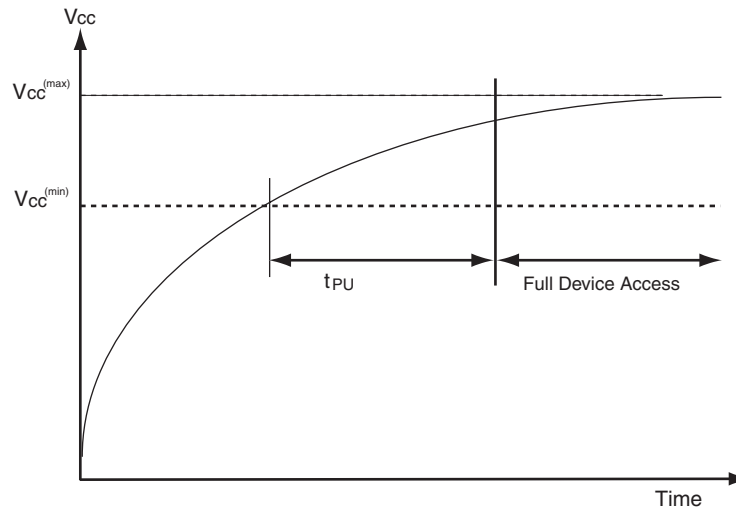

Table 10.1 Power-Up Timing Characteristics

Symbol	Parameter	Min	Max	Unit
$V_{CC(\text{min})}$	V_{CC} (minimum)	2.7		V
t_{PU}	V_{CC} (min) to device operation	10		ms

11. Initial Delivery State

The device is delivered with all bits set to 1 (each byte contains FFh) upon initial factory shipment. The Status Register contains 00h (all Status Register bits are 0).

12. Absolute Maximum Ratings

Do not stress the device beyond the ratings listed in this section, or serious, permanent damage to the device may result. These are stress ratings only and device operation at these or any other conditions beyond those indicated in this section and in the *Operating Ranges* section of this document is not implied. Device operation for extended periods at the limits listed in this section may affect device reliability.

Table 12.1 Absolute Maximum Ratings

Description	Rating
Ambient Storage Temperature	-65°C to +150°C
Voltage with Respect to Ground: All Inputs and I/Os	-0.5 V to $V_{CC}+0.5$ V

Notes

1. Minimum DC voltage on input or I/O pins is -0.5 V. During voltage transitions, input at I/O pins may overshoot V_{SS} to -2.0 V for periods of up to 20 ns. See [Figure 12.2](#). Maximum DC voltage on output and I/O pins is 3.6 V. During voltage transitions output pins may overshoot to $V_{CC} + 2.0$ V for periods up to 20 ns. See [Figure 12.2](#).
2. No more than one output may be shorted to ground at a time. Duration of the short circuit should not be greater than one second.
3. Stresses above those listed under *Absolute Maximum Ratings* may cause permanent damage to the device. This is a stress rating only; functional operation of the device at these or any other conditions above those indicated in the operational sections of this data sheet is not implied. Exposure of the device to absolute maximum rating conditions for extended periods may affect device reliability.

Figure 12.1 Maximum Negative Overshoot Waveform

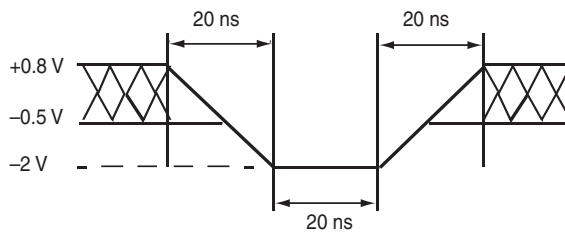
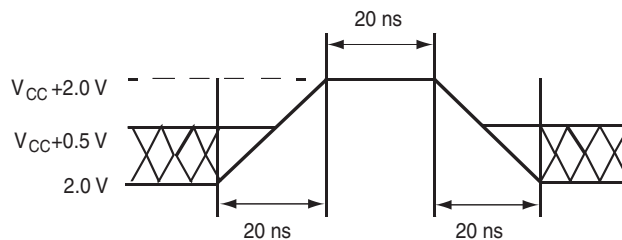

Figure 12.2 Maximum Positive Overshoot Waveform



13. Operating Ranges

Table 13.1 Operating Ranges

Description		Rating
Ambient Operating Temperature (T_A)	Commerical	0°C to +70°C
	Industrial	-40°C to +85°C
Positive Power Supply	Voltage Range	2.7 V to 3.6 V

Note

Operating ranges define those limits between which functionality of the device is guaranteed.

14. DC Characteristics

This section summarizes the DC Characteristics of the device. Designers should check that the operating conditions in their circuit match the measurement conditions specified in the Test Specifications in [Table 15.1 on page 31](#), when relying on the quoted parameters.

Table 14.1 DC Characteristics (CMOS Compatible)

Parameter	Description	Test Conditions (See Note)	Min	Typ.	Max	Unit
V_{CC}	Supply Voltage		2.7	3	3.6	V
I_{CC1}	Active Read Current	SCK = 0.1 $V_{CC}/0.9V_{CC}$ 33 MHz		8	10	mA
		SCK = 0.1 $V_{CC}/0.9V_{CC}$ $V_{CC} = 3.0V$ 50 MHz		10	13	mA
I_{CC2}	Active Page Program Current	CS# = V_{CC}		19.5	28	mA
I_{CC3}	Active WRSR Current	CS# = V_{CC}			28	mA
I_{CC4}	Active Sector Erase Current	CS# = V_{CC}			26	mA
I_{CC5}	Active Bulk Erase Current	CS# = V_{CC}			26	mA
I_{SB}	Standby Current	$V_{CC} = 3.0 V$ CS# = V_{CC}			50	μA
I_{DP}	Deep Power Down Current	$V_{CC} = 3.0 V$ CS# = V_{CC}		1	10	μA
I_{LI}	Input Leakage Current	$V_{IN} = GND$ to V_{CC}			1	μA
I_{LO}	Output Leakage Current	$V_{IN} = GND$ to V_{CC}			1	μA
V_{IL}	Input Low Voltage		-0.3		0.3 V_{CC}	V
V_{IH}	Input High Voltage		0.7 V_{CC}		$V_{CC} + 0.5$	V
V_{OL}	Output Low Voltage	$I_{OL} = 1.6 mA$, $V_{CC} = V_{CC min}$			0.4	V
V_{OH}	Output High Voltage	$I_{OH} = -0.1 mA$	$V_{CC} - 0.2$			V

Note

Typical values are at $T_A = 25^\circ C$ and 3.0 V.

15. Test Conditions

Figure 15.1 AC Measurements I/O Waveform

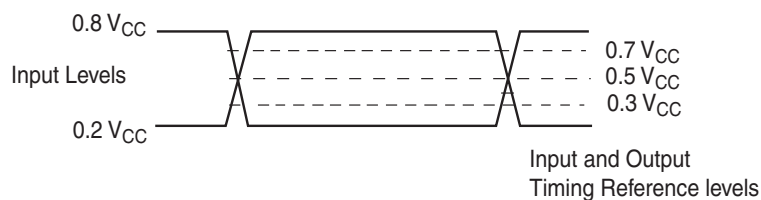

Table 15.1 Test Specifications

Symbol	Parameter	Min	Max	Unit
C_L	Load Capacitance	30		pF
	Input Rise and Fall Times		5	ns
	Input Pulse Voltage	0.2 V_{CC} to 0.8 V_{CC}		V
	Input Timing Reference Voltage	0.3 V_{CC} to 0.7 V_{CC}		V
	Output Timing Reference Voltage	0.5 V_{CC}		V

16. AC Characteristics

Table 16.1 AC Characteristics

Symbol (Notes)	Parameter	Min	Typ (Notes)	Max (Notes)	Unit
F _{SCK}	SCK Clock Frequency READ command	D.C.		25	MHz
F _{SCK}	SCK Clock Frequency for: FAST_READ, PP, SE, BE, DP, RES, WREN, WRDI, RDSR, WRSR	D.C.		50	MHz
t _{CRT}	Clock Rise Time (Slew Rate)	0.1			V/ns
t _{CFT}	Clock Fall Time (Slew Rate)	0.1			V/ns
t _{WH}	SCK High Time	9			ns
t _{WL}	SCK Low Time	9			ns
t _{CS}	CS# High Time	100			ns
t _{CSS} (3)	CS# Setup Time	5			ns
t _{CSH} (3)	CS# HOLD Time	5			ns
t _{HD} (3)	HOLD# Setup Time (relative to SCK)	5			ns
t _{CD} (3)	HOLD# Hold Time (relative to SCK)	5			ns
t _{HC}	HOLD# Setup Time (relative to SCK)	5			ns
t _{CH}	HOLD# Hold Time (relative to SCK)	5			ns
t _V	Output Valid	0		9	ns
t _{HO}	Output Hold Time	0			ns
t _{HD:DAT}	Data in Hold Time	5			ns
t _{SU:DAT}	Data in Setup Time	5			ns
t _R	Input Rise Time			5	ns
t _F	Input Fall Time			5	ns
t _{LZ} (3)	HOLD# to Output Low Z			10	ns
t _{HZ} (3)	HOLD# to Output High Z			10	ns
t _{DIS} (3)	Output Disable Time			10	ns
t _{WPS} (3)	Write Protect Setup Time	15			ns
t _{WPH} (3)	Write Protect Hold Time	15			ns
t _W	Write Status Register Time		67	150	ms
t _{DP}	CS# High to Deep Power Down Mode			3	μs
t _{RES}	Release DP Mode			30	μs
t _{PP}	Page Programming Time		1.5 (1)	3 (2)	ms
t _{SE}	Sector Erase Time		0.5 (1)	3 (2)	sec
t _{BE}	Bulk Erase Time		192 (1)	384 (2)	sec

Notes

1. Typical program and erase times assume the following conditions: 25°C, V_{CC} = 3.0 V; 10,000 cycles; checkerboard data pattern
2. Under worst-case conditions of 90°C; V_{CC} = 2.7V; 100,000 cycles
3. Not 100% tested

Figure 16.1 SPI Mode 0 (0,0) Input Timing

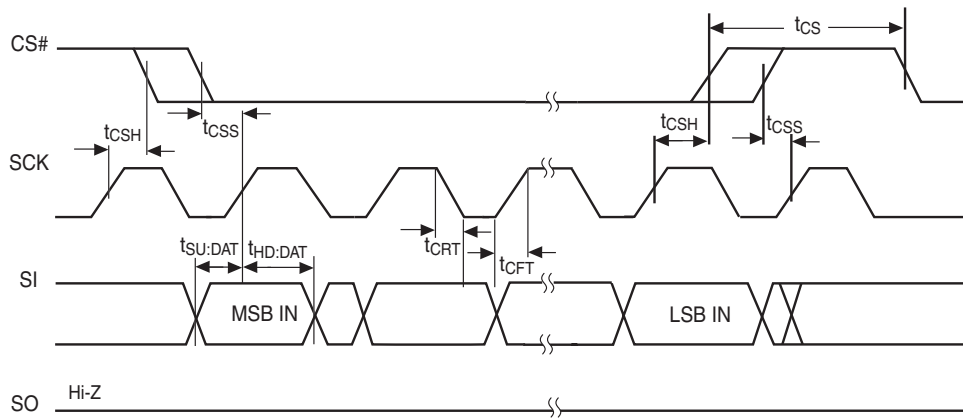

Figure 16.2 SPI Mode 0 (0,0) Output Timing

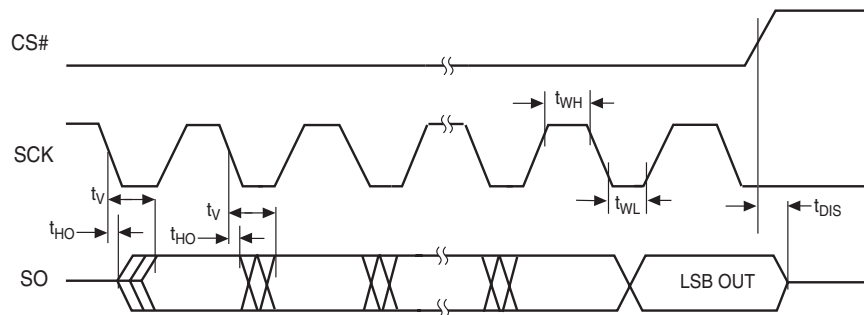

Figure 16.3 HOLD# Timing

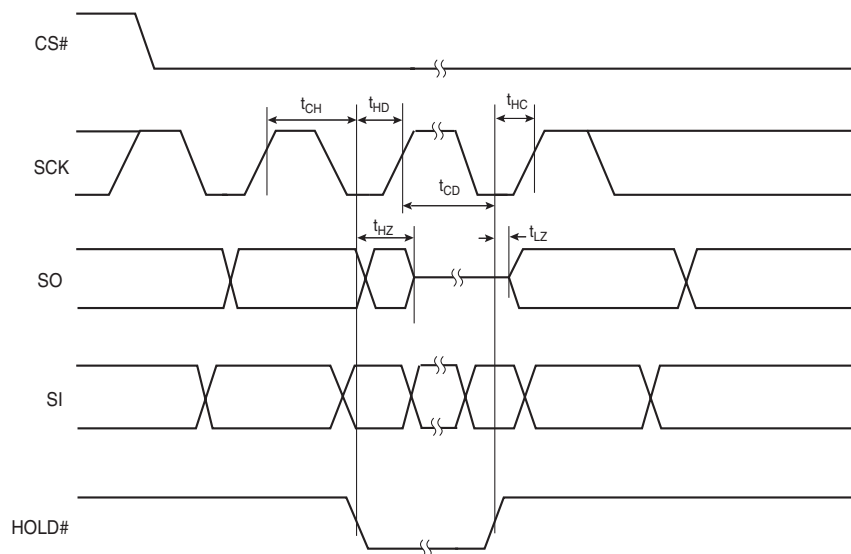
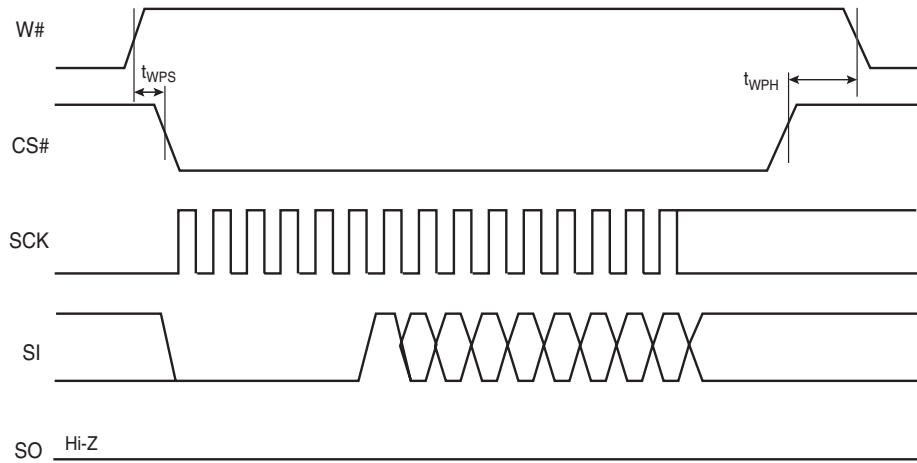
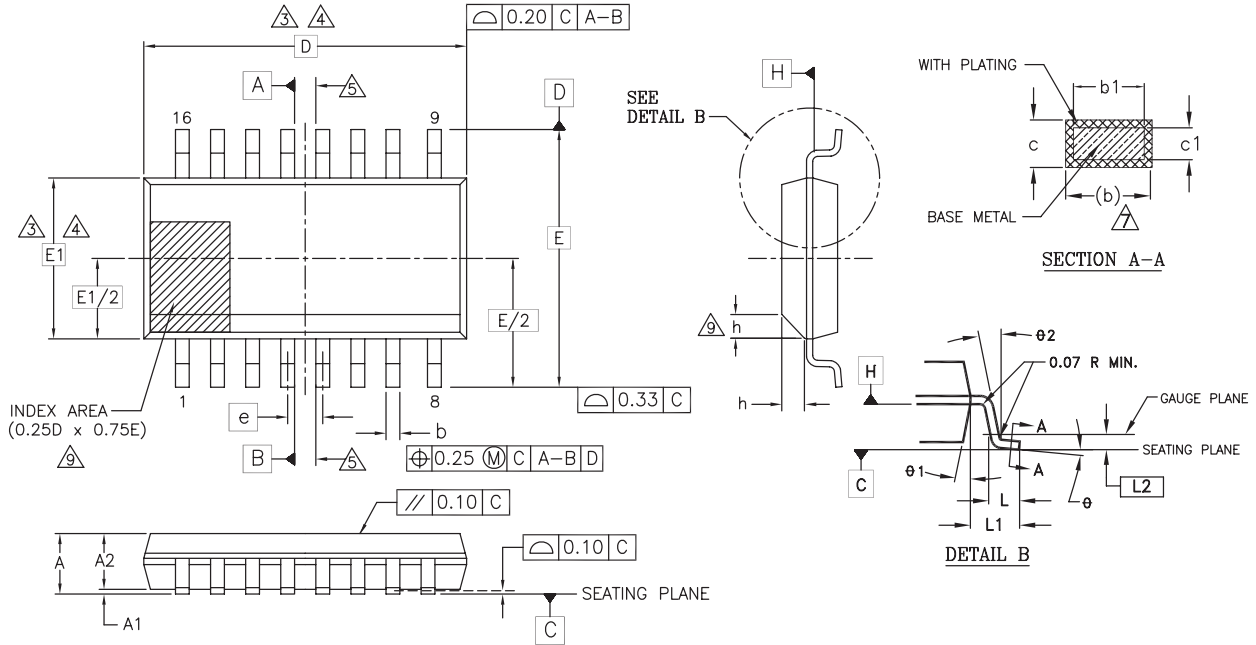

Figure 16.4 Write Protect Setup and Hold Timing during WRSR when SRWD=1



17. Physical Dimensions

17.1 SO3 016 wide—16-pin Plastic Small Outline Package (300-mil Body Width)



PACKAGE	SO3 016 (inches)		SO3 016 (mm)	
	MIN	MAX	MIN	MAX
JEDEC	MS-013(D)AA		MS-013(D)AA	
SYMBOL	MIN	MAX	MIN	MAX
A	0.093	0.104	2.35	2.65
A1	0.004	0.012	0.10	0.30
A2	0.081	0.104	2.05	2.55
b	0.012	0.020	0.31	0.51
b1	0.011	0.019	0.27	0.48
c	0.008	0.013	0.20	0.33
c1	0.008	0.012	0.20	0.30
D	0.406 BSC		10.30 BSC	
E	0.406 BSC		10.30 BSC	
E1	0.295 BSC		7.50 BSC	
e	.050 BSC		1.27 BSC	
L	0.016	0.050	0.40	1.27
L1	.055 REF		1.40 REF	
L2	.010 BSC		0.25 BSC	
N	16		16	
h	0.10	0.30	0.25	0.75
theta	0°	8°	0°	8°
theta1	5°	15°	5°	15°
theta2	0°		0°	

NOTES:

- ALL DIMENSIONS ARE IN BOTH INCHES AND MILLIMETERS.
- DIMENSIONING AND TOLERANCING PER ASME Y14.5M - 1994.
- DIMENSION D DOES NOT INCLUDE MOLD FLASH, PROTRUSIONS OR GATE BURRS. MOLD FLASH, PROTRUSIONS OR GATE BURRS SHALL NOT EXCEED 0.15 mm PER END. DIMENSION E1 DOES NOT INCLUDE INTERLEAD FLASH OR PROTRUSION INTERLEAD FLASH OR PROTRUSION SHALL NOT EXCEED 0.25 mm PER SIDE. D AND E1 DIMENSIONS ARE DETERMINED AT DATUM H.
- THE PACKAGE TOP MAY BE SMALLER THAN THE PACKAGE BOTTOM. DIMENSIONS D AND E1 ARE DETERMINED AT THE OUTMOST EXTREMES OF THE PLASTIC BODY EXCLUSIVE OF MOLD FLASH, TIE BAR BURRS, GATE BURRS AND INTERLEAD FLASH. BUT INCLUDING ANY MISMATCH BETWEEN THE TOP AND BOTTOM OF THE PLASTIC BODY.
- DATUMS A AND B TO BE DETERMINED AT DATUM H.
- "N" IS THE MAXIMUM NUMBER OF TERMINAL POSITIONS FOR THE SPECIFIED PACKAGE LENGTH.
- THE DIMENSIONS APPLY TO THE FLAT SECTION OF THE LEAD BETWEEN 0.10 TO 0.25 mm FROM THE LEAD TIP.
- DIMENSION "b" DOES NOT INCLUDE DAMBAR PROTRUSION. ALLOWABLE DAMBAR PROTRUSION SHALL BE 0.10 mm TOTAL IN EXCESS OF THE "b" DIMENSION AT MAXIMUM MATERIAL CONDITION. THE DAMBAR CANNOT BE LOCATED ON THE LOWER RADIUS OF THE LEAD FOOT.
- THIS CHAMFER FEATURE IS OPTIONAL. IF IT IS NOT PRESENT, THEN A PIN 1 IDENTIFIER MUST BE LOCATED WITHIN THE INDEX AREA INDICATED.
- LEAD COPLANARITY SHALL BE WITHIN 0.10 mm AS MEASURED FROM THE SEATING PLANE.

36011 16-038.03 18.31.6

18. Revision History

Section	Description
Revision A (April 26, 2005)	
Global	Initial release.
Revision B0 (April 18, 2006)	
Global	Changed document status from Advance Information to Preliminary. Changed title from family of devices to specific device.
AC Characteristics table	Updated t_W specifications.
Revision B1 (June 29, 2006)	
DC Characteristics	Changed typical and maximum specifications for I_{CC2} .
Revision C0 (September 6, 2006)	
Global	Rewrote entire document for better flow and clarity. No specifications were changed.
Revision C1 (January 31, 2007)	
AC Characteristics	Changed typical specification for t_{SE} .
Revision C2 (March 14, 2007)	
Global	Changed document status from Preliminary to Full Production.
Absolute Maximum Ratings	Added undershoot and overshoot information.
Revision C3 (June 29, 2007)	
Device Operations	Added a sentence to <i>Byte or Page Programming</i>

Colophon

The products described in this document are designed, developed and manufactured as contemplated for general use, including without limitation, ordinary industrial use, general office use, personal use, and household use, but are not designed, developed and manufactured as contemplated (1) for any use that includes fatal risks or dangers that, unless extremely high safety is secured, could have a serious effect to the public, and could lead directly to death, personal injury, severe physical damage or other loss (i.e., nuclear reaction control in nuclear facility, aircraft flight control, air traffic control, mass transport control, medical life support system, missile launch control in weapon system), or (2) for any use where chance of failure is intolerable (i.e., submersible repeater and artificial satellite). Please note that Spansion will not be liable to you and/or any third party for any claims or damages arising in connection with above-mentioned uses of the products. Any semiconductor devices have an inherent chance of failure. You must protect against injury, damage or loss from such failures by incorporating safety design measures into your facility and equipment such as redundancy, fire protection, and prevention of over-current levels and other abnormal operating conditions. If any products described in this document represent goods or technologies subject to certain restrictions on export under the Foreign Exchange and Foreign Trade Law of Japan, the US Export Administration Regulations or the applicable laws of any other country, the prior authorization by the respective government entity will be required for export of those products.

Trademarks and Notice

The contents of this document are subject to change without notice. This document may contain information on a Spansion product under development by Spansion. Spansion reserves the right to change or discontinue work on any product without notice. The information in this document is provided as is without warranty or guarantee of any kind as to its accuracy, completeness, operability, fitness for particular purpose, merchantability, non-infringement of third-party rights, or any other warranty, express, implied, or statutory. Spansion assumes no liability for any damages of any kind arising out of the use of the information in this document.

Copyright © 2005-2007 Spansion Inc. All rights reserved. Spansion®, the Spansion Logo, MirrorBit®, MirrorBit® Eclipse™, ORNAND™, HD-SIM™ and combinations thereof, are trademarks of Spansion LLC in the US and other countries. Other names used are for informational purposes only and may be trademarks of their respective owners.