



Multi-Purpose Flash™ (MPF™) Multi-Purpose Flash Plus (MPF+)

39 Series

Product Brief
September 2010

Product Description

Multi-Purpose Flash™ (MPF™) and Multi-Purpose Flash Plus (MPF+) make up a family of parallel flash memory products that deliver high performance, low power consumption, superior reliability and small sector size. Based on SST® SuperFlash® technology, MPF and MPF+ provide faster program, erase and read times than conventional flash, thereby saving power consumption and increasing manufacturing throughput.

In addition to offering 3V and 5V memory products, MPF and MPF+ provide 1.8V devices that deliver significant power savings compared to industry standard flash. Ideal for space-constrained applications, this family offers the industry's smallest standard packages, the XFLGA and WFBGA, both as small as 4mm x 6mm.

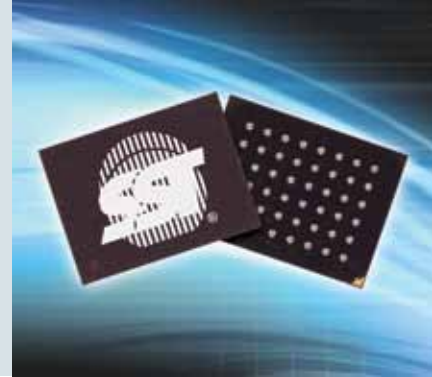

Key Features

Operating Voltages

- 1.65-1.95V
- 2.7-3.6V
- 4.5-5.5V

Low Power Consumption*

- Active current: 5 mA (typical)
- Standby current: 3 µA (typical)

Fast Read Access Times*

- 45 ns
- 55 ns
- 70 ns

Fast Programming*

- 14 µs per word (typical)

Flexible Erase Capability and Fast Erase Times*

- 2 KWord sector erase: 18 ms (typical)
- 32 KWord block erase: 18 ms (typical)
- Chip erase: 70 ms (typical)

Small uniform sector sizes: 2 KWord and 32 KWord Commercial and industrial operating temperatures

Endurance: 100,000 cycles (typical)

Data Retention: 100 years (min)

MPF+ Offers Additional Features

- Erase suspend
- Boot block
- Hardware reset features

* Data varies for different devices.
For details, please refer to datasheet.



39 Series: Multi-Purpose Flash (MPF) Packages*									
Voltage	Density	32-pin PDIP (PHE)	32-pin PLCC (NHE)	32-pin TSOP (WHE)	34-ball WFBGA (MME)	48-ball TFBGA (B3KE)	48-lead TSOP (EKE)	48-bump XFLGA (C1QE) (CAQE)	48-ball WFBGA (M1QE) (MAQE)
1.8V	4 Mbit					•		•	•
	8 Mbit					•		•	•
	16 Mbit					•		•	•
3V	512 Kbit		•	•					
	1 Mbit		•	•	•	•			
	2 Mbit		•	•	•	•	•		•
	4 Mbit		•	•		•	•	•	•
	8 Mbit					•	•	•	•
	16 Mbit					•	•	•	•
	32 Mbit					•	•		
64 Mbit					•	•			
5V	1 Mbit	•	•	•					
	2 Mbit	•	•	•					
	4 Mbit	•	•	•					

* Wafer/Die (Known Good Die) sales of above devices are also available.
Please contact SST sales for detailed information.

Applications

- Bluetooth
- GPS
- Digital TVs
- Digital Media Players, MP3 players
- WiFi/ WiMAX
- Printers
- Digital Photo Frames
- Mobile Phones
- DSL/Cable Modems
- Servers and Routers
- Set Top Boxes
- Digital Cameras
- Industrial
- Automotive Infotainment

Silicon Storage Technology, Inc.
1020 Kifer Road
Sunnyvale, CA 94086-5308
Tel: (408) 735-9110
Fax: (408) 735-9036

www.SST.com

Parallel Flash Memory, 1.8V

Device	Product Density	Voltage	Access Speed (ns)	Packages
SST39WF400B	4 Mbit (256K x16)	1.65-1.95	70	TFBGA-48 (6mm x 8mm), WFBGA-48 (4mm x 6mm), XFLGA-48 (4mm x 6mm)
SST39WF800B	8 Mbit (512K x16)	1.65-1.95	70	TFBGA-48 (6mm x 8mm), WFBGA-48 (4mm x 6mm), XFLGA-48 (4mm x 6mm)
SST39WF1601/1602	16 Mbit (1Mb x16)	1.65-1.95	70	TFBGA-48 (6mm x 8mm), WFBGA-48 (4mm x 6mm)

Parallel Flash Memory, 3V

Device	Product Density	Voltage	Access Speed (ns)	Packages
SST39LF/VF512	512 Mbit (64K x16)	LF: 3.0-3.6V VF: 2.7-3.6V	LF: 45 VF: 70	PLCC-32, TSOP-32 (8mm x 14mm)
SST39LF/VF010	1 Mbit (128K x8)	LF: 3.0-3.6V VF: 2.7-3.6V	LF: 55 VF: 70	PLCC-32, TSOP-32 (8mm x 14mm), TFBGA-48 (6mm x 8mm) WFBGA-34 (4mm x 6mm)
SST39LF/VF020	2 Mbit (256K x8)	LF: 3.0-3.6V VF: 2.7-3.6V	LF: 55 VF: 70	PLCC-32, TSOP-32 (8mm x 14mm), TFBGA-48 (6mm x 8mm) WFBGA-34 (4mm x 6mm)
SST39LF/VF200A	2 Mbit (128K x16)	LF: 3.0-3.6V VF: 2.7-3.6V	LF: 55 VF: 70	TSOP-48 (12mm x 20mm), TFBGA-48 (6mm x 8mm), WFBGA-48 (4mm x 6mm)
SST39LF/VF040	4 Mbit (512K x8)	LF: 3.0-3.6V VF: 2.7-3.6V	LF: 55 VF: 70	PLCC-32, TSOP-32 (8mm x 14mm), TFBGA-48 (6mm x 8mm)
SST39LF/VF400A	4 Mbit (256K x16)	LF: 3.0-3.6V VF: 2.7-3.6V	LF: 55 VF: 70	TSOP-48 (12mm x 20mm), TFBGA-48 (6mm x 8mm), WFBGA-48 (4mm x 6mm) XFLGA-48 (4mm x 6mm)
SST39LF/VF800A	8 Mbit (512K x16)	LF: 3.0-3.6V VF: 2.7-3.6V	LF: 55 VF: 70	TSOP-48 (12mm x 20mm), TFBGA-48 (6mm x 8mm), WFBGA-48 (4mm x 6mm), XFLGA-48 (4mm x 6mm)
SST39VF1601C/1602C	16 Mbit (1Mb x16)	2.7-3.6V	70	TSOP-48 (12mm x 20mm), TFBGA-48 (6mm x 8mm), WFBGA-48 (4mm x 6mm)
SST39VF1681/1682	16 Mbit (2Mb x8)	2.7-3.6V	70	TSOP-48 (12mm x 20mm), TFBGA-48 (6mm x 8mm)
SST39VF3201B/2B	32 Mbit (2Mb x16)	2.7-3.6V	70	TSOP-48 (12mm x 20mm), TFBGA-48 (6mm x 8mm)
SST39VF6401B/2B	64 Mbit (4Mb x16)	2.7-3.6V	70	TSOP-48 (12mm x 20mm), TFBGA-48 (8mm x 10mm)

Parallel Flash Memory, 5V

Device	Product Density	Voltage Speed (ns)	Access	Packages
SST39SF010A	1 Mbit (128K x8)	4.5-5.5V	55, 70	PLCC-32, TSOP-32 (8mm x 14mm), PDIP-32
SST39SF020A	2 Mbit (256K x8)	4.5-5.5V	55, 70	PLCC-32, TSOP-32 (8mm x 14mm), PDIP-32
SST39SF040	4 Mbit (512K x8)	4.5-5.5V	55, 70	PLCC-32, TSOP-32 (8mm x 14mm), PDIP-32

Functional Block Diagram

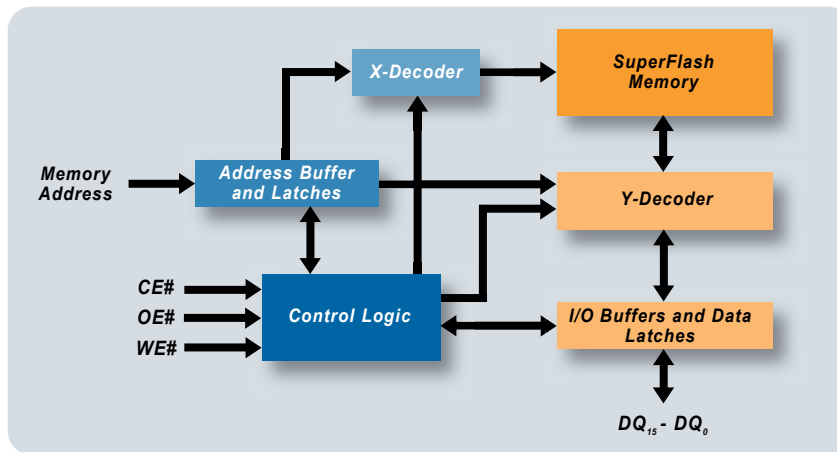

Silicon Storage Technology, Inc.
 1020 Kifer Road, Sunnyvale, CA 94086-5308
 Tel: (408) 735-9110
 Fax: (408) 735-9036
www.SST.com

For more information please contact your local SST Sales Representative.
 See the "Sales" page of www.SST.com for complete listings.

© 2010 Silicon Storage Technology, Inc. The SST logo, SST and SuperFlash are registered trademarks of Silicon Storage Technology, Inc. MPF is a trademark of Silicon Storage Technology, Inc. These specifications are subject to change without notice.

617-01 09/10

Silicon Storage Technology, Inc., a wholly owned subsidiary of Microchip Technology, Inc.