



M95256-DR M95256 M95256-W M95256-R

256 Kbit serial SPI bus EEPROM
with high-speed clock

Features

- Compatible with the Serial Peripheral Interface (SPI) bus
- Memory array
 - 256 Kb (32 Kbytes) of EEPROM
 - Page size: 64 bytes
- Additional Write lockable Page (Identification page)
- Write (self-timed cycle)
 - Byte Write within 5 ms
 - Page Write within 5 ms
- Write Protect: quarter, half or whole memory array
- High-speed clock frequency (20 MHz)
- Single supply voltage: 1.8 V to 5.5 V
- More than 1 million Write cycles
- More than 40-year data retention
- Enhanced ESD Protection
- Packages
 - ECOPACK2® (RoHS compliant and Halogen-free)

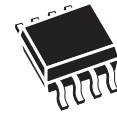

SO8 (MN)
150 mil width

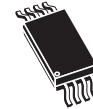

TSSOP8 (DW)
169 mil width



UFDFPN8 (MB, MC)
2 × 3 mm (MLP)



WLCSP (CS)

Contents

| | | |
|----------|---|-----------|
| 1 | Description | 6 |
| 2 | Memory organization | 8 |
| 3 | Signal description | 9 |
| | 3.1 Serial Data output (Q) | 9 |
| | 3.2 Serial Data input (D) | 9 |
| | 3.3 Serial Clock (C) | 9 |
| | 3.4 Chip Select (\overline{S}) | 9 |
| | 3.5 Hold (\overline{HOLD}) | 9 |
| | 3.6 Write Protect (\overline{W}) | 10 |
| | 3.7 V_{SS} ground | 10 |
| | 3.8 Operating supply voltage (V_{CC}) | 10 |
| | 3.8.1 Device reset | 10 |
| | 3.8.2 Power-up conditions | 11 |
| | 3.8.3 Power-down | 11 |
| 4 | Operating features | 11 |
| | 4.1 Hold condition | 11 |
| | 4.2 Status Register | 12 |
| | 4.3 Data protection and protocol control | 12 |
| 5 | Instructions | 14 |
| | 5.1 Write Enable (WREN) | 15 |
| | 5.2 Write Disable (WRDI) | 15 |
| | 5.3 Read Status Register (RDSR) | 16 |
| | 5.3.1 WIP bit | 16 |
| | 5.3.2 WEL bit | 16 |
| | 5.3.3 BP1, BP0 bits | 16 |
| | 5.3.4 SRWD bit | 16 |
| | 5.4 Write Status Register (WRSR) | 17 |
| | 5.5 Read from Memory Array (READ) | 19 |
| | 5.6 Write to Memory Array (WRITE) | 20 |

| | | |
|-----------|--|-----------|
| 5.6.1 | ECC (error correction code) and Write cycling | 22 |
| 5.7 | Read Identification Page (available only in M95256-DR devices) | 22 |
| 5.8 | Write Identification Page | 23 |
| 5.9 | Read Lock Status (available only in M95256-DR devices) | 24 |
| 5.10 | Lock ID (available only in M95256-DR devices) | 24 |
| 6 | Delivery state | 26 |
| 7 | Connecting to the SPI bus | 26 |
| 7.1 | SPI modes | 27 |
| 8 | Maximum rating | 28 |
| 9 | DC and AC parameters | 29 |
| 10 | Package mechanical data | 38 |
| 11 | Part numbering | 42 |
| 12 | Revision history | 43 |

List of tables

| | | |
|-----------|---|----|
| Table 1. | Signal names | 7 |
| Table 2. | Write-protected block size | 13 |
| Table 3. | Instruction set | 14 |
| Table 4. | M95256-D instruction set | 14 |
| Table 5. | Status Register format | 16 |
| Table 6. | Protection modes | 18 |
| Table 7. | Absolute maximum ratings | 28 |
| Table 8. | Operating conditions (M95256) | 29 |
| Table 9. | Operating conditions (M95256-W) | 29 |
| Table 10. | Operating conditions (M95256-R and M95256-DR) | 29 |
| Table 11. | AC measurement conditions | 29 |
| Table 12. | Capacitance | 30 |
| Table 13. | DC characteristics (M95256, device grade 3) | 30 |
| Table 14. | DC characteristics (M95256-W, device grade 6) | 31 |
| Table 15. | DC characteristics (M95256-W, device grade 3) | 32 |
| Table 16. | DC characteristics (M95256-R, M95256-DR, device grade 6) | 32 |
| Table 17. | AC characteristics (M95256, device grade 3) | 33 |
| Table 18. | AC characteristics, M95256-W, device grade 6 | 34 |
| Table 19. | AC characteristics (M95256-W, device grade 3) | 35 |
| Table 20. | AC characteristics (M95256-DR, M95256-R device grade 6) | 36 |
| Table 21. | SO8N – 8 lead plastic small outline, 150 mils body width, package data | 38 |
| Table 22. | TSSOP8 – 8 lead thin shrink small outline, package mechanical data | 39 |
| Table 23. | UFDFPN8 (MLP8) 8-lead ultra thin fine pitch dual flat package no lead 2 x 3 mm, data | 40 |
| Table 24. | M95256-DR WLCSP, 0.5 mm pitch, package mechanical data | 41 |
| Table 25. | Ordering information scheme | 42 |
| Table 26. | Document revision history | 43 |

List of figures

| | | |
|------------|---|----|
| Figure 1. | Logic diagram | 6 |
| Figure 2. | 8-pin package connections | 6 |
| Figure 3. | WLCSP connections (top view, marking side, with balls on the underside) | 7 |
| Figure 4. | Block diagram | 8 |
| Figure 5. | Hold condition activation | 12 |
| Figure 6. | Write Enable (WREN) sequence | 15 |
| Figure 7. | Write Disable (WRDI) sequence | 15 |
| Figure 8. | Read Status Register (RDSR) sequence | 17 |
| Figure 9. | Write Status Register (WRSR) sequence | 19 |
| Figure 10. | Read from Memory Array (READ) sequence | 20 |
| Figure 11. | Byte Write (WRITE) sequence | 21 |
| Figure 12. | Page Write (WRITE) sequence | 21 |
| Figure 13. | Read Identification Page sequence | 23 |
| Figure 14. | Write Identification Page sequence | 23 |
| Figure 15. | Read Lock Status sequence | 24 |
| Figure 16. | Lock ID sequence | 25 |
| Figure 17. | Bus master and memory devices on the SPI bus | 26 |
| Figure 18. | SPI modes supported | 27 |
| Figure 19. | AC measurement I/O waveform | 30 |
| Figure 20. | Serial input timing | 37 |
| Figure 21. | Hold timing | 37 |
| Figure 22. | Output timing | 37 |
| Figure 23. | SO8N – 8 lead plastic small outline, 150 mils body width, package outline | 38 |
| Figure 24. | TSSOP8 – 8 lead thin shrink small outline, package outline | 39 |
| Figure 25. | UFDFPN8 (MLP8) – 8-lead ultra thin fine pitch dual flat package no lead 2 × 3mm, package outline | 40 |
| Figure 26. | M95256-DR WLCSP, 0.5 mm pitch, package outline | 41 |

1 Description

The M95256, M95256-W, M95256-R and M95256-DR are electrically erasable programmable memory (EEPROM) devices. They are accessed by a high speed SPI-compatible bus. Their memory array is organized as 32768×8 bits.

The M95256-DR also offers an additional page, named the Identification Page (64 bytes) which can be written and (later) permanently locked in Read-only mode. This Identification Page offers flexibility in the application board production line, as the Identification Page can be used to store unique identification parameters and/or parameters specific to the production line.

The device is accessed by a simple serial interface that is SPI-compatible.

Figure 1. Logic diagram

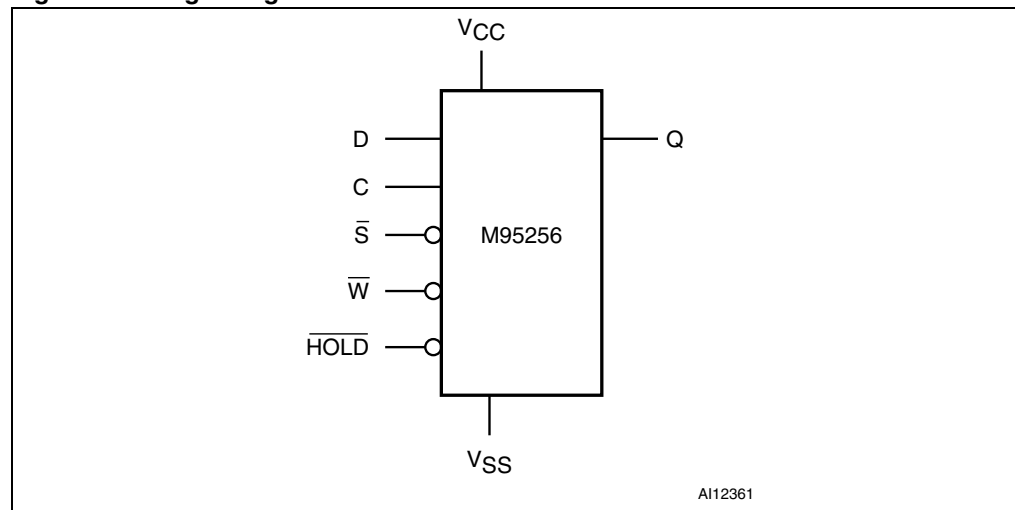

The bus signals are C, D and Q, as shown in [Table 1](#) and [Figure 1](#).

The device is selected when Chip Select (\overline{S}) is taken low. Communications with the device can be interrupted using Hold (\overline{HOLD}).

Figure 2. 8-pin package connections

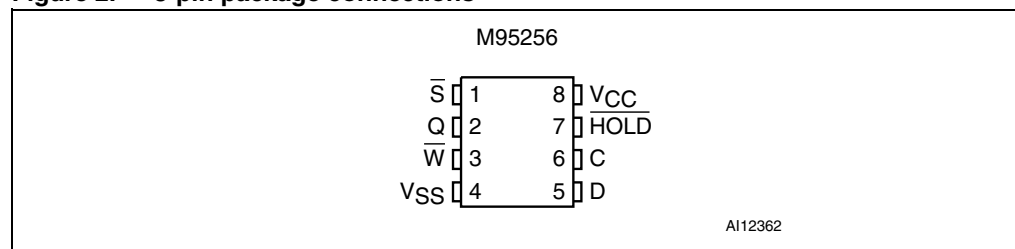

1. See [Section 10: Package mechanical data](#) for package dimensions, and how to identify pin-1.

Caution: As EEPROM cells lose their charge (and so their binary value) when exposed to ultra violet (UV) light, EEPROM dice delivered in wafer form or in WLCSP package by ST Microelectronics must never be exposed to UV light.

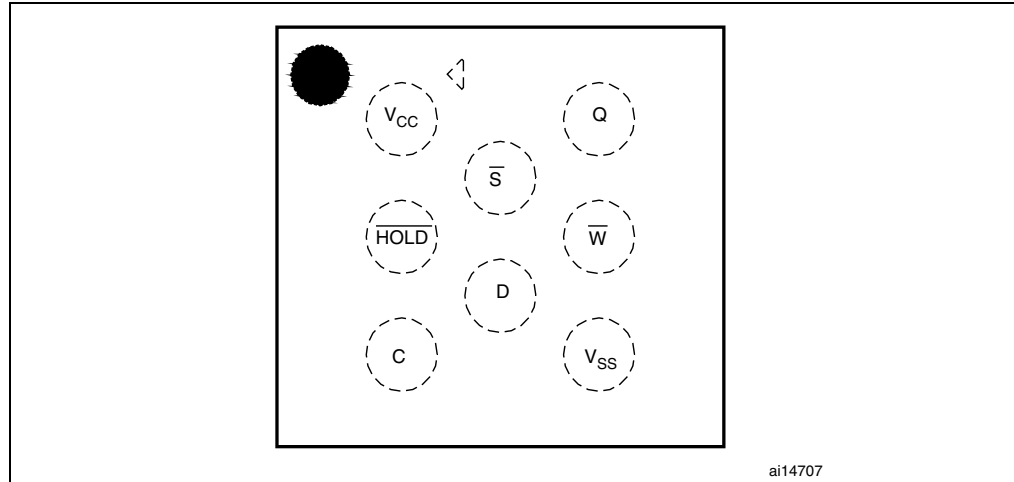
Figure 3. WLCSP connections (top view, marking side, with balls on the underside)

Caution: As EEPROM cells lose their charge (and so their binary value) when exposed to ultra violet (UV) light, EEPROM dice delivered in wafer form or in WLCSP package by STMicroelectronics must never be exposed to UV light.

Table 1. Signal names

| Signal name | Function | Direction |
|-------------------|--------------------|-----------|
| C | Serial Clock | Input |
| D | Serial Data input | Input |
| Q | Serial Data output | Output |
| \overline{S} | Chip Select | Input |
| \overline{W} | Write Protect | Input |
| \overline{HOLD} | Hold | Input |
| V _{CC} | Supply voltage | |
| V _{SS} | Ground | |

2 Memory organization

The memory is organized as shown in [Figure 4](#).

Figure 4. Block diagram

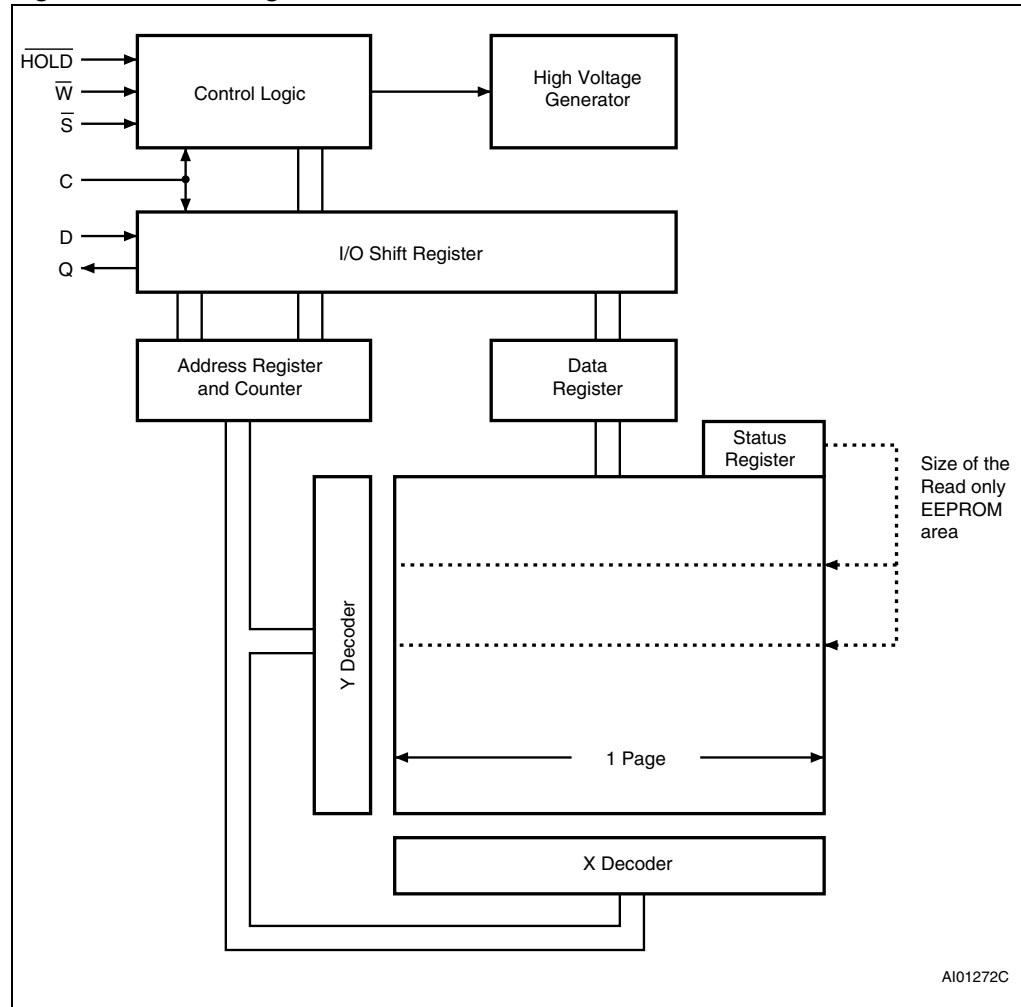

3 Signal description

See [Figure 1: Logic diagram](#) and [Table 1: Signal names](#), for a brief overview of the signals connected to this device.

3.1 Serial Data output (Q)

This output signal is used to transfer data serially out of the device. Data is shifted out on the falling edge of Serial Clock (C).

3.2 Serial Data input (D)

This input signal is used to transfer data serially into the device. It receives instructions, addresses, and the data to be written. Values are latched on the rising edge of Serial Clock (C).

3.3 Serial Clock (C)

This input signal provides the timing of the serial interface. Instructions, addresses, or data present at Serial Data input (D) are latched on the rising edge of Serial Clock (C). Data on Serial Data output (Q) changes after the falling edge of Serial Clock (C).

3.4 Chip Select (\overline{S})

When this input signal is high, the device is deselected and Serial Data output (Q) is at high impedance. Unless an internal Write cycle is in progress, the device will be in the Standby Power mode. Driving Chip Select (\overline{S}) low selects the device, placing it in the Active Power mode.

After power-up, a falling edge on Chip Select (\overline{S}) is required prior to the start of any instruction.

3.5 Hold (\overline{HOLD})

The Hold (\overline{HOLD}) signal is used to pause any serial communications with the device without deselecting the device.

During the Hold condition, the Serial Data output (Q) is high impedance, and Serial Data input (D) and Serial Clock (C) are Don't Care.

To start the Hold condition, the device must be selected, with Chip Select (\overline{S}) driven low.

3.6 Write Protect (\overline{W})

The main purpose of this input signal is to freeze the size of the area of memory that is protected against Write instructions (as specified by the values in the BP1 and BP0 bits of the Status Register).

This pin must be driven either high or low, and must be stable during all write instructions.

3.7 V_{SS} ground

V_{SS} is the reference for the V_{CC} supply voltage.

3.8 Operating supply voltage (V_{CC})

Prior to selecting the memory and issuing instructions to it, a valid and stable V_{CC} voltage within the specified [$V_{CC(\min)}$, $V_{CC(\max)}$] range must be applied (see [Table 8](#), [Table 9](#), [Table 10](#)).

This voltage must remain stable and valid until the end of the transmission of the instruction and, for a Write instruction, until the completion of the internal write cycle (t_W).

In order to secure a stable DC supply voltage, it is recommended to decouple the V_{CC} line with a suitable capacitor (usually of the order of 10 nF to 100 nF) close to the V_{CC}/V_{SS} package pins.

3.8.1 Device reset

In order to prevent inadvertent write operations during power-up, a power-on-reset (POR) circuit is included. At power-up, the device does not respond to any instruction until V_{CC} reaches the internal Reset threshold voltage (this threshold is defined in DC tables as V_{RES}). (this threshold is lower than the minimum V_{CC} operating voltage defined in [Table 8](#), [Table 9](#) and [Table 10](#)).

When V_{CC} passes over the POR threshold, the device is reset and in the following state:

- in Standby Power mode,
- deselected (note that a further instruction must be preceded by a falling edge on Chip Select (\overline{S}) to be executed),
- Status Register value:
 - the Write Enable Latch (WEL) is reset to 0,
 - Write In Progress (WIP) is reset to 0,
 - The SRWD, BP1 and BP0 bits remain unchanged (non-volatile bits)

When V_{CC} passes over the POR threshold, the device is reset and enters the Standby Power mode, however, the device must not be accessed until V_{CC} reaches a valid and stable V_{CC} voltage within the specified [$V_{CC(\min)}$, $V_{CC(\max)}$] range defined in [Table 8](#), [Table 9](#) and [Table 10](#).

3.8.2 Power-up conditions

When the power supply is turned on, V_{CC} rises continuously from V_{SS} to V_{CC} . During this time, the Chip Select (\overline{S}) line is not allowed to float but should follow the V_{CC} voltage, it is therefore recommended to connect the \overline{S} line to V_{CC} via a suitable pull-up resistor (see [Figure 17](#)).

In addition, the Chip Select (\overline{S}) input offers a built-in safety feature, as the \overline{S} input is edge sensitive as well as level sensitive: after power-up, the device does not become selected until a falling edge has first been detected on Chip Select (\overline{S}). This ensures that Chip Select (\overline{S}) must have been High, prior to going Low to start the first operation.

The V_{CC} voltage has to rise continuously from 0 V up to the minimum V_{CC} operating voltage defined in [Table 8](#), [Table 9](#) and [Table 10](#) and the rise time must not vary faster than 1 V/ μ s.

3.8.3 Power-down

During Power-down (continuous decrease of V_{CC} supply voltage below the minimum V_{CC} operating voltage defined in [Table 8](#), [Table 9](#) and [Table 10](#)), the device must be:

- deselected (Chip Select \overline{S} should be allowed to follow the voltage applied on V_{CC})
- in Standby Power mode (there should not be an internal Write cycle in progress).

4 Operating features

4.1 Hold condition

The Hold (\overline{HOLD}) signal is used to pause any serial communications with the device without resetting the clocking sequence.

During the Hold condition, the Serial Data output (Q) is high impedance, and Serial Data input (D) and Serial Clock (C) are Don't Care.

To enter the Hold condition, the device must be selected, with Chip Select (\overline{S}) low.

Normally, the device is kept selected, for the whole duration of the Hold condition. Deselecting the device while it is in the Hold condition, has the effect of resetting the state of the device, and this mechanism can be used if it is required to reset any processes that had been in progress.

The Hold condition starts when the Hold (\overline{HOLD}) signal is driven low at the same time as Serial Clock (C) already being low (as shown in [Figure 5](#)).

The Hold condition ends when the Hold (\overline{HOLD}) signal is driven high at the same time as Serial Clock (C) already being low.

[Figure 5](#) also shows what happens if the rising and falling edges are not timed to coincide with Serial Clock (C) being low.

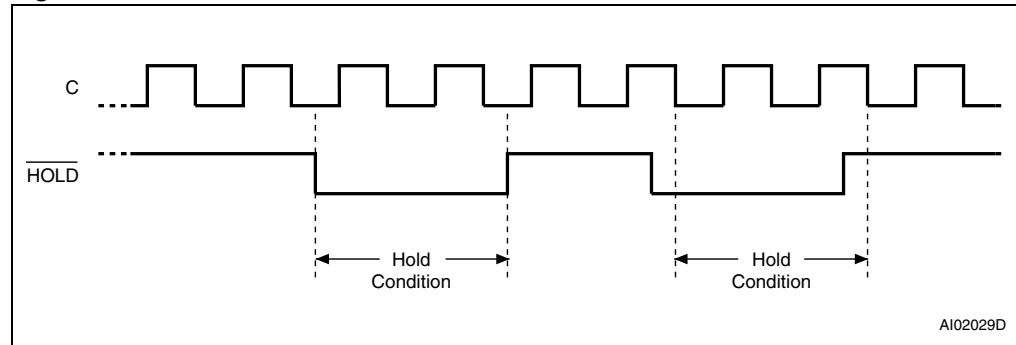
Figure 5. Hold condition activation

4.2 Status Register

Figure 4 shows the position of the Status Register in the control logic of the device. The Status Register contains a number of status and control bits that can be read or set (as appropriate) by specific instructions. For a detailed description of the Status Register bits, see [Section 5.3: Read Status Register \(RDSR\)](#).

4.3 Data protection and protocol control

Non-volatile memory devices can be used in environments that are particularly noisy, and within applications that could experience problems if memory bytes are corrupted. Consequently, the device features the following data protection mechanisms:

- Write and Write Status Register instructions are checked that they consist of a number of clock pulses that is a multiple of eight, before they are accepted for execution.
- All instructions that modify data must be preceded by a Write Enable (WREN) instruction to set the Write Enable Latch (WEL) bit. This bit is returned to its reset state by the following events:
 - Power-up
 - Write Disable (WRDI) instruction completion
 - Write Status Register (WRSR) instruction completion
 - Write (WRITE) instruction completion
- The Block Protect (BP1, BP0) bits in the Status Register allow part of the memory to be configured as read-only.
- The Write Protect (\overline{WP}) signal is used to protect the Block Protect (BP1, BP0) bits of the Status Register.

For any instruction to be accepted, and executed, Chip Select (\overline{CS}) must be driven high after the rising edge of Serial Clock (C) for the last bit of the instruction, and before the next rising edge of Serial Clock (C).

Two points need to be noted in the previous sentence:

- The 'last bit of the instruction' can be the eighth bit of the instruction code, or the eighth bit of a data byte, depending on the instruction (except for Read Status Register (RDSR) and Read (READ) instructions).
- The 'next rising edge of Serial Clock (C)' might (or might not) be the next bus transaction for some other device on the SPI bus.

Table 2. Write-protected block size

| Status Register bits | | Protected block | Protected array address |
|----------------------|-----|-----------------|----------------------------|
| BP1 | BP0 | | M95256, M95256-W, M95256-R |
| 0 | 0 | none | none |
| 0 | 1 | Upper quarter | 6000h - 7FFFh |
| 1 | 0 | Upper half | 4000h - 7FFFh |
| 1 | 1 | Whole memory | 0000h - 7FFFh |

5 Instructions

Each instruction starts with a single-byte code, as summarized in [Table 3](#).

If an invalid instruction is sent (one not contained in [Table 3](#)), the device automatically deselects itself.

Table 3. Instruction set

| Instruction | Description | Instruction format |
|-------------|------------------------|--------------------|
| WREN | Write Enable | 0000 0110 |
| WRDI | Write Disable | 0000 0100 |
| RDSR | Read Status Register | 0000 0101 |
| WRSR | Write Status Register | 0000 0001 |
| READ | Read from Memory Array | 0000 0011 |
| WRITE | Write to Memory Array | 0000 0010 |

Table 4. M95256-D instruction set

| Instruction | Description | Instruction format |
|---------------------------|---|--------------------------|
| WREN | Write Enable | 0000 0110 |
| WRDI | Write Disable | 0000 0100 |
| RDSR | Read Status Register | 0000 0101 |
| WRSR | Write Status Register | 0000 0001 |
| READ | Read from Memory Array | 0000 0011 |
| WRITE | Write to Memory Array | 0000 0010 |
| Read Identification Page | Reads the page dedicated to identification. | 1000 0011 ⁽¹⁾ |
| Write Identification Page | Writes the page dedicated to identification. | 1000 0010 ⁽¹⁾ |
| Read Lock Status | Reads the lock status of the Identification Page. | 1000 0011 ⁽²⁾ |
| Lock ID | Locks the Identification page in read-only mode. | 1000 0010 ⁽²⁾ |

1. Address bit A10 must be 0, all other address bits are Don't Care.
2. Address bit A10 must be 1, all other address bits are Don't Care.

5.1 Write Enable (WREN)

The Write Enable Latch (WEL) bit must be set prior to each WRITE and WRSR instruction. The only way to do this is to send a Write Enable instruction to the device.

As shown in [Figure 6](#), to send this instruction to the device, Chip Select (\overline{S}) is driven low, and the bits of the instruction byte are shifted in, on Serial Data input (D). The device then enters a wait state. It waits for a the device to be deselected, by Chip Select (\overline{S}) being driven high.

Figure 6. Write Enable (WREN) sequence

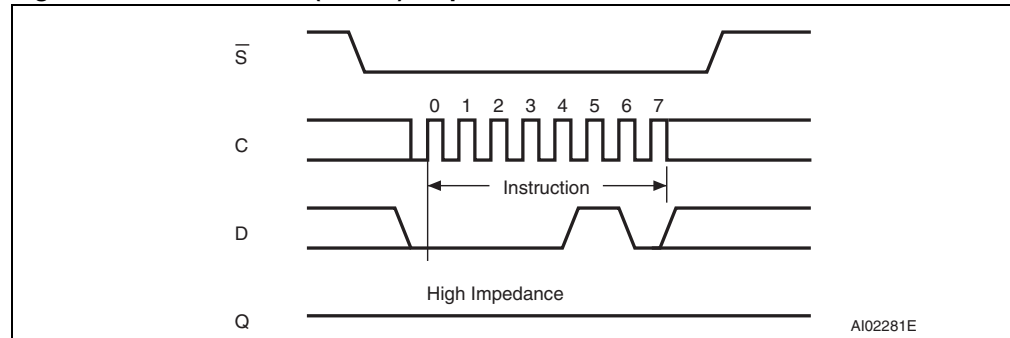

5.2 Write Disable (WRDI)

One way of resetting the Write Enable Latch (WEL) bit is to send a Write Disable instruction to the device.

As shown in [Figure 7](#), to send this instruction to the device, Chip Select (\overline{S}) is driven low, and the bits of the instruction byte are shifted in, on Serial Data input (D).

The device then enters a wait state. It waits for a the device to be deselected, by Chip Select (\overline{S}) being driven high.

The Write Enable Latch (WEL) bit, in fact, becomes reset by any of the following events:

- Power-up
- WRDI instruction execution
- WRSR instruction completion
- WRITE instruction completion

Figure 7. Write Disable (WRDI) sequence

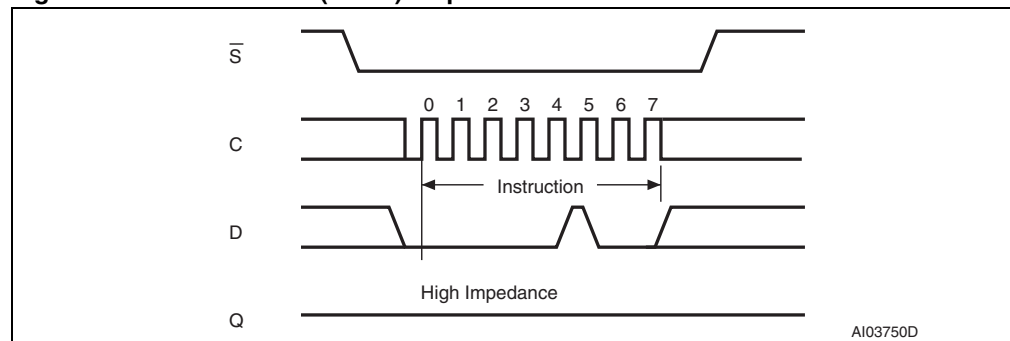

5.3 Read Status Register (RDSR)

The Read Status Register (RDSR) instruction allows the Status Register to be read. The Status Register may be read at any time, even while a Write or Write Status Register cycle is in progress. When one of these cycles is in progress, it is recommended to check the Write In Progress (WIP) bit before sending a new instruction to the device. It is also possible to read the Status Register continuously, as shown in [Figure 8](#).

The status and control bits of the Status Register are as follows:

5.3.1 WIP bit

The Write In Progress (WIP) bit indicates whether the memory is busy with a Write or Write Status Register cycle. When set to 1, such a cycle is in progress, when reset to 0 no such cycle is in progress.

5.3.2 WEL bit

The Write Enable Latch (WEL) bit indicates the status of the internal Write Enable Latch. When set to 1 the internal Write Enable Latch is set, when set to 0 the internal Write Enable Latch is reset and no Write or Write Status Register instruction is accepted.

5.3.3 BP1, BP0 bits

The Block Protect (BP1, BP0) bits are non-volatile. They define the size of the area to be software protected against Write instructions. These bits are written with the Write Status Register (WRSR) instruction. When one or both of the Block Protect (BP1, BP0) bits is set to 1, the relevant memory area (as defined in [Table 5](#)) becomes protected against Write (WRITE) instructions. The Block Protect (BP1, BP0) bits can be written provided that the Hardware Protected mode has not been set.

5.3.4 SRWD bit

The Status Register Write Disable (SRWD) bit is operated in conjunction with the Write Protect (\overline{W}) signal. The Status Register Write Disable (SRWD) bit and Write Protect (\overline{W}) signal allow the device to be put in the Hardware Protected mode (when the Status Register Write Disable (SRWD) bit is set to 1, and Write Protect (\overline{W}) is driven low). In this mode, the non-volatile bits of the Status Register (SRWD, BP1, BP0) become read-only bits and the Write Status Register (WRSR) instruction is no longer accepted for execution.

Table 5. Status Register format

| b7 | | | | b0 | | | |
|-------------------------------|---|---|---|--------------------|-----|------------------------|-----------------------|
| SRWD | 0 | 0 | 0 | BP1 | BP0 | WEL | WIP |
| Status Register Write Protect | | | | Block Protect Bits | | Write Enable Latch Bit | Write In Progress Bit |

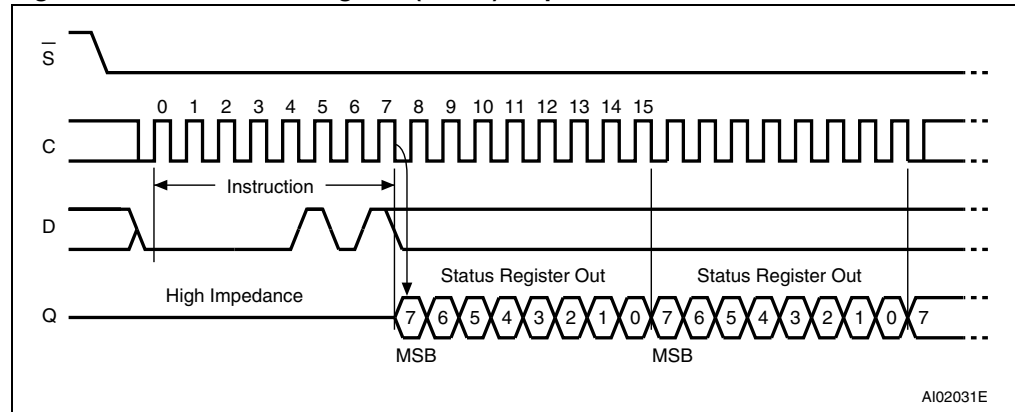
Figure 8. Read Status Register (RDSR) sequence

5.4 Write Status Register (WRSR)

The Write Status Register (WRSR) instruction allows new values to be written to the Status Register. Before it can be accepted, a Write Enable (WREN) instruction must have been previously executed.

The Write Status Register (WRSR) instruction is entered by driving Chip Select (\bar{S}) Low, followed by the instruction code, the data byte on Serial Data Input (D) and the Chip Select (\bar{S}) driven High. Chip Select (\bar{S}) must be driven High after the rising edge of Serial Clock (C) that latches in the eighth bit of the data byte, and before the next rising edge of Serial Clock (C). Otherwise, the Write Status Register (WRSR) instruction is not properly executed.

The instruction sequence is shown in [Figure 9](#).

Driving the Select (\bar{S}) High at a byte boundary of the input data triggers the self timed Write cycle, and continues for a period t_W (as specified in [Table 17](#), [Table 18](#), [Table 19](#) and [Table 20](#)). While the Write Status Register cycle is in progress, the Status Register may still be read to check the value of the Write In Progress (WIP) bit: the WIP bit is 1 during the self-timed Write cycle t_W , and is 0 when the Write cycle is completed. The WEL bit (Write Enable Latch) is also reset when the Write cycle t_W is completed.

The Write Status Register (WRSR) instruction allows the user to change the values of the BP1, BP0 bits and the SRWD bit:

- The Block Protect (BP1, BP0) bits define the size of the area that is to be treated as read only, as defined in [Table 2](#).
- The SRWD bit (Status Register Write Disable bit), in accordance with the signal read on the Write Protect pin (\bar{W}), allows the user to set or reset the Write protection mode of the Status Register itself, as defined in [Table 6](#) When in Write Protected mode, the Write Status Register (WRSR) instruction is not executed.

The contents of the SRWD and BP1, BP0 bits are updated after the completion of the WRSR instruction, including the t_W Write cycle.

The Write Status Register (WRSR) instruction has no effect on bits b6, b5, b4, b1, b0 of the Status Register. Bits b6, b5, b4 are always read as 0.

Table 6. Protection modes

| \bar{W} signal | SRWD bit | Mode | Write protection of the Status Register | Memory content | |
|------------------|----------|--------------------------|---|-------------------------------|------------------------------------|
| | | | | Protected area ⁽¹⁾ | Unprotected area ⁽¹⁾ |
| 1 | 0 | Software Protected (SPM) | Status Register is Writable (if the WREN instruction has set the WEL bit) | Write-protected | Ready to accept Write instructions |
| 0 | 0 | | The values in the BP1 and BP0 bits can be changed | | |
| 1 | 1 | Hardware Protected (HPM) | Status Register is Hardware write protected | Write-protected | Ready to accept Write instructions |
| 0 | 1 | | The values in the BP1 and BP0 bits cannot be changed | | |

1. As defined by the values in the Block Protect (BP1, BP0) bits of the Status Register, as shown in [Table 6](#).

The protection features of the device are summarized in [Table 6](#).

When the Status Register Write Disable (SRWD) bit of the Status Register is 0 (its initial delivery state), it is possible to write to the Status Register (provided that the WEL bit has previously been set by a WREN instruction), regardless of the logic level applied on the Write Protect (\bar{W}) input pin.

When the Status Register Write Disable (SRWD) bit of the Status Register is set to 1, two cases need to be considered, depending on the state of Write Protect (\bar{W}) input pin:

- If Write Protect (\bar{W}) input pin is driven high, it is possible to write to the Status Register (provided that the WEL bit has previously been set by a WREN instruction).
- If Write Protect (\bar{W}) input pin is driven low, it is not possible to write to the Status Register even if the WEL bit has previously been set by a WREN instruction. (Attempts to write to the Status Register are rejected, and are not accepted for execution). As a consequence, all the data bytes in the memory area that are software protected (SPM) by the Block Protect (BP1, BP0) bits of the Status Register, are also hardware protected against data modification.

Regardless of the order of the two events, the Hardware Protected Mode (HPM) can be entered:

- either by setting the SRWD bit after driving Write Protect (\bar{W}) input pin low,
- or by driving Write Protect (\bar{W}) input pin low after setting the SRWD bit.

Once entered in the Hardware Protected mode (HPM), the only way to exit the HPM mode is to pull high the Write Protect (\bar{W}) input pin.

If Write Protect (\bar{W}) input pin is permanently tied high, the Hardware Protected mode (HPM) can never be activated, and only the Software Protected mode (SPM), using the Block Protect (BP1, BP0) bits of the Status Register, can be used.

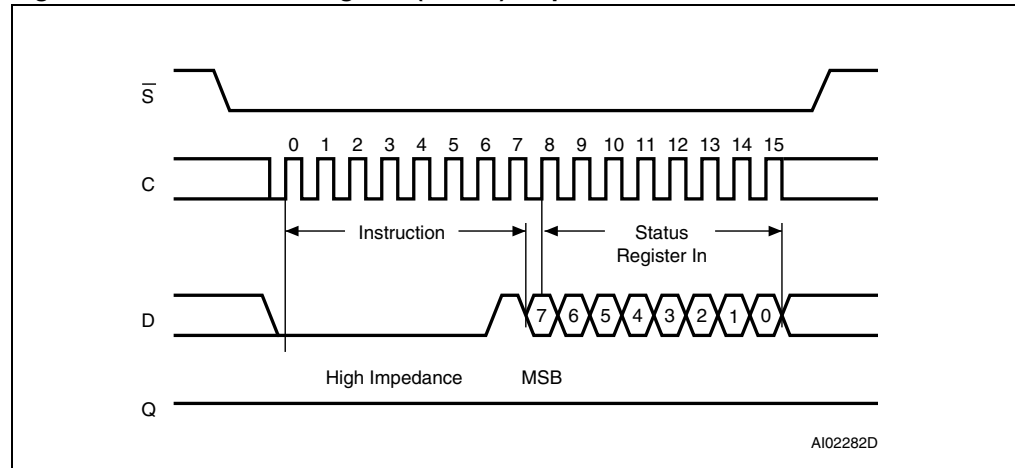
Figure 9. Write Status Register (WRSR) sequence

5.5 Read from Memory Array (READ)

As shown in [Figure 10](#), to send this instruction to the device, Chip Select (\bar{S}) is first driven low. The bits of the instruction byte and address bytes are then shifted in, on Serial Data input (D). The address is loaded into an internal address register, and the byte of data at that address is shifted out, on Serial Data output (Q).

If Chip Select (\bar{S}) continues to be driven low, the internal address register is automatically incremented, and the byte of data at the new address is shifted out.

When the highest address is reached, the address counter rolls over to zero, allowing the Read cycle to be continued indefinitely. The whole memory can, therefore, be read with a single READ instruction.

The Read cycle is terminated by driving Chip Select (\bar{S}) high. The rising edge of the Chip Select (\bar{S}) signal can occur at any time during the cycle.

The first byte addressed can be any byte within any page.

The instruction is not accepted, and is not executed, if a Write cycle is currently in progress.

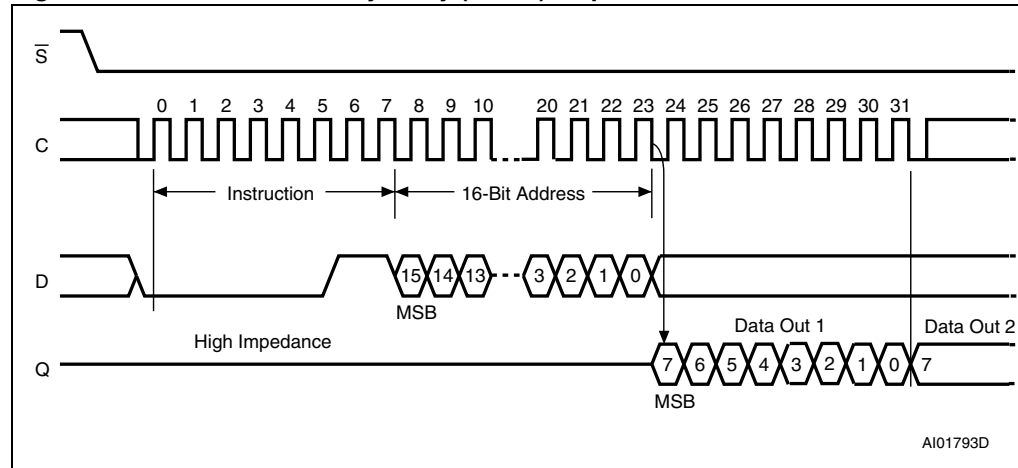
Figure 10. Read from Memory Array (READ) sequence

1. The most significant address bit (b15) is Don't Care.

5.6 Write to Memory Array (WRITE)

As shown in [Figure 11](#), to send this instruction to the device, Chip Select (\bar{S}) is first driven low. The bits of the instruction byte, address bytes, and at least one data byte are then shifted in, on Serial Data input (D). The instruction is terminated by driving Chip Select (\bar{S}) high at a byte boundary of the input data. The self-timed Write cycle, triggered by the rising edge of Chip Select (\bar{S}), continues for a period t_{WC} (as specified in [Table 17](#), [Table 18](#), [Table 19](#) and [Table 20](#).), at the end of which the Write in Progress (WIP) bit is reset to 0.

In the case of [Figure 11](#), Chip Select (\bar{S}) is driven high after the eighth bit of the data byte has been latched in, indicating that the instruction is being used to write a single byte. If, though, Chip Select (\bar{S}) continues to be driven low, as shown in [Figure 12](#), the next byte of input data is shifted in, so that more than a single byte, starting from the given address towards the end of the same page, can be written in a single internal Write cycle.

Each time a new data byte is shifted in, the least significant bits of the internal address counter are incremented. If the number of data bytes sent to the device exceeds the page boundary, the internal address counter rolls over to the beginning of the page, and the previous data there are overwritten with the incoming data. (The page size of these devices is 64 bytes).

The instruction is not accepted, and is not executed, under the following conditions:

- if the Write Enable Latch (WEL) bit has not been set to 1 (by executing a Write Enable instruction just before)
- if a Write cycle is already in progress
- if the device has not been deselected, by Chip Select (\bar{S}) being driven high, at a byte boundary (after the eighth bit, b0, of the last data byte that has been latched in)
- if the addressed page is in the region protected by the Block Protect (BP1 and BP0) bits.

Note: The self-timed Write cycle t_W is internally executed as a sequence of two consecutive events: [Erase addressed byte(s)], followed by [Program addressed byte(s)]. An erased bit is read as "0" and a programmed bit is read as "1".

Figure 11. Byte Write (WRITE) sequence

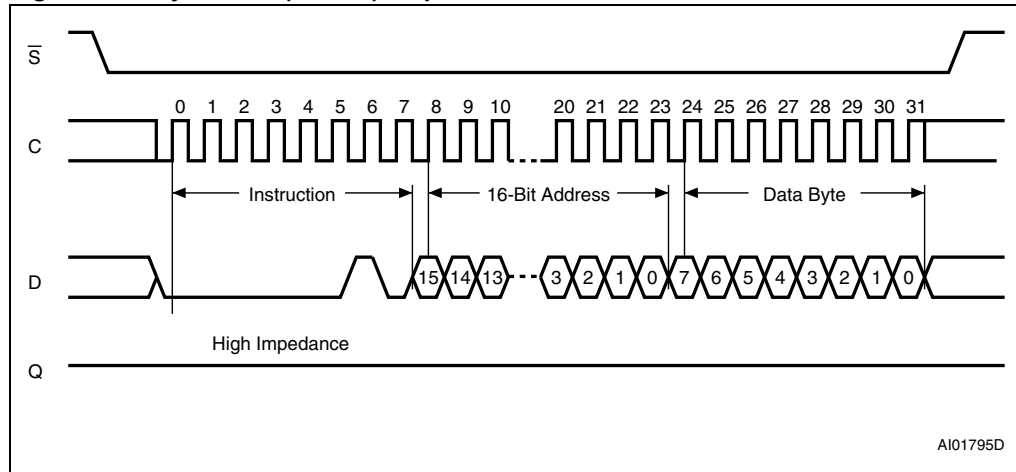

1. The most significant address bit (b15) is Don't Care.

Figure 12. Page Write (WRITE) sequence

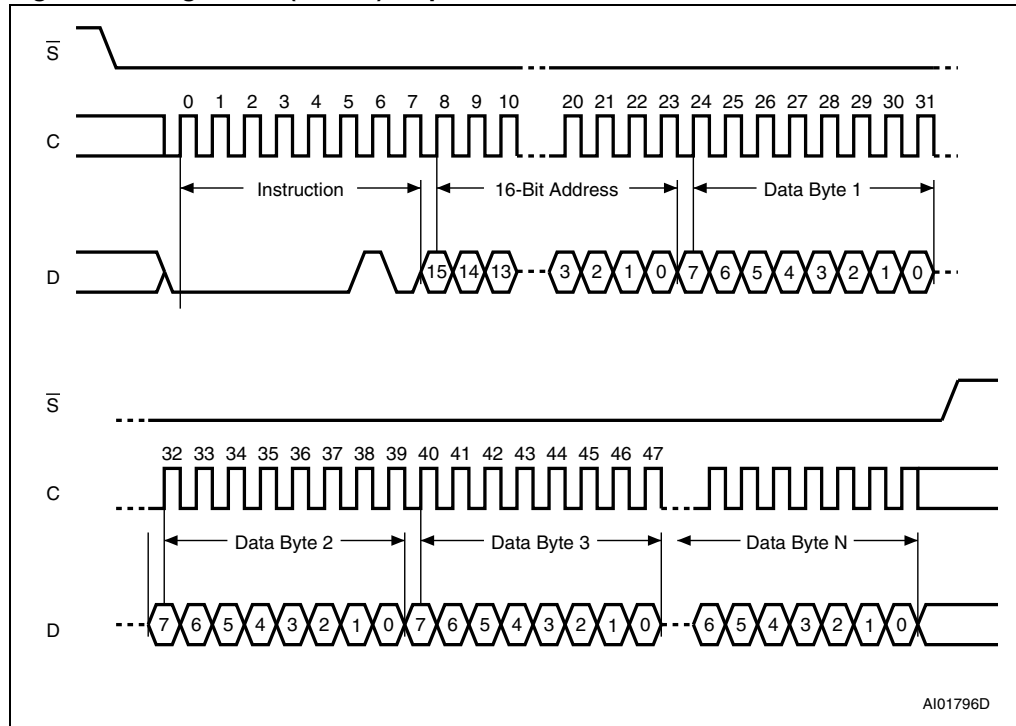

1. The most significant address bit (b15) is Don't Care.

5.6.1 ECC (error correction code) and Write cycling

The M95256 and M95256-D devices offer an ECC (error correction code) logic which compares each 4-byte word with its associated 6 EEPROM bits of ECC. As a result, if a single bit out of 4 bytes of data happens to be erroneous during a Read operation, the ECC detects it and replaces it by the correct value. The read reliability is therefore much improved by the use of this feature.

Note however that even if a single byte has to be written, 4 bytes are internally modified (plus the ECC bits). That is, the addressed byte is cycled together with the three other bytes making up the word. It is therefore recommended to write data word by word (4 bytes) at address $4 \cdot N$ (where N is an integer) in order to benefit from the larger amount of Write cycles.

The M95256 and M95256-D devices are qualified at 1 million (1 000 000) Write cycles, using a cycling routine that writes to the device in multiples of 4-byte words.

5.7 Read Identification Page (available only in M95256-DR devices)

The Identification Page (64 bytes) is an additional page which can be written and (later) permanently locked in Read-only mode.

Reading this page is achieved with the Read Identification Page instruction (see [Table 4](#)). The Chip Select signal (S) is first driven low, the bits of the instruction byte and address bytes are then shifted in, on Serial Data input (D). Address bit A10 must be 0, address bits [A15:A11] and [A9:A6] are Don't Care, and the data byte pointed to by [A5:A0] is shifted out on Serial Data output (Q). If Chip Select (S) continues to be driven low, the internal address register is automatically incremented, and the byte of data at the new address is shifted out.

The number of bytes to read in the ID page must not exceed the page boundary (e.g.: when reading the ID page from location 24d, the number of bytes should be less than or equal to 40d, as the ID page boundary is 64 bytes).

The read cycle is terminated by driving Chip Select (\bar{S}) high. The rising edge of the Chip Select (\bar{S}) signal can occur at any time during the cycle. The first byte addressed can be any byte within any page.

The instruction is not accepted, and is not executed, if a write cycle is currently in progress.

Figure 13. Read Identification Page sequence

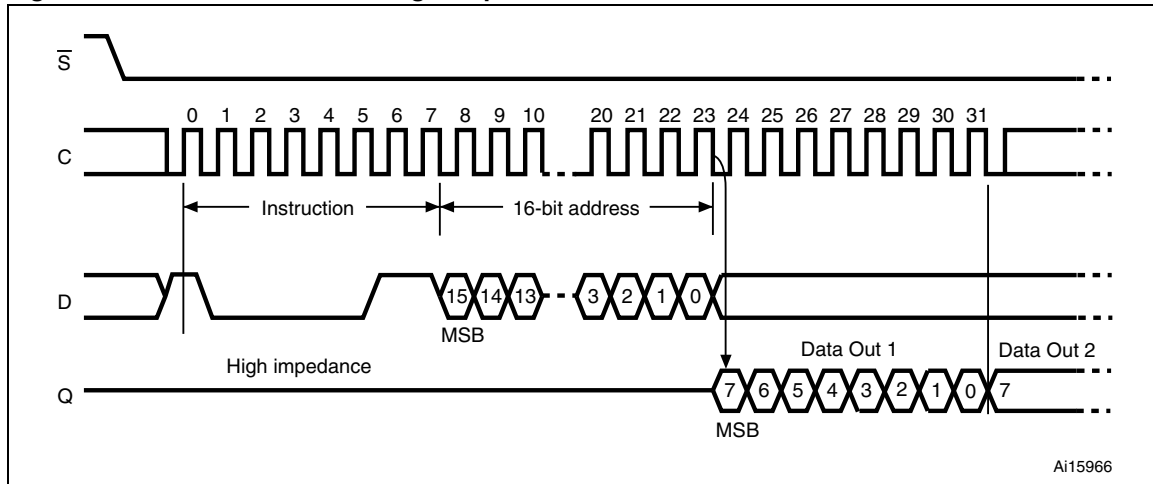

5.8 Write Identification Page

The Identification Page (256 bytes) is an additional page which can be written and (later) permanently locked in Read-only mode.

Writing this page is achieved with the Write Identification Page instruction (see [Table 4](#)), the Chip Select signal (S) is first driven low. The bits of the instruction byte, address byte, and at least one data byte are then shifted in on Serial Data input (D). Address bit A10 must be 0, address bits [A15:A11] and [A9:A6] are Don't Care, the [A5:A0] address bits define the byte address inside the identification page. The instruction sequence is shown in [Figure 14](#).

Figure 14. Write Identification Page sequence

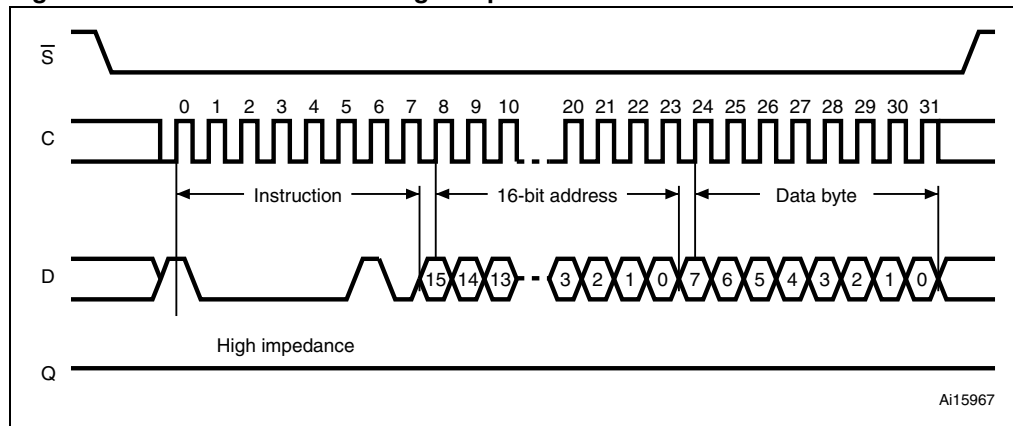

5.9 Read Lock Status (available only in M95256-DR devices)

The Read Lock Status instruction (see [Table 4](#)) allows to check if the Identification Page is locked (or not) in read-only mode. The Read Lock Status sequence is defined with the Chip Select (\bar{S}) first driven low. The bits of the instruction byte and address bytes are then shifted in on Serial Data input (D). Address bit A10 must be 1, all other address bits are Don't Care. The Lock bit is the LSB (least significant bit) of the byte read on Serial Data output (Q). It is at '1' when the lock is active and at '0' when the lock is not active. If Chip Select (\bar{S}) continues to be driven low, the same data byte is shifted out. The read cycle is terminated by driving Chip Select (\bar{S}) high.

The instruction sequence is shown in [Figure 15](#).

Figure 15. Read Lock Status sequence

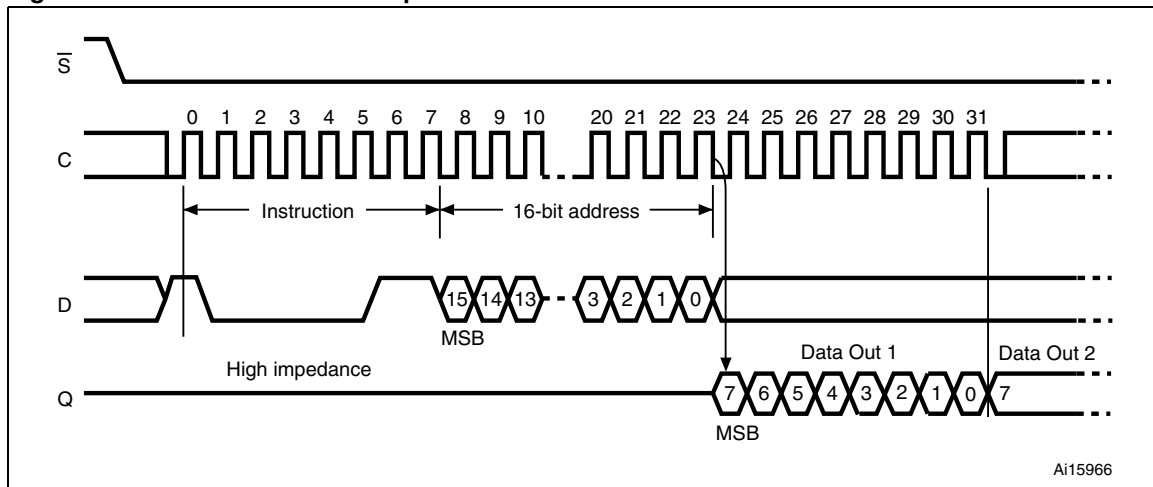

5.10 Lock ID (available only in M95256-DR devices)

The Lock ID instruction permanently locks the Identification Page in read-only mode. Before this instruction can be accepted, a Write Enable (WREN) instruction must have been executed. The Lock ID instruction is issued by driving Chip Select (\bar{S}) low, sending the instruction code, the address and a data byte on Serial Data input (D), and driving Chip Select (\bar{S}) high. In the address sent, A10 must be equal to 1, all other address bits are Don't Care. The data byte sent must be equal to the binary value xxxx xx1x, where x = Don't Care.

Chip Select (\bar{S}) must be driven high after the rising edge of Serial Clock (C) that latches in the eighth bit of the data byte, and before the next rising edge of Serial Clock (C). Otherwise, the Lock ID instruction is not executed.

Driving Chip Select (\bar{S}) high at a byte boundary of the input data triggers the self-timed write cycle whose duration is t_W (specified in [Table 20](#)). The instruction sequence is shown in [Figure 16](#).

The instruction is not accepted, and so not executed, under the following conditions:

- if the Write Enable Latch (WEL) bit has not been set to 1 (by previously executing a Write Enable instruction)
- if Status register bits (BP1,BP0) = (1,1)
- if a write cycle is already in progress
- if the device has not been deselected, by Chip Select (\bar{S}) being driven high, at a byte boundary (after the eighth bit, b0, of the last data byte that was latched in)
- if the Identification page is locked by the Lock Status bit

Figure 16. Lock ID sequence

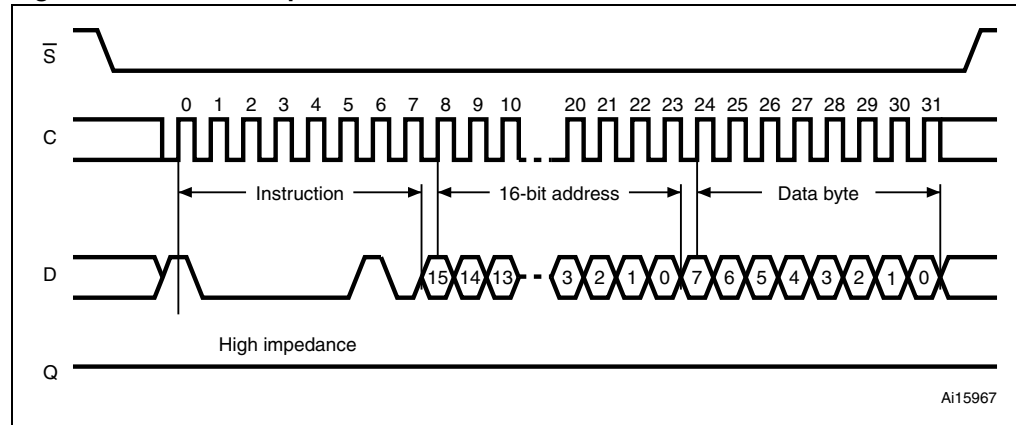

6 Delivery state

The device is delivered with the memory array set at all 1s (FFh). The Status Register Write Disable (SRWD) and Block Protect (BP1 and BP0) bits are initialized to 0.

7 Connecting to the SPI bus

These devices are fully compatible with the SPI protocol.

All instructions, addresses and input data bytes are shifted in to the device, most significant bit first. The Serial Data input (D) is sampled on the first rising edge of the Serial Clock (C) after Chip Select (\bar{S}) goes low.

All output data bytes are shifted out of the device, most significant bit first. The Serial Data output (Q) is latched on the first falling edge of the Serial Clock (C) after the instruction (such as the Read from Memory Array and Read Status Register instructions) have been clocked into the device.

Figure 17 shows an example of three memory devices connected to an MCU, on an SPI bus. Only one memory device is selected at a time, so only one memory device drives the Serial Data output (Q) line at a time, the other memory devices are high impedance.

Figure 17. Bus master and memory devices on the SPI bus

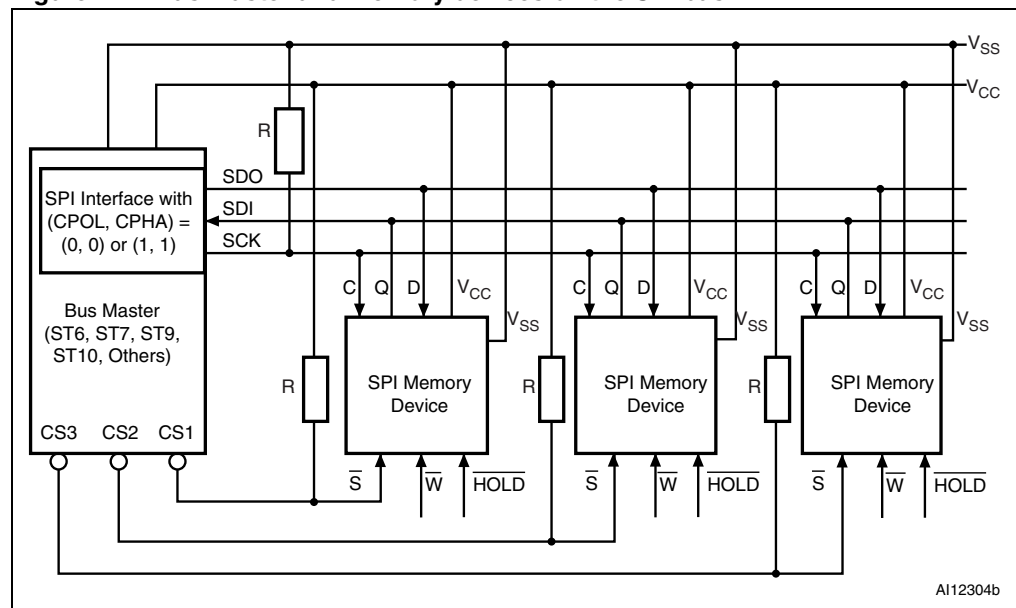

1. The Write Protect (\bar{W}) and Hold (\overline{HOLD}) signals should be driven, high or low as appropriate.

A pull-up resistor connected on each /S input (represented in *Figure 7*) ensures that each slave device on the SPI bus is not selected if the bus master leaves the /S line in the high impedance state.

In applications where the bus master might enter a state where all SPI bus inputs/outputs would be in high impedance at the same time (for example, if the bus master is reset during the transmission of an instruction), the clock line (C) must be connected to an external pull-down resistor so that, if all inputs/outputs become high impedance, the C line is pulled low (while the \bar{S} line is pulled high): this ensures that \bar{S} and C do not become high at the same time, and so, that the t_{SHCH} requirement is met. The typical value of R is 100 k Ω .

7.1 SPI modes

These devices can be driven by a microcontroller with its SPI peripheral running in either of the two following modes:

- CPOL=0, CPHA=0
- CPOL=1, CPHA=1

For these two modes, input data is latched in on the rising edge of Serial Clock (C), and output data is available from the falling edge of Serial Clock (C).

The difference between the two modes, as shown in [Figure 18](#), is the clock polarity when the bus master is in Stand-by mode and not transferring data:

- C remains at 0 for (CPOL=0, CPHA=0)
- C remains at 1 for (CPOL=1, CPHA=1)

Figure 18. SPI modes supported

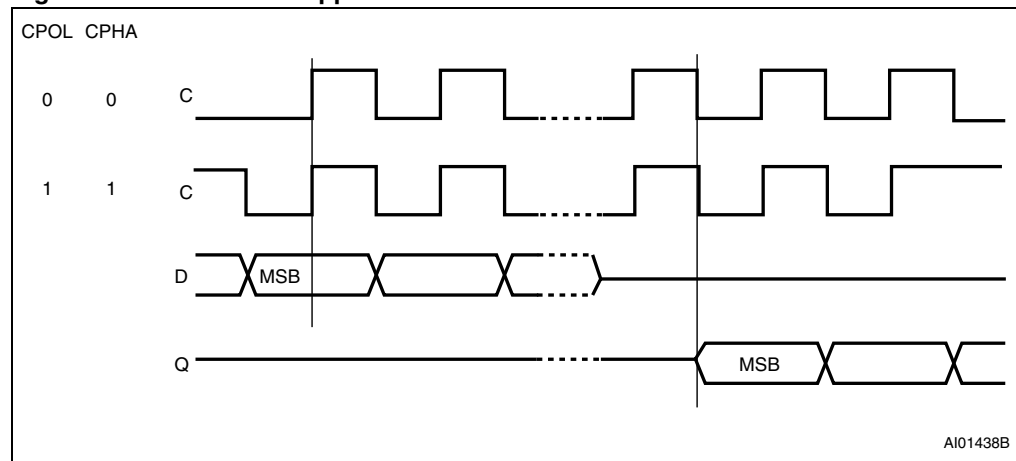

8 Maximum rating

Stressing the device outside the ratings listed in [Table 7](#) may cause permanent damage to the device. These are stress ratings only, and operation of the device at these, or any other conditions outside those indicated in the operating sections of this specification, is not implied. Exposure to absolute maximum rating conditions for extended periods may affect device reliability. Refer also to the STMicroelectronics SURE Program and other relevant quality documents.

Table 7. Absolute maximum ratings

| Symbol | Parameter | Min. | Max. | Unit |
|------------|---|-------------------------|---------------------|------|
| | Ambient temperature with power applied | -40 | 130 | °C |
| T_{STG} | Storage temperature | -65 | 150 | °C |
| T_{LEAD} | Lead temperature during soldering | see note ⁽¹⁾ | | °C |
| V_O | Output voltage | -0.50 | $V_{CC}+0.6$ | V |
| V_I | Input voltage | -0.50 | 6.5 | V |
| I_{OL} | DC output current (Q = 0) | - | 5 | mA |
| I_{OH} | DC output current (Q = 1) | -5 | - | mA |
| V_{CC} | Supply voltage | -0.50 | 6.5 | V |
| V_{ESD} | Electrostatic discharge voltage (human body model) ⁽²⁾ | | 4000 ⁽³⁾ | V |

1. Compliant with JEDEC Std J-STD-020D (for small body, Sn-Pb or Pb assembly), the ST ECOPACK® 7191395 specification, and the European directive on Restrictions on Hazardous Substances (RoHS) 2002/95/EU.
2. AEC-Q100-002 (compliant with JEDEC Std JESD22-A114, C1=100pF, R1=1500 Ω, R2=500 Ω)
3. V_{ESD} is 3000 V (max) for the M95256-D and the M95256 in MLP8 package MC.

9 DC and AC parameters

This section summarizes the operating and measurement conditions, and the DC and AC characteristics of the device. The parameters in the DC and AC characteristic tables that follow are derived from tests performed under the measurement conditions summarized in the relevant tables. Designers should check that the operating conditions in their circuit match the measurement conditions when relying on the quoted parameters.

Table 8. Operating conditions (M95256)

| Symbol | Parameter | Min. | Max. | Unit |
|----------|--|------|------|------|
| V_{CC} | Supply voltage | 4.5 | 5.5 | V |
| T_A | Ambient operating temperature (device grade 3) | -40 | 125 | °C |

Table 9. Operating conditions (M95256-W)

| Symbol | Parameter | Min. | Max. | Unit |
|----------|--|------|------|------|
| V_{CC} | Supply voltage | 2.5 | 5.5 | V |
| T_A | Ambient operating temperature (device grade 6) | -40 | 85 | °C |
| | Ambient operating temperature (device grade 3) | -40 | 125 | °C |

Table 10. Operating conditions (M95256-R and M95256-DR)

| Symbol | Parameter | Min. | Max. | Unit |
|----------|-------------------------------|------|------|------|
| V_{CC} | Supply voltage | 1.8 | 5.5 | V |
| T_A | Ambient operating temperature | -40 | 85 | °C |

Table 11. AC measurement conditions⁽¹⁾

| Symbol | Parameter | Min. | Max. | Unit |
|--------|--|------------------------------|------|------|
| C_L | Load capacitance | 30 or 100 ⁽²⁾ | | pF |
| | Input rise and fall times | | 25 | ns |
| | Input pulse voltages | 0.2 V_{CC} to 0.8 V_{CC} | | V |
| | Input and output timing reference voltages | 0.3 V_{CC} to 0.7 V_{CC} | | V |

1. Output Hi-Z is defined as the point where data out is no longer driven.
2. 100 pF when the clock frequency f_C is less than 10 MHz, 30 pF when the clock frequency f_C is equal to or greater than 10 MHz.

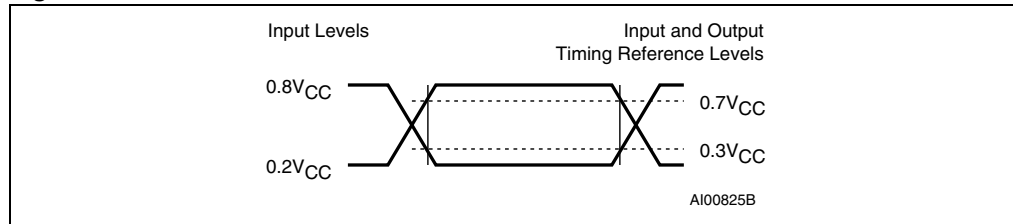
Figure 19. AC measurement I/O waveform**Table 12. Capacitance⁽¹⁾**

| Symbol | Parameter | Test condition | Max. | Unit |
|-----------|--------------------------------|------------------------|------|------|
| C_{OUT} | Output capacitance (Q) | $V_{OUT} = 0\text{ V}$ | 8 | pF |
| C_{IN} | Input capacitance (D) | $V_{IN} = 0\text{ V}$ | 8 | pF |
| | Input capacitance (other pins) | $V_{IN} = 0\text{ V}$ | 6 | pF |

1. Sampled only, not 100% tested.

Table 13. DC characteristics (M95256, device grade 3)

| Symbol | Parameter | Test conditions specified in Table 8 and Table 11 | Min. | Max. | Unit |
|----------------|-------------------------------------|--|--------------|--------------|---------------|
| I_{LI} | Input leakage current | $V_{IN} = V_{SS}$ or V_{CC} | | ± 2 | μA |
| I_{LO} | Output leakage current | $\bar{S} = V_{CC}$, $V_{OUT} = V_{SS}$ or V_{CC} | | ± 2 | μA |
| I_{CC} | Supply current | $C = 0.1V_{CC}/0.9V_{CC}$ at 5 MHz, $V_{CC} = 5\text{ V}$, Q = open | | 4 | mA |
| I_{CC1} | Supply current (Standby Power mode) | $\bar{S} = V_{CC}$, $V_{CC} = 5\text{ V}$, $V_{IN} = V_{SS}$ or V_{CC} | | 5 | μA |
| V_{IL} | Input low voltage | | -0.45 | $0.3 V_{CC}$ | V |
| V_{IH} | Input high voltage | | $0.7 V_{CC}$ | $V_{CC}+1$ | V |
| $V_{OL}^{(1)}$ | Output low voltage | $I_{OL} = 2\text{ mA}$, $V_{CC} = 5\text{ V}$ | | 0.4 | V |
| $V_{OH}^{(1)}$ | Output high voltage | $I_{OH} = -2\text{ mA}$, $V_{CC} = 5\text{ V}$ | $0.8 V_{CC}$ | | V |

1. For all 5 V range devices, the device meets the output requirements for both TTL and CMOS standards.

Table 14. DC characteristics (M95256-W, device grade 6)

| Symbol | Parameter | Test conditions specified in Table 9 (grade 6) and Table 11 | Min. | Max. | Unit |
|--------------------------|-------------------------------------|---|--------------|------------------|---------|
| I_{LI} | Input leakage current | $V_{IN} = V_{SS}$ or V_{CC} | | ± 2 | μA |
| I_{LO} | Output leakage current | $\bar{S} = V_{CC}$, $V_{OUT} = V_{SS}$ or V_{CC} | | ± 2 | μA |
| I_{CC} | Supply current (Read) | $V_{CC} = 2.5 V$, $C = 0.1V_{CC}/0.9V_{CC}$ at 5 MHz, Q = open | | 3 | mA |
| | | $V_{CC} = 2.5 V$, $C = 0.1V_{CC}/0.9V_{CC}$ at 10 MHz, Q = open | | 4 ⁽¹⁾ | mA |
| | | $V_{CC} = 5.5 V$, $C = 0.1V_{CC}/0.9V_{CC}$ at 5 MHz, Q = open | | 5 | mA |
| | | $V_{CC} = 5.5 V$, $C = 0.1V_{CC}/0.9V_{CC}$ at 20 MHz, Q = open | | 5 ⁽²⁾ | mA |
| I_{CC0} ⁽³⁾ | Supply current (Write) | During t_W , $\bar{S} = V_{CC}$, $2.5 V < V_{CC} < 5.5 V$ | | 5 | mA |
| I_{CC1} | Supply current (Standby Power mode) | $\bar{S} = V_{CC}$, $V_{CC} = 5.5 V$, $V_{IN} = V_{SS}$ or V_{CC} , | | 5 ⁽⁴⁾ | μA |
| | | $\bar{S} = V_{CC}$, $V_{CC} = 2.5 V$, $V_{IN} = V_{SS}$ or V_{CC} , | | 5 ⁽⁵⁾ | μA |
| V_{IL} | Input low voltage | | -0.45 | $0.3 V_{CC}$ | V |
| V_{IH} | Input high voltage | | $0.7 V_{CC}$ | $V_{CC}+1$ | V |
| V_{OL} | Output low voltage | $V_{CC} = 2.5 V$ and $I_{OL} = 1.5 mA$ or $V_{CC} = 5 V$ and $I_{OL} = 2 mA$ | | 0.4 | V |
| V_{OH} | Output high voltage | $V_{CC} = 2.5 V$ and $I_{OH} = -0.4 mA$ or $V_{CC} = 5 V$ and $I_{OH} = -2 mA$ | $0.8 V_{CC}$ | | V |

- 2 mA for the M95256-D and M95256 in MLP8 package MC
- For the M95256-D and M95256 in MLP8 package MC
- Characterized value, not tested in production.
- 3 μA for the M95256-D and M95256 in MLP8 package MC
- 2 μA for the M95256-D and M95256 in MLP8 package MC

Table 15. DC characteristics (M95256-W, device grade 3)

| Symbol | Parameter | Test conditions specified in Table 9 (grade 3) and Table 11 | Min. | Max. | Unit |
|-----------------|-------------------------------------|---|--------------|--------------|---------|
| I_{LI} | Input leakage current | $V_{IN} = V_{SS}$ or V_{CC} | | ± 2 | μA |
| I_{LO} | Output leakage current | $\bar{S} = V_{CC}$, $V_{OUT} = V_{SS}$ or V_{CC} | | ± 2 | μA |
| I_{CC} | Supply current (Read) | $C = 0.1V_{CC}/0.9V_{CC}$ at 5 MHz, $V_{CC} = 2.5$ V, $Q = \text{open}$ | | 3 | mA |
| $I_{CC0}^{(1)}$ | Supply current (Write) | During t_W , $\bar{S} = V_{CC}$, 2.5 V < V_{CC} < 5.5 V | | 6 | mA |
| I_{CC1} | Supply current (Standby Power mode) | $\bar{S} = V_{CC}$, $V_{IN} = V_{SS}$ or V_{CC} , 2.5 V < V_{CC} < 5.5 V | | 5 | μA |
| V_{IL} | Input low voltage | | -0.45 | $0.3 V_{CC}$ | V |
| V_{IH} | Input high voltage | | $0.7 V_{CC}$ | $V_{CC}+1$ | V |
| V_{OL} | Output low voltage | $I_{OL} = 1.5$ mA, $V_{CC} = 2.5$ V | | 0.4 | V |
| V_{OH} | Output high voltage | $I_{OH} = -0.4$ mA, $V_{CC} = 2.5$ V | $0.8 V_{CC}$ | | V |

1. Characterized value, not tested in production.

Table 16. DC characteristics (M95256-R, M95256-DR, device grade 6)

| Symbol | Parameter | Test conditions specified in Table 10 and Table 11 ⁽¹⁾ | Min | Max | Unit |
|-----------------|-------------------------------------|---|---------------|------------------|---------|
| I_{LI} | Input leakage current | $V_{IN} = V_{SS}$ or V_{CC} | | ± 2 | μA |
| I_{LO} | Output leakage current | $\bar{S} = V_{CC}$, $V_{OUT} = V_{SS}$ or V_{CC} | | ± 2 | μA |
| I_{CC} | Supply current (Read) | $V_{CC} = 1.8$ V, $C = 0.1V_{CC}/0.9V_{CC}$ at 2 MHz, $Q = \text{open}$ | | 1 ⁽²⁾ | mA |
| | | $V_{CC} = 1.8$ V, $C = 0.1V_{CC}/0.9V_{CC}$ at 5 MHz, $Q = \text{open}$ | | 2 ⁽³⁾ | |
| $I_{CC0}^{(4)}$ | Supply current (Write) | $V_{CC} = 1.8$ V, during t_W , $\bar{S} = V_{CC}$ | | 3 | mA |
| I_{CC1} | Supply current (Standby Power mode) | $V_{CC} = 1.8$ V, $\bar{S} = V_{CC}$, $V_{IN} = V_{SS}$ or V_{CC} | | 3 ⁽⁵⁾ | μA |
| V_{IL} | Input low voltage | 1.8 V $\leq V_{CC} < 2.5$ V | -0.45 | $0.25 V_{CC}$ | V |
| V_{IH} | Input high voltage | 1.8 V $\leq V_{CC} < 2.5$ V | $0.75 V_{CC}$ | $V_{CC}+1$ | V |
| V_{OL} | Output low voltage | $I_{OL} = 0.15$ mA, $V_{CC} = 1.8$ V | | 0.3 | V |
| V_{OH} | Output high voltage | $I_{OH} = -0.1$ mA, $V_{CC} = 1.8$ V | $0.8 V_{CC}$ | | V |

1. If the application uses the M95256-R, M95256-DR device with 2.5 V < V_{CC} < 5.5 V and -40 °C < T_A < $+85$ °C, please refer to [Table 14: DC characteristics \(M95256-W, device grade 6\)](#) instead of the above table.

2. 2 mA for the M95256-D and M95256 in MLP8 package MC

3. Only the M95256-D and M95256 in MLP8 package MC can run at 5 MHz (Preliminary data)

4. Characterized value, not tested in production.

5. 1 μA for the M95256-D and M95256 in MLP8 package MC

Table 17. AC characteristics (M95256, device grade 3)

| Test conditions specified in Table 8 and Table 11 | | | | | |
|---|------------|--|------|------|---------|
| Symbol | Alt. | Parameter | Min. | Max. | Unit |
| f_C | f_{SCK} | Clock frequency | D.C. | 5 | MHz |
| t_{SLCH} | t_{CSS1} | \overline{S} active setup time | 90 | | ns |
| t_{SHCH} | t_{CSS2} | \overline{S} not active setup time | 90 | | ns |
| t_{SHSL} | t_{CS} | \overline{S} deselect time | 100 | | ns |
| t_{CHSH} | t_{CSH} | \overline{S} active hold time | 90 | | ns |
| t_{CHSL} | | \overline{S} not active hold time | 90 | | ns |
| $t_{CH}^{(1)}$ | t_{CLH} | Clock high time | 90 | | ns |
| $t_{CL}^{(1)}$ | t_{CLL} | Clock low time | 90 | | ns |
| $t_{CLCH}^{(2)}$ | t_{RC} | Clock rise time | | 1 | μ s |
| $t_{CHCL}^{(2)}$ | t_{FC} | Clock fall time | | 1 | μ s |
| t_{DVCH} | t_{DSU} | Data in setup time | 20 | | ns |
| t_{CHDX} | t_{DH} | Data in hold time | 30 | | ns |
| t_{HHCH} | | Clock low hold time after \overline{HOLD} not active | 70 | | ns |
| t_{HLCH} | | Clock low hold time after \overline{HOLD} active | 40 | | ns |
| t_{CLHL} | | Clock low setup time before \overline{HOLD} active | 0 | | ns |
| t_{CLHH} | | Clock low setup time before \overline{HOLD} not active | 0 | | ns |
| $t_{SHQZ}^{(2)}$ | t_{DIS} | Output disable time | | 100 | ns |
| t_{CLQV} | t_V | Clock low to output valid | | 60 | ns |
| t_{CLQX} | t_{HO} | Output hold time | 0 | | ns |
| $t_{QLQH}^{(2)}$ | t_{RO} | Output rise time | | 50 | ns |
| $t_{QHQL}^{(2)}$ | t_{FO} | Output fall time | | 50 | ns |
| t_{HHQV} | t_{LZ} | \overline{HOLD} high to output valid | | 50 | ns |
| $t_{HLQZ}^{(2)}$ | t_{HZ} | \overline{HOLD} low to output High-Z | | 100 | ns |
| t_W | t_{WC} | Write time | | 5 | ms |

1. $t_{CH} + t_{CL}$ must never be less than the shortest possible clock period, $1 / f_C(\max)$

2. Value guaranteed by characterization, not tested in production.

Table 18. AC characteristics, M95256-W, device grade 6

| Test conditions specified in <i>Table 9</i> (grade 6) and <i>Table 11</i> | | | $C_L = 100 \text{ pF}$ | | M95256-D and M95256 in MLP8 package MC $C_L = 30 \text{ pF}$ | | | | Unit |
|--|------------|---|------------------------|------|--|------|---------------------|---------------------|---------------|
| Symbol | Alt. | Parameter | Min. | Max. | Min. | Max. | Min. ⁽¹⁾ | Max. ⁽¹⁾ | |
| f_C | f_{SCK} | Clock frequency | D.C. | 5 | D.C. | 10 | D.C. | 20 | MHz |
| t_{SLCH} | t_{CSS1} | \overline{S} active setup time | 90 | | 30 | | 15 | | ns |
| t_{SHCH} | t_{CSS2} | \overline{S} not active setup time | 90 | | 30 | | 15 | | ns |
| t_{SHSL} | t_{CS} | \overline{S} deselect time | 100 | | 40 | | 20 | | ns |
| t_{CHSH} | t_{CSH} | \overline{S} active hold time | 90 | | 30 | | 15 | | ns |
| t_{CHSL} | | \overline{S} not active hold time | 90 | | 30 | | 15 | | ns |
| $t_{CH}^{(2)}$ | t_{CLH} | Clock high time | 90 | | 40 | | 20 | | ns |
| $t_{CL}^{(1)}$ | t_{CLL} | Clock low time | 90 | | 40 | | 20 | | ns |
| $t_{CLCH}^{(3)}$ | t_{RC} | Clock rise time | | 1 | | 2 | | 2 | μs |
| $t_{CHCL}^{(2)}$ | t_{FC} | Clock fall time | | 1 | | 2 | | 2 | μs |
| t_{DVCH} | t_{DSU} | Data in setup time | 20 | | 10 | | 5 | | ns |
| t_{CHDX} | t_{DH} | Data in hold time | 30 | | 10 | | 10 | | ns |
| t_{HHCH} | | Clock low hold time after HOLD not active | 70 | | 30 | | 15 | | ns |
| t_{HLCH} | | Clock low hold time after HOLD active | 40 | | 30 | | 15 | | ns |
| t_{CLHL} | | Clock low setup time before HOLD active | 0 | | 0 | | 0 | | ns |
| t_{CLHH} | | Clock low setup time before HOLD not active | 0 | | 0 | | 0 | | ns |
| $t_{SHQZ}^{(2)}$ | t_{DIS} | Output disable time | | 100 | | 40 | | 20 | ns |
| t_{CLQV} | t_V | Clock low to output valid | | 60 | | 40 | | 20 | ns |
| t_{CLQX} | t_{HO} | Output hold time | 0 | | 0 | | 0 | | ns |
| $t_{QLQH}^{(2)}$ | t_{RO} | Output rise time | | 50 | | 40 | | 20 | ns |
| $t_{QHQL}^{(2)}$ | t_{FO} | Output fall time | | 50 | | 40 | | 20 | ns |
| t_{HHQV} | t_{LZ} | HOLD high to output valid | | 50 | | 40 | | 20 | ns |
| $t_{HLQZ}^{(2)}$ | t_{HZ} | HOLD low to output High-Z | | 100 | | 40 | | 20 | ns |
| t_W | t_{WC} | Write time | | 5 | | 5 | | 5 | ms |

1. $4.5 \text{ V} \leq V_{CC} \leq 5.5 \text{ V}$

2. $t_{CH} + t_{CL}$ must never be less than the shortest possible clock period, $1 / f_C(\text{max})$.

3. Value guaranteed by characterization, not tested in production.

Table 19. AC characteristics (M95256-W, device grade 3)

| Test conditions specified in Table 9 (grade 6) and Table 11 | | | | | |
|---|------------|--|------|------|---------|
| Symbol | Alt. | Parameter | Min. | Max. | Unit |
| f_C | f_{SCK} | Clock frequency | D.C. | 5 | MHz |
| t_{SLCH} | t_{CSS1} | \overline{S} active setup time | 90 | | ns |
| t_{SHCH} | t_{CSS2} | \overline{S} not active setup time | 90 | | ns |
| t_{SHSL} | t_{CS} | \overline{S} deselect time | 100 | | ns |
| t_{CHSH} | t_{CSH} | \overline{S} active hold time | 90 | | ns |
| t_{CHSL} | | \overline{S} not active hold time | 90 | | ns |
| $t_{CH}^{(1)}$ | t_{CLH} | Clock high time | 90 | | ns |
| $t_{CL}^{(1)}$ | t_{CLL} | Clock low time | 90 | | ns |
| $t_{CLCH}^{(2)}$ | t_{RC} | Clock rise time | | 1 | μ s |
| $t_{CHCL}^{(2)}$ | t_{FC} | Clock fall time | | 1 | μ s |
| t_{DVCH} | t_{DSU} | Data in setup time | 20 | | ns |
| t_{CHDX} | t_{DH} | Data in hold time | 30 | | ns |
| t_{HHCH} | | Clock low hold time after \overline{HOLD} not active | 70 | | ns |
| t_{HLCH} | | Clock low hold time after \overline{HOLD} active | 40 | | ns |
| t_{CLHL} | | Clock low setup time before \overline{HOLD} active | 0 | | ns |
| t_{CLHH} | | Clock low setup time before \overline{HOLD} not active | 0 | | ns |
| $t_{SHQZ}^{(2)}$ | t_{DIS} | Output disable time | | 100 | ns |
| t_{CLQV} | t_V | Clock low to output valid | | 60 | ns |
| t_{CLQX} | t_{HO} | Output hold time | 0 | | ns |
| $t_{QLQH}^{(2)}$ | t_{RO} | Output rise time | | 50 | ns |
| $t_{QHQL}^{(2)}$ | t_{FO} | Output fall time | | 50 | ns |
| t_{HHQV} | t_{LZ} | \overline{HOLD} high to output valid | | 50 | ns |
| $t_{HLQZ}^{(2)}$ | t_{HZ} | \overline{HOLD} low to output High-Z | | 100 | ns |
| t_W | t_{WC} | Write time | | 5 | ms |

1. $t_{CH} + t_{CL}$ must never be less than the shortest possible clock period, $1 / f_C(\max)$

2. Value guaranteed by characterization, not tested in production.

Table 20. AC characteristics (M95256-DR, M95256-R device grade 6)

| Test conditions specified in Table 10 and Table 11 | | | | | | | |
|--|------------|--|------------------------------------|------|--------------------------------|------|---------|
| Symbol | Alt. | Parameter | Min. | Max. | Min. | Max. | Unit |
| | | | Current ⁽¹⁾ products | | New products ⁽²⁾ | | |
| f_C | f_{SCK} | Clock frequency | D.C. | 2 | D.C. | 5 | MHz |
| t_{SLCH} | t_{CSS1} | \overline{S} active setup time | 200 | | 60 | | ns |
| t_{SHCH} | t_{CSS2} | \overline{S} not active setup time | 200 | | 60 | | ns |
| t_{SHSL} | t_{CS} | \overline{S} deselect time | 200 | | 90 | | ns |
| t_{CHSH} | t_{CSH} | \overline{S} active hold time | 200 | | 60 | | ns |
| t_{CHSL} | | \overline{S} not active hold time | 200 | | 60 | | ns |
| $t_{CH}^{(3)}$ | t_{CLH} | Clock high time | 200 | | 80 | | ns |
| $t_{CL}^{(3)}$ | t_{CLL} | Clock low time | 200 | | 80 | | ns |
| $t_{CLCH}^{(4)}$ | t_{RC} | Clock rise time | | 1 | | 2 | μs |
| $t_{CHCL}^{(4)}$ | t_{FC} | Clock fall time | | 1 | | 2 | μs |
| t_{DVCH} | t_{DSU} | Data in setup time | 40 | | 20 | | ns |
| t_{CHDX} | t_{DH} | Data in hold time | 50 | | 20 | | ns |
| t_{HHCH} | | Clock low hold time after \overline{HOLD} not active | 140 | | 60 | | ns |
| t_{HLCH} | | Clock low hold time after \overline{HOLD} active | 90 | | 60 | | ns |
| t_{CLHL} | | Clock low setup time before \overline{HOLD} active | 0 | | 0 | | ns |
| t_{CLHH} | | Clock low setup time before \overline{HOLD} not active | 0 | | 0 | | ns |
| $t_{SHQZ}^{(4)}$ | t_{DIS} | Output disable time | | 250 | | 80 | ns |
| t_{CLQV} | t_V | Clock low to output valid | | 150 | | 80 | ns |
| t_{CLQX} | t_{HO} | Output hold time | 0 | | 0 | | ns |
| $t_{QLQH}^{(4)}$ | t_{RO} | Output rise time | | 100 | | 20 | ns |
| $t_{QHQL}^{(4)}$ | t_{FO} | Output fall time | | 100 | | 20 | ns |
| t_{HHQV} | t_{LZ} | \overline{HOLD} high to output valid | | 100 | | 80 | ns |
| $t_{HLQZ}^{(4)}$ | t_{HZ} | \overline{HOLD} low to output High-Z | | 250 | | 80 | ns |
| t_W | t_{WC} | Write time | | 5 | | 5 | ms |

1. Current products are identified by process letters "AB".
2. New products are the M95256-D and M95256 in MLP8 package MC. For these new products, the test flow guarantees the AC parameter values defined in this table (when $V_{CC} = 1.8$ V) and the AC parameter values defined in [Table 18](#) (when $V_{CC} = 2.5$ V or $V_{CC} = 5.0$ V).
3. $t_{CH} + t_{CL}$ must never be less than the shortest possible clock period, $1 / f_C(\max)$.
4. Value guaranteed by characterization, not 100% tested in production.

Figure 20. Serial input timing

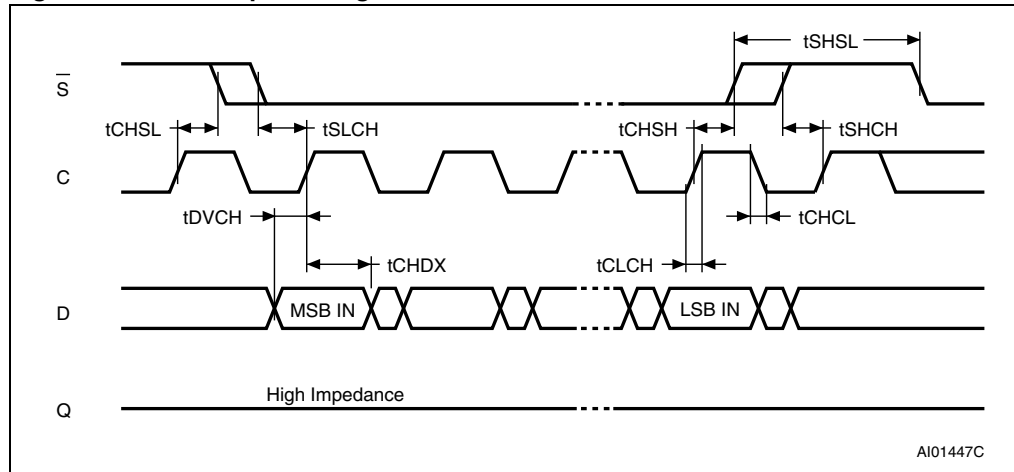

Figure 21. Hold timing

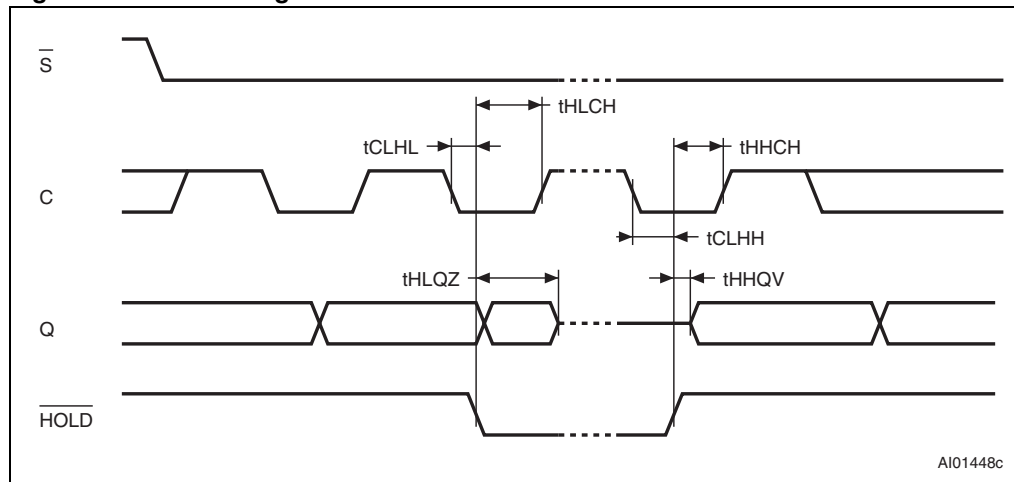
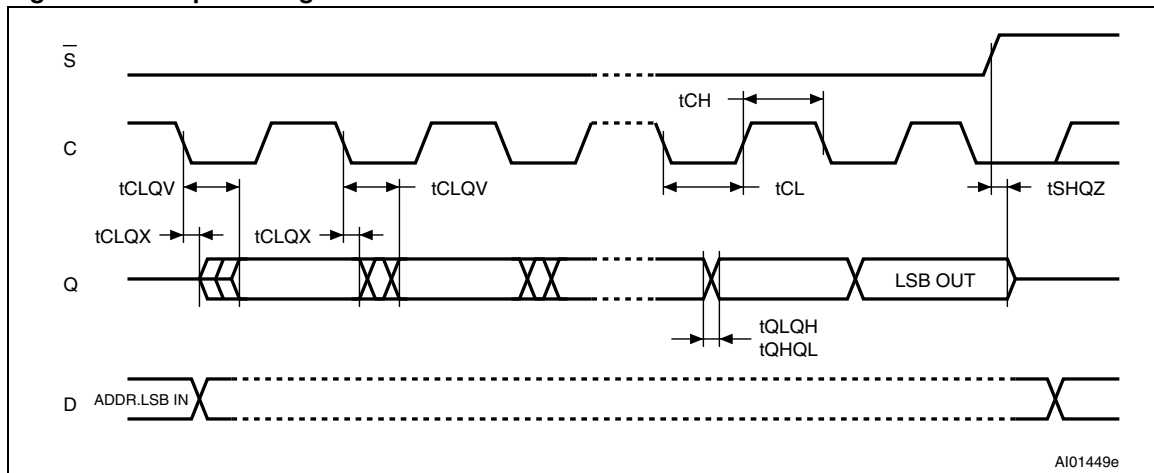

Figure 22. Output timing



10 Package mechanical data

In order to meet environmental requirements, ST offers the M95256 in ECOPACK® packages. These packages have a lead-free second level interconnect. The category of second level interconnect is marked on the package and on the inner box label, in compliance with JEDEC Standard JESD97. The maximum ratings related to soldering conditions are also marked on the inner box label. ECOPACK is an ST trademark. ECOPACK specifications are available at www.st.com.

Figure 23. SO8N – 8 lead plastic small outline, 150 mils body width, package outline

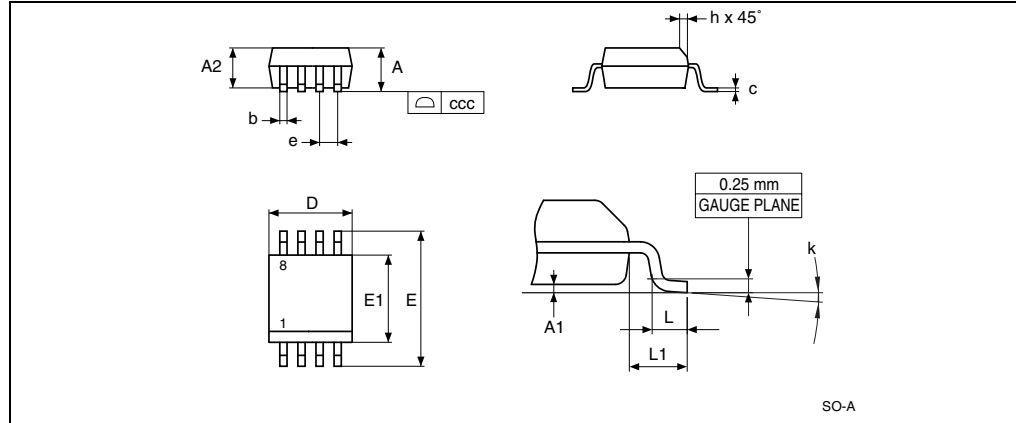

1. Drawing is not to scale.

Table 21. SO8N – 8 lead plastic small outline, 150 mils body width, package data

| Symbol | millimeters | | | inches ⁽¹⁾ | | |
|--------|-------------|------|------|-----------------------|--------|--------|
| | Typ | Min | Max | Typ | Min | Max |
| A | | | 1.75 | | | 0.0689 |
| A1 | | 0.1 | 0.25 | | 0.0039 | 0.0098 |
| A2 | | 1.25 | | | 0.0492 | |
| b | | 0.28 | 0.48 | | 0.011 | 0.0189 |
| c | | 0.17 | 0.23 | | 0.0067 | 0.0091 |
| ccc | | | 0.1 | | | 0.0039 |
| D | 4.9 | 4.8 | 5 | 0.1929 | 0.189 | 0.1969 |
| E | 6 | 5.8 | 6.2 | 0.2362 | 0.2283 | 0.2441 |
| E1 | 3.9 | 3.8 | 4 | 0.1535 | 0.1496 | 0.1575 |
| e | 1.27 | - | - | 0.05 | - | - |
| h | | 0.25 | 0.5 | | 0.0098 | 0.0197 |
| k | | 0° | 8° | | 0° | 8° |
| L | | 0.4 | 1.27 | | 0.0157 | 0.05 |
| L1 | 1.04 | | | 0.0409 | | |

1. Values in inches are converted from mm and rounded to 4 decimal digits.

Figure 24. TSSOP8 – 8 lead thin shrink small outline, package outline

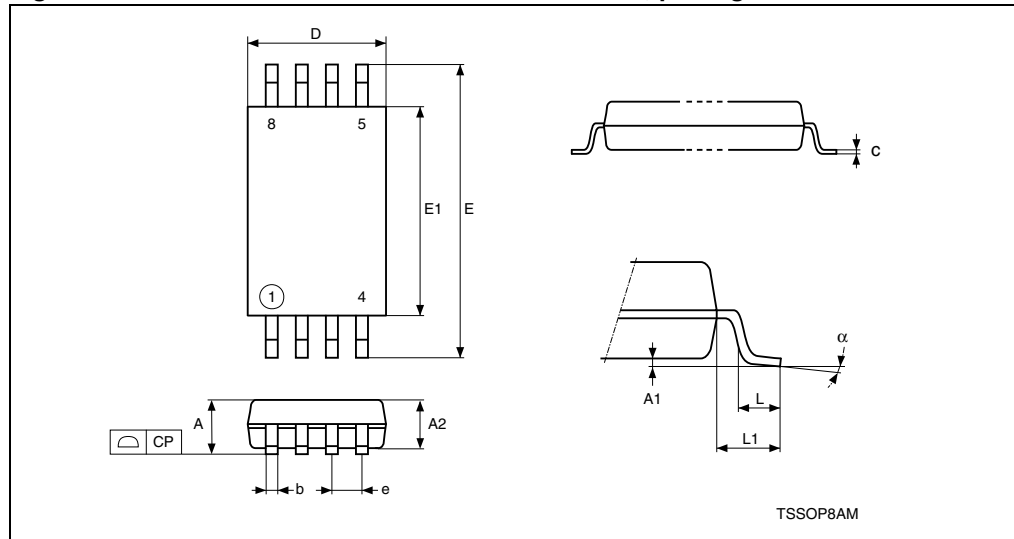

1. Drawing is not to scale.

Table 22. TSSOP8 – 8 lead thin shrink small outline, package mechanical data

| Symbol | millimeters | | | inches ⁽¹⁾ | | |
|----------|-------------|-------|-------|-----------------------|--------|--------|
| | Typ | Min | Max | Typ | Min | Max |
| A | | | 1.200 | | | 0.0472 |
| A1 | | 0.050 | 0.150 | | 0.0020 | 0.0059 |
| A2 | 1.000 | 0.800 | 1.050 | 0.0394 | 0.0315 | 0.0413 |
| b | | 0.190 | 0.300 | | 0.0075 | 0.0118 |
| c | | 0.090 | 0.200 | | 0.0035 | 0.0079 |
| CP | | | 0.100 | | | 0.0039 |
| D | 3.000 | 2.900 | 3.100 | 0.1181 | 0.1142 | 0.1220 |
| e | 0.650 | – | – | 0.0256 | – | – |
| E | 6.400 | 6.200 | 6.600 | 0.2520 | 0.2441 | 0.2598 |
| E1 | 4.400 | 4.300 | 4.500 | 0.1732 | 0.1693 | 0.1772 |
| L | 0.600 | 0.450 | 0.750 | 0.0236 | 0.0177 | 0.0295 |
| L1 | 1.000 | | | 0.0394 | | |
| α | | 0° | 8° | | 0° | 8° |
| N | | 8 | | | 8 | |

1. Values in inches are converted from mm and rounded to 4 decimal digits.

**Figure 25. UFDFPN8 (MLP8) – 8-lead ultra thin fine pitch dual flat package no lead
2 × 3mm, package outline**

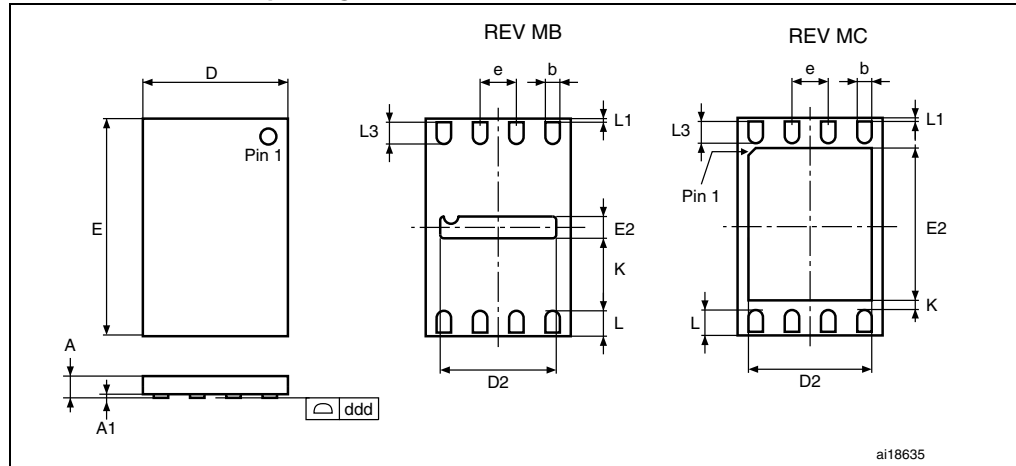

1. Drawing is not to scale.
2. The central pad (E2 × D2 area in the above illustration) is internally pulled to V_{SS}. It must not be allowed to be connected to any other voltage or signal line on the PCB, for example during the soldering process.
3. The circle in the top view of the package indicates the position of pin 1.

**Table 23. UFDFPN8 (MLP8) 8-lead ultra thin fine pitch dual flat package no lead
2 x 3 mm, data**

| Symbol | millimeters | | | inches ⁽¹⁾ | | |
|--------------------|-------------|-------|-------|-----------------------|--------|--------|
| | Typ | Min | Max | Typ | Min | Max |
| A | 0.550 | 0.450 | 0.600 | 0.0217 | 0.0177 | 0.0236 |
| A1 | 0.020 | 0 | 0.050 | 0.0008 | 0 | 0.0020 |
| b | 0.250 | 0.200 | 0.300 | 0.0098 | 0.0079 | 0.0118 |
| D | 2.000 | 1.900 | 2.100 | 0.0787 | 0.0748 | 0.0827 |
| D2 (rev MB) | 1.600 | 1.500 | 1.700 | 0.0630 | 0.0591 | 0.0669 |
| D2 (rev MC) | | 1.200 | 1.600 | | 0.0472 | 0.0630 |
| E | 3.000 | 2.900 | 3.100 | 0.1181 | 0.1142 | 0.1220 |
| E2 (rev MB) | 0.200 | 0.100 | 0.300 | 0.0079 | 0.0039 | 0.0118 |
| E2 (rev MC) | | 1.20 | 1.6 | | 0.0472 | 0.0630 |
| e | 0.500 | - | - | 0.0197 | - | - |
| K | - | 0.300 | - | - | 0.0118 | - |
| L | - | 0.300 | 0.500 | - | 0.0118 | 0.0197 |
| L1 | - | - | 0.150 | - | - | 0.0059 |
| L3 | | 0.300 | - | - | 0.0118 | - |
| ddd ⁽²⁾ | 0.050 | - | - | 0.0020 | - | - |

1. Values in inches are converted from mm and rounded to 4 decimal digits.
2. Applied for exposed die paddle and terminals. Exclude embedding part of exposed die paddle from measuring.

Figure 26. M95256-DR WLCSP, 0.5 mm pitch, package outline

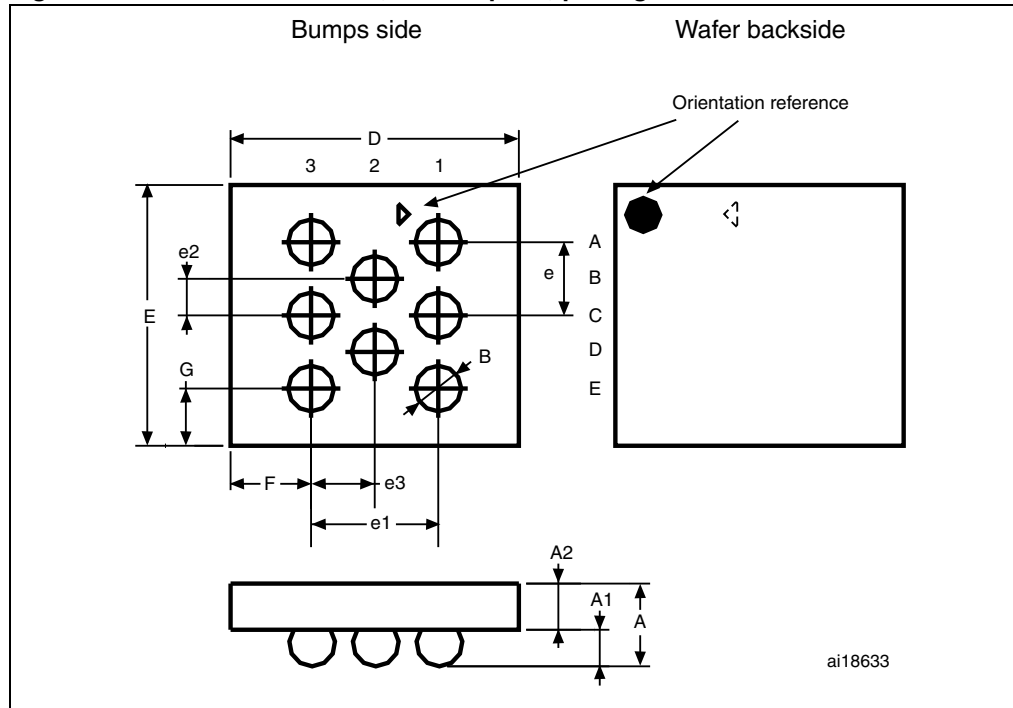

1. Drawing is not to scale.

Table 24. M95256-DR WLCSP, 0.5 mm pitch, package mechanical data

| Symbol | Millimeters | | | Inches ⁽¹⁾ | | |
|------------------|-------------|-------|-------|-----------------------|--------|--------|
| | Typ | Min | Max | Typ | Min | Max |
| A | 0.60 | 0.55 | 0.65 | 0.0236 | 0.0217 | 0.0256 |
| A1 | 0.245 | 0.22 | 0.27 | 0.0096 | 0.0087 | 0.0106 |
| A2 | 0.355 | 0.330 | 0.380 | 0.0140 | 0.0130 | 0.0150 |
| B | Ø 0.311 | | | Ø 0.0122 | | |
| D | 1.97 | 1.95 | 1.99 | 0.0776 | 0.0768 | 0.0783 |
| E | 1.785 | 1.765 | 1.805 | 0.0703 | 0.0695 | 0.0711 |
| e | 0.5 | | | 0.0197 | | |
| e1 | 0.866 | | | 0.0341 | | |
| e2 | 0.25 | | | 0.0098 | | |
| e3 | 0.433 | | | 0.0170 | | |
| F | 0.552 | 0.502 | 0.602 | 0.0217 | 0.0198 | 0.0237 |
| G | 0.392 | 0.342 | 0.442 | 0.0154 | 0.0135 | 0.0174 |
| N ⁽²⁾ | 8 | | | 8 | | |

1. Values in inches are converted from mm and rounded to 4 decimal digits.

2. N is the total number of terminals.

11 Part numbering

Table 25. Ordering information scheme

| | | | | | | | | |
|---------------------------|---|---|---|----|---|---|---|----|
| Example: | M95256 | - | W | MN | 6 | T | P | /A |
| Device type | M95 = SPI serial access EEPROM | | | | | | | |
| Device function | 256 = 256 Kbit 256-D = 256 Kbit plus Identification page | | | | | | | |
| Operating voltage | blank = $V_{CC} = 4.5$ to 5.5 V W = $V_{CC} = 2.5$ to 5.5 V R = $V_{CC} = 1.8$ to 5.5 V | | | | | | | |
| Package | MN = SO8 (150 mils width) DW = TSSOP8 (169 mils width) CS = WLCSP MB, MC = UFDFPN8 (MLP8) | | | | | | | |
| Device grade | 6 = Industrial temperature range, -40 to 85 °C. Device tested with standard test flow 3 = Device tested with High Reliability Certified Flow ⁽¹⁾ Automotive temperature range (-40 to 125 °C) | | | | | | | |
| Option | blank = Standard packing T = Tape and reel packing | | | | | | | |
| Plating technology | P or G = ECOPACK [®] (RoHs compliant) | | | | | | | |
| Process | A or AB = F8L ⁽²⁾ | | | | | | | |

1. ST strongly recommends the use of the Automotive Grade devices for use in an automotive environment. The High Reliability Certified Flow (HRCF) is described in the quality note QNEE9801. Please ask your nearest ST sales office for a copy.
2. Used only for device grade 3 and WLCSP packages.

For a list of available options (speed, package, etc.) or for further information on any aspect of this device, please contact your nearest ST Sales Office. The category of second-level interconnect is marked on the package and on the inner box label, in compliance with JEDEC Standard JESD97. The maximum ratings related to soldering conditions are also marked on the inner box label.

12 Revision history

Table 26. Document revision history

| Date | Revision | Changes |
|-------------|----------|--|
| 17-Nov-1999 | 2.1 | New -V voltage range added (including the tables for DC characteristics, AC characteristics, and ordering information). |
| 07-Feb-2000 | 2.2 | New -V voltage range extended to M95256 (including AC characteristics, and ordering information). |
| 22-Feb-2000 | 2.3 | tCLCH and tCHCL, for the M95xxx-V, changed from 1 μ s to 100ns |
| 15-Mar-2000 | 2.4 | -V voltage range changed to 2.7-3.6V |
| 29-Jan-2001 | 2.5 | Lead Soldering Temperature in the Absolute Maximum Ratings table amended Illustrations and Package Mechanical data updated |
| 12-Jun-2001 | 2.6 | Correction to header of Table 12B TSSOP14 Illustrations and Package Mechanical data updated Document promoted from Preliminary Data to Full Data Sheet |
| 08-Feb-2002 | 2.7 | Announcement made of planned upgrade to 10 MHz clock for the 5V, -40 to 85°C, range. |
| 09-Aug-2002 | 2.8 | M95128 split off to its own datasheet. Data added for new and forthcoming products, including availability of the SO8 narrow package. |
| 24-Feb-2003 | 2.9 | Omission of SO8 narrow package mechanical data remedied |
| 26-Jun-2003 | 2.10 | -V voltage range removed |
| 21-Nov-2003 | 3.0 | Table of contents, and Pb-free options added. -S voltage range extended to -R. $V_{IL}(\text{min})$ improved to -0.45V |
| 17-Mar-2004 | 4.0 | Absolute Maximum Ratings for $V_{IO}(\text{min})$ and $V_{CC}(\text{min})$ changed. Soldering temperature information clarified for RoHS compliant devices. Device grade information clarified |
| 21-Oct-2004 | 5.0 | M95128 datasheet merged back in. Product List summary table added. AEC-Q100-002 compliance. Device Grade information clarified. tHHQX corrected to tHHQV. 10MHz product becomes standard |

Table 26. Document revision history (continued)

| Date | Revision | Changes |
|-------------|----------|--|
| 13-Apr-2006 | 6 | <p>M95128 part numbers removed from document. PDIP8 package removed. <i>Delivery state</i> paragraph added.</p> <p><i>Section 3.8: Operating supply voltage (VCC)</i> added and information removed below <i>Section 4: Operating features</i>.</p> <p>Power up state removed below <i>Section 6: Delivery state</i>.</p> <p><i>Figure 18: SPI modes supported</i> modified and <i>Note 2</i> added.</p> <p><i>Note 1</i> added to <i>Table 8</i>.</p> <p>I_{CC1} specified over the whole V_{CC} range and I_{CC0} added in <i>Table 14</i>, <i>Table 15</i> and <i>Table 16</i>. I_{CC} specified over the whole V_{CC} range in <i>Table 14</i>.</p> <p><i>Table 17: AC Characteristics (M95256, Device Grade 6)</i> added.</p> <p>t_{CHHL} and t_{CHHH} replaced by t_{CLHL} and t_{CLHH}, respectively.</p> <p><i>Figure 21: Hold timing</i> modified. <i>Process</i> added to <i>Table 25: Ordering information scheme</i>. <i>Note 1</i> added to <i>Table 25</i>.</p> <p><i>Note 1</i> removed from <i>Table 20: AC characteristics (M95256-DR, M95256-R device grade 6)</i>.</p> <p>T_A added to <i>Table 7: Absolute maximum ratings</i>.</p> <p>Order of sections modified.</p> |
| 15-Oct-2007 | 7 | <p>M95256 with device grade 6 temperature range removed.</p> <p><i>Section 3.7: VSS ground</i> added, <i>Section 3.8: Operating supply voltage (VCC)</i> modified. Small text changes.</p> <p><i>Section 5.4: Write Status Register (WRSR)</i>, <i>Section 5.5: Read from Memory Array (READ)</i> and <i>Section 6: Delivery state</i> updated.</p> <p><i>Note 2</i> below <i>Figure 17: Bus master and memory devices on the SPI bus</i> removed, replaced by explanatory paragraph.</p> <p>T_{LEAD} added to <i>Table 7: Absolute maximum ratings</i>.</p> <p>Test conditions modified for I_{CC0} and I_{CC1}, and V_{IH} min modified in <i>Table 17: AC characteristics (M95256, device grade 3)</i>.</p> <p>t_W modified and "preliminary data" note removed in <i>Table 20: AC characteristics (M95256-DR, M95256-R device grade 6)</i>.</p> <p>Blank option removed below Plating technology, process A modified and process V removed in <i>Table 25: Ordering information scheme</i>.</p> <p><i>Table 26: Available M95256x products (package, voltage range, temperature grade)</i> added.</p> <p>SO8N and SO8W package specifications updated (see <i>Section 10: Package mechanical data</i>). Package mechanical data: inches calculated from mm and rounded to 3 decimal digits.</p> |
| 27-Mar-2008 | 8 | <p><i>Section 3.8: Operating supply voltage (VCC)</i> modified. Small text changes.</p> <p>Frequency corrected <i>on page 1</i>.</p> <p>V_{IL} and V_{IH} modified in <i>Table 16: DC characteristics (M95256-R, M95256-DR, device grade 6)</i>.</p> <p>AB Process added to <i>Table 25: Ordering information scheme</i>.</p> |
| 15-Jul-2008 | 9 | <p>WLCSP package added (see <i>Figure 3: WLCSP connections (top view, marking side, with balls on the underside)</i> and <i>Section 10: Package mechanical data</i>).</p> |

Table 26. Document revision history (continued)

| Date | Revision | Changes |
|-------------|----------|--|
| 24-Jun-2010 | 10 | M95256-DR part number added. Updated Section 3.8: Operating supply voltage (VCC) Updated Section 4.3: Data protection and protocol control Updated Section 5.4: Write Status Register (WRSR) Added note in Section 5.6: Write to Memory Array (WRITE) Updated Table 7: Absolute maximum ratings Added Table 20: AC characteristics (M95256-DR, M95256-R device grade 6) Updated Table 20: AC characteristics (M95256-DR, M95256-R device grade 6) |
| 07-Sep-2010 | 11 | Updated Section 1: Description . Updated Section 5.7: Read Identification Page (available only in M95256-DR devices) . Updated Section 5.8: Write Identification Page . Updated Section 5.9: Read Lock Status (available only in M95256-DR devices) . |

Table 26. Document revision history (continued)

| Date | Revision | Changes |
|-------------|----------|--|
| 12-Nov-2010 | 12 | <p>Updated <i>Features</i>.</p> <p>Updated <i>Section 5.8: Write Identification Page</i>.</p> <p>Added <i>Figure 25: TSSOP8 – 8 lead thin shrink small outline, package outline</i>.</p> <p>Added <i>Table 23: UFDFPN8 (MLP8) – 8-lead ultra thin fine pitch dual flat package no lead 2 x 3 mm, package mechanical data</i>.</p> <p>Updated <i>Section 11: Part numbering</i>.</p> <p>Updated <i>Table 26: Available M95256x products (package, voltage range, temperature grade)</i>.</p> <p>Updated <i>Figure 25, Figure 26</i>.</p> |
| 22-Mar-2011 | 13 | <p>Deleted:</p> <ul style="list-style-type: none"> – SO8 (MW) picture under <i>Features</i> – SO8 (MW) mechanical dimensions <p>Updated:</p> <ul style="list-style-type: none"> – UFDFPN8 (MB) with UFDFPN8 (MB, MC) picture under <i>Features</i> – <i>Section 5.6.1: ECC (error correction code) and Write cycling</i> – <i>Section 7: Connecting to the SPI bus</i> – <i>Table 7: Absolute maximum ratings</i> <p>Process letter K substituted with only concerned products (M95256-D and M95256 in MLP8 package MC).</p> <ul style="list-style-type: none"> – Rephrased “test condition” text in: <ul style="list-style-type: none"> <i>Table 13: DC characteristics (M95256, device grade 3)</i> <i>Table 14: DC characteristics (M95256-W, device grade 6)</i> <i>Table 15: DC characteristics (M95256-W, device grade 3)</i> <i>Table 16: DC characteristics (M95256-R, M95256-DR, device grade 6)</i> <i>Table 17: AC characteristics (M95256, device grade 3)</i> <i>Table 18: AC characteristics, M95256-W, device grade 6</i> <i>Table 19: AC characteristics (M95256-W, device grade 3)</i> <i>Table 20: AC characteristics (M95256-DR, M95256-R device grade 6)</i> <p>Added:</p> <ul style="list-style-type: none"> – Caution under <i>Figure 3: WLCSP connections (top view, marking side, with balls on the underside)</i> – MC = UFDFPN8 package in <i>Section 11: Part numbering</i> |

Please Read Carefully:

Information in this document is provided solely in connection with ST products. STMicroelectronics NV and its subsidiaries ("ST") reserve the right to make changes, corrections, modifications or improvements, to this document, and the products and services described herein at any time, without notice.

All ST products are sold pursuant to ST's terms and conditions of sale.

Purchasers are solely responsible for the choice, selection and use of the ST products and services described herein, and ST assumes no liability whatsoever relating to the choice, selection or use of the ST products and services described herein.

No license, express or implied, by estoppel or otherwise, to any intellectual property rights is granted under this document. If any part of this document refers to any third party products or services it shall not be deemed a license grant by ST for the use of such third party products or services, or any intellectual property contained therein or considered as a warranty covering the use in any manner whatsoever of such third party products or services or any intellectual property contained therein.

UNLESS OTHERWISE SET FORTH IN ST'S TERMS AND CONDITIONS OF SALE ST DISCLAIMS ANY EXPRESS OR IMPLIED WARRANTY WITH RESPECT TO THE USE AND/OR SALE OF ST PRODUCTS INCLUDING WITHOUT LIMITATION IMPLIED WARRANTIES OF MERCHANTABILITY, FITNESS FOR A PARTICULAR PURPOSE (AND THEIR EQUIVALENTS UNDER THE LAWS OF ANY JURISDICTION), OR INFRINGEMENT OF ANY PATENT, COPYRIGHT OR OTHER INTELLECTUAL PROPERTY RIGHT.

UNLESS EXPRESSLY APPROVED IN WRITING BY AN AUTHORIZED ST REPRESENTATIVE, ST PRODUCTS ARE NOT RECOMMENDED, AUTHORIZED OR WARRANTED FOR USE IN MILITARY, AIR CRAFT, SPACE, LIFE SAVING, OR LIFE SUSTAINING APPLICATIONS, NOR IN PRODUCTS OR SYSTEMS WHERE FAILURE OR MALFUNCTION MAY RESULT IN PERSONAL INJURY, DEATH, OR SEVERE PROPERTY OR ENVIRONMENTAL DAMAGE. ST PRODUCTS WHICH ARE NOT SPECIFIED AS "AUTOMOTIVE GRADE" MAY ONLY BE USED IN AUTOMOTIVE APPLICATIONS AT USER'S OWN RISK.

Resale of ST products with provisions different from the statements and/or technical features set forth in this document shall immediately void any warranty granted by ST for the ST product or service described herein and shall not create or extend in any manner whatsoever, any liability of ST.

ST and the ST logo are trademarks or registered trademarks of ST in various countries.

Information in this document supersedes and replaces all information previously supplied.

The ST logo is a registered trademark of STMicroelectronics. All other names are the property of their respective owners.

© 2011 STMicroelectronics - All rights reserved

STMicroelectronics group of companies

Australia - Belgium - Brazil - Canada - China - Czech Republic - Finland - France - Germany - Hong Kong - India - Israel - Italy - Japan - Malaysia - Malta - Morocco - Philippines - Singapore - Spain - Sweden - Switzerland - United Kingdom - United States of America

www.st.com

