



M95640 M95640-W M95640-R M95640-DR

64 Kbit serial SPI bus EEPROMs
with high-speed clock

Features

- Compatible with the Serial Peripheral Interface (SPI) bus
- Memory array
 - 64 Kb (8 Kbytes) of EEPROM
 - Page size: 32 bytes
- Additional Write lockable Page (Identification page)
- Write (self timed cycle)
 - Byte Write within 5 ms
 - Page Write within 5 ms
- Write Protect: quarter, half or whole memory array
- High speed clock frequency (20 MHz)
- Single supply voltage: 1.8 V to 5.5 V
- More than 1 million Write cycles
- More than 40-year data retention
- Enhanced ESD Protection
- Packages
 - ECOPACK2® (RoHS-compliant and Halogen-free)



SO8 (MN)
150 mil width



TSSOP8 (DW)
169 mil width



UFDFPN8 (MB or MC)
2 x 3 mm

Contents

1	Description	6
2	Signal description	8
2.1	Serial Data output (Q)	8
2.2	Serial Data input (D)	8
2.3	Serial Clock (C)	8
2.4	Chip Select (\overline{S})	8
2.5	Hold (\overline{HOLD})	8
2.6	Write Protect (\overline{W})	9
2.7	V_{SS} ground	9
2.8	V_{CC} supply voltage	9
3	Connecting to the SPI bus	10
3.1	SPI modes	11
4	Operating features	12
4.1	Supply voltage (V_{CC})	12
4.1.1	Operating supply voltage V_{CC}	12
4.1.2	Device reset	12
4.1.3	Power-up conditions	12
4.1.4	Power-down	13
4.2	Active Power and Standby Power modes	13
4.2.1	Hold condition	13
4.3	Status Register	14
4.4	Data protection and protocol control	14
5	Memory organization	15
6	Instructions	16
6.1	Write Enable (WREN)	16
6.2	Write Disable (WRDI)	18
6.3	Read Status Register (RDSR)	19
6.3.1	WIP bit	19

6.3.2	WEL bit	19
6.3.3	BP1, BP0 bits	19
6.3.4	SRWD bit	19
6.4	Write Status Register (WRSR)	20
6.5	Read from Memory Array (READ)	22
6.6	Write to Memory Array (WRITE)	23
6.7	Read Identification Page	24
6.8	Write Identification Page	26
6.9	Read Lock Status	26
6.10	Lock ID	27
7	Power-up and delivery state	28
7.1	Power-up state	28
7.2	Initial delivery state	28
8	Maximum rating	29
9	DC and AC parameters	30
10	Package mechanical data	40
11	Part numbering	43
12	Revision history	44

List of tables

Table 1.	Signal names	7
Table 2.	Write-protected block size	14
Table 3.	M95640-x Instruction set	16
Table 4.	M95640-DR instruction set	16
Table 5.	Status Register format	19
Table 6.	Protection modes	21
Table 7.	Address range bits	21
Table 8.	Absolute maximum ratings	29
Table 9.	Operating conditions (M95640 device grade 3)	30
Table 10.	Operating conditions (M95640-W)	30
Table 11.	Operating conditions (M95640-R device grade 6)	30
Table 12.	AC measurement conditions.	30
Table 13.	Capacitance	31
Table 14.	DC characteristics (M95640, device grade 3)	31
Table 15.	DC characteristics (M95640-W, device grade 6)	32
Table 16.	DC characteristics (M95640-W, device grade 3)	33
Table 17.	DC characteristics (M95640-R, M95640-DR, device grade 6)	33
Table 18.	AC characteristics (M95640, device grade 3)	34
Table 19.	AC characteristics (M95640-W products, device grade 6)	35
Table 20.	AC characteristics (M95640-W products, device grade 3)	36
Table 21.	AC characteristics (M95640-R, M95640-DR devices, grade 6)	37
Table 22.	SO8N – 8-lead plastic small outline, 150 mils body width, package mechanical data	40
Table 23.	TSSOP8 – 8-lead thin shrink small outline, package mechanical data.	41
Table 24.	UFDFPN8 (MLP8) 8-lead ultra thin fine pitch dual flat package no lead 2 x 3 mm, data	42
Table 25.	Ordering information scheme	43
Table 26.	Document revision history	44

List of figures

Figure 1.	Logic diagram	6
Figure 2.	8-pin package connections	6
Figure 3.	Bus master and memory devices on the SPI bus	10
Figure 4.	SPI modes supported	11
Figure 5.	Hold condition activation	13
Figure 6.	Block diagram	15
Figure 7.	Write Enable (WREN) sequence	17
Figure 8.	Write Disable (WRDI) sequence	18
Figure 9.	Read Status Register (RDSR) sequence	20
Figure 10.	Write Status Register (WRSR) sequence	22
Figure 11.	Read from Memory Array (READ) sequence	22
Figure 12.	Byte Write (WRITE) sequence	23
Figure 13.	Page Write (WRITE) sequence	24
Figure 14.	Read Identification Page sequence	25
Figure 15.	Write Identification Page sequence	26
Figure 16.	Read Lock Status sequence	27
Figure 17.	Lock ID sequence	27
Figure 18.	AC measurement I/O waveform	30
Figure 19.	Serial input timing	38
Figure 20.	Hold timing	38
Figure 21.	Serial output timing	39
Figure 22.	SO8N – 8-lead plastic small outline, 150 mils body width, package outline	40
Figure 23.	TSSOP8 – 8-lead thin shrink small outline, package outline	41
Figure 24.	UFDFPN8 (MLP8) - 8-lead ultra thin fine pitch dual flat no lead, package outline	42

1 Description

The M95640, M95640-W and M95640-R are electrically erasable programmable memory (EEPROM) devices. They are accessed by a high-speed SPI-compatible bus. The devices are 64 Kbit devices organized as 8192×8 bits.

The M95640-D also offers an additional page, named the Identification Page (32 bytes) which can be written and (later) permanently locked in Read-only mode. This Identification Page offers flexibility in the application board production line, as it can be used to store unique identification parameters and/or parameters specific to the production line.

The device is accessed by a simple serial interface that is SPI-compatible. The bus signals are C, D and Q, as shown in [Table 1](#) and [Figure 1](#).

The device is selected when Chip Select (\bar{S}) is taken low. Communications with the device can be interrupted using Hold ($\overline{\text{HOLD}}$).

Figure 1. Logic diagram

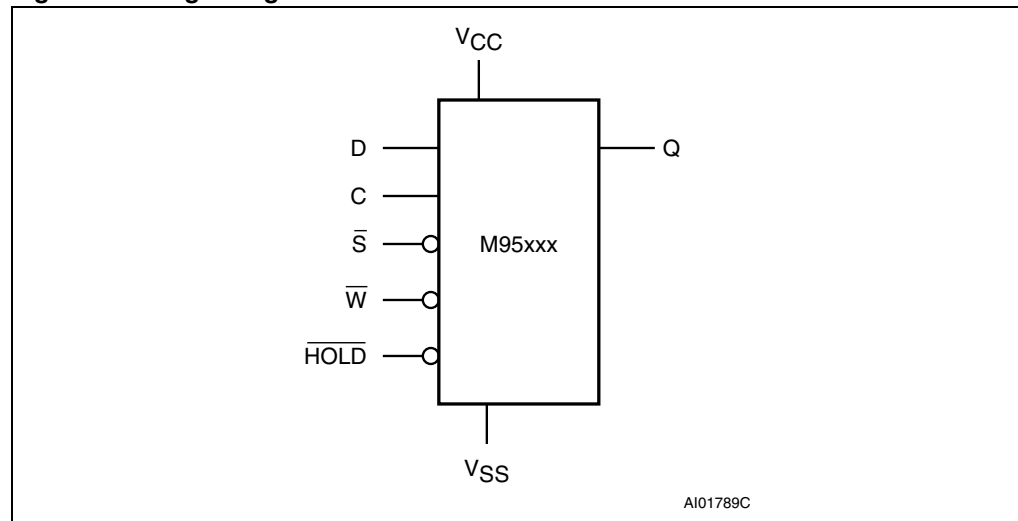
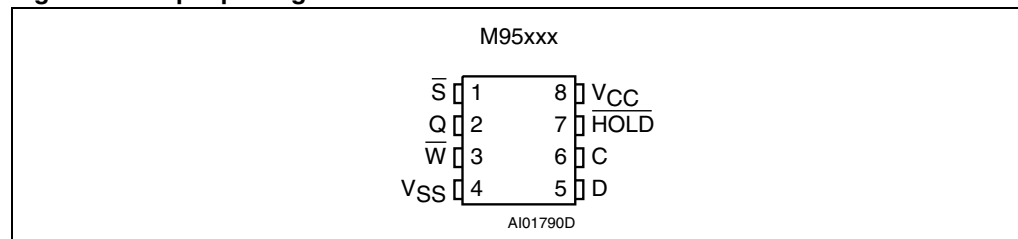

Figure 2. 8-pin package connections



1. See [Package mechanical data](#) section for package dimensions and how to identify pin-1.

Table 1. Signal names

Signal name	Description
C	Serial Clock
D	Serial data input
Q	Serial data output
\bar{S}	Chip Select
\bar{W}	Write Protect
$\overline{\text{HOLD}}$	Hold
V _{CC}	Supply voltage
V _{SS}	Ground

2 Signal description

During all operations, V_{CC} must be held stable and within the specified valid range: $V_{CC}(\min)$ to $V_{CC}(\max)$.

All of the input and output signals must be held high or low (according to voltages of V_{IH} , V_{OH} , V_{IL} or V_{OL} , as specified in [Table 14](#)). These signals are described next.

2.1 Serial Data output (Q)

This output signal is used to transfer data serially out of the device. Data is shifted out on the falling edge of Serial Clock (C).

2.2 Serial Data input (D)

This input signal is used to transfer data serially into the device. It receives instructions, addresses, and the data to be written. Values are latched on the rising edge of Serial Clock (C).

2.3 Serial Clock (C)

This input signal provides the timing of the serial interface. Instructions, addresses, or data present at Serial Data Input (D) are latched on the rising edge of Serial Clock (C). Data on Serial Data Output (Q) changes after the falling edge of Serial Clock (C).

2.4 Chip Select (\overline{S})

When this input signal is high, the device is deselected and Serial Data output (Q) is at high impedance. Unless an internal Write cycle is in progress, the device will be in the Standby Power mode. Driving Chip Select (\overline{S}) low selects the device, placing it in the Active Power mode.

After Power-up, a falling edge on Chip Select (\overline{S}) is required prior to the start of any instruction.

2.5 Hold (\overline{HOLD})

The Hold (\overline{HOLD}) signal is used to pause any serial communications with the device without deselecting the device.

During the Hold condition, the Serial Data output (Q) is high impedance, and Serial Data input (D) and Serial Clock (C) are Don't Care.

To start the Hold condition, the device must be selected, with Chip Select (\overline{S}) driven low.

2.6 Write Protect (\overline{W})

The main purpose of this input signal is to freeze the size of the area of memory that is protected against Write instructions (as specified by the values in the BP1 and BP0 bits of the Status Register).

This pin must be driven either high or low, and must be stable during all write operations.

2.7 V_{SS} ground

V_{SS} is the reference for the V_{CC} supply voltage.

2.8 V_{CC} supply voltage

Refer to [Section 4.1: Supply voltage \(VCC\) on page 12](#).

3 Connecting to the SPI bus

These devices are fully compatible with the SPI protocol.

All instructions, addresses and input data bytes are shifted in to the device, most significant bit first. The Serial Data input (D) is sampled on the first rising edge of the Serial Clock (C) after Chip Select (\bar{S}) goes low.

All output data bytes are shifted out of the device, most significant bit first. The Serial Data output (Q) is latched on the first falling edge of the Serial Clock (C) after the instruction (such as the Read from Memory Array and Read Status Register instructions) have been clocked into the device.

Figure 3 shows three devices, connected to an MCU, on a SPI bus. Only one device is selected at a time, so only one device drives the Serial Data output (Q) line at a time, all the others being high impedance.

Figure 3. Bus master and memory devices on the SPI bus

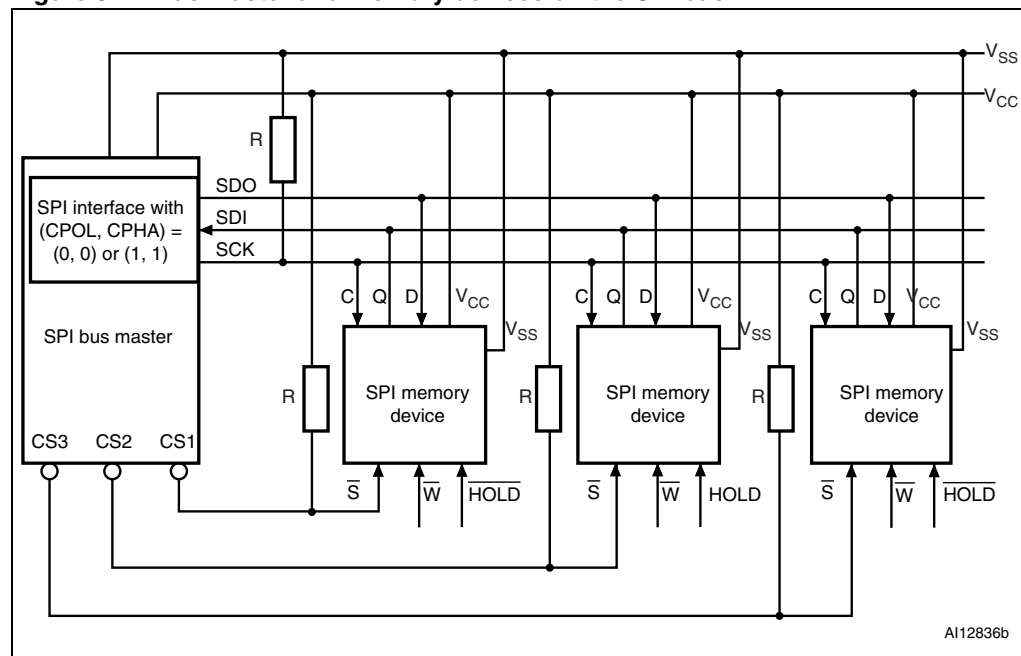

1. The Write Protect (\bar{W}) and Hold ($\overline{\text{HOLD}}$) signals should be driven, high or low as appropriate.

A pull-up resistor connected on each \bar{S} input (represented in *Figure 3*) ensures that each device is not selected if the bus master leaves the \bar{S} line in the high impedance state.

In applications where the bus master might enter a state where all inputs/outputs SPI bus would be in high impedance at the same time (for example, if the bus master is reset during the transmission of an instruction), the clock line (C) must be connected to an external pull-down resistor so that, if all inputs/outputs become high impedance, the C line is pulled low (while the \bar{S} line is pulled high): this will ensure that \bar{S} and C do not become high at the same time, and so, that the t_{SHCH} requirement is met. The typical value of R is 100 k Ω

3.1 SPI modes

These devices can be driven by a microcontroller with its SPI peripheral running in either of the two following modes:

- CPOL=0, CPHA=0
- CPOL=1, CPHA=1

For these two modes, input data is latched in on the rising edge of Serial Clock (C), and output data is available from the falling edge of Serial Clock (C).

The difference between the two modes, as shown in [Figure 4](#), is the clock polarity when the bus master is in Stand-by mode and not transferring data:

- C remains at 0 for (CPOL=0, CPHA=0)
- C remains at 1 for (CPOL=1, CPHA=1)

Figure 4. SPI modes supported

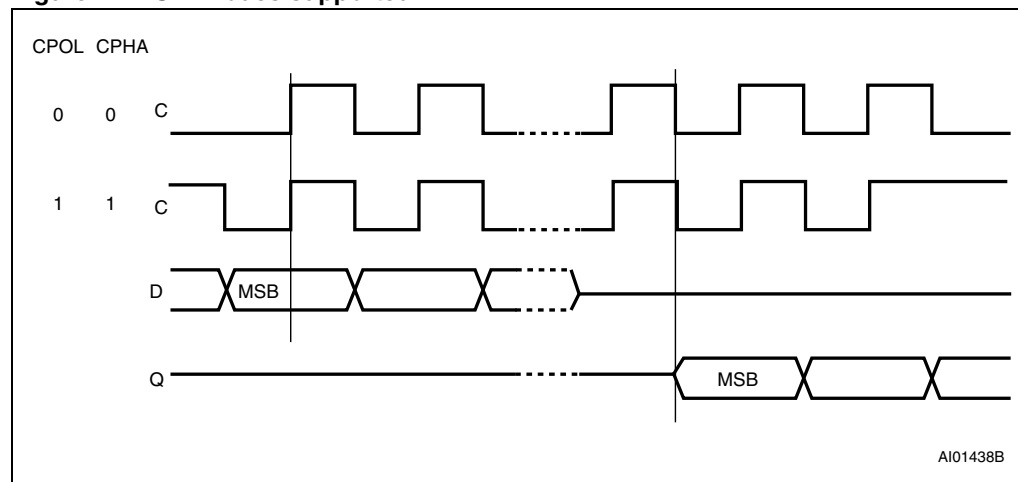

4 Operating features

4.1 Supply voltage (V_{CC})

4.1.1 Operating supply voltage V_{CC}

Prior to selecting the memory and issuing instructions to it, a valid and stable V_{CC} voltage within the specified [$V_{CC}(\min)$, $V_{CC}(\max)$] range must be applied (see [Table 9](#) and [Table 10](#)). This voltage must remain stable and valid until the end of the transmission of the instruction and, for a Write instruction, until the completion of the internal write cycle (t_W). In order to secure a stable DC supply voltage, it is recommended to decouple the V_{CC} line with a suitable capacitor (usually of the order of 10 nF to 100 nF) close to the V_{CC}/V_{SS} package pins.

4.1.2 Device reset

In order to prevent inadvertent write operations during power-up, a power-on-reset (POR) circuit is included. At power-up, the device does not respond to any instruction until V_{CC} reaches the internal threshold voltage (this threshold is defined in DC characteristics tables [14](#), [15](#) and [16](#) as V_{RES}).

When V_{CC} passes over the POR threshold, the device is reset and in the following state:

- in the Standby Power mode
- deselected (note that, to be executed, an instruction must be preceded by a falling edge on Chip Select (\bar{S}))
- Status register values:
 - the Write Enable Latch (WEL) bit is reset to 0
 - the Write In Progress (WIP) bit is reset to 0
 - the SRWD, BP1 and BP0 bits remain unchanged (non-volatile bits).

When V_{CC} passes over the POR threshold, the device is reset and enters the Standby Power mode. The device must not be accessed until V_{CC} reaches a valid and stable V_{CC} voltage within the specified [$V_{CC}(\min)$, $V_{CC}(\max)$] range defined in [Table 9](#) and [Table 10](#).

4.1.3 Power-up conditions

When the power supply is turned on, V_{CC} continuously rises from V_{SS} to V_{CC} . During this time, the Chip Select (\bar{S}) line is not allowed to float but should follow the V_{CC} voltage. It is therefore recommended to connect the \bar{S} line to V_{CC} via a suitable pull-up resistor (see [Figure 3](#)).

In addition, the Chip Select (\bar{S}) input offers a built-in safety feature, as the \bar{S} input is edge-sensitive as well as level-sensitive: after power-up, the device does not become selected until a falling edge has first been detected on Chip Select (\bar{S}). This ensures that Chip Select (\bar{S}) must have been high, prior to going low to start the first operation.

The V_{CC} voltage has to rise continuously from 0 V up to the minimum V_{CC} operating voltage defined in [Table 9](#) and [Table 10](#) and the rise time must not vary faster than 1 V/ μ s.

4.1.4 Power-down

During power-down (continuous decrease in the V_{CC} supply voltage below the minimum V_{CC} operating voltage defined in [Table 9](#) and [Table 10](#)), the device must be:

- deselected (Chip Select \bar{S} should be allowed to follow the voltage applied on V_{CC})
- in Standby Power mode (there should not be any internal write cycle in progress).

4.2 Active Power and Standby Power modes

When Chip Select (\bar{S}) is low, the device is selected, and in the Active Power mode. The device consumes I_{CC} , as specified in [Table 14](#) to [Table 18](#).

When Chip Select (\bar{S}) is high, the device is deselected. If a Write cycle is not currently in progress, the device then goes in to the Standby Power mode, and the device consumption drops to I_{CC1} .

4.2.1 Hold condition

The Hold (\overline{HOLD}) signal is used to pause any serial communications with the device without resetting the clocking sequence.

During the Hold condition, the Serial Data output (Q) is high impedance, and Serial Data input (D) and Serial Clock (C) are Don't Care.

To enter the Hold condition, the device must be selected, with Chip Select (\bar{S}) low.

Normally, the device is kept selected, for the whole duration of the Hold condition. Deselecting the device while it is in the Hold condition, has the effect of resetting the state of the device, and this mechanism can be used if it is required to reset any processes that had been in progress.

The Hold condition starts when the Hold (\overline{HOLD}) signal is driven low at the same time as Serial Clock (C) already being low (as shown in [Figure 5](#)).

The Hold condition ends when the Hold (\overline{HOLD}) signal is driven high at the same time as Serial Clock (C) already being low.

[Figure 5](#) also shows what happens if the rising and falling edges are not timed to coincide with Serial Clock (C) being low.

Figure 5. Hold condition activation

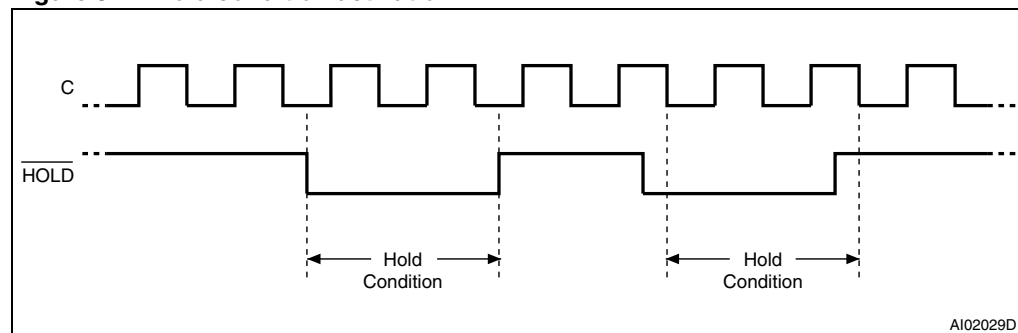

4.3 Status Register

Figure 6 shows the position of the Status Register in the control logic of the device. The Status Register contains a number of status and control bits that can be read or set (as appropriate) by specific instructions. See [Section 6.3: Read Status Register \(RDSR\)](#) for a detailed description of the Status Register bits.

4.4 Data protection and protocol control

Non-volatile memory devices can be used in environments that are particularly noisy, and within applications that could experience problems if memory bytes are corrupted. Consequently, the device features the following data protection mechanisms:

- Write and Write Status Register instructions are checked that they consist of a number of clock pulses that is a multiple of eight, before they are accepted for execution.
- All instructions that modify data must be preceded by a Write Enable (WREN) instruction to set the Write Enable Latch (WEL) bit. This bit is returned to its reset state by the following events:
 - Power-up
 - Write Disable (WRDI) instruction completion
 - Write Status Register (WRSR) instruction completion
 - Write (WRITE) instruction completion
- The Block Protect (BP1, BP0) bits in the Status Register allow part of the memory to be configured as read-only.
- The Write Protect (\overline{W}) signal is used to protect the Block Protect (BP1, BP0) bits of the Status Register.

For any instruction to be accepted, and executed, Chip Select (\overline{S}) must be driven high after the rising edge of Serial Clock (C) for the last bit of the instruction, and before the next rising edge of Serial Clock (C).

Two points need to be noted in the previous sentence:

- The 'last bit of the instruction' can be the eighth bit of the instruction code, or the eighth bit of a data byte, depending on the instruction (except for Read Status Register (RDSR) and Read (READ) instructions).
- The 'next rising edge of Serial Clock (C)' might (or might not) be the next bus transaction for some other device on the SPI bus.

Table 2. Write-protected block size

Status Register bits		Protected block	Array addresses protected
BP1	BP0		64 Kbit devices
0	0	none	none
0	1	Upper quarter	1800h - 1FFFh
1	0	Upper half	1000h - 1FFFh
1	1	Whole memory	0000h - 1FFFh

5 Memory organization

The memory is organized as shown in [Figure 6](#).

Figure 6. Block diagram

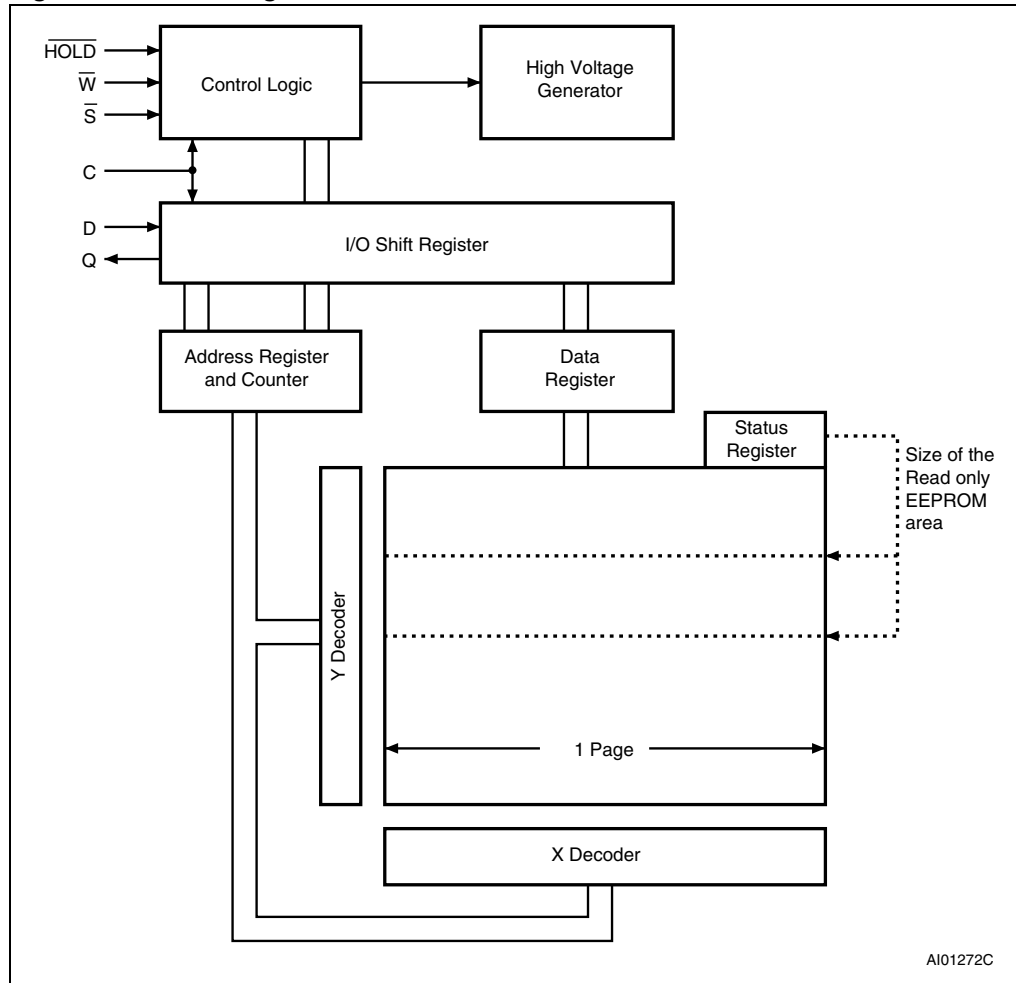

6 Instructions

Each instruction starts with a single-byte code, as summarized in [Table 3](#).

If an invalid instruction is sent (one not contained in [Table 3](#)), the device automatically deselects itself.

Table 3. M95640-x Instruction set

Instruction	Description	Instruction format
WREN	Write Enable	0000 0110
WRDI	Write Disable	0000 0100
RDSR	Read Status Register	0000 0101
WRSR	Write Status Register	0000 0001
READ	Read from Memory Array	0000 0011
WRITE	Write to Memory Array	0000 0010

Table 4. M95640-DR instruction set

Instruction	Description	Instruction format
WREN	Write Enable	0000 0110
WRDI	Write Disable	0000 0100
RDSR	Read Status Register	0000 0101
WRSR	Write Status Register	0000 0001
READ	Read from Memory Array	0000 0011
WRITE	Write to Memory Array	0000 0010
Read Identification Page	Reads the page dedicated to identification.	1000 0011
Write Identification Page	Writes the page dedicated to identification.	1000 0010
Read Lock Status	Reads the lock status of the Identification Page.	1000 0011
Lock ID	Locks the Identification page in read-only mode.	1000 0010

6.1 Write Enable (WREN)

The Write Enable Latch (WEL) bit must be set prior to each WRITE and WRSR instruction. The only way to do this is to send a Write Enable instruction to the device.

As shown in [Figure 7](#), to send this instruction to the device, Chip Select (\bar{S}) is driven low, and the bits of the instruction byte are shifted in, on Serial Data Input (D). The device then enters a wait state. It waits for the device to be deselected, by Chip Select (\bar{S}) being driven high.

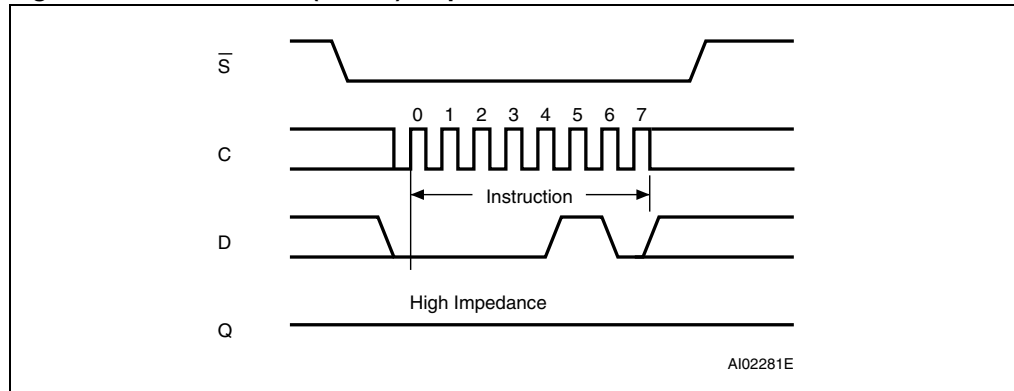
Figure 7. Write Enable (WREN) sequence

6.2 Write Disable (WRDI)

One way of resetting the Write Enable Latch (WEL) bit is to send a Write Disable instruction to the device.

As shown in [Figure 8](#), to send this instruction to the device, Chip Select (\overline{S}) is driven low, and the bits of the instruction byte are shifted in, on Serial Data Input (D).

The device then enters a wait state. It waits for the device to be deselected, by Chip Select (\overline{S}) being driven high.

The Write Enable Latch (WEL) bit, in fact, becomes reset by any of the following events:

- Power-up
- WRDI instruction execution
- WRSR instruction completion
- WRITE instruction completion.

Figure 8. Write Disable (WRDI) sequence

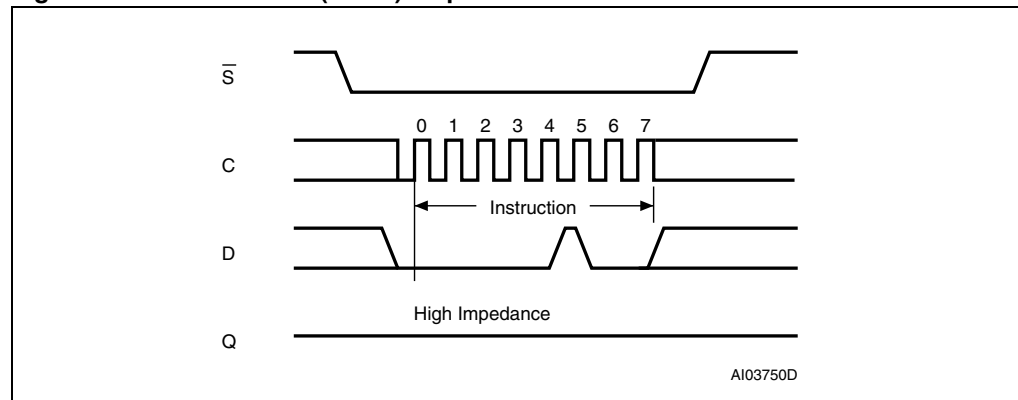

6.3 Read Status Register (RDSR)

The Read Status Register (RDSR) instruction allows the Status Register to be read. The Status Register may be read at any time, even while a Write or Write Status Register cycle is in progress. When one of these cycles is in progress, it is recommended to check the Write In Progress (WIP) bit before sending a new instruction to the device. It is also possible to read the Status Register continuously, as shown in [Figure 9](#).

The Status Register format is shown in [Table 5](#) and the status and control bits of the Status Register are as follows:

6.3.1 WIP bit

The Write In Progress (WIP) bit indicates whether the memory is busy with a Write or Write Status Register cycle. When set to 1, such a cycle is in progress, when reset to 0 no such cycle is in progress.

6.3.2 WEL bit

The Write Enable Latch (WEL) bit indicates the status of the internal Write Enable Latch. When set to 1 the internal Write Enable Latch is set, when set to 0 the internal Write Enable Latch is reset and no Write or Write Status Register instruction is accepted.

6.3.3 BP1, BP0 bits

The Block Protect (BP1, BP0) bits are non-volatile. They define the size of the area to be software protected against Write instructions. These bits are written with the Write Status Register (WRSR) instruction. When one or both of the Block Protect (BP1, BP0) bits is set to 1, the relevant memory area (as defined in [Table 5](#)) becomes protected against Write (WRITE) instructions. The Block Protect (BP1, BP0) bits can be written provided that the Hardware Protected mode has not been set.

6.3.4 SRWD bit

The Status Register Write Disable (SRWD) bit is operated in conjunction with the Write Protect (\overline{W}) signal. The Status Register Write Disable (SRWD) bit and Write Protect (\overline{W}) signal allow the device to be put in the Hardware Protected mode (when the Status Register Write Disable (SRWD) bit is set to 1, and Write Protect (\overline{W}) is driven low). In this mode, the non-volatile bits of the Status Register (SRWD, BP1, BP0) become read-only bits and the Write Status Register (WRSR) instruction is no longer accepted for execution.

Table 5. Status Register format

b7							b0
SRWD	0	0	0	BP1	BP0	WEL	WIP
Status Register Write Protect				Block Protect bits		Write Enable Latch bit	Write In Progress bit

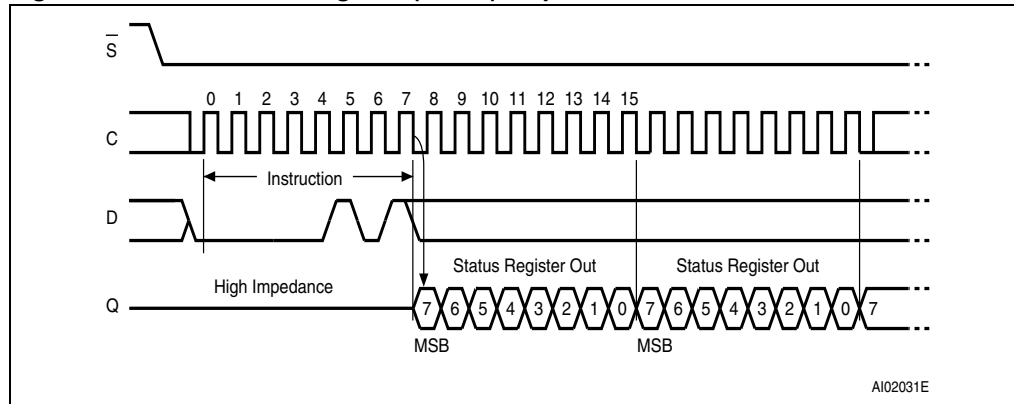
Figure 9. Read Status Register (RDSR) sequence

6.4 Write Status Register (WRSR)

The Write Status Register (WRSR) instruction allows new values to be written to the Status Register. Before it can be accepted, a Write Enable (WREN) instruction must previously have been executed.

The Write Status Register (WRSR) instruction is entered by driving Chip Select (\bar{S}) low, sending the instruction code followed by the data byte on Serial Data input (D), and driving the Chip Select (\bar{S}) signal high. Chip Select (\bar{S}) must be driven high after the rising edge of Serial Clock (C) that latches in the eighth bit of the data byte, and before the next rising edge of Serial Clock (C). Otherwise, the Write Status Register (WRSR) instruction is not properly executed.

Driving the Chip Select (\bar{S}) signal high at a byte boundary of the input data triggers the self-timed write cycle that takes t_W to complete (as specified in [Table 18](#), [Table 19](#), [Table 20](#) and [Table 21](#)). The instruction sequence is shown in [Figure 10](#).

While the Write Status Register cycle is in progress, the Status Register may still be read to check the value of the Write in progress (WIP) bit: the WIP bit is 1 during the self-timed write cycle t_W , and is 0 when the write cycle is complete. The WEL bit (Write enable latch) is also reset at the end of the write cycle t_W .

The Write Status Register (WRSR) instruction allows the user to change the values of the BP1, BP0 bits and the SRWD bit:

- The Block protect (BP1, BP0) bits define the size of the area that is to be treated as read only, as defined in [Table 2](#).
- The SRWD bit (Status register write disable bit), in accordance with the signal read on the Write protect pin (\bar{W}), allows the user to set or reset the write protection mode of the Status Register itself, as shown in [Table 6](#). When in the Write-protected mode, the Write Status Register (WRSR) instruction is not executed.

The contents of the SRWD and BP1, BP0 bits are updated after the completion of the WRSR instruction, including the t_W write cycle.

The Write Status Register (WRSR) instruction has no effect on the b6, b5, b4, b1 and b0 bits in the Status Register. Bits b6, b5, b4 are always read as 0.

Table 6. Protection modes

\bar{W} signal	SRWD bit	Mode	Write protection of the Status Register	Memory content	
				Protected area ⁽¹⁾	Unprotected area ⁽¹⁾
1	0	Software protected (SPM)	Status Register is Writable (if the WREN instruction has set the WEL bit) The values in the BP1 and BP0 bits can be changed	Write Protected	Ready to accept Write instructions
0	0				
1	1				
0	1	Hardware protected (HPM)	Status Register is Hardware write protected The values in the BP1 and BP0 bits cannot be changed	Write Protected	Ready to accept Write instructions

1. As defined by the values in the Block Protect (BP1, BP0) bits of the Status Register, as shown in [Table 2](#).

The protection features of the device are summarized in [Table 6](#).

When the Status Register Write Disable (SRWD) bit of the Status Register is 0 (its initial delivery state), it is possible to write to the Status Register provided that the Write Enable Latch (WEL) bit has previously been set by a Write Enable (WREN) instruction, regardless of whether Write Protect (\bar{W}) is driven high or low.

When the Status Register Write Disable (SRWD) bit of the Status Register is set to 1, two cases need to be considered, depending on the state of Write Protect (\bar{W}):

- If Write Protect (\bar{W}) is driven high, it is possible to write to the Status Register provided that the Write enable latch (WEL) bit has previously been set by a Write Enable (WREN) instruction.
- If Write Protect (\bar{W}) is driven low, it is *not* possible to write to the Status Register *even* if the Write Enable latch (WEL) bit has previously been set by a Write Enable (WREN) instruction. (Attempts to write to the Status Register are rejected, and are not accepted for execution). As a consequence, all the data bytes in the memory area that are software-protected (SPM) by the Block protect (BP1, BP0) bits in the Status Register, are also hardware-protected against data modification.

Regardless of the order of the two events, the Hardware-protected mode (HPM) can be entered:

- by setting the Status register write disable (SRWD) bit after driving Write Protect (\bar{W}) low
- or by driving Write Protect (\bar{W}) low after setting the Status register write disable (SRWD) bit.

The only way to exit the Hardware-protected mode (HPM) once entered is to pull Write Protect (\bar{W}) high.

If Write Protect (\bar{W}) is permanently tied high, the Hardware-protected mode (HPM) can never be activated, and only the Software-protected mode (SPM), using the Block protect (BP1, BP0) bits in the Status Register, can be used.

Table 7. Address range bits⁽¹⁾

Device	64 Kbit devices
Address bits	A12-A0

1. b15 to b13 are Don't Care.

Figure 10. Write Status Register (WRSR) sequence

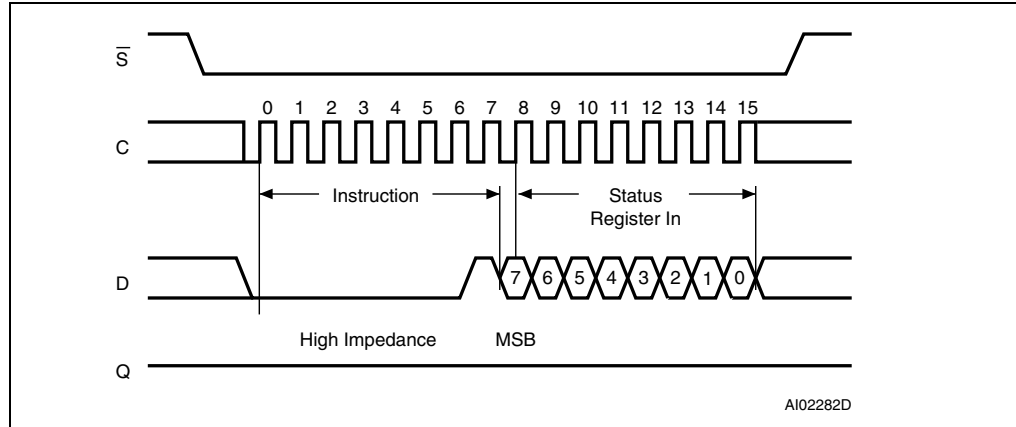

6.5 Read from Memory Array (READ)

As shown in [Figure 11](#), to send this instruction to the device, Chip Select (\bar{S}) is first driven low. The bits of the instruction byte and address bytes are then shifted in, on Serial Data Input (D). The address is loaded into an internal address register, and the byte of data at that address is shifted out, on Serial Data Output (Q).

If Chip Select (\bar{S}) continues to be driven low, the internal address register is automatically incremented, and the byte of data at the new address is shifted out.

When the highest address is reached, the address counter rolls over to zero, allowing the Read cycle to be continued indefinitely. The whole memory can, therefore, be read with a single READ instruction.

The Read cycle is terminated by driving Chip Select (\bar{S}) high. The rising edge of the Chip Select (\bar{S}) signal can occur at any time during the cycle.

The first byte addressed can be any byte within any page.

The instruction is not accepted, and is not executed, if a Write cycle is currently in progress.

Figure 11. Read from Memory Array (READ) sequence

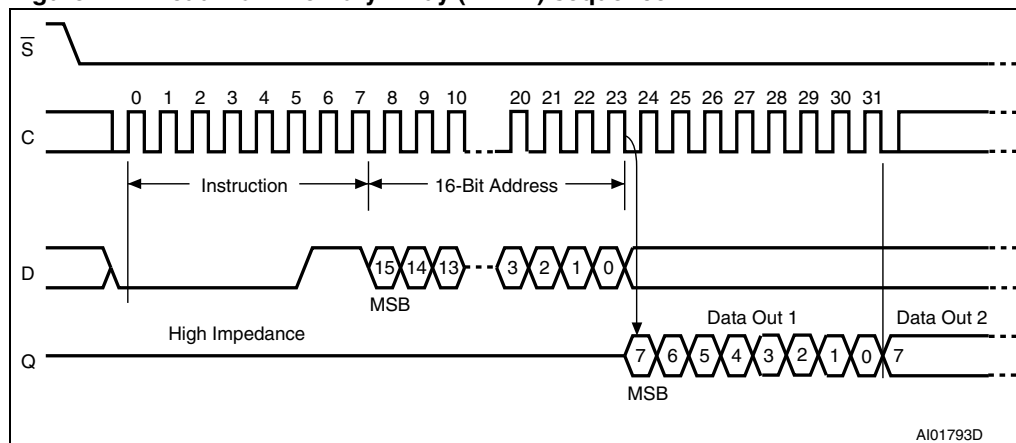

1. Depending on the memory size, as shown in [Table 7](#), the most significant address bits are Don't Care.

6.6 Write to Memory Array (WRITE)

As shown in [Figure 12](#), to send this instruction to the device, Chip Select (\overline{S}) is first driven low. The bits of the instruction byte, address byte, and at least one data byte are then shifted in, on Serial Data Input (D).

The instruction is terminated by driving Chip Select (\overline{S}) high at a byte boundary of the input data. In the case of [Figure 12](#), this occurs after the eighth bit of the data byte has been latched in, indicating that the instruction is being used to write a single byte. The self-timed Write cycle starts from the rising edge of Chip Select (\overline{S}), and continues for a period t_{WC} (as specified in [Table 19](#) to [Table 21](#)), at the end of which the Write in Progress (WIP) bit is reset to 0.

If, though, Chip Select (\overline{S}) continues to be driven low, as shown in [Figure 13](#), the next byte of input data is shifted in, so that more than a single byte, starting from the given address towards the end of the same page, can be written in a single internal Write cycle.

Each time a new data byte is shifted in, the least significant bits of the internal address counter are incremented. If the number of data bytes sent to the device exceeds the page boundary, the internal address counter rolls over to the beginning of the page, and the previous data there are overwritten with the incoming data. (The page size of these devices is 32 bytes).

The instruction is not accepted, and is not executed, under the following conditions:

- if the Write Enable Latch (WEL) bit has not been set to 1 (by executing a Write Enable instruction just before)
- if a write cycle is already in progress
- if the device has not been deselected, by Chip Select (\overline{S}) being driven high, at a byte boundary (after the eighth bit, b0, of the last data byte that has been latched in)
- if the addressed page is in the region protected by the Block Protect (BP1 and BP0) bits.

Note: The self-timed write cycle t_W is internally executed as a sequence of two consecutive events: [Erase addressed byte(s)], followed by [Program addressed byte(s)]. An erased bit is read as "0" and a programmed bit is read as "1".

Figure 12. Byte Write (WRITE) sequence

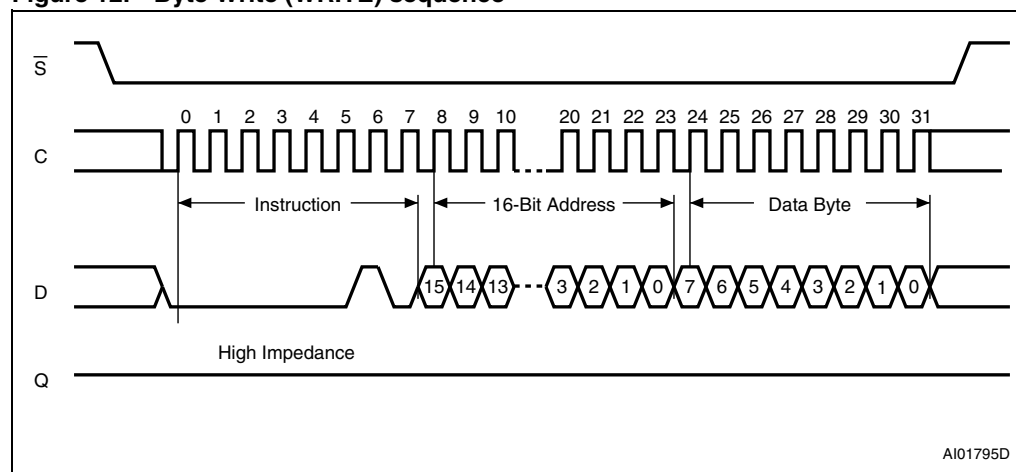

1. Depending on the memory size, as shown in [Table 7](#), the most significant address bits are Don't Care.

Figure 13. Page Write (WRITE) sequence

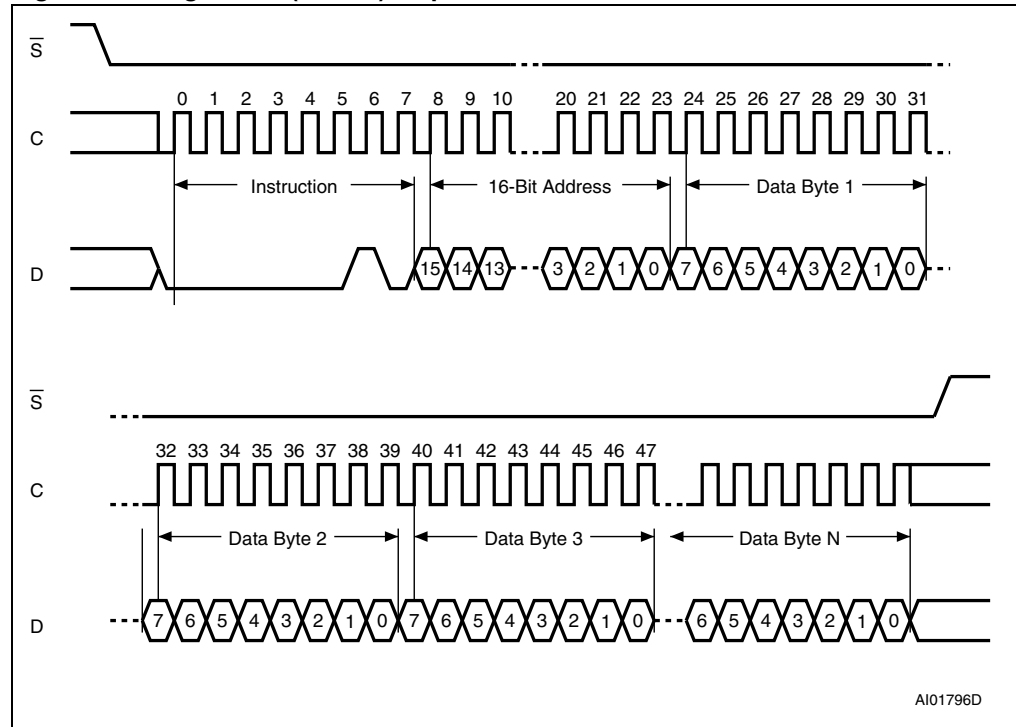

1. Depending on the memory size, as shown in [Table 7](#), the most significant address bits are Don't Care.

ECC (error correction code) and Write cycling

The M95640-x and M95640-Dx devices identified with the process letter K offer an ECC (error correction code) logic which compares each 4-byte word with its associated 6 EEPROM bits of ECC. As a result, if a single bit out of 4 bytes of data happens to be erroneous during a Read operation, the ECC detects it and replaces it with the correct value. The read reliability is therefore much improved by the use of this feature.

Note however that even if a single byte has to be written, 4 bytes are internally modified (plus the ECC bits), that is, the addressed byte is cycled together with the three other bytes making up the word. It is therefore recommended to write data by word (4 Bytes) at address $4 \cdot N$ (where N is an integer) in order to benefit from the larger amount of Write cycles.

The M95640-x and M95640-Dx devices are qualified at 1 million (1 000 000) Write cycles, using a cycling routine that writes to the device in multiples of 4-byte words.

6.7 Read Identification Page

The Identification Page (32 bytes) is an additional page which can be written and (later) permanently locked in Read-only mode.

Reading this page is achieved with the Read Identification Page instruction (see [Table 4](#)).

The Chip Select signal (S) is first driven low, the bits of the instruction byte and address bytes are then shifted in, on Serial Data input (D). Address bit A10 must be 0, address bits [A15:A11] and [A9:A5] are Don't Care, and the data byte pointed to by [A4:A0] is shifted out on Serial Data output (Q).

If Chip Select (\overline{S}) continues to be driven low, the internal address register is automatically incremented and the byte of data at the new address is shifted out. The number of bytes to read in the ID page must not exceed the page boundary (e.g.: when reading the ID page from location 10d, the number of bytes should be less than or equal to 22d, as the ID page boundary is 32 bytes).

The read cycle is terminated by driving Chip Select (\overline{S}) high. The rising edge of the Chip Select (\overline{S}) signal can occur at any time during the cycle. The first byte addressed can be any byte within any page.

The instruction is not accepted, and is not executed, if a write cycle is currently in progress.

Figure 14. Read Identification Page sequence

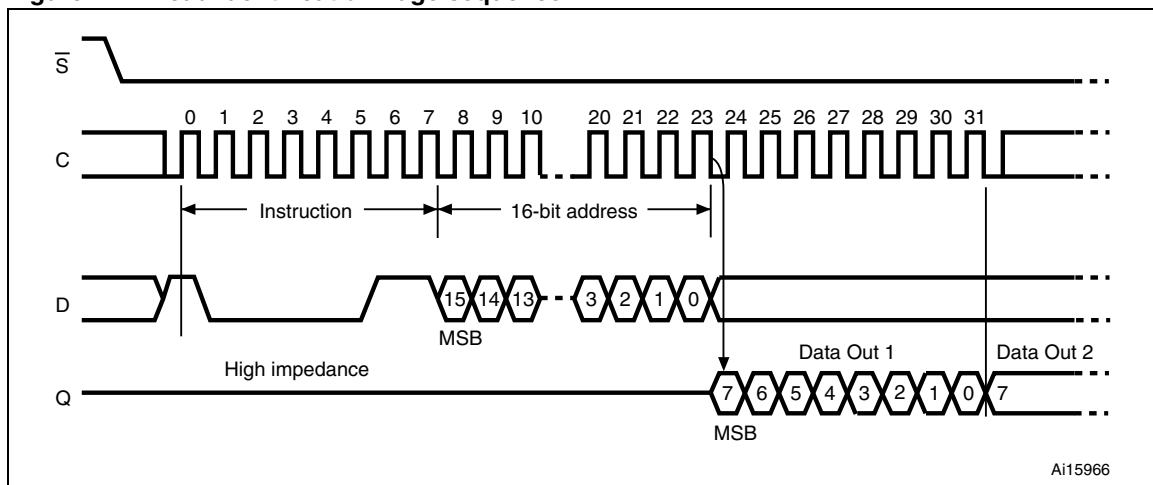

6.8 Write Identification Page

The Identification Page (32 bytes) is an additional page which can be written and (later) permanently locked in Read-only mode. Writing this page is achieved with the Write Identification Page instruction (see [Table 4](#)), the Chip Select signal (S) is first driven low. The bits of the instruction byte, address byte, and at least one data byte are then shifted in on Serial Data input (D). Address bit A10 must be 0, address bits [A15:A11] and [A9:A5] are Don't Care, the [A4:A0] address bits define the byte address inside the identification page.

Figure 15. Write Identification Page sequence

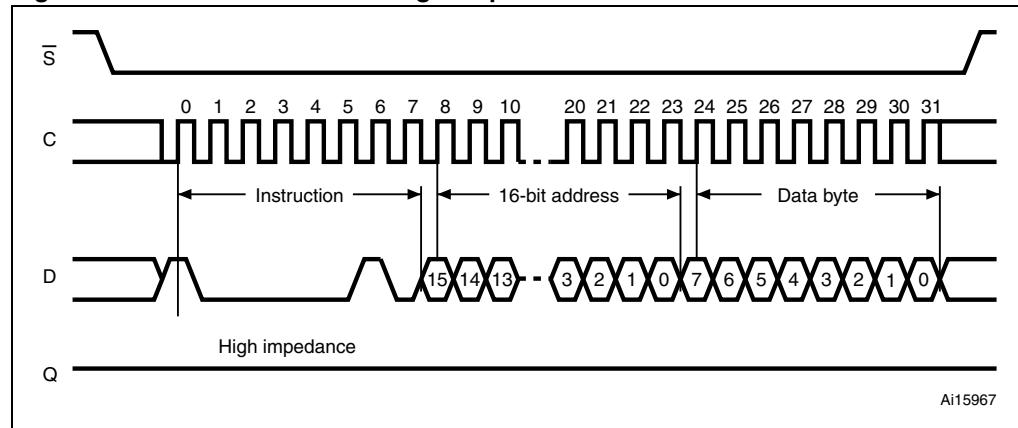

6.9 Read Lock Status

The Read Lock Status instruction is used to read the lock status. To send this instruction to the device, Chip Select (S) first has to be driven low. The bits of the instruction byte and address bytes are then shifted in on Serial Data input (D). Address bit A10 must be 1, all other address bits are Don't Care. The Lock bit is the LSB (least significant bit) of the byte read on Serial Data output (Q). It is at '1' when the lock is active and at '0' when the lock is not active. If Chip Select (S) continues to be driven low, the same data byte is shifted out.

The read cycle is terminated by driving Chip Select (S) high. The instruction sequence is shown in [Figure 16](#).

Figure 16. Read Lock Status sequence

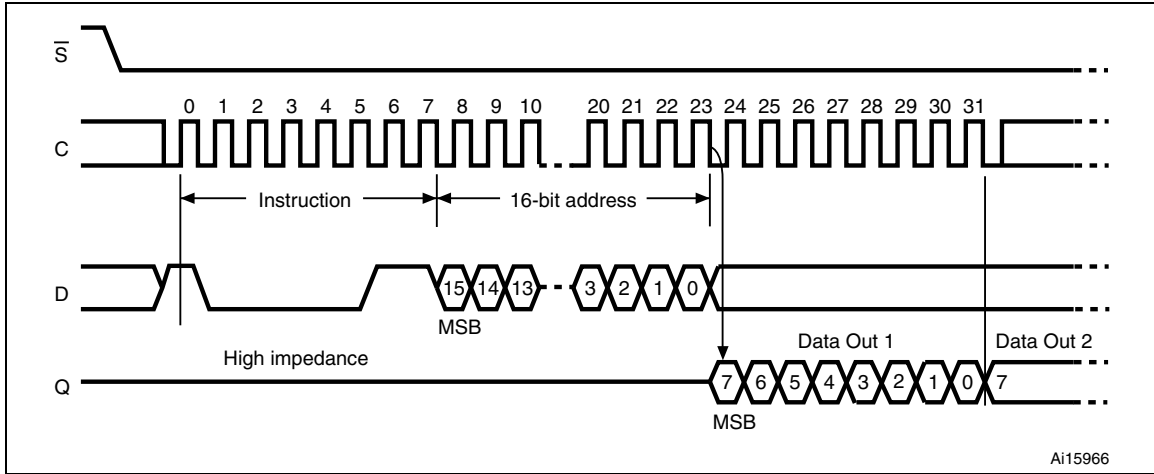

6.10 Lock ID

The Lock ID instruction permanently locks the Identification Page in read-only mode. Before this instruction can be accepted, a Write Enable (WREN) instruction must have been executed. The Lock ID instruction is issued by driving Chip Select (S) low, sending the instruction code, the address and a data byte on Serial Data input (D), and driving Chip Select (S) high. In the address sent, A10 must be equal to 1, all other address bits are Don't Care. The data byte sent must be equal to the binary value xxxx xx1x, where x = Don't Care.

Chip Select (S) must be driven high after the rising edge of Serial Clock (C) that latches in the eighth bit of the data byte, and before the next rising edge of Serial Clock (C). Otherwise, the Lock ID instruction is not executed.

Driving Chip Select (S) high at a byte boundary of the input data triggers the self-timed write cycle which duration is t_W (specified in Table 18, Table 19, Table 20 and Table 21). The instruction sequence is shown in Figure 17.

Figure 17. Lock ID sequence

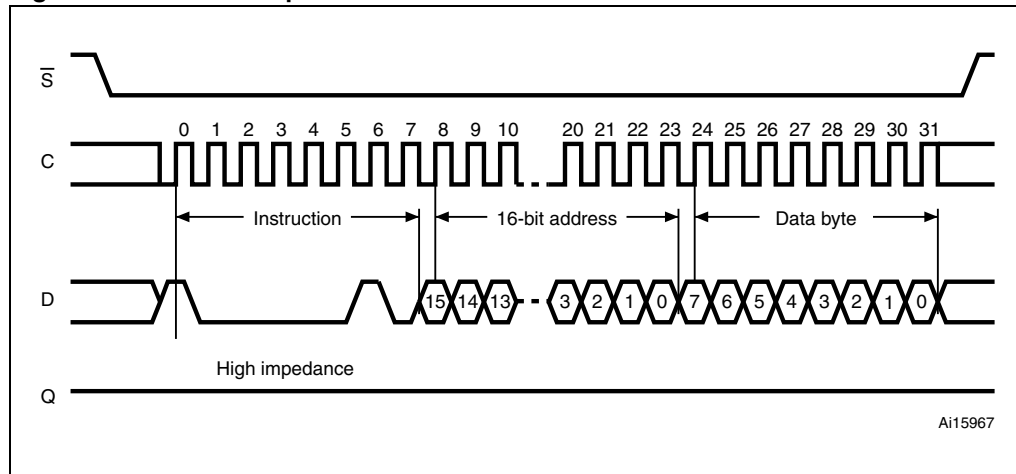

7 Power-up and delivery state

7.1 Power-up state

After Power-up, the device is in the following state:

- Standby Power mode
- deselected (after power-up, a falling edge is required on Chip Select (\bar{S}) before any instructions can be started).
- not in the Hold condition
- the Write Enable Latch (WEL) is reset to 0
- Write In Progress (WIP) is reset to 0

The SRWD, BP1 and BP0 bits of the Status Register are unchanged from the previous power-down (they are non-volatile bits).

7.2 Initial delivery state

The device is delivered with the memory array set to all 1s (each byte = FFh). The Status register write disable (SRWD) and Block protect (BP1 and BP0) bits are initialized to 0.

8 Maximum rating

Stressing the device outside the ratings listed in [Table 8](#) may cause permanent damage to the device. These are stress ratings only, and operation of the device at these, or any other conditions outside those indicated in the operating sections of this specification, is not implied. Exposure to absolute maximum rating conditions for extended periods may affect device reliability. Refer also to the STMicroelectronics SURE Program and other relevant quality documents.

Table 8. Absolute maximum ratings

Symbol	Parameter	Min.	Max.	Unit
T _{STG}	Storage temperature	-65	150	°C
	Ambient operating temperature	-40	130	°C
T _{LEAD}	Lead temperature during soldering	See note ⁽¹⁾		°C
V _O	Output voltage	-0.50	V _{CC} +0.6	V
V _I	Input voltage	-0.50	6.5	V
I _{OL}	DC output current (Q = 0)		5	mA
I _{OH}	DC output current (Q = 1)		-5	mA
V _{CC}	Supply voltage	-0.50	6.5	V
V _{ESD}	Electrostatic discharge voltage (human body model) ⁽²⁾		4000	V

1. Compliant with JEDEC Std J-STD-020 (for small body, Sn-Pb or Pb assembly), the ST ECOPACK[®] 7191395 specification, and the European directive on Restrictions on Hazardous Substances (RoHS) 2002/95/EU
2. AEC-Q100-002 (compliant with JEDEC Std JESD22-A114, C1 = 100 pF, R1 = 1500 Ω, R2 = 500 Ω)

9 DC and AC parameters

This section summarizes the operating and measurement conditions, and the DC and AC characteristics of the device. The parameters in the DC and AC characteristic tables that follow are derived from tests performed under the measurement conditions summarized in the relevant tables. Designers should check that the operating conditions in their circuit match the measurement conditions when relying on the quoted parameters.

Table 9. Operating conditions (M95640 device grade 3)

Symbol	Parameter	Min.	Max.	Unit
V_{CC}	Supply voltage	4.5	5.5	V
T_A	Ambient operating temperature (device grade 3)	-40	125	°C

Table 10. Operating conditions (M95640-W)

Symbol	Parameter	Min.	Max.	Unit
V_{CC}	Supply voltage	2.5	5.5	V
T_A	Ambient operating temperature (device grade 6)	-40	85	°C
	Ambient operating temperature (device grade 3)	-40	125	°C

Table 11. Operating conditions (M95640-R device grade 6)

Symbol	Parameter	Min.	Max.	Unit
V_{CC}	Supply voltage	1.8	5.5	V
T_A	Ambient operating temperature	-40	85	°C

Table 12. AC measurement conditions⁽¹⁾

Symbol	Parameter	Min.	Max.	Unit
C_L	Load capacitance	30		pF
	Input rise and fall times		25	ns
	Input pulse voltages	0.2 V_{CC} to 0.8 V_{CC}		V
	Input and output timing reference voltages	0.3 V_{CC} to 0.7 V_{CC}		V

1. Output Hi-Z is defined as the point where data out is no longer driven.

Figure 18. AC measurement I/O waveform

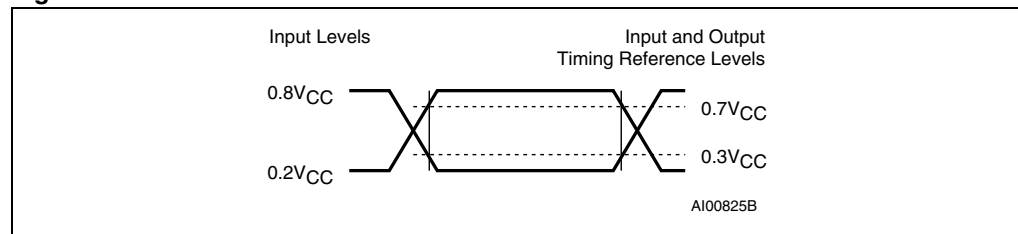

Table 13. Capacitance⁽¹⁾

Symbol	Parameter	Test condition	Max.	Unit
C_{OUT}	Output capacitance (Q)	$V_{OUT} = 0\text{ V}$	8	pF
C_{IN}	Input capacitance (D)	$V_{IN} = 0\text{ V}$	8	pF
	Input capacitance (other pins)	$V_{IN} = 0\text{ V}$	6	pF

1. Sampled only, not 100% tested.

Table 14. DC characteristics (M95640, device grade 3)

Symbol	Parameter	Test condition	Min.	Max.	Unit
I_{LI}	Input leakage current	$V_{IN} = V_{SS}$ or V_{CC}		± 2	μA
I_{LO}	Output leakage current	$\bar{S} = V_{CC}$, $V_{OUT} = V_{SS}$ or V_{CC}		± 2	μA
I_{CC}	Supply current	$C = 0.1V_{CC}/0.9V_{CC}$ at 5 MHz, $V_{CC} = 5\text{ V}$, Q = open		4	mA
		$C = 0.1V_{CC}/0.9V_{CC}$ at 10 MHz, $V_{CC} = 5\text{ V}$, Q = open		8	mA
I_{CC1}	Supply current (Standby Power mode)	$\bar{S} = V_{CC}$, $V_{CC} = 5\text{ V}$, $V_{IN} = V_{SS}$ or V_{CC}		5	μA
V_{IL}	Input low voltage		-0.45	$0.3 V_{CC}$	V
V_{IH}	Input high voltage		$0.7 V_{CC}$	$V_{CC}+1$	V
$V_{OL}^{(1)}$	Output low voltage	$I_{OL} = 2\text{ mA}$, $V_{CC} = 5\text{ V}$		0.4	V
$V_{OH}^{(1)}$	Output high voltage	$I_{OH} = -2\text{ mA}$, $V_{CC} = 5\text{ V}$	$0.8 V_{CC}$		V
$V_{RES}^{(2)}$	Internal reset threshold voltage		2.5	4.0	V

- For all 5 V range devices, the device meets the output requirements for both TTL and CMOS standards.
- Characterized only, not 100% tested.

Table 15. DC characteristics (M95640-W, device grade 6)

Symbol	Parameter	Test condition	Min.	Max.	Unit
I_{LI}	Input leakage current	$V_{IN} = V_{SS}$ or V_{CC}		± 2	μA
I_{LO}	Output leakage current	$\bar{S} = V_{CC}$, $V_{OUT} = V_{SS}$ or V_{CC}		± 2	μA
I_{CC}	Supply current (Read)	$V_{CC} = 2.5 V$, $C = 0.1V_{CC}/0.9V_{CC}$, $f_C = 5 MHz$, $Q = open$		3	mA
		$V_{CC} = 2.5 V$, $C = 0.1V_{CC}/0.9V_{CC}$, $f_C = 10 MHz$, $Q = open$		2 ⁽¹⁾	
		$V_{CC} = 5.5 V$, $C = 0.1V_{CC}/0.9V_{CC}$, $f_C = 20 MHz$, $Q = open$		5 ⁽¹⁾	
I_{CC0}	Supply current (Write)	$2.5 V < V_{CC} < 5.5 V$, during t_W , $S = V_{CC}$		5	mA
I_{CC1}	Supply current (Standby Power mode)	$\bar{S} = V_{CC}$, $V_{CC} = 5.5 V$ $V_{IN} = V_{SS}$ or V_{CC}		3 ⁽¹⁾	μA
		$\bar{S} = V_{CC}$, $V_{CC} = 5.0 V$ $V_{IN} = V_{SS}$ or V_{CC}		2	
		$\bar{S} = V_{CC}$, $V_{CC} = 2.5 V$ $V_{IN} = V_{SS}$ or V_{CC}		1 ⁽²⁾	
V_{IL}	Input low voltage		-0.45	$0.3V_{CC}$	V
V_{IH}	Input high voltage		$0.7V_{CC}$	$V_{CC}+1$	V
V_{OL}	Output low voltage	$V_{CC} = 2.5 V$ and $I_{OL} = 1.5 mA$, or $V_{CC} = 5 V$ and $I_{OL} = 2 mA$		0.4	V
V_{OH}	Output high voltage	$V_{CC} = 2.5 V$ and $I_{OH} = 0.4 mA$, or $V_{CC} = 5 V$ and $I_{OH} = 2 mA$	$0.8V_{CC}$		V
$V_{RES}^{(3)}$	Internal reset threshold voltage		1.0 ⁽⁴⁾	1.65 ⁽⁵⁾	V

1. Only for the device identified with process letter K.
2. 2 μA with the device identified with process letter K.
3. Characterized only, not 100% tested.
4. 0.7 V with the device identified with process letter K.
5. 1.3 V with the device identified with process letter K.

Table 16. DC characteristics (M95640-W, device grade 3)

Symbol	Parameter	Test condition	Min.	Max.	Unit
I_{LI}	Input leakage current	$V_{IN} = V_{SS}$ or V_{CC}		± 2	μA
I_{LO}	Output leakage current	$\bar{S} = V_{CC}$, $V_{OUT} = V_{SS}$ or V_{CC}		± 2	μA
I_{CC}	Supply current (Read)	$f_C = 5$ MHz, $V_{CC} = 2.5$ V, $C = 0.1V_{CC}/0.9V_{CC}$, Q = open		3	mA
		$f_C = 10$ MHz, $V_{CC} = 2.5$ V, $C = 0.1V_{CC}/0.9V_{CC}$, Q = open		6	
I_{CC0}	Supply current (Write)	2.5 V < V_{CC} < 5.5 V, during t_W , $\bar{S} = V_{CC}$		6	mA
I_{CC1}	Supply current (Standby Power mode)	$\bar{S} = V_{CC}$, $V_{IN} = V_{SS}$ or V_{CC} $V_{CC} = 2.5$ V		2	μA
V_{IL}	Input low voltage		-0.45	$0.3V_{CC}$	V
V_{IH}	Input high voltage		$0.7V_{CC}$	$V_{CC}+1$	V
V_{OL}	Output low voltage	$I_{OL} = 1.5$ mA, $V_{CC} = 2.5$ V		0.4	V
V_{OH}	Output high voltage	$I_{OH} = -0.4$ mA, $V_{CC} = 2.5$ V	$0.8V_{CC}$		V
$V_{RES}^{(1)}$	Internal reset threshold voltage		1.0	1.65	V

1. Characterized only, not 100% tested.

Table 17. DC characteristics (M95640-R, M95640-DR, device grade 6)⁽¹⁾

Symbol	Parameter	Test condition	Min.	Max.	Unit
I_{LI}	Input leakage current	$V_{IN} = V_{SS}$ or V_{CC}		± 2	μA
I_{LO}	Output leakage current	$\bar{S} = V_{CC}$, $V_{OUT} = V_{SS}$ or V_{CC}		± 2	μA
I_{CC}	Supply current (Read)	$V_{CC} = 1.8$ V, $C = 0.1V_{CC}/0.9V_{CC}$, Q = open, $f_C = 2$ MHz		2	mA
		$V_{CC} = 1.8$ V, $C = 0.1V_{CC}/0.9V_{CC}$, Q = open, $f_C = 5$ MHz		2	
I_{CC0}	Supply current (Write)	$V_{CC} = 1.8$ V, during t_W , $\bar{S} = V_{CC}$		5	mA
I_{CC1}	Supply current (Standby mode)	$V_{CC} = 1.8$ V, $\bar{S} = V_{CC}$, $V_{IN} = V_{SS}$ or V_{CC}		1	μA
V_{IL}	Input low voltage	1.8 V $\leq V_{CC} < 2.5$ V	-0.45	$0.25V_{CC}$	V
V_{IH}	Input high voltage	1.8 V $\leq V_{CC} < 2.5$ V	$0.75V_{CC}$	$V_{CC}+1$	V
V_{OL}	Output low voltage	$V_{CC} = 1.8$ V, $I_{OL} = 0.15$ mA		0.3	V
V_{OH}	Output high voltage	$V_{CC} = 1.8$ V, $I_{OH} = -0.1$ mA	$0.8 V_{CC}$		V
$V_{RES}^{(2)}$	Internal reset threshold voltage		$1.0^{(3)}$	$1.65^{(4)}$	V

1. If the application uses the M95640-R device with 2.5 V < V_{CC} < 5.5 V and -40 °C < T_A < $+85$ °C, please refer to [Table 15: DC characteristics \(M95640-W, device grade 6\)](#) instead of the above table.

2. Characterized only, not 100% tested.

3. 0.7 V with the device identified with process letter K.

4. 1.3 V with the device identified with process letter K.

Table 18. AC characteristics (M95640, device grade 3)

Test conditions specified in Table 9 and Table 12							
Symbol	Alt.	Parameter	Min. ⁽¹⁾	Max. ⁽¹⁾	Min. ⁽²⁾	Max. ⁽²⁾	Unit
f_C	f_{SCK}	Clock frequency	D.C.	5	D.C.	10	MHz
t_{SLCH}	t_{CSS1}	\overline{S} active setup time	90		30		ns
t_{SHCH}	t_{CSS2}	\overline{S} not active setup time	90		30		ns
t_{SHSL}	t_{CS}	\overline{S} deselect time	100		40		ns
t_{CHSH}	t_{CSH}	\overline{S} active hold time	90		30		ns
t_{CHSL}		\overline{S} not active hold time	90		30		ns
$t_{CH}^{(3)}$	t_{CLH}	Clock high time	90		42		ns
$t_{CL}^{(3)}$	t_{CLL}	Clock low time	90		40		ns
$t_{CLCH}^{(4)}$	t_{RC}	Clock rise time		1		2	μ s
$t_{CHCL}^{(4)}$	t_{FC}	Clock fall time		1		2	μ s
t_{DVCH}	t_{DSU}	Data in setup time	20		10		ns
t_{CHDX}	t_{DH}	Data in hold time	30		10		ns
t_{HHCH}		Clock low hold time after \overline{HOLD} not active	70		30		ns
t_{HLCH}		Clock low hold time after \overline{HOLD} active	40		30		ns
t_{CLHL}		Clock low set-up time before \overline{HOLD} active	0		0		ns
t_{CLHH}		Clock low set-up time before \overline{HOLD} not active	0		0		ns
$t_{SHQZ}^{(4)}$	t_{DIS}	Output disable time		100		40	ns
$t_{CLQV}^{(5)}$	t_V	Clock low to output valid		60		40	ns
t_{CLQX}	t_{HO}	Output hold time	0		0		ns
$t_{QLQH}^{(4)}$	t_{RO}	Output rise time		50		40	ns
$t_{QHQL}^{(4)}$	t_{FO}	Output fall time		50		40	ns
t_{HHQV}	t_{LZ}	\overline{HOLD} high to output valid		50		40	ns
$t_{HLQZ}^{(4)}$	t_{HZ}	\overline{HOLD} low to output high-Z		100		40	ns
t_W	t_{WC}	Write time		5		5	ms

1. These timings are offered with grade 3 devices referenced with “/P” process letters only (see the last digits in [Part numbering](#)).
2. These timings are offered with grade 3 devices referenced with “/PC” process letters only (see the last digits in [Part numbering](#)).
3. $t_{CH} + t_{CL}$ must never be lower than the shortest possible clock period, $1/f_C(\max)$.
4. Value guaranteed by characterization, not 100% tested in production.
5. t_{CLQV} must be compatible with t_{CL} (clock low time): if the SPI bus master offers a Read setup time $t_{SU} = 0$ ns, t_{CL} can be equal to (or greater than) t_{CLQV} ; in all other cases, t_{CL} must be equal to (or greater than) $t_{CLQV} + t_{SU}$.

Table 19. AC characteristics (M95640-W products, device grade 6)

Test conditions specified in Table 10 and Table 12							
Symbol	Alt.	Parameter	Min.	Max.	Min.	Max.	Unit
			V _{CC} = 2.5 to 5.5 V		New products ⁽¹⁾ V _{CC} = 4.5 to 5.5 V		
f _C	f _{SCK}	Clock frequency	D.C.	10	D.C.	20	MHz
t _{SLCH}	t _{CSS1}	\overline{S} active setup time	30		15		ns
t _{SHCH}	t _{CSS2}	\overline{S} not active setup time	30		15		ns
t _{SHSL}	t _{CS}	\overline{S} deselect time	40		20		ns
t _{CHSH}	t _{CSH}	\overline{S} active hold time	30		15		ns
t _{CHSL}		\overline{S} not active hold time	30		15		ns
t _{CH} ⁽²⁾	t _{CLH}	Clock high time	42		20		ns
t _{CL} ⁽²⁾	t _{CLL}	Clock low time	40		20		ns
t _{CLCH} ⁽³⁾	t _{RC}	Clock rise time		2		2	μs
t _{CHCL} ⁽³⁾	t _{FC}	Clock fall time		2		2	μs
t _{DVCH}	t _{DSU}	Data in setup time	10		5		ns
t _{CHDX}	t _{DH}	Data in hold time	10		10		ns
t _{HHCH}		Clock low hold time after \overline{HOLD} not active	30		15		ns
t _{HLCH}		Clock low hold time after \overline{HOLD} active	30		15		ns
t _{CLHL}		Clock low set-up time before \overline{HOLD} active	0		0		ns
t _{CLHH}		Clock low set-up time before \overline{HOLD} not active	0		0		ns
t _{SHQZ} ⁽³⁾	t _{DIS}	Output disable time		40		20	ns
t _{CLQV} ⁽⁴⁾	t _V	Clock low to output valid		40		20	ns
t _{CLQX}	t _{HO}	Output hold time	0		0		ns
t _{QLQH} ⁽³⁾	t _{RO}	Output rise time		40		20	ns
t _{QHQL} ⁽³⁾	t _{FO}	Output fall time		40		20	ns
t _{HHQV}	t _{LZ}	\overline{HOLD} high to output valid		40		20	ns
t _{HLQZ} ⁽³⁾	t _{HZ}	\overline{HOLD} low to output high-Z		40		20	ns
t _W	t _{WC}	Write time		5		5	ms

1. Preliminary data for the devices identified with process letter K.
2. t_{CH} + t_{CL} must never be lower than the shortest possible clock period, 1/f_C(max).
3. Value guaranteed by characterization, not 100% tested in production.
4. t_{CLQV} must be compatible with t_{CL} (clock low time): if the SPI bus master offers a Read setup time t_{SU} = 0 ns, t_{CL} can be equal to (or greater than) t_{CLQV}; in all other cases, t_{CL} must be equal to (or greater than) t_{CLQV}+t_{SU}.

Table 20. AC characteristics (M95640-W products, device grade 3)

Test conditions: $V_{CC} = 2.5$ to 5.5 V, $T_A = -40$ to 125°C							
Symbol	Alt.	Parameter	Min.	Max.	Min.	Max.	Unit
			2.5 V to 5.5 V ⁽¹⁾		3.0 V to 5.5 V ⁽²⁾		
f_C	f_{SCK}	Clock frequency	D.C.	5	D.C.	10	MHz
t_{SLCH}	t_{CSS1}	\overline{S} active setup time	90		30		ns
t_{SHCH}	t_{CSS2}	\overline{S} not active setup time	90		30		ns
t_{SHSL}	t_{CS}	\overline{S} deselect time	100		40		ns
t_{CHSH}	t_{CSH}	\overline{S} active hold time	90		30		ns
t_{CHSL}		\overline{S} not active hold time	90		30		ns
$t_{CH}^{(3)}$	t_{CLH}	Clock high time	90		42		ns
$t_{CL}^{(3)}$	t_{CLL}	Clock low time	90		40		ns
$t_{CLCH}^{(4)}$	t_{RC}	Clock rise time		1		2	μs
$t_{CHCL}^{(4)}$	t_{FC}	Clock fall time		1		2	μs
t_{DVCH}	t_{DSU}	Data in setup time	20		10		ns
t_{CHDX}	t_{DH}	Data in hold time	30		10		ns
t_{HHCH}		Clock low hold time after \overline{HOLD} not active	70		30		ns
t_{HLCH}		Clock low hold time after \overline{HOLD} active	40		30		ns
t_{CLHL}		Clock low set-up time before \overline{HOLD} active	0		0		ns
t_{CLHH}		Clock low set-up time before \overline{HOLD} not active	0		0		ns
$t_{SHQZ}^{(4)}$	t_{DIS}	Output disable time		100		40	ns
$t_{CLQV}^{(5)}$	t_V	Clock low to output valid		60		40	ns
t_{CLQX}	t_{HO}	Output hold time	0		0		ns
$t_{QLQH}^{(4)}$	t_{RO}	Output rise time		50		40	ns
$t_{QHQL}^{(4)}$	t_{FO}	Output fall time		50		40	ns
t_{HHQV}	t_{LZ}	\overline{HOLD} high to output valid		50		40	ns
$t_{HLQZ}^{(4)}$	t_{HZ}	\overline{HOLD} low to output high-Z		100		40	ns
t_W	t_{WC}	Write time		5		5	ms

1. These timings are offered with grade 3 devices referenced with "/P" process letters only (see the last digits in [Part numbering](#)).
2. These timings are offered with grade 3 devices referenced with "/PC" process letters only (see the last digits in [Part numbering](#)).
3. $t_{CH} + t_{CL}$ must never be lower than the shortest possible clock period, $1/f_C(\text{max})$.
4. Value guaranteed by characterization, not 100% tested in production.
5. t_{CLQV} must be compatible with t_{CL} (clock low time): if the SPI bus master offers a Read setup time $t_{SU} = 0$ ns, t_{CL} can be equal to (or greater than) t_{CLQV} ; in all other cases, t_{CL} must be equal to (or greater than) $t_{CLQV} + t_{SU}$.

Table 21. AC characteristics (M95640-R, M95640-DR devices, grade 6)

Test conditions specified in Table 11 and Table 13							
Symbol	Alt.	Parameter	Min.	Max.	Min.	Max.	Unit
			Current products ⁽¹⁾		New products ⁽²⁾		
f_C	f_{SCK}	Clock frequency	D.C.	2	D.C.	5	MHz
t_{SLCH}	t_{CSS1}	\overline{S} active setup time	150		60		ns
t_{SHCH}	t_{CSS2}	\overline{S} not active setup time	150		60		ns
t_{SHSL}	t_{CS}	\overline{S} deselect time	200		90		ns
t_{CHSH}	t_{CSH}	\overline{S} active hold time	150		60		ns
t_{CHSL}		\overline{S} not active hold time	150		60		ns
$t_{CH}^{(3)}$	t_{CLH}	Clock high time	200		80		ns
$t_{CL}^{(2)}$	t_{CLL}	Clock low time	200		80		ns
$t_{CLCH}^{(4)}$	t_{RC}	Clock rise time		2		2	μ s
$t_{CHCL}^{(3)}$	t_{FC}	Clock fall time		2		2	μ s
t_{DVCH}	t_{DSU}	Data in setup time	50		20		ns
t_{CHDX}	t_{DH}	Data in hold time	50		20		ns
t_{HHCH}		Clock low hold time after \overline{HOLD} not active	150		60		ns
t_{HLCH}		Clock low hold time after \overline{HOLD} active	150		60		ns
t_{CLHL}		Clock low set-up time before \overline{HOLD} active	0		0		0
t_{CLHH}		Clock low set-up time before \overline{HOLD} not active	0		0		0
$t_{SHQZ}^{(3)}$	t_{DIS}	Output disable time		200		80	ns
$t_{CLQV}^{(5)}$	t_V	Clock low to output valid		200		80	ns
t_{CLQX}	t_{HO}	Output hold time	0		0		ns
$t_{QLQH}^{(3)}$	t_{RO}	Output rise time		200		80	ns
$t_{QHQL}^{(3)}$	t_{FO}	Output fall time		200		80	ns
t_{HHQV}	t_{LZ}	\overline{HOLD} high to output valid		200		80	ns
$t_{HLQZ}^{(3)}$	t_{HZ}	\overline{HOLD} low to output high-Z		200		80	ns
t_W	t_{WC}	Write time		5		5	ms

1. Current products are identified by process letters P.
2. Preliminary data for the new products identified by process letter K. If the application uses the M95640-R device with $2.5\text{ V} < V_{CC} < 5.5\text{ V}$ and $-40\text{ }^\circ\text{C} < T_A < +85\text{ }^\circ\text{C}$, please refer to [Table 19: AC characteristics \(M95640-W products, device grade 6\)](#) instead of the above table.
3. $t_{CH} + t_{CL}$ must never be lower than the shortest possible clock period, $1/f_C(\text{max})$.
4. Value guaranteed by characterization, not 100% tested in production.
5. t_{CLQV} must be compatible with t_{CL} (clock low time): if the SPI bus master offers a Read setup time $t_{SU} = 0\text{ ns}$, t_{CL} can be equal to (or greater than) t_{CLQV} ; in all other cases, t_{CL} must be equal to (or greater than) $t_{CLQV} + t_{SU}$.

Figure 19. Serial input timing

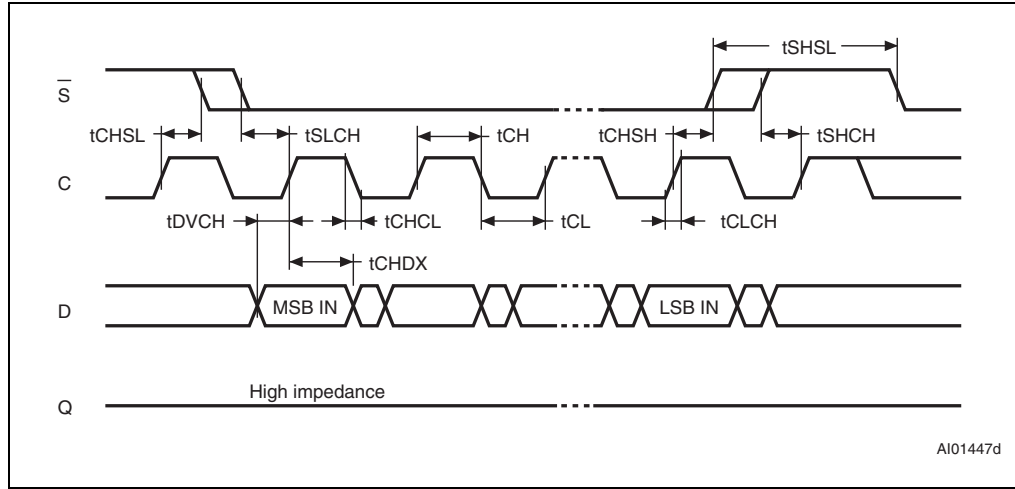

Figure 20. Hold timing

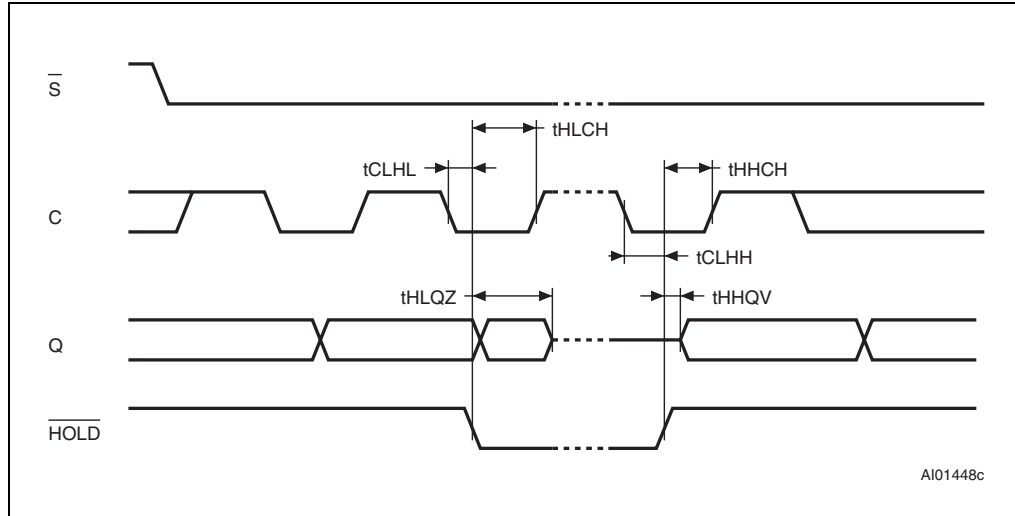
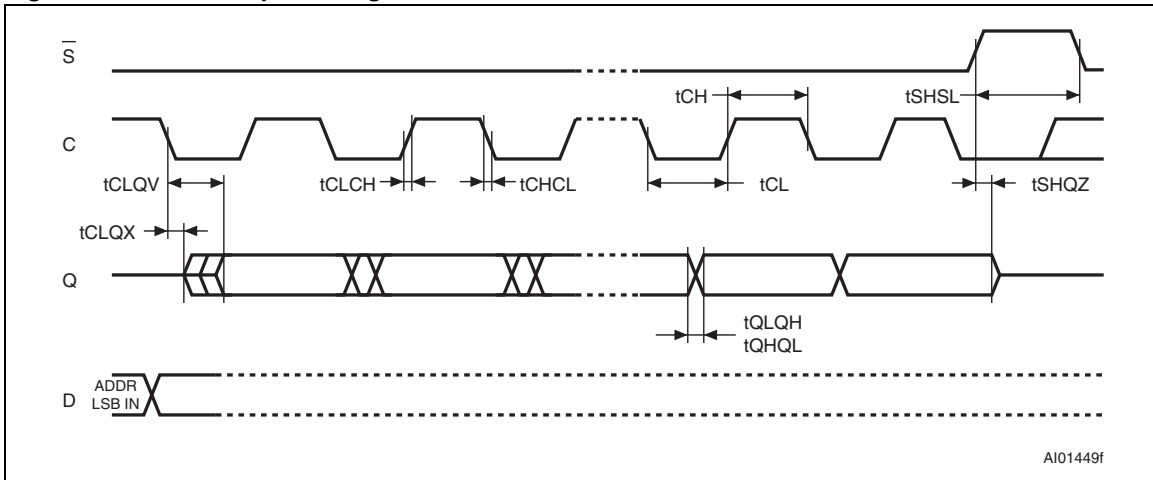

Figure 21. Serial output timing



10 Package mechanical data

In order to meet environmental requirements, ST offers these devices in different grades of ECOPACK® packages, depending on their level of environmental compliance. ECOPACK® specifications, grade definitions and product status are available at: www.st.com. ECOPACK® is an ST trademark.

Figure 22. SO8N – 8-lead plastic small outline, 150 mils body width, package outline

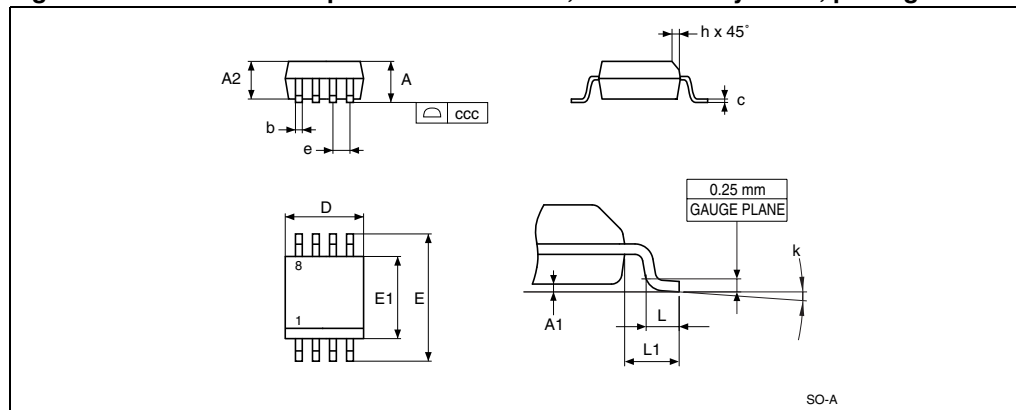

1. Drawing is not to scale.

Table 22. SO8N – 8-lead plastic small outline, 150 mils body width, package mechanical data

Symbol	millimeters			inches ⁽¹⁾		
	Typ	Min	Max	Typ	Min	Max
A			1.75			0.0689
A1		0.10	0.25		0.0039	0.0098
A2		1.25			0.0492	
b		0.28	0.48		0.011	0.0189
c		0.17	0.23		0.0067	0.0091
ccc			0.10			0.0039
D	4.90	4.80	5.00	0.1929	0.189	0.1969
E	6.00	5.80	6.20	0.2362	0.2283	0.2441
E1	3.90	3.80	4.00	0.1535	0.1496	0.1575
e	1.27	–	–	0.05	-	-
h		0.25	0.50		0.0098	0.0197
k		0°	8°		0°	8°
L		0.40	1.27		0.0157	0.05
L1	1.04			0.0409		

1. Values in inches are converted from mm and rounded to 4 decimal digits.

Figure 23. TSSOP8 – 8-lead thin shrink small outline, package outline

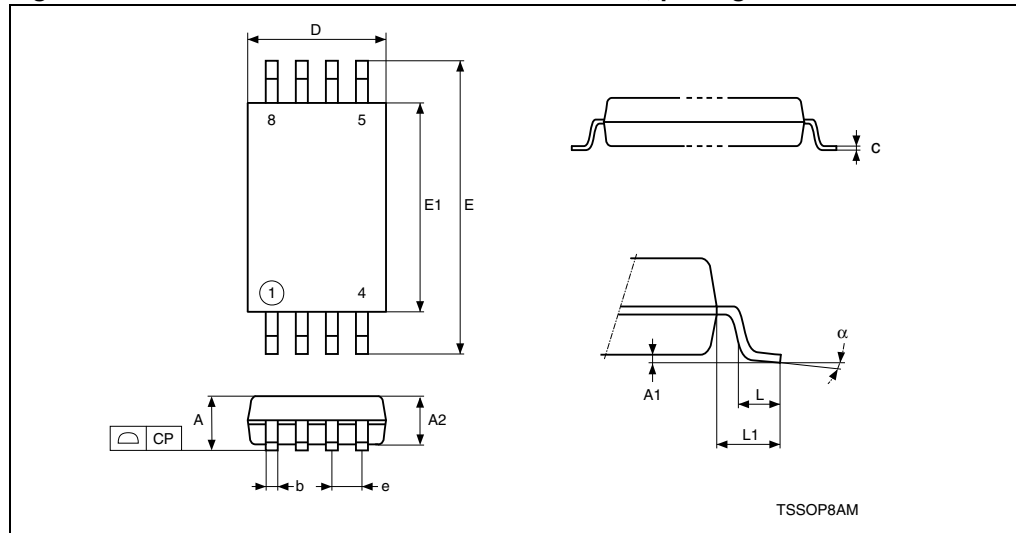

1. Drawing is not to scale.

Table 23. TSSOP8 – 8-lead thin shrink small outline, package mechanical data

Symbol	millimeters			inches ⁽¹⁾		
	Typ.	Min.	Max.	Typ.	Min.	Max.
A			1.200			0.0472
A1		0.050	0.150		0.0020	0.0059
A2	1.000	0.800	1.050	0.0394	0.0315	0.0413
b		0.190	0.300		0.0075	0.0118
c		0.090	0.200		0.0035	0.0079
CP			0.100			0.0039
D	3.000	2.900	3.100	0.1181	0.1142	0.1220
e	0.650	–	–	0.0256	–	–
E	6.400	6.200	6.600	0.2520	0.2441	0.2598
E1	4.400	4.300	4.500	0.1732	0.1693	0.1772
L	0.600	0.450	0.750	0.0236	0.0177	0.0295
L1	1.000			0.0394		
α		0°	8°		0°	8°

1. Values in inches are converted from mm and rounded to 4 decimal digits.

Figure 24. UFDFPN8 (MLP8) - 8-lead ultra thin fine pitch dual flat no lead, package outline

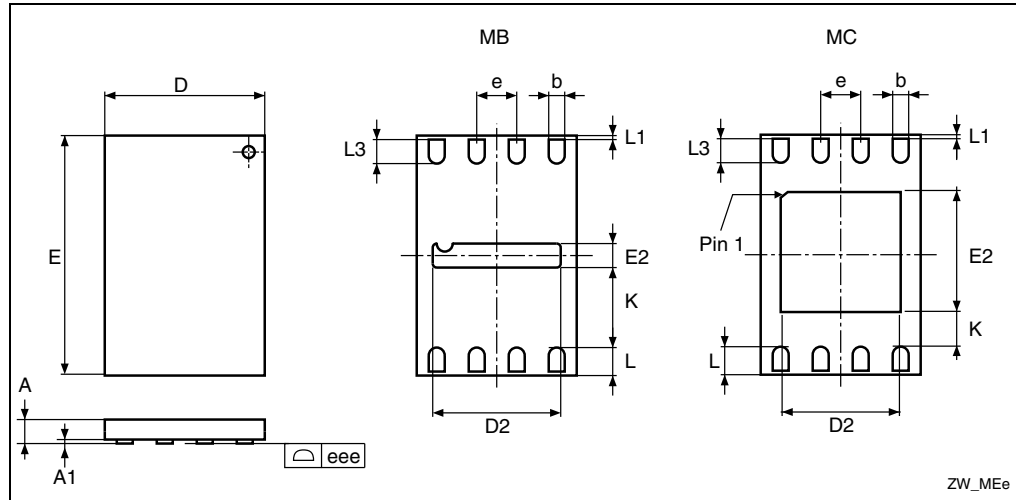

1. Drawing is not to scale.
2. The central pad (the area E2 by D2 in the above illustration) is internally pulled to V_{SS} . It must not be connected to any other voltage or signal line on the PCB, for example during the soldering process.

Table 24. UFDFPN8 (MLP8) 8-lead ultra thin fine pitch dual flat package no lead 2 x 3 mm, data

Symbol	millimeters			inches ⁽¹⁾		
	Typ	Min	Max	Typ	Min	Max
A	0.550	0.450	0.600	0.0217	0.0177	0.0236
A1	0.020	0.000	0.050	0.0008	0.0000	0.0020
b	0.250	0.200	0.300	0.0098	0.0079	0.0118
D	2.000	1.900	2.100	0.0787	0.0748	0.0827
D2 (rev MB)	1.600	1.500	1.700	0.0630	0.0591	0.0669
D2 (rev MC)		1.200	1.600		0.0472	0.0630
E	3.000	2.900	3.100	0.1181	0.1142	0.1220
E2 (rev MB)	0.200	0.100	0.300	0.0079	0.0039	0.0118
E2 (rev MC)		1.200	1.600		0.0472	0.0630
e	0.500			0.0197		
K		0.300			0.0118	
L		0.300	0.500		0.0118	0.0197
L1			0.150			0.0059
L3		0.300			0.0118	
eee ⁽²⁾		0.080			0.0031	

1. Values in inches are converted from mm and rounded to 4 decimal digits.
2. Applied for exposed die paddle and terminals. Exclude embedding part of exposed die paddle from measuring.

11 Part numbering

Table 25. Ordering information scheme

Example:	M95640	-	W	MN	6	T	P	/P
Device type M95 = SPI serial access EEPROM								
Device function 640 = 64 Kbit (8192 × 8) 640-D = 64 Kbit (8192 × 8) plus Identification Page								
Operating voltage blank = $V_{CC} = 4.5$ to 5.5 V W = $V_{CC} = 2.5$ to 5.5 V R = $V_{CC} = 1.8$ to 5.5 V								
Package⁽¹⁾ MN = SO8 (150 mils width) DW = TSSOP8 (169 mils width) MB or MC = MLP8 (2 × 3 mm)								
Device grade 6 = Industrial temperature range, -40 to 85 °C. Device tested with standard test flow 3 = Device tested with high reliability certified flow ⁽²⁾ automotive temperature range (-40 to 125 °C)								
Option blank = Standard packing T = Tape and reel packing								
Plating technology P or G = ECOPACK (RoHS compliant)								
Process letter⁽³⁾ /P or /PC = DP26% K = F8H								

1. All packages are ECOPACK2[®] (RoHS compliant and Halogen-free).
2. ST strongly recommends the use of the Automotive Grade devices for use in an automotive environment. The high reliability certified flow (HRCF) is described in the quality note QNEE9801. Please ask your nearest ST sales office for a copy.
3. Used only for devices grade 3.

For a list of available options (speed, package, etc.) or for further information on any aspect of this device, please contact your nearest ST sales office.

12 Revision history

Table 26. Document revision history

Date	Revision	Changes
13-Jul-2000	1.2	Human Body Model meets JEDEC std (Table 2). Minor adjustments on pp 1,11,15. New clause on p7. Addition of TSSOP8 package on pp 1, 2, Ordering Info, Mechanical Data
16-Mar-2001	1.3	Test condition added I_{LI} and I_{LO} , and specification of t_{DLDH} and t_{DHDL} removed. t_{CLCH} , t_{CHCL} , t_{DLDH} and t_{DHDL} changed to 50ns for the -V range. “-V” Voltage range changed to “2.7V to 3.6V” throughout. Maximum lead soldering time and temperature conditions updated. Instruction sequence illustrations updated. “Bus Master and Memory Devices on the SPI bus” illustration updated. Package Mechanical data updated
19-Jul-2001	1.4	M95160 and M95080 devices removed to their own data sheet
06-Dec-2001	1.5	Endurance increased to 1M write/erase cycles Instruction sequence illustrations updated
18-Dec-2001	2.0	Document reformatted using the new template. No parameters changed.
08-Feb-2002	2.1	Announcement made of planned upgrade to 10MHz clock for the 5V, -40 to 85°C, range. Endurance set to 100K write/erase cycles
18-Dec-2002	2.2	10MHz, 5MHz, 2MHz clock; 5ms, 10ms Write Time; 100K, 1M erase/write cycles distinguished on front page, and in the DC and AC Characteristics tables
26-Mar-2003	2.3	Process identification letter corrected in footnote to AC Characteristics table for temp. range 3
26-Jun-2003	2.4	-S voltage range upgraded by removing it and inserting -R voltage range in its place
15-Oct-2003	3.0	Table of contents, and Pb-free options added. $V_{IL}(\min)$ improved to -0.45V
21-Nov-2003	3.1	$V_I(\min)$ and $V_O(\min)$ corrected (improved) to -0.45V
28-Jan-2004	4.0	TSSOP8 connections added to DIP and SO connections
24-May-2005	5.0	M95320-S and M95640-S root part numbers (1.65 to 5.5V Supply) and related characteristics added. 20MHz Clock rate added. TSSOP14 package removed and MLP8 package added. Description of <i>Power On Reset: VCC Lock-Out Write Protect</i> updated. Product List summary table added. Absolute Maximum Ratings for $V_{IO}(\min)$ and $V_{CC}(\min)$ improved. Soldering temperature information clarified for RoHS compliant devices. Device Grade 3 clarified, with reference to HRCF and automotive environments. AEC-Q100-002 compliance. $t_{CHHL}(\min)$ and $t_{CHHH}(\min)$ is t_{CH} for products under “S” process. t_{HHQX} corrected to t_{HHQV} . <i>Figure 20: Hold timing</i> updated.

Table 26. Document revision history (continued)

Date	Revision	Changes
07-Jul-2006	6	<p>Document converted to new ST template.</p> <p>Packages are ECOPACK® compliant. PDIP package removed.</p> <p>SO8N package specifications updated (see Table 22 and Figure 22).</p> <p>M95640-S and M95320-S part numbers removed (DC and AC parameters updated accordingly).</p> <p>How to identify previous, current and new products by the Process identification letter Table removed.</p> <p>Figure 4: SPI modes supported updated and Note 2 added. First three paragraphs of Section 4: Operating features replaced by Section 4.1: Supply voltage (VCC).</p> <p>T_A added to Table 8: Absolute maximum ratings. I_{CC} and I_{CC1} updated in Table 13, Table 14, Table 15 and Table 19. V_{OL} and V_{OH} updated in Table 15. I_{CC} updated in Table 16. Data in Table 19 is no longer preliminary.</p> <p>t_{CH} updated in Table 19. Table 21: AC characteristics (M95640-R) added.</p> <p>Timing line of t_{SHQZ} modified in Figure 21: Serial output timing.</p> <p>Process letter added to Table 25: Ordering information scheme, Note 2 removed. Note 2 removed from Figure 2.</p>
09-Oct-2007	7	<p>JEDEC standard revision updated to D in Note 1 below Table 8: Absolute maximum ratings.</p> <p>Note 2 removed below Figure 3 and explanatory paragraph added.</p> <p>Section 4.1: Supply voltage (VCC) updated. Table 7: Address range bits corrected.</p> <p>Products operating at V_{CC} = 4.5 V to 5.5 V are no longer available in the device grade 6 T_A temperature range.</p> <p>I_{CC} and I_{CC1} parameters modified in Table 15: DC characteristics (M95640-W, device grade 6).</p> <p>Maximum frequency for M95320-W and M95640-W upgraded from 5 MHz to 10 MHz in the device grade 6 T_A temperature range (Table 19: AC characteristics (M95640-W products, device grade 6) modified accordingly).</p> <p>Table 27: Available M95640x products (package, voltage range, temperature grade): /PB process letter added, /P process letter removed.</p> <p>Blank option removed below Plating technology in Table 25: Ordering information scheme.</p> <p>Table 25 and Table 27 added. Small text changes.</p> <p>Table 24: UFDFPN8 (MLP8) - 8-lead ultra thin fine pitch dual flat no lead, package mechanical data updated.</p> <p>Package mechanical inch values calculated from mm and rounded to 4 decimal digits in Section 10: Package mechanical data.</p>
17-Dec-2007	8	<p>Section 2.7: VSS ground added.</p> <p>Device behavior when V_{CC} passes over the POR threshold updated (see Section 4.1.2: Device reset and Section 4.1.4: Power-down).</p> <p>V_{IL} and V_{IH} modified in Table 19: DC characteristics (M95640-DF, device grade 6).</p> <p>t_W, write time, modified in Table 20: AC characteristics (M95320-R) and Table 21: AC characteristics (M95640-R). Small text changes.</p>

Table 26. Document revision history (continued)

Date	Revision	Changes
20-Mar-2008	9	<p><i>Section 4.1: Supply voltage (VCC)</i> updated.</p> <p>10 MHz frequencies added to <i>Table 18: AC characteristics (M95640, device grade 3)</i> and <i>Table 20: AC characteristics (M95640-W products, device grade 3)</i>.</p> <p>Small text changes.</p>
23-Jun-2008	10	<p><i>Section 4.1: Supply voltage (VCC)</i> updated.</p> <p><i>Table 19: DC characteristics (M95640-DF, device grade 6)</i> modified.</p> <p><i>Figure 19: Serial input timing</i>, <i>Figure 20: Hold timing</i> and <i>Figure 21: Serial output timing</i> modified.</p>
17-Feb-2009	11	<p><i>Section 4.1: Supply voltage (VCC)</i> and <i>Section 6.4: Write Status Register (WRSR)</i> updated.</p> <p>Note added to <i>Section 6.6: Write to Memory Array (WRITE)</i>.</p> <p><i>Section 7.2: Initial delivery state</i> specified.</p> <p>Note modified in <i>Table 13: Capacitance</i>. I_{CC} at 10 MHz added to <i>Table 14: DC characteristics (M95640, device grade 3)</i>.</p> <p>V_{RES} parameter added to DC characteristics tables <i>14</i>, <i>15</i>, <i>16</i> and <i>19</i>.</p> <p>Note added to t_{CLQV} in AC characteristics tables <i>18</i>, <i>19</i>, <i>20</i> and <i>21</i>.</p> <p>Note added to <i>Table 20: AC characteristics (M95320-R)</i> and <i>Table 21: AC characteristics (M95640-R)</i>.</p> <p>Process letter modified in <i>Table 25: Ordering information scheme</i>.</p>
07-Dec-2009	12	<p>32 Kbit densities removed from datasheet.</p> <p>ECOPACK status of packages specified in <i>Features</i> and in <i>Table 25: Ordering information scheme</i>.</p> <p>I_{OL} and I_{OH} added to <i>Table 8: Absolute maximum ratings</i>.</p> <p><i>Note 2</i> added below <i>Figure 24: UFDFPN8 (MLP8) - 8-lead ultra thin fine pitch dual flat no lead, package outline</i>.</p> <p>Small text changes.</p>
21-Dec-2010	13	<p>Added part number M95640-DR.</p> <p>Updated <i>Features</i>, <i>Section 1: Description</i>, <i>Section 6.4: Write Status Register (WRSR)</i>, <i>Section 6.6: Write to Memory Array (WRITE)</i>, <i>Table 8: Absolute maximum ratings</i>, all tables in <i>Section 9: DC and AC parameters</i>, <i>Section 11: Part numbering</i>.</p> <p>Added <i>Table 4: M95640-DR instruction set</i>, <i>Section 6.7: Read Identification Page</i>, <i>Section 6.9: Read Lock Status</i>, <i>Section 6.10: Lock ID</i>, <i>Figure 16: Read Lock Status sequence</i>, <i>Figure 17: Lock ID sequence</i>, <i>Table 27: Available M95640-DR products (package, voltage range, temperature grade)</i>.</p> <p>Replaced <i>Table 24</i>.</p>

Table 26. Document revision history (continued)

Date	Revision	Changes
02-Feb-2011	14	Updated: - UDFPN8 package under Features - Icc @ 10M Hz in Table 15 - note ⁽¹⁾ under Table 19 - note ⁽¹⁾ under Table 21 - layout of Table 8 Added references to M95640-DR in titles of tables 17 and 21 . Deleted Table 26 Available M95640x products (package, voltage range, temperature grade) and Table 27 Available M95640-DR products (package, voltage range, temperature grade) .
07-Apr-2011	15	Updated MLP8 package data.

Please Read Carefully:

Information in this document is provided solely in connection with ST products. STMicroelectronics NV and its subsidiaries ("ST") reserve the right to make changes, corrections, modifications or improvements, to this document, and the products and services described herein at any time, without notice.

All ST products are sold pursuant to ST's terms and conditions of sale.

Purchasers are solely responsible for the choice, selection and use of the ST products and services described herein, and ST assumes no liability whatsoever relating to the choice, selection or use of the ST products and services described herein.

No license, express or implied, by estoppel or otherwise, to any intellectual property rights is granted under this document. If any part of this document refers to any third party products or services it shall not be deemed a license grant by ST for the use of such third party products or services, or any intellectual property contained therein or considered as a warranty covering the use in any manner whatsoever of such third party products or services or any intellectual property contained therein.

UNLESS OTHERWISE SET FORTH IN ST'S TERMS AND CONDITIONS OF SALE ST DISCLAIMS ANY EXPRESS OR IMPLIED WARRANTY WITH RESPECT TO THE USE AND/OR SALE OF ST PRODUCTS INCLUDING WITHOUT LIMITATION IMPLIED WARRANTIES OF MERCHANTABILITY, FITNESS FOR A PARTICULAR PURPOSE (AND THEIR EQUIVALENTS UNDER THE LAWS OF ANY JURISDICTION), OR INFRINGEMENT OF ANY PATENT, COPYRIGHT OR OTHER INTELLECTUAL PROPERTY RIGHT.

UNLESS EXPRESSLY APPROVED IN WRITING BY AN AUTHORIZED ST REPRESENTATIVE, ST PRODUCTS ARE NOT RECOMMENDED, AUTHORIZED OR WARRANTED FOR USE IN MILITARY, AIR CRAFT, SPACE, LIFE SAVING, OR LIFE SUSTAINING APPLICATIONS, NOR IN PRODUCTS OR SYSTEMS WHERE FAILURE OR MALFUNCTION MAY RESULT IN PERSONAL INJURY, DEATH, OR SEVERE PROPERTY OR ENVIRONMENTAL DAMAGE. ST PRODUCTS WHICH ARE NOT SPECIFIED AS "AUTOMOTIVE GRADE" MAY ONLY BE USED IN AUTOMOTIVE APPLICATIONS AT USER'S OWN RISK.

Resale of ST products with provisions different from the statements and/or technical features set forth in this document shall immediately void any warranty granted by ST for the ST product or service described herein and shall not create or extend in any manner whatsoever, any liability of ST.

ST and the ST logo are trademarks or registered trademarks of ST in various countries.

Information in this document supersedes and replaces all information previously supplied.

The ST logo is a registered trademark of STMicroelectronics. All other names are the property of their respective owners.

© 2011 STMicroelectronics - All rights reserved

STMicroelectronics group of companies

Australia - Belgium - Brazil - Canada - China - Czech Republic - Finland - France - Germany - Hong Kong - India - Israel - Italy - Japan - Malaysia - Malta - Morocco - Philippines - Singapore - Spain - Sweden - Switzerland - United Kingdom - United States of America

www.st.com