

# MC10H350

## PECL\* to TTL Translator

(+5 Vdc Power Supply Only)

### Description

The MC10H350 is a member of the 10H family of high performance ECL logic. It consists of 4 translators with differential inputs and TTL outputs. The 3-state outputs can be disabled by applying a HIGH TTL logic level on the common OE input.

The MC10H350 is designed to be used primarily in systems incorporating both ECL and TTL logic operating off a common power supply. The separate  $V_{CC}$  power pins are not connected internally and thus isolate the noisy TTL  $V_{CC}$  runs from the relatively quiet ECL  $V_{CC}$  runs on the printed circuit board. The differential inputs allow the MC10H350 to be used as an inverting or noninverting translator, or a differential line receiver. The MC10H350 can also drive CMOS with the addition of a pullup resistor.

### Features

- Propagation Delay, 3.5 ns Typical
- MECL 10K™ Compatible
- Pb-Free Packages are Available\*



ON Semiconductor®

<http://onsemi.com>

### MARKING DIAGRAMS\*

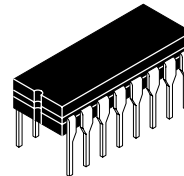

CDIP-16  
L SUFFIX  
CASE 620A

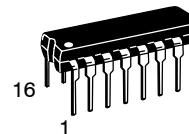
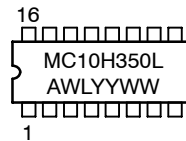

PDIP-16  
P SUFFIX  
CASE 648

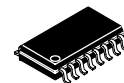
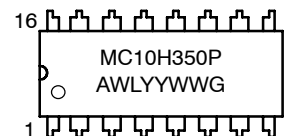

SOEIAJ-16  
CASE 966

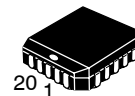
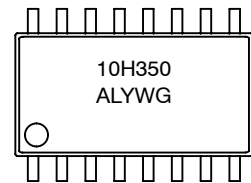

PLLC-20  
FN SUFFIX  
CASE 775

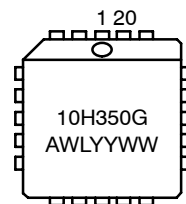

A = Assembly Location  
WL, L = Wafer Lot  
YY, Y = Year  
WW, W = Work Week  
G = Pb-Free Package

\*For additional marking information, refer to Application Note AND8002/D.

\*For additional information on our Pb-Free strategy and soldering details, please download the ON Semiconductor Soldering and Mounting Techniques Reference Manual, SOLDERRM/D.

### ORDERING INFORMATION

See detailed ordering and shipping information in the package dimensions section on page 4 of this data sheet.

# MC10H350

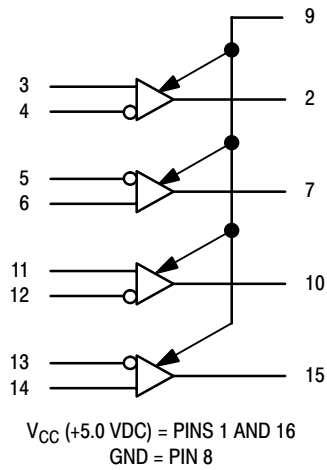

**Figure 1. Logic Diagram**

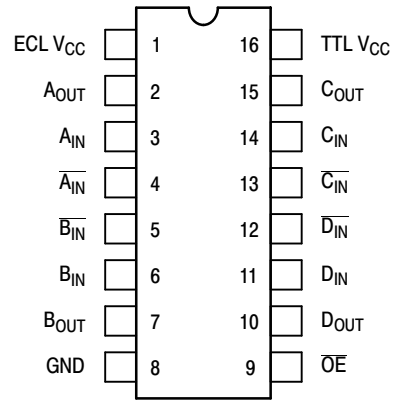

Pin assignment is for Dual-in-Line Package.

**Figure 2. Dip Pin Assignment**

**Table 1. MAXIMUM RATINGS**

Symbol	Characteristic	Rating	Unit
$V_{CC}$	Power Supply ( $V_{EE} = GND$ )	7.0	Vdc
$T_A$	Operating Temperature Range	0 to +75	°C
$T_{stg}$	Storage Temperature Range – Plastic	-55 to +150	°C
	– Ceramic	-55 to +165	°C

Maximum ratings are those values beyond which device damage can occur. Maximum ratings applied to the device are individual stress limit values (not normal operating conditions) and are not valid simultaneously. If these limits are exceeded, device functional operation is not implied, damage may occur and reliability may be affected.

# MC10H350

**Table 2. ELECTRICAL CHARACTERISTICS** ( $V_{CC} = 5.0\text{ V} \pm 5\%$ ) (Note 1)

Symbol	Characteristic	$T_A = 0^\circ\text{C to } 75^\circ\text{C}$		Unit	
		Min	Max		
$I_{CC}$	Power Supply Current	TTL	–	20	mA
		ECL	–	12	
$I_{IH}$ $I_{INH}$	Input Current High	Pin 9	–	20	$\mu\text{A}$
		Others	–	50	
$I_{IL}$ $I_{INL}$	Input Current Low	Pin 9	–	–0.6	mA
		Others	–	50	
$V_{IH}$	Input Voltage High	Pin 9	2.0	–	Vdc
$V_{IL}$	Input Voltage Low	Pin 9	–	0.8	Vdc
$V_{DIFF}$	Differential Input Voltage (Note 1) Pins 3–6, 11–14 (1)		350	–	mV
$V_{CM}$	Voltage Common Mode Pins 3–6, 11–14		2.8	$V_{CC}$	Vdc
$V_{OH}$	Output Voltage High $I_{OH} = 3.0\text{ mA}$		2.7	–	Vdc
$V_{OL}$	Output Voltage Low $I_{OL} = 20\text{ mA}$		–	0.5	Vdc
$I_{OS}$	Short Circuit Current $V_{OUT} = 0\text{ V}$		–60	–150	mA
$I_{OZH}$	Output Disable Current High $V_{OUT} = 2.7\text{ V}$		–	50	$\mu\text{A}$
$I_{OZL}$	Output Disable Current Low $V_{OUT} = 0.5\text{ V}$		–	–50	$\mu\text{A}$

\*Positive Emitter Coupled Logic

1. Common mode input voltage to pins 3–4, 5–6, 11–12, 13–14 must be between the values of 2.8 V and 5.0 V. This common mode input voltage range includes the differential input swing.
2. For single-ended use, apply 3.75 V ( $V_{BB}$ ) to either input depending on output polarity required. Signal level range to other input is 3.3 V to 4.2 V.
3. Any unused gates should have the inverting inputs tied to  $V_{CC}$  and the noninverting inputs tied to ground to prevent output glitching.

**Table 3. AC PARAMETERS** ( $C_L = 50\text{ pF}$ ) ( $V_{CC} = 5.0 \pm 5\%$ ) ( $T_A = 0^\circ\text{C to } 75^\circ\text{C}$ )

Symbol	Characteristic	$T_A = 0^\circ\text{C to } 75^\circ\text{C}$		Unit
		Min	Max	
$t_{pd}$	Propagation Delay Data (50% to 1.5 V)	1.5	5.0	ns
$t_r$	Rise Time (Note 4)	0.3	1.6	ns
$t_f$	Fall Time (Note 4)	0.3	1.6	ns
$t_{pdLZ}$ $t_{pdHZ}$	Output Disable Time	2.0	6.0	ns
		2.0	6.0	
$t_{pdZL}$ $t_{pdZH}$	Output Enable Time	2.0	8.0	ns
		2.0	8.0	

NOTE: Device will meet the specifications after thermal equilibrium has been established when mounted in a test socket or printed circuit board with maintained transverse airflow greater than 500 lfm. Electrical parameters are guaranteed only over the declared operating temperature range. Functional operation of the device exceeding these conditions is not implied. Device specification limit values are applied individually under normal operating conditions and not valid simultaneously.

4. 1.0 V to 2.0 V w/50 pF into 500  $\Omega$ .

# MC10H350

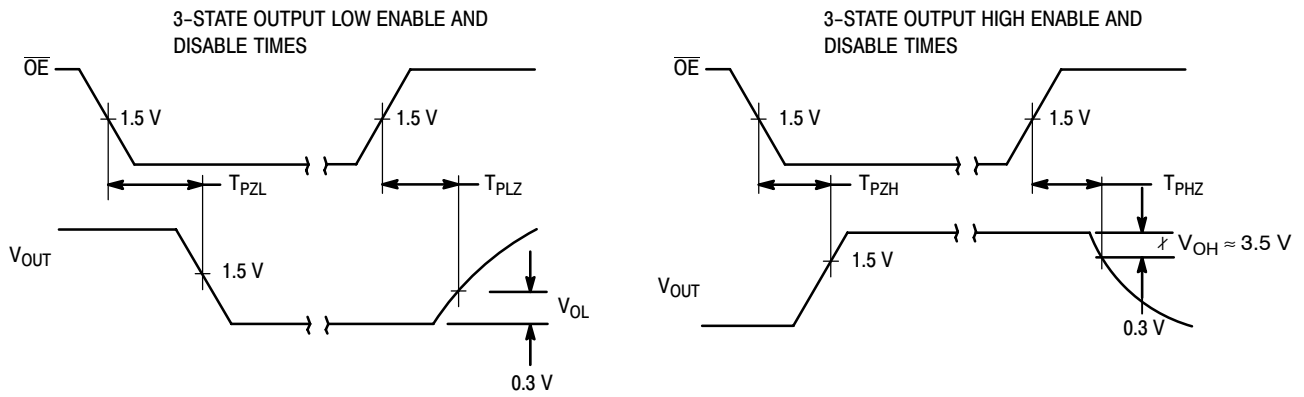

**Figure 3. 3-State Switching Waveforms**

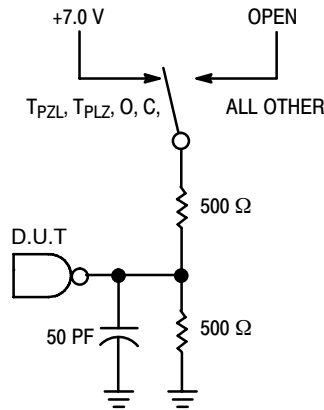

\*INCLUDES JIG AND PROBE CAPACITANCE

Application Note: Pin 9 is an  $\overline{OE}$  and the MC10H350 is disabled when  $\overline{OE}$  is at  $V_{IH}$  or higher.

**Figure 4. Test Load**

## ORDERING INFORMATION

Device	Package	Shipping <sup>†</sup>
MC10H350FN	PLLC-20	46 Units / Rail
MC10H350FNG	PLLC-20 (Pb-Free)	46 Units / Rail
MC10H350FNR2	PLLC-20	500 / Tape & Reel
MC10H350FNR2G	PLLC-20 (Pb-Free)	500 / Tape & Reel
MC10H350L	CDIP-16	25 Unit / Rail
MC10H350M	SOEIAJ-16	50 Unit / Rail
MC10H350MG	SOEIAJ-16 (Pb-Free)	50 Unit / Rail
MC10H350MEL	SOEIAJ-16	2000 / Tape & Reel
MC10H350MELG	SOEIAJ-16 (Pb-Free)	2000 / Tape & Reel
MC10H350P	PDIP-16	25 Unit / Rail
MC10H350PG	PDIP-16 (Pb-Free)	25 Unit / Rail

<sup>†</sup>For information on tape and reel specifications, including part orientation and tape sizes, please refer to our Tape and Reel Packaging Specifications Brochure, BRD8011/D.

# MC10H350

## PACKAGE DIMENSIONS

20 LEAD PLLC  
CASE 775-02  
ISSUE E

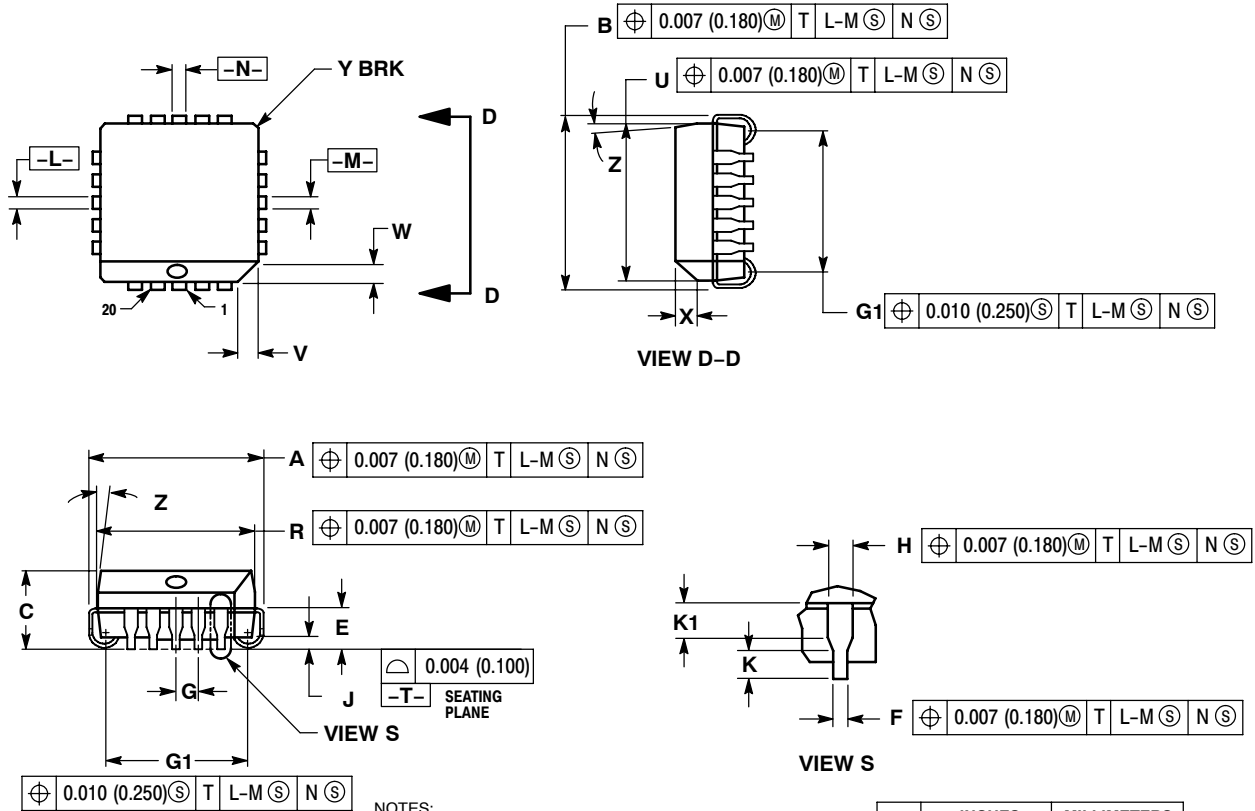

**NOTES:**

- DIMENSIONS AND TOLERANCING PER ANSI Y14.5M, 1982.
- DIMENSIONS IN INCHES.
- DATUMS -L-, -M-, AND -N- DETERMINED WHERE TOP OF LEAD SHOULDER EXITS PLASTIC BODY AT MOLD PARTING LINE.
- DIMENSION G1, TRUE POSITION TO BE MEASURED AT DATUM -T-, SEATING PLANE.
- DIMENSIONS R AND U DO NOT INCLUDE MOLD FLASH. ALLOWABLE MOLD FLASH IS 0.010 (0.250) PER SIDE.
- DIMENSIONS IN THE PACKAGE TOP MAY BE SMALLER THAN THE PACKAGE BOTTOM BY UP TO 0.012 (0.300). DIMENSIONS R AND U ARE DETERMINED AT THE OUTERMOST EXTREMES OF THE PLASTIC BODY EXCLUSIVE OF MOLD FLASH, TIE BAR BURRS, GATE BURRS AND INTERLEAD FLASH, BUT INCLUDING ANY MISMATCH BETWEEN THE TOP AND BOTTOM OF THE PLASTIC BODY.
- DIMENSION H DOES NOT INCLUDE DAMBAR PROTRUSION OR INTRUSION. THE DAMBAR PROTRUSION(S) SHALL NOT CAUSE THE H DIMENSION TO BE GREATER THAN 0.037 (0.940). THE DAMBAR INTRUSION(S) SHALL NOT CAUSE THE H DIMENSION TO BE SMALLER THAN 0.025 (0.635).

DIM	INCHES		MILLIMETERS	
	MIN	MAX	MIN	MAX
A	0.385	0.395	9.78	10.03
B	0.385	0.395	9.78	10.03
C	0.165	0.180	4.20	4.57
E	0.090	0.110	2.29	2.79
F	0.013	0.019	0.33	0.48
G	0.050 BSC		1.27 BSC	
H	0.026	0.032	0.66	0.81
J	0.020	---	0.51	---
K	0.025	---	0.64	---
R	0.350	0.356	8.89	9.04
U	0.350	0.356	8.89	9.04
V	0.042	0.048	1.07	1.21
W	0.042	0.048	1.07	1.21
X	0.042	0.056	1.07	1.42
Y	---	0.020	---	0.50
Z	2° 10°		2° 10°	
G1	0.310	0.330	7.88	8.38
K1	0.040	---	1.02	---

# MC10H350

## PACKAGE DIMENSIONS

### SOEIAJ-16 CASE 966-01 ISSUE A

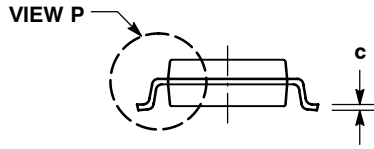

**NOTES:**

1. DIMENSIONING AND TOLERANCING PER ANSI Y14.5M, 1982.
2. CONTROLLING DIMENSION: MILLIMETER.
3. DIMENSIONS D AND E DO NOT INCLUDE MOLD FLASH OR PROTRUSIONS AND ARE MEASURED AT THE PARTING LINE. MOLD FLASH OR PROTRUSIONS SHALL NOT EXCEED 0.15 (0.006) PER SIDE.
4. TERMINAL NUMBERS ARE SHOWN FOR REFERENCE ONLY.
5. THE LEAD WIDTH DIMENSION (b) DOES NOT INCLUDE DAMBAR PROTRUSION. ALLOWABLE DAMBAR PROTRUSION SHALL BE 0.08 (0.003) TOTAL IN EXCESS OF THE LEAD WIDTH DIMENSION AT MAXIMUM MATERIAL CONDITION. DAMBAR CANNOT BE LOCATED ON THE LOWER RADIUS OR THE FOOT. MINIMUM SPACE BETWEEN PROTRUSIONS AND ADJACENT LEAD TO BE 0.46 (0.018).

DIM	MILLIMETERS		INCHES	
	MIN	MAX	MIN	MAX
A	---	2.05	---	0.081
A <sub>1</sub>	0.05	0.20	0.002	0.008
b	0.35	0.50	0.014	0.020
c	0.10	0.20	0.007	0.011
D	9.90	10.50	0.390	0.413
E	5.10	5.45	0.201	0.215
e	1.27 BSC			
HE	7.40	8.20	0.291	0.323
L	0.50	0.85	0.020	0.033
LE	1.10	1.50	0.043	0.059
M	0°	10°	0°	10°
Q <sub>1</sub>	0.70	0.90	0.028	0.035
Z	---	0.78	---	0.031

### CDIP-16 L SUFFIX CERAMIC DIP PACKAGE CASE 620A-01 ISSUE O

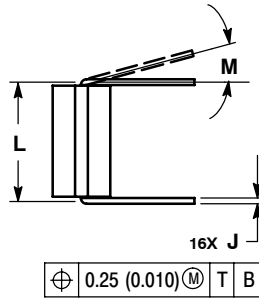
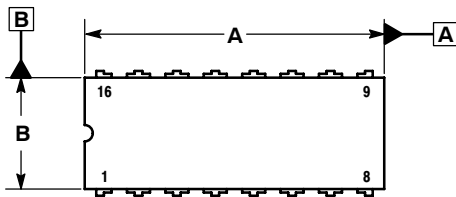

**NOTES:**

1. DIMENSIONING AND TOLERANCING PER ASME Y14.5M, 1994.
2. CONTROLLING DIMENSION: INCH.
3. DIMENSION L TO CENTER OF LEAD WHEN FORMED PARALLEL.
4. DIMENSION F MAY NARROW TO 0.76 (0.030) WHERE THE LEAD ENTERS THE CERAMIC BODY.
5. THIS DRAWING REPLACES OBSOLETE CASE OUTLINE 620-10.

DIM	INCHES		MILLIMETERS	
	MIN	MAX	MIN	MAX
A	0.750	0.785	19.05	19.93
B	0.240	0.295	6.10	7.49
C	---	0.200	---	5.08
D	0.015	0.020	0.39	0.50
E	0.050 BSC			
F	0.055	0.065	1.40	1.65
G	0.100 BSC			
H	0.008	0.015	0.21	0.38
K	0.125	0.170	3.18	4.31
L	0.300 BSC			
M	0°	15°	0°	15°
N	0.020	0.040	0.51	1.01

# MC10H350

## PACKAGE DIMENSIONS

### PDIP-16 P SUFFIX PLASTIC DIP PACKAGE CASE 648-08 ISSUE R

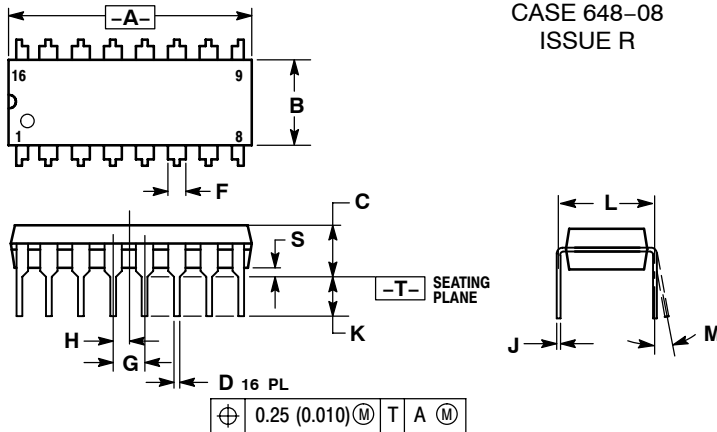

#### NOTES:

1. DIMENSIONING AND TOLERANCING PER ANSI Y14.5M, 1982.
2. CONTROLLING DIMENSION: INCH.
3. DIMENSION L TO CENTER OF LEADS WHEN FORMED PARALLEL.
4. DIMENSION B DOES NOT INCLUDE MOLD FLASH.
5. ROUNDED CORNERS OPTIONAL.

DIM	INCHES		MILLIMETERS	
	MIN	MAX	MIN	MAX
A	0.740	0.770	18.80	19.55
B	0.250	0.270	6.35	6.85
C	0.145	0.175	3.69	4.44
D	0.015	0.021	0.39	0.53
F	0.040	0.70	1.02	1.77
G	0.100 BSC		2.54 BSC	
H	0.050 BSC		1.27 BSC	
J	0.008	0.015	0.21	0.38
K	0.110	0.130	2.80	3.30
L	0.295	0.305	7.50	7.74
M	0°	10°	0°	10°
S	0.020	0.040	0.51	1.01

MECL 10K is a trademark of Motorola, Inc.

**ON Semiconductor** and  $\text{\textcircled{ON}}$  are registered trademarks of Semiconductor Components Industries, LLC (SCILLC). SCILLC reserves the right to make changes without further notice to any products herein. SCILLC makes no warranty, representation or guarantee regarding the suitability of its products for any particular purpose, nor does SCILLC assume any liability arising out of the application or use of any product or circuit, and specifically disclaims any and all liability, including without limitation special, consequential or incidental damages. "Typical" parameters which may be provided in SCILLC data sheets and/or specifications can and do vary in different applications and actual performance may vary over time. All operating parameters, including "Typicals" must be validated for each customer application by customer's technical experts. SCILLC does not convey any license under its patent rights nor the rights of others. SCILLC products are not designed, intended, or authorized for use as components in systems intended for surgical implant into the body, or other applications intended to support or sustain life, or for any other application in which the failure of the SCILLC product could create a situation where personal injury or death may occur. Should Buyer purchase or use SCILLC products for any such unintended or unauthorized application, Buyer shall indemnify and hold SCILLC and its officers, employees, subsidiaries, affiliates, and distributors harmless against all claims, costs, damages, and expenses, and reasonable attorney fees arising out of, directly or indirectly, any claim of personal injury or death associated with such unintended or unauthorized use, even if such claim alleges that SCILLC was negligent regarding the design or manufacture of the part. SCILLC is an Equal Opportunity/Affirmative Action Employer. This literature is subject to all applicable copyright laws and is not for resale in any manner.

#### PUBLICATION ORDERING INFORMATION

**LITERATURE FULFILLMENT:**  
Literature Distribution Center for ON Semiconductor  
P.O. Box 61312, Phoenix, Arizona 85082-1312 USA  
**Phone:** 480-829-7710 or 800-344-3860 Toll Free USA/Canada  
**Fax:** 480-829-7709 or 800-344-3867 Toll Free USA/Canada  
**Email:** orderlit@onsemi.com

**N. American Technical Support:** 800-282-9855 Toll Free  
USA/Canada

**Japan:** ON Semiconductor, Japan Customer Focus Center  
2-9-1 Kamimeguro, Meguro-ku, Tokyo, Japan 153-0051  
**Phone:** 81-3-5773-3850

**ON Semiconductor Website:** <http://onsemi.com>

**Order Literature:** <http://www.onsemi.com/litorder>

For additional information, please contact your local Sales Representative.

**MC10H350/D**