



FXLA102

Low-Voltage Dual-Supply 2-Bit Voltage Translator with Configurable Voltage Supplies and Signal Levels, 3-State Outputs, and Auto Direction Sensing

Features

- Bi-Directional Interface between Two Levels: from 1.1V to 3.6V
- Fully Configurable: Inputs and Outputs Track V_{CC} Level
- Non-Preferential Power-Up; Either V_{CC} May Be Powered Up First
- Outputs Switch to 3-State if Either V_{CC} is at GND
- Power-Off Protection
- Bus-Hold on Data Inputs Eliminates the Need for Pull-Up Resistors; Do Not Use Pull-Up Resistors on A or B Ports
- Control Input (/OE) Referenced to V_{CCA} Voltage
- Packaged in MicroPak™ 8 (1.6mm x 1.6mm)
- Direction Control Not Necessary
- 100Mbps Throughput when Translating Between 1.8V and 2.5V
- ESD Protection Exceeds:
 - 15kV HBM ((B Port I/O to GND) per JESD22-A114 & Mil Std 883e 3015.7)
 - 8kV HBM ((A Port I/O to GND) per JESD22-A114 & Mil Std 883e 3015.7)
 - 2kV CDM (per ESD STM 5.3)

Description

The FXLA102 is a configurable dual-voltage supply translator for both uni-directional and bi-directional voltage translation between two logic levels. The device allows translation between voltages as high as 3.6V to as low as 1.1V. The A port tracks the V_{CCA} level and the B port tracks the V_{CCB} level. This allows for bi-directional voltage translation over a variety of voltage levels: 1.2V, 1.5V, 1.8V, 2.5V, and 3.3V.

The device remains in three-state as long as either $V_{CC}=0V$, allowing either V_{CC} to be powered up first. Internal power-down control circuits place the device in 3-state if either V_{CC} is removed.

The /OE input, when HIGH, disables both the A and B ports by placing them in a 3-state condition. The /OE input is supplied by V_{CCA} .

The FXLA102 supports bi-directional translation without the need for a direction control pin. The two ports of the device have auto-direction sense capability. Either port may sense an input signal and transfer it as an output signal to the other port.

Ordering Information

| Part Number | Top Mark | Operating Temperature Range | Package | Packing Method |
|-------------|----------|-----------------------------|--|------------------------|
| FXLA102L8X | XF | -40 to 85°C | 8-Lead MicroPak™ 1.6mm x 1.6mm Package | 5K Units Tape and Reel |

Pin Configuration

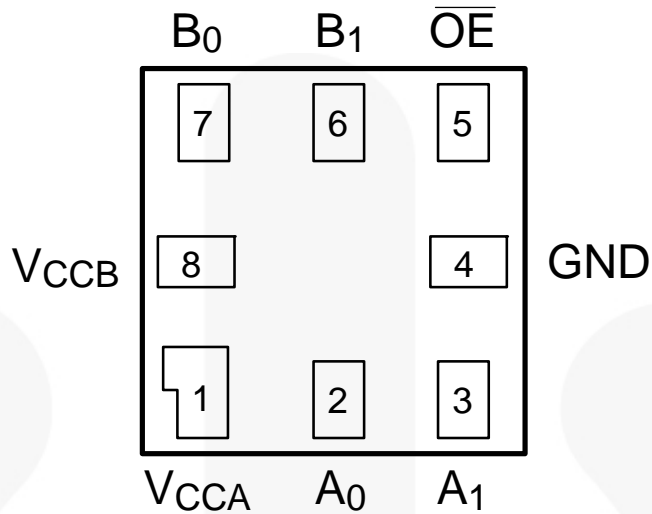

Figure 1. Pin Configuration (Top Through View)

Pin Definitions

| Pin # | Name | Description |
|-------|-----------------|--------------------------------|
| 1 | V_{CCA} | A-Side Power Supply |
| 2 | A_0 | A Side Input or 3-State Output |
| 3 | A_1 | A Side Input or 3-State Output |
| 4 | GND | Ground |
| 5 | \overline{OE} | Output Enable Input |
| 6 | B_1 | B Side Input or 3-State Output |
| 7 | B_0 | B Side Input or 3-State Output |
| 8 | V_{CCB} | B Side Power Supply |

Functional Diagram

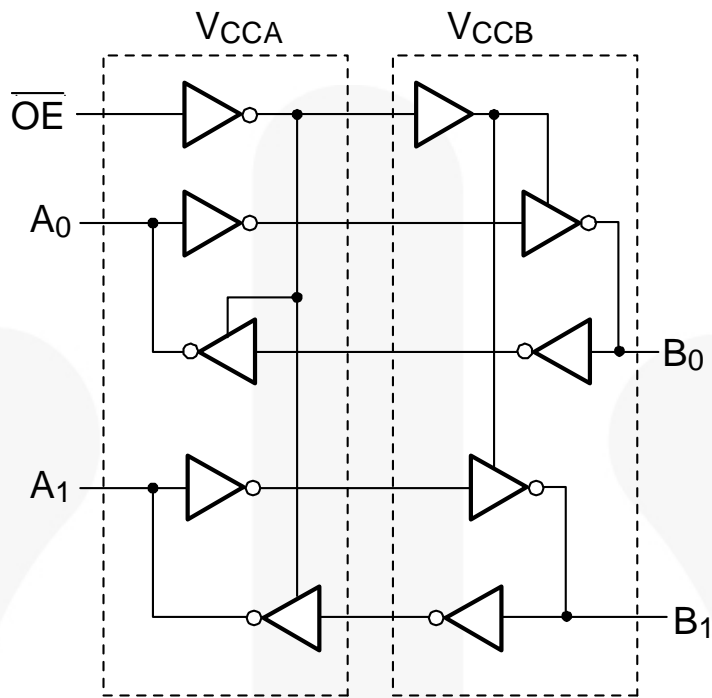

Figure 2. Functional Diagram

Function Table

| Control | Outputs |
|-----------------|------------------|
| \overline{OE} | |
| L | Normal Operation |
| H | 3-State |

H = HIGH Logic Level

L = LOW Logic Level

Absolute Maximum Ratings

Stresses exceeding the absolute maximum ratings may damage the device. The device may not function or be operable above the recommended operating conditions and stressing the parts to these levels is not recommended. In addition, extended exposure to stresses above the recommended operating conditions may affect device reliability. The absolute maximum ratings are stress ratings only.

| Symbol | Parameter | Conditions | Min. | Max. | Unit |
|-----------------|--|-------------------------|------|-----------------|------|
| V_{CC} | Supply Voltage | V_{CCA} | -0.5 | 4.6 | V |
| | | V_{CCB} | -0.5 | 4.6 | |
| V_I | DC Input Voltage | I/O Ports A and B | -0.5 | 4.6 | V |
| | | Control Input (/OE) | -0.5 | 4.6 | |
| V_O | Output Voltage ⁽²⁾ | Output 3-State | -0.5 | 4.6 | V |
| | | Output Active (A_n) | -0.5 | $V_{CCA} + 0.5$ | |
| | | Output Active (B_n) | -0.5 | $V_{CCB} + 0.5$ | |
| I_{IK} | DC Input Diode Current | $V_I < 0V$ | | -50 | mA |
| I_{OK} | DC Output Diode Current | $V_O < 0V$ | | -50 | mA |
| | | $V_O > V_{CC}$ | | +50 | |
| I_{OH}/I_{OL} | DC Output Source/Sink Current | | -50 | +50 | mA |
| I_{CC} | DC V_{CC} or Ground Current (per Supply Pin) | | | ±100 | mA |
| T_{STG} | Storage Temperature Range | | -65 | +150 | °C |
| P_D | Power Dissipation | | | 5 | mW |
| ESD | Human Body Model, JESD22-A114 | B Port I/O to GND | | 15 | kV |
| | | A Port I/O to GND | | 8 | |
| | Charged Device Model, JESD22-C101 | | | 2 | |

Notes:

- I_O absolute maximum ratings must be observed.
- All unused inputs and input/outputs must be held at V_{CCI} or GND.

Recommended Operating Conditions

The Recommended Operating Conditions table defines the conditions for actual device operation. Recommended operating conditions are specified to ensure optimal performance to the datasheet specifications. Fairchild does not recommend exceeding them or designing to Absolute Maximum Ratings.

| Symbol | Parameter | Conditions | Min. | Max. | Unit |
|---------------|--|----------------------------------|------|-----------|------|
| V_{CC} | Power Supply | Operating V_{CCA} or V_{CCB} | 1.1 | 3.6 | V |
| V_{IN} | Input Voltage | Ports A and B | 0 | 3.6 | V |
| | | Control Input (/OE) | 0 | V_{CCA} | V |
| | Dynamic Output Current I_{OH}/I_{OL} | $V_{CC} = 3.0V$ to $3.6V$ | | ±12 | mA |
| | | $V_{CC} = 2.3V$ to $2.7V$ | | ±8 | |
| | | $V_{CC} = 1.65V$ to $1.95V$ | | ±5 | |
| | | $V_{CC} = 1.40V$ to $1.65V$ | | ±3 | |
| | | $V_{CC} = 1.1V$ to $1.4V$ | | ±2 | |
| | Static Output Current | $V_{CC} = 1.1V$ to $3.6V$ | | ±4 | µA |
| T_A | Operating Temperature, Free Air | | -40 | +85 | °C |
| dt/dV | Maximum Input Edge Rate | $V_{CCA/B} = 1.1$ to $3.6V$ | | 10 | ns/V |
| Θ_{JA} | Thermal Resistance | | | 280 | °C/W |

Power-Up/Power-Down Sequence

FXL translators offer an advantage in that either V_{CC} may be powered up first. This benefit derives from the chip design. When either V_{CC} is at 0V, outputs are in a high-impedance state. The control input (/OE) is designed to track the V_{CCA} supply. A pull-up resistor tying /OE to V_{CCA} should be used to ensure that bus contention, excessive currents, or oscillations do not occur during power-up or power-down. The size of the pull-up resistor is based upon the current-sinking capability of the device driving the /OE pin.

The recommended power-up sequence is:

1. Apply power to the first V_{CC} .
2. Apply power to the second V_{CC} .
3. Drive the /OE input LOW to enable the device.

The recommended power-down sequence is:

1. Drive /OE input HIGH to disable the device.
2. Remove power from either V_{CC} .
3. Remove power from other V_{CC} .

Pull-Up/Pull-Down Resistors

Do not use pull-up or pull-down resistors. This device has bus-hold circuits: pull-up or pull-down resistors are not recommended because they interfere with the output state. The current through these resistors may exceed the hold drive, $I_{(HOLD)}$ and/or $I_{(OD)}$ bus-hold currents. The bus-hold feature eliminates the need for extra resistors.

DC Electrical Characteristics

T_A = -40 to 85°C.

| Symbol | Parameter | Conditions | V _{CCA} (V) | V _{CCB} (V) | Min. | Typ. | Max. | Units |
|----------------------|--|---|----------------------|----------------------|------------------------|------|----------------------|-------|
| V _{IHA} | High-Level Input Voltage | Data Inputs A _n Control Pin /OE | 2.70 to 3.60 | 1.10 to 3.60 | 2.00 | | | V |
| | | | 2.30 to 2.70 | | 1.60 | | | |
| | | | 1.65 to 2.30 | | .65xV _{CCA} | | | |
| | | | 1.40 to 1.65 | | .65xV _{CCA} | | | |
| | | | 1.10 to 1.40 | | .90xV _{CCA} | | | |
| V _{IHB} | High-Level Input Voltage | Data Inputs B _n | 2.70 to 3.60 | 1.10 to 3.60 | 2.00 | | | V |
| | | | 2.30 to 2.70 | | 1.60 | | | |
| | | | 1.65 to 2.30 | | .65xV _{CCB} | | | |
| | | | 1.40 to 1.65 | | .65xV _{CCB} | | | |
| | | | 1.10 to 1.40 | | .90xV _{CCB} | | | |
| V _{ILA} | Low-Level Input Voltage | Data Inputs A _n Control Pin /OE | 2.70 to 3.60 | 1.10 to 3.60 | | | .80 | V |
| | | | 2.30 to 2.70 | | | | .70 | |
| | | | 1.65 to 2.30 | | | | .35xV _{CCA} | |
| | | | 1.40 to 1.65 | | | | .35xV _{CCA} | |
| | | | 1.10 to 1.40 | | | | .10xV _{CCA} | |
| V _{ILB} | Low-Level Input Voltage | Data Inputs B _n | 2.70 to 3.60 | 1.10 to 3.60 | | | .80 | V |
| | | | 2.30 to 2.70 | | | | .70 | |
| | | | 1.65 to 2.30 | | | | .35xV _{CCB} | |
| | | | 1.40 to 1.65 | | | | .35xV _{CCB} | |
| | | | 1.10 to 1.40 | | | | .10xV _{CCB} | |
| V _{OHA} | High-Level Output Voltage ⁽³⁾ | I _{OH} = -4μA | 1.10 to 3.60 | 1.10 to 3.60 | V _{CCA} - .40 | | | V |
| V _{OHB} | | I _{OH} = -4μA | 1.10 to 3.60 | 1.10 to 3.60 | V _{CCB} - .40 | | | |
| V _{OLA} | Low-Level Output Voltage ⁽³⁾ | I _{OL} = 4μA | 1.10 to 3.60 | 1.10 to 3.60 | | | .4 | V |
| V _{OLB} | | I _{OL} = 4μA | 1.10 to 3.60 | 1.10 to 3.60 | | | .4 | |
| I _{I(HOLD)} | Bus-Hold Input Minimum Drive Current | V _{IN} = 0.80V | 3.00 | 3.00 | 75.0 | | | μA |
| | | V _{IN} = 2.00V | 3.00 | 3.00 | -75.0 | | | |
| | | V _{IN} = 0.70V | 2.30 | 2.30 | 45.0 | | | |
| | | V _{IN} = 1.60V | 2.30 | 2.30 | -45.0 | | | |
| | | V _{IN} = 0.57V | 1.65 | 1.65 | 25.0 | | | |
| | | V _{IN} = 1.07V | 1.65 | 1.65 | -25.0 | | | |
| | | V _{IN} = 0.49V | 1.40 | 1.40 | 11.0 | | | |
| | | V _{IN} = 0.91V | 1.40 | 1.40 | -11.0 | | | |
| | | V _{IN} = 0.11V | 1.10 | 1.10 | | 4.0 | | |
| | | V _{IN} = 0.99V | 1.10 | 1.10 | | -4.0 | | |

Continued on following page...

DC Electrical Characteristics (Continued)

T_A = -40 to 85°C.

| Symbol | Parameter | Conditions | V _{CCA} (V) | V _{CCB} (V) | Min. | Max. | Units |
|---------------------|--|--|----------------------|----------------------|---------|-------|-------|
| I _{I(ODH)} | Bus-Hold Input Overdrive High Current ⁽⁴⁾ | Data Inputs A _n , B _n | 3.60 | 3.60 | 450.00 | | μA |
| | | | 2.70 | 2.70 | 300.00 | | |
| | | | 1.95 | 1.95 | 200.00 | | |
| | | | 1.60 | 1.60 | 120.00 | | |
| | | | 1.40 | 1.40 | 80.00 | | |
| I _{I(ODL)} | Bus-Hold Input Overdrive Low Current ⁽⁵⁾ | Data Inputs A _n , B _n | 3.60 | 3.60 | -450.00 | | μA |
| | | | 2.70 | 2.70 | -300.00 | | |
| | | | 1.95 | 1.95 | -200.00 | | |
| | | | 1.60 | 1.60 | -120.00 | | |
| | | | 1.40 | 1.40 | -80.00 | | |
| I _I | Input Leakage Current | Control Inputs /OE, V _I =V _{CCA} or GND | 1.10 to 3.60 | 3.60 | | ±1.0 | μA |
| I _{OFF} | Power-Off Leakage Current | A _n Port V _O =0V to 3.6V | 0 | 3.6 | | ±2.0 | μA |
| | | B _n Port V _O =0V to 3.6V | 3.60 | 0 | | ±2.0 | |
| I _{OZ} | 3-State Output Leakage | Data Outputs A _n , B _n V _O =0V or 3.6V, /OE=V _{IH} | 3.60 | 3.60 | | ±5.0 | μA |
| | | Data Outputs Data Outputs A _n V _O =0V or 3.6V, /OE=GND | 3.60 | 0 | | ±5.0 | |
| | | Data Outputs B _n V _O =0V or 3.6V, /OE=GND | 0 | 3.60 | | ±5.0 | |
| I _{CCA/B} | Quiescent Supply Current ^(6, 7) | V _I =V _{CCI} or GND; I _O =0, /OE=GND | 1.10 to 3.60 | 1.10 to 3.60 | | 10.0 | μA |
| I _{CCZ} | | V _I =V _{CCI} or GND; I _O =0, /OE=V _{IH} | 1.10 to 3.60 | 1.10 to 3.60 | | 10.0 | μA |
| I _{CCA} | Quiescent Supply Current | V _I =V _{CCB} or GND; I _O =0 B-to-A Direction, /OE=GND | 0 | 1.10 to 3.60 | | -10.0 | μA |
| | | | 1.10 to 3.60 | 0 | | 10.0 | |
| I _{CCB} | Quiescent Supply Current | V _I =V _{CCA} or GND; I _O =0, A-to-B Direction, /OE=GND | 1.10 to 3.60 | 0 | | -10.0 | μA |
| | | | 0 | 1.10 to 3.60 | | 10.0 | |

Notes:

3. This is the output voltage for static conditions. Dynamic drive specifications are given in the Dynamic Output Electrical Characteristics table.
4. An external drive must source at least the specified current to switch LOW-to-HIGH.
5. An external drive must source at least the specified current to switch HIGH-to-LOW.
6. V_{CCI} is the V_{CC} associated with the input side.
7. Reflects current per supply, V_{CCA} or V_{CCB}.

Dynamic Output Electrical Characteristic

A Port (A_n)

Output Load: C_L=15pF, R_L ≥ MΩ (C_{I/O}=4pF), T_A=-40 to 85°C

| Symbol | Parameter | V _{CCA} =3.0V to 3.6V | | V _{CCA} =2.3V to 2.7V | | V _{CCA} =1.65V to 1.95V | | V _{CCA} =1.4V to 1.6V | | V _{CCA} =1.1V to 1.3V | Units |
|-------------------|--|-----------------------------------|------|-----------------------------------|------|-------------------------------------|------|-----------------------------------|------|-----------------------------------|-------|
| | | Typ. | Max. | Typ. | Max. | Typ. | Max. | Typ. | Max. | Typ. | |
| t _{rise} | Output Rise Time A Port ⁽⁹⁾ | | 3.0 | | 3.5 | | 4.0 | | 5.0 | 7.5 | ns |
| t _{fall} | Output Fall Time A Port ⁽¹⁰⁾ | | 3.0 | | 3.5 | | 4.0 | | 5.0 | 7.5 | ns |
| I _{OHD} | Dynamic Output Current High ⁽⁹⁾ | -11.4 | | -7.5 | | -4.7 | | -3.2 | | -1.7 | mA |
| I _{OLD} | Dynamic Output Current Low ⁽¹⁰⁾ | +11.4 | | +7.5 | | +4.7 | | +3.2 | | +1.7 | mA |

B Port (B_n)

Output Load: C_L=15pF, R_L ≥ MΩ (C_{I/O}=5pF), T_A=-40 to 85°C

| Symbol | Parameter | V _{CCB} =3.0V to 3.6V | | V _{CCB} =2.3V to 2.7V | | V _{CCB} =1.65V to 1.95V | | V _{CCB} =1.4V to 1.6V | | V _{CCB} =1.1V to 1.3V | Units |
|-------------------|--|-----------------------------------|------|-----------------------------------|------|-------------------------------------|------|-----------------------------------|------|-----------------------------------|-------|
| | | Typ. | Max. | Typ. | Max. | Typ. | Max. | Typ. | Max. | Typ. | |
| t _{rise} | Output Rise Time B Port ⁽⁹⁾ | | 3.0 | | 3.5 | | 4.0 | | 5.0 | 7.5 | ns |
| t _{fall} | Output Fall Time B Port ⁽¹⁰⁾ | | 3.0 | | 3.5 | | 4.0 | | 5.0 | 7.5 | ns |
| I _{OHD} | Dynamic Output Current High ⁽⁹⁾ | -12.0 | | -7.9 | | -5.0 | | -3.4 | | -1.8 | mA |
| I _{OLD} | Dynamic Output Current Low ⁽¹⁰⁾ | +12.0 | | +7.9 | | +5.0 | | +3.4 | | +1.8 | mA |

Notes:

8. Dynamic output characteristics are guaranteed, but not tested.
9. See Figure 7.
10. See Figure 8.

AC Characteristics

$V_{CCA} = 3.0V$ to $3.6V$, $T_A = -40$ to $85^\circ C$

| Symbol | Parameter | $V_{CCB}=3.0V$ to $3.6V$ | | $V_{CCB}=2.3V$ to $2.7V$ | | $V_{CCB}=1.65V$ to $1.95V$ | | $V_{CCB}=1.4V$ to $1.6V$ | | $V_{CCB}=1.1V$ to $1.3V$ | Units |
|--------------------|-----------------------------------|-----------------------------|------|-----------------------------|------|-------------------------------|------|-----------------------------|------|-----------------------------|---------|
| | | Min. | Max. | Min. | Max. | Min. | Max. | Min. | Max. | Typ. | |
| t_{PLH}, t_{PHL} | A to B | 0.2 | 3.5 | 0.3 | 3.9 | 0.5 | 5.4 | 0.6 | 6.8 | 10.0 | ns |
| | B to A | 0.2 | 3.5 | 0.2 | 3.8 | 0.3 | 5.0 | 0.5 | 6.0 | 7.0 | ns |
| t_{PZL}, t_{PZH} | /OE to A, /OE to B | | 1.7 | | 1.7 | | 1.7 | | 1.7 | 1.7 | μs |
| t_{SKEW} | A Port, B Port ⁽¹¹⁾ | | 0.5 | | 0.5 | | 0.5 | | 1.0 | 1.0 | ns |

$V_{CCA} = 2.3V$ to $2.7V$, $T_A = -40$ to $85^\circ C$

| Symbol | Parameter | $V_{CCB}=3.0V$ to $3.6V$ | | $V_{CCB}=2.3V$ to $2.7V$ | | $V_{CCB}=1.65V$ to $1.95V$ | | $V_{CCB}=1.4V$ to $1.6V$ | | $V_{CCB}=1.1V$ to $1.3V$ | Units |
|--------------------|-----------------------------------|-----------------------------|------|-----------------------------|------|-------------------------------|------|-----------------------------|------|-----------------------------|---------|
| | | Min. | Max. | Min. | Max. | Min. | Max. | Min. | Max. | Typ. | |
| t_{PLH}, t_{PHL} | A to B | 0.2 | 3.8 | 0.4 | 4.2 | 0.5 | 5.6 | 0.8 | 6.9 | 10.5 | ns |
| | B to A | 0.3 | 3.9 | 0.4 | 4.2 | 0.5 | 5.5 | 0.5 | 6.5 | 7.0 | ns |
| t_{PZL}, t_{PZH} | /OE to A, /OE to B | | 1.7 | | 1.7 | | 1.7 | | 1.7 | 1.7 | μs |
| t_{SKEW} | A Port, B Port ⁽¹¹⁾ | | 0.5 | | 0.5 | | 0.5 | | 1.0 | 1.0 | ns |

$V_{CCA} = 1.65V$ to $1.95V$, $T_A = -40$ to $85^\circ C$

| Symbol | Parameter | $V_{CCB}=3.0V$ to $3.6V$ | | $V_{CCB}=2.3V$ to $2.7V$ | | $V_{CCB}=1.65V$ to $1.95V$ | | $V_{CCB}=1.4V$ to $1.6V$ | | $V_{CCB}=1.1V$ to $1.3V$ | Units |
|--------------------|-----------------------------------|-----------------------------|------|-----------------------------|------|-------------------------------|------|-----------------------------|------|-----------------------------|---------|
| | | Min. | Max. | Min. | Max. | Min. | Max. | Min. | Max. | Typ. | |
| t_{PLH}, t_{PHL} | A to B | 0.3 | 5.0 | 0.5 | 5.5 | 0.8 | 6.7 | 0.9 | 7.5 | 11.0 | ns |
| | B to A | 0.5 | 5.4 | 0.5 | 5.6 | 0.8 | 6.7 | 1.0 | 7.0 | 7.0 | ns |
| t_{PZL}, t_{PZH} | /OE to A, /OE to B | | 1.7 | | 1.7 | | 1.7 | | 1.7 | 1.7 | μs |
| t_{SKEW} | A Port, B Port ⁽¹¹⁾ | | 0.5 | | 0.5 | | 0.5 | | 1.0 | 1.0 | ns |

Note:

- Skew is the variation of propagation delay between output signals and applies only to output signals on the same port (A_n or B_n) and switching with the same polarity (LOW-to-HIGH or HIGH-to-LOW) (see Figure 10). Skew is guaranteed, but not tested.

AC Characteristics (Continued)

$V_{CCA} = 1.4V$ to $1.6V$, $T_A = -40$ to $85^\circ C$

| Symbol | Parameter | $V_{CCB}=3.0V$ to $3.6V$ | | $V_{CCB}=2.3V$ to $2.7V$ | | $V_{CCB}=1.65V$ to $1.95V$ | | $V_{CCB}=1.4V$ to $1.6V$ | | $V_{CCB}=1.1V$ to $1.3V$ | Units |
|--------------------|-----------------------------------|-----------------------------|------|-----------------------------|------|-------------------------------|------|-----------------------------|------|-----------------------------|---------|
| | | Min. | Max. | Min. | Max. | Min. | Max. | Min. | Max. | Typ. | |
| t_{PLH}, t_{PHL} | A to B | 0.5 | 6.0 | 0.5 | 6.5 | 1.0 | 7.0 | 1.0 | 8.5 | 11.5 | ns |
| | B to A | 0.6 | 6.8 | 0.8 | 6.9 | 0.9 | 7.5 | 1.0 | 8.5 | 9.0 | ns |
| t_{PZL}, t_{PZH} | /OE to A, /OE to B | | 1.7 | | 1.7 | | 1.7 | | 1.7 | 1.7 | μs |
| t_{SKEW} | A Port, B Port ⁽¹²⁾ | | 1.0 | | 1.0 | | 1.0 | | 1.0 | 1.0 | ns |

$V_{CCA} = 1.1V$ to $1.3V$, $T_A = -40$ to $85^\circ C$

| Symbol | Parameter | $V_{CCB}=3.0V$ to $3.6V$ | $V_{CCB}=2.3V$ to $2.7V$ | $V_{CCB}=1.65V$ to $1.95V$ | $V_{CCB}=1.4V$ to $1.6V$ | $V_{CCB}=1.1V$ to $1.3V$ | Units |
|--------------------|--------------------------------|-----------------------------|-----------------------------|-------------------------------|-----------------------------|-----------------------------|---------|
| | | Typ. | Typ. | Typ. | Typ. | Typ. | |
| t_{PLH}, t_{PHL} | A to B | 7.1 | 6.5 | 7.0 | 7.1 | 13.5 | ns |
| | B to A | 10.3 | 10.5 | 10.8 | 11.3 | 13.5 | ns |
| t_{PZL}, t_{PZH} | /OE to A, /OE to B | 1.7 | 1.7 | 1.7 | 1.7 | 1.7 | μs |
| t_{SKEW} | A Port, B Port ⁽¹²⁾ | 1.0 | 1.0 | 1.0 | 1.0 | 1.0 | ns |

Note:

12. Skew is the variation of propagation delay between output signals and applies only to output signals on the same port (A_n or B_n) and switching with the same polarity (LOW-to-HIGH or HIGH-to-LOW) (see Figure 10). Skew is guaranteed, but not tested.

Maximum Data Rate

$T_A = -40$ to 85°C .

| V_{CCA} | $V_{CCB}=3.0\text{V}$ to 3.6V | $V_{CCB}=2.3\text{V}$ to 2.7V | $V_{CCB}=1.65\text{V}$ to 1.95V | $V_{CCB}=1.4\text{V}$ to 1.6V | $V_{CCB}=1.1\text{V}$ to 1.3V | Units |
|--|---|---|---|---|---|-------|
| | Min. | Min. | Min. | Min. | Typ. | |
| $V_{CCA}=3.00\text{V}$ to 3.60V | 140 | 120 | 100 | 80 | 40 | Mbps |
| $V_{CCA}=2.30\text{V}$ to 2.70V | 120 | 120 | 100 | 80 | 40 | Mbps |
| $V_{CCA}=1.65\text{V}$ to 1.95V | 100 | 100 | 80 | 60 | 40 | Mbps |
| $V_{CCA}=1.40\text{V}$ to 1.60V | 80 | 80 | 60 | 60 | 40 | Mbps |
| $V_{CCA}=1.10\text{V}$ to 1.30V | Typ. | Typ. | Typ. | Typ. | Typ. | |
| | 40 | 40 | 40 | 40 | 40 | Mbps |

Notes:

13. Maximum data rate is guaranteed, but not tested.
14. Maximum data rate is specified in megabits per second (see Figure 9). It is equivalent to two times the F-toggle frequency, specified in megahertz. For example, 100Mbps is equivalent to 50MHz.

Capacitance

| Symbol | Parameter | Conditions | $T_A = +25^\circ\text{C}$ Typical | Units | |
|-----------|-------------------------------------|--|--------------------------------------|-------|----|
| C_{IN} | Input Capacitance Control Pin (/OE) | $V_{CCA}=V_{CCB}=\text{GND}$ | 3 | pF | |
| $C_{I/O}$ | Input / Output Capacitance | $V_{CCA}=V_{CCB}=3.3\text{V}$, /OE= V_{CCA} | A_n | 4 | pF |
| | | | B_n | 5 | |
| C_{pd} | Power Dissipation Capacitance | $V_{CCA}=V_{CCB}=3.3\text{V}$, $V_I=0\text{V}$ or V_{CC} , $f=10\text{MHz}$ | 25 | pF | |

I/O Architecture Benefit

The FXLA102 I/O architecture benefits the end user, beyond level translation, in the following three ways:

Auto Direction without an external direction pin.

Drive Capacitive Loads. Automatically shifts to a higher current drive mode only during “Dynamic Mode” or HL / LH transitions.

Lower Power Consumption. Automatically shifts to low-power mode during “Static Mode” (no transitions), lowering power consumption.

The FXLA102 does not require a direction pin. Instead, the I/O architecture detects input transitions on both side and automatically transfers the data to the corresponding output. For example, for a given channel, if both A and B side are at a static LOW, the direction has been established as $A \rightarrow B$, and a LH transition occurs on the B port; the FXLA102 internal I/O architecture automatically changes direction from $A \rightarrow B$ to $B \rightarrow A$.

During HL / LH transitions, or “Dynamic Mode,” a strong output driver drives the output channel in parallel with a weak output driver. After a typical delay of approximately 10ns – 50ns, the strong driver is turned off, leaving the weak driver enabled for holding the logic state of the channel. This weak driver is called the “bus hold.” “Static Mode” is when only the bus hold drives the channel. The

bus hold can be over ridden in the event of a direction change. The strong driver allows the FXLA102 to quickly charge and discharge capacitive transmission lines during dynamic mode. Static mode conserves power, where I_{CC} is typically $< 5\mu A$.

Bus Hold Minimum Drive Current

Specifies the minimum amount of current the bus hold driver can source/sink. The bus hold minimum drive current (I_{HOLD}) is V_{CC} dependent and guaranteed in the DC Electrical tables. The intent is to maintain a valid output state in a static mode, but that can be overridden when an input data transition occurs.

Bus Hold Input Overdrive Drive Current

Specifies the minimum amount of current required (by an external device) to overdrive the bus hold in the event of a direction change. The bus hold overdrive (I_{ODH} , I_{ODL}) is V_{CC} dependent and guaranteed in the DC Electrical tables.

Dynamic Output Current

The strength of the output driver during LH / HL transitions is *referenced on page 8, Dynamic Output Electrical Characteristics, I_{OHD} , and I_{OLD} .*

Test Diagrams

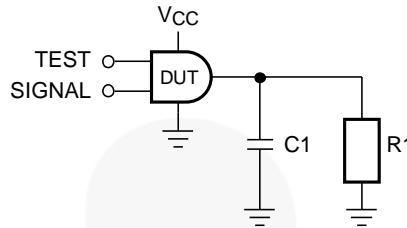

Figure 3. Test Circuit

Table 1. AC Test Conditions

| Test | Input Signal | Output Enable Control |
|-----------------------|--------------|-----------------------|
| t_{PLH} , t_{PHL} | Data Pulses | 0V |
| t_{PZL} | 0V | HIGH to LOW Switch |
| t_{PZH} | V_{CCI} | HIGH to LOW Switch |

Table 2. AC Load

| V_{CCO} | C1 | R1 |
|------------------|------|-------------|
| $1.2V \pm 0.1V$ | 15pF | 1M Ω |
| $1.5V \pm 0.1V$ | 15pF | 1M Ω |
| $1.8V \pm 0.15V$ | 15pF | 1M Ω |
| $2.5V \pm 0.2V$ | 15pF | 1M Ω |
| $3.3V \pm 0.3V$ | 15pF | 1M Ω |

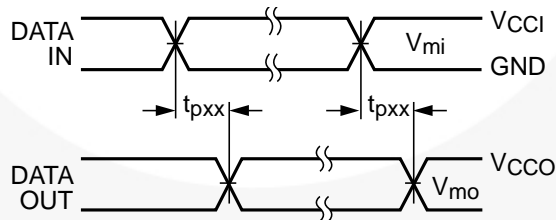

Figure 4. Waveform for Inverting and Non-Inverting Functions

Notes:

15. Input $t_R = t_F = 2.0ns$, 10% to 90%.
16. Input $t_R = t_F = 2.5ns$, 10% to 90%, at $V_I = 3.0V$ to $3.6V$ only.

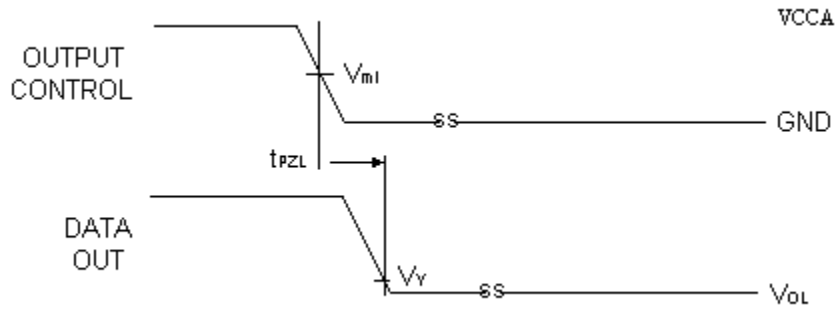

Figure 5. 3-State Output Low Enable Time

Notes:

- 17. Input $t_R = t_F = 2.0\text{ns}$, 10% to 90%.
- 18. Input $t_R = t_F = 2.5\text{ns}$, 10% to 90%, at $V_I = 3.0\text{V}$ to 3.6V only.

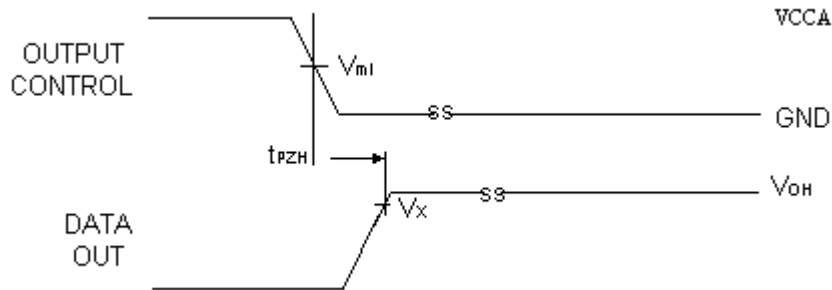

Figure 6. 3-State Output High Enable Time

Notes:

- 19. Input $t_R = t_F = 2.0\text{ns}$, 10% to 90%.
- 20. Input $t_R = t_F = 2.5\text{ns}$, 10% to 90%, at $V_I = 3.0\text{V}$ to 3.6V only.

Table 3. Test Measure Points

| Symbol | V_{CC} |
|-----------------|----------------------|
| $V_{MI}^{(21)}$ | $V_{CCi} / 2$ |
| V_{MO} | $V_{CCo} / 2$ |
| V_X | $0.9 \times V_{CCo}$ |
| V_Y | $0.1 \times V_{CCo}$ |

Note:

- 21. $V_{CCI} = V_{CCA}$ for control pin /OE or $V_{MI} = (V_{CCA} / 2)$.

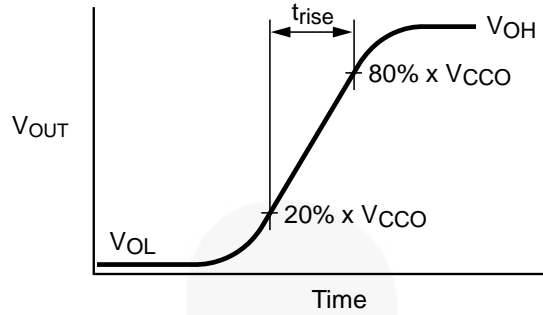

$$I_{OHD} \approx (C_L + C_{I/O}) \times \frac{\Delta V_{OUT}}{\Delta t} = (C_L + C_{I/O}) \times \frac{(20\% - 80\%) \cdot V_{CCO}}{t_{RISE}}$$

Figure 7. Active Output Rise Time and Dynamic Output Current High

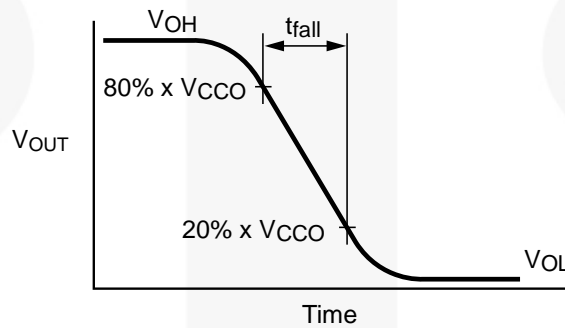

$$I_{OLD} \approx (C_L + C_{I/O}) \times \frac{\Delta V_{OUT}}{\Delta t} = (C_L + C_{I/O}) \times \frac{(80\% - 20\%) \cdot V_{CCO}}{t_{FALL}}$$

Figure 8. Active Output Fall Time and Dynamic Output Current Low

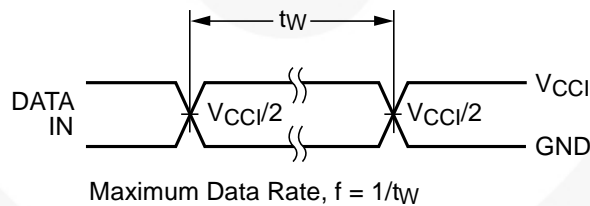

Figure 9. Maximum Data Rate

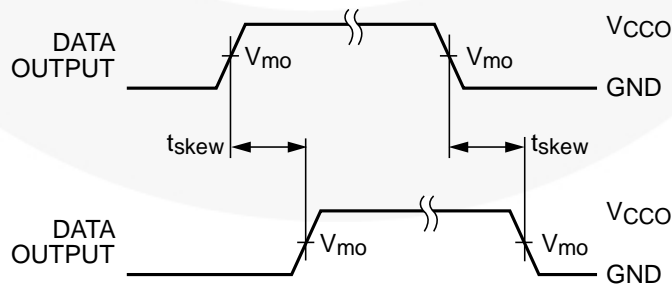
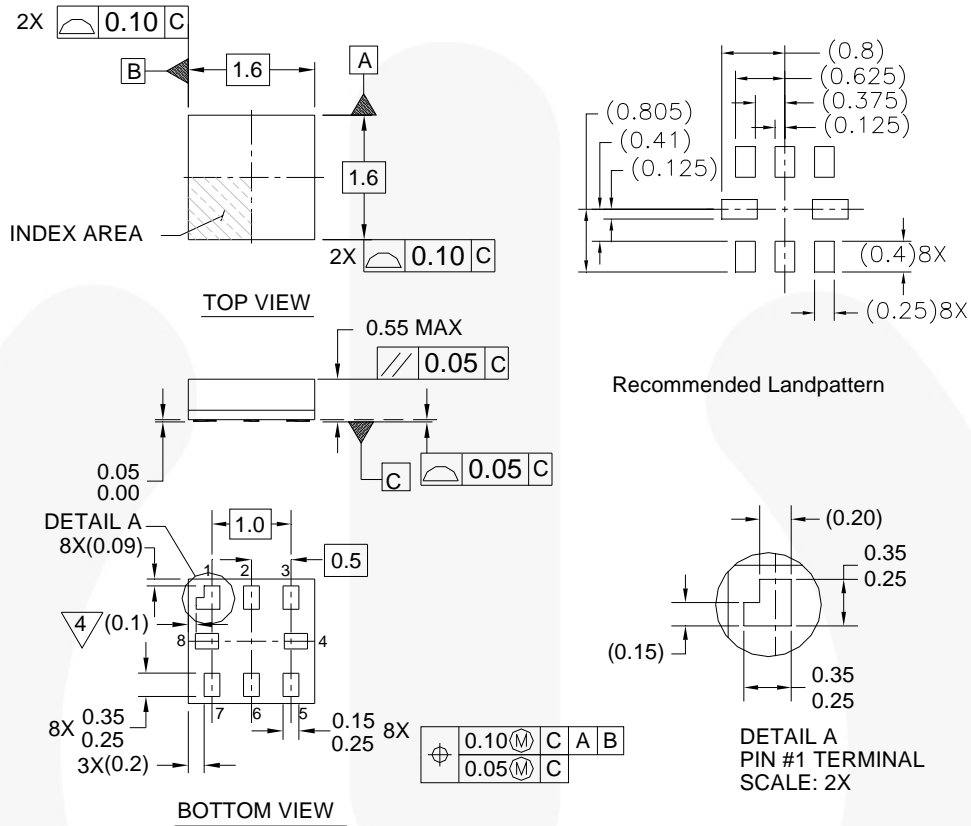

Figure 10. Output Skew Time

Note:

22. $t_{SKEW} = (t_{pHLmax} - t_{pHLmin})$ or $(t_{pLHmax} - t_{pLHmin})$

Physical Dimensions



Notes:

1. PACKAGE CONFORMS TO JEDEC MO-255 VARIATION UAAD
2. DIMENSIONS ARE IN MILLIMETERS
3. DRAWING CONFORMS TO ASME Y.14M-1994
4. PIN 1 FLAG, END OF PACKAGE OFFSET
5. DRAWING FILE NAME: MKT-MAC08AREV4

MAC08AREV4

Figure 11. 8-Lead, MicroPak™, 1.6mm Wide

Package drawings are provided as a service to customers considering Fairchild components. Drawings may change in any manner without notice. Please note the revision and/or date on the drawing and contact a Fairchild Semiconductor representative to verify or obtain the most recent revision. Package specifications do not expand the terms of Fairchild's worldwide terms and conditions, specifically the warranty therein, which covers Fairchild products.

Always visit Fairchild Semiconductor's online packaging area for the most recent package drawings:
<http://www.fairchildsemi.com/packaging/>





Tape and Reel Specifications

Please visit Fairchild Semiconductor's online packaging area for the most recent tape and reel specifications:
http://www.fairchildsemi.com/products/logic/pdf/micropak_tr.pdf/



TRADEMARKS

The following includes registered and unregistered trademarks and service marks, owned by Fairchild Semiconductor and/or its global subsidiaries, and is not intended to be an exhaustive list of all such trademarks.

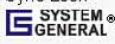
- | | | | |
|---|---|---|---|
| AccuPower™ | F-PFS™ | Power-SPM™ | The Power Franchise® |
| Auto-SPM™ | FRFET® | PowerTrench® | The Right Technology for Your Success™ |
| AX-CAP™ | Global Power Resource™ | PowerXS™ | the power franchise |
| Build it Now™ | Green FPST™ | Programmable Active Droop™ | TinyBoost™ |
| CorePLUS™ | Green FPST™ e-Series™ | QFET® | TinyBuck™ |
| CorePOWER™ | Gmax™ | QS™ | TinyCalc™ |
| CROSSVOLT™ | GTO™ | Quiet Series™ | TinyLogic® |
| CTL™ | IntelliMAX™ | RapidConfigure™ | TINYOPTO™ |
| Current Transfer Logic™ | ISOPLANAR™ |  | TinyPower™ |
| DEUXPEED® | MegaBuck™ | Saving our world, 1mW/W/kW at a time™ | TinyPWM™ |
| Dual Cool™ | MICROCOUPLER™ | SignalWise™ | TinyWire™ |
| EcoSPARK® | MicroFET™ | SmartMax™ | TriFault Detect™ |
| EfficientMax™ | MicroPak™ | SMART START™ | TRUECURRENT® |
| ESBC™ | MicroPak2™ | SPM® | µSerDes™ |
|  | MillerDrive™ | STEALTH™ |  |
| Fairchild® | MotionMax™ | SuperFET® | UHC |
| Fairchild Semiconductor® | Motion-SPM™ | SuperSOT™-3 | Ultra FRFET™ |
| FACT Quiet Series™ | mWSaver™ | SuperSOT™-8 | UniFET™ |
| FACT® | OptoHIT™ | SuperSOT™-8 | VCX™ |
| FAST® | OPTOLOGIC® | SupreMOS® | VisualMax™ |
| FastvCore™ | OPTOPLANAR® | SyncFET™ | XS™ |
| FETBench™ |  | Sync-Lock™ | |
| FlashWriter® | PDP-SPM™ |  | |
| FPS™ | | | |

* Trademarks of System General Corporation, used under license by Fairchild Semiconductor.

DISCLAIMER

FAIRCHILD SEMICONDUCTOR RESERVES THE RIGHT TO MAKE CHANGES WITHOUT FURTHER NOTICE TO ANY PRODUCTS HEREIN TO IMPROVE RELIABILITY, FUNCTION, OR DESIGN. FAIRCHILD DOES NOT ASSUME ANY LIABILITY ARISING OUT OF THE APPLICATION OR USE OF ANY PRODUCT OR CIRCUIT DESCRIBED HEREIN; NEITHER DOES IT CONVEY ANY LICENSE UNDER ITS PATENT RIGHTS, NOR THE RIGHTS OF OTHERS. THESE SPECIFICATIONS DO NOT EXPAND THE TERMS OF FAIRCHILD'S WORLDWIDE TERMS AND CONDITIONS, SPECIFICALLY THE WARRANTY THEREIN, WHICH COVERS THESE PRODUCTS.

LIFE SUPPORT POLICY

FAIRCHILD'S PRODUCTS ARE NOT AUTHORIZED FOR USE AS CRITICAL COMPONENTS IN LIFE SUPPORT DEVICES OR SYSTEMS WITHOUT THE EXPRESS WRITTEN APPROVAL OF FAIRCHILD SEMICONDUCTOR CORPORATION.

As used herein:

- Life support devices or systems are devices or systems which, (a) are intended for surgical implant into the body or (b) support or sustain life, and (c) whose failure to perform when properly used in accordance with instructions for use provided in the labeling, can be reasonably expected to result in a significant injury of the user.
- A critical component in any component of a life support, device, or system whose failure to perform can be reasonably expected to cause the failure of the life support device or system, or to affect its safety or effectiveness.

ANTI-COUNTERFEITING POLICY

Fairchild Semiconductor Corporation's Anti-Counterfeiting Policy. Fairchild's Anti-Counterfeiting Policy is also stated on our external website, www.fairchildsemi.com, under Sales Support.

Counterfeiting of semiconductor parts is a growing problem in the industry. All manufacturers of semiconductor products are experiencing counterfeiting of their parts. Customers who inadvertently purchase counterfeit parts experience many problems such as loss of brand reputation, substandard performance, failed applications, and increased cost of production and manufacturing delays. Fairchild is taking strong measures to protect ourselves and our customers from the proliferation of counterfeit parts. Fairchild strongly encourages customers to purchase Fairchild parts either directly from Fairchild or from Authorized Fairchild Distributors who are listed by country on our web page cited above. Products customers buy either from Fairchild directly or from Authorized Fairchild Distributors are genuine parts, have full traceability, meet Fairchild's quality standards for handling and storage and provide access to Fairchild's full range of up-to-date technical and product information. Fairchild and our Authorized Distributors will stand behind all warranties and will appropriately address any warranty issues that may arise. Fairchild will not provide any warranty coverage or other assistance for parts bought from Unauthorized Sources. Fairchild is committed to combat this global problem and encourage our customers to do their part in stopping this practice by buying direct or from authorized distributors.

PRODUCT STATUS DEFINITIONS

Definition of Terms

| Datasheet Identification | Product Status | Definition |
|--------------------------|-----------------------|---|
| Advance Information | Formative / In Design | Datasheet contains the design specifications for product development. Specifications may change in any manner without notice. |
| Preliminary | First Production | Datasheet contains preliminary data; supplementary data will be published at a later date. Fairchild Semiconductor reserves the right to make changes at any time without notice to improve design. |
| No Identification Needed | Full Production | Datasheet contains final specifications. Fairchild Semiconductor reserves the right to make changes at any time without notice to improve the design. |
| Obsolete | Not In Production | Datasheet contains specifications on a product that is discontinued by Fairchild Semiconductor. The datasheet is for reference information only. |

Rev. I53