

DM74ALS251

3-STATE 1-of-8 Line Data Selector/Multiplexer

General Description

This Data Selector/Multiplexer contains full on-chip decoding to select one-of-eight data sources as a result of a unique three-bit binary code at the Select inputs. Two complementary outputs provide both inverting and non-inverting buffer operation. An Output Control input is provided which, when at the high level, places both outputs in the high impedance OFF-State. In order to prevent bus access conflicts, output disable times are shorter than output enable times. The Select input buffers incorporate internal overlap features to ensure that select input changes do not cause invalid output transients.

Features

- Advanced oxide-isolated, ion-implanted Schottky TTL process
- Switching performance is guaranteed over full temperature and V_{CC} supply range
- Pin and functional compatible with LS family counterpart
- Improved output transient handling capability
- Output control circuitry incorporates power-up 3-STATE feature

Ordering Code:

Order Number	Package Number	Package Description
DM74ALS251M	M16A	16-Lead Small Outline Integrated Circuit (SOIC), JEDEC MS-012, 0.150 Narrow
DM74ALS251SJ	M16D	16-Lead Small Outline Package (SOP), EIAJ TYPE II, 5.3mm Wide
DM74ALS251N	N16E	16-Lead Plastic Dual-In-Line Package (PDIP), JEDEC MS-001, 0.300 Wide

Devices also available in Tape and Reel. Specify by appending the suffix letter "X" to the ordering code.

Connection Diagram

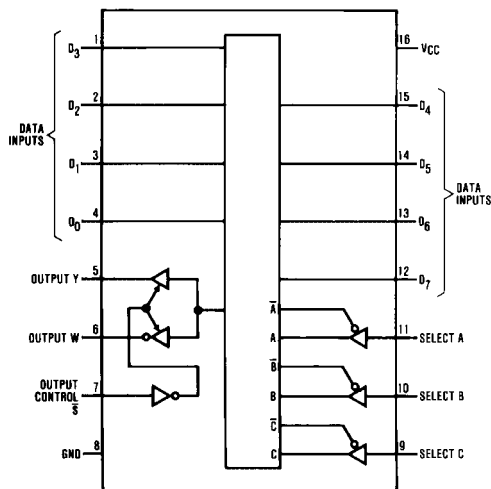

Function Table

Inputs				Outputs	
Select			Strobe	Y	W
C	B	A	\bar{S}	Y	W
X	X	X	H	Z	Z
L	L	L	L	D_0	\bar{D}_0
L	L	H	L	D_1	\bar{D}_1
L	H	L	L	D_2	\bar{D}_2
L	H	H	L	D_3	\bar{D}_3
H	L	L	L	D_4	\bar{D}_4
H	L	H	L	D_5	\bar{D}_5
H	H	L	L	D_6	\bar{D}_6
H	H	H	L	D_7	\bar{D}_7

H = HIGH Level
L = LOW Level
X = Don't Care
Z = High Impedance (OFF)
D0 thru D7 = The Level of the Respective D Input

DM74ALS251

Logic Diagram

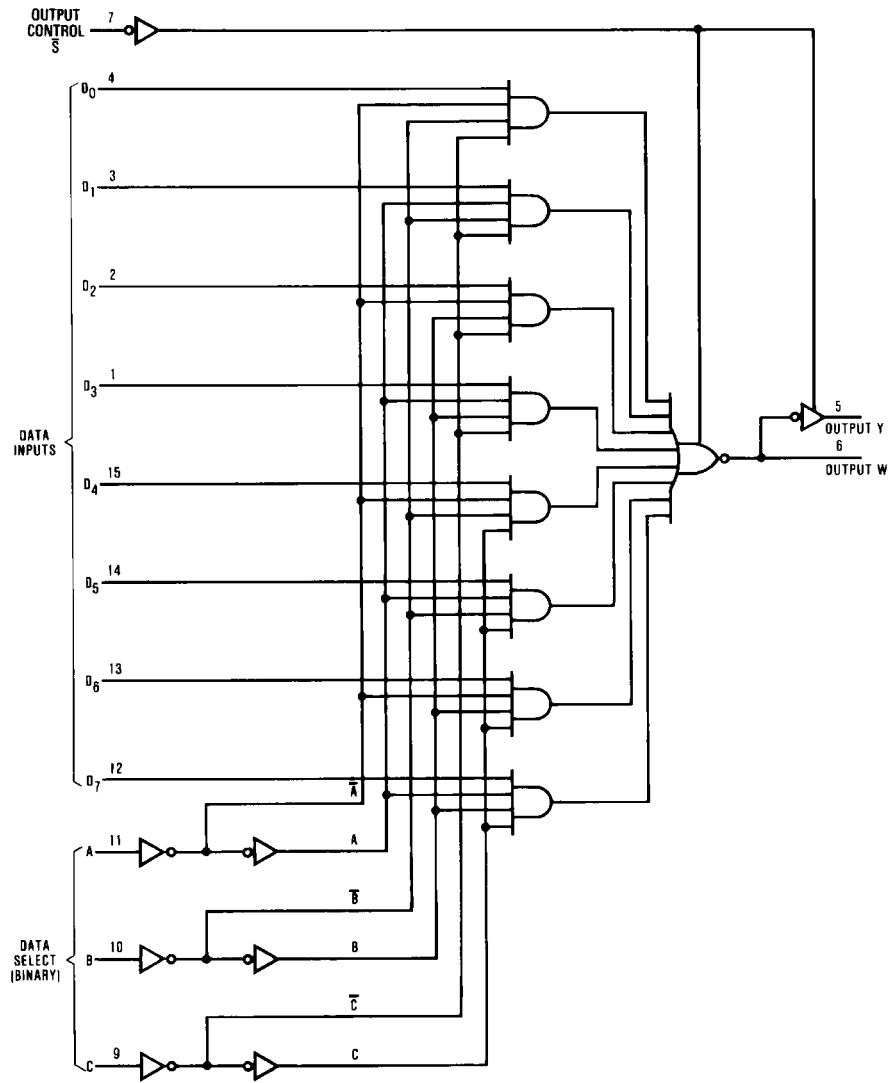

Absolute Maximum Ratings(Note 1)

Supply Voltage, V_{CC}	7V
Input Voltage	7V
Voltage Applied to Disabled Output	5.5V
Operating Free Air Temperature Range	0°C to +70°C
Storage Temperature Range	-65°C to +150°C
Typical θ_{JA}	
N Package	78.0°C/W
M Package	107.0°C/W

Note 1: The "Absolute Maximum Ratings" are those values beyond which the safety of the device cannot be guaranteed. The device should not be operated at these limits. The parametric values defined in the Electrical Characteristics tables are not guaranteed at the absolute maximum ratings. The "Recommended Operating Conditions" table will define the conditions for actual device operation.

Recommended Operating Conditions

Symbol	Parameter	Min	Nom	Max	Units
V_{CC}	Supply Voltage	4.5	5	5.5	V
V_{IH}	HIGH Level Input Voltage	2			V
V_{IL}	LOW Level Input Voltage			0.8	V
I_{OH}	HIGH Level Output Current			-2.6	mA
I_{OL}	LOW Level Output Current			24	mA
T_A	Free Air Operating Temperature	0		70	°C

Electrical Characteristics

over recommended operating free air temperature range. All typical values are measured at $V_{CC} = 5V$, $T_A = 25^\circ C$.

Symbol	Parameter	Conditions	Min	Typ	Max	Units
V_{IK}	Input Clamp Voltage	$V_{CC} = 4.5V$, $I_{IN} = -18\text{ mA}$			-1.5	V
V_{OH}	HIGH Level Output Voltage	$V_{CC} = 4.5V$, $I_{OH} = \text{Max}$	2.4	3.2		V
	Output Voltage	$I_{OH} = -400\ \mu A$, $V_{CC} = 4.5V\text{ to }5.5V$	$V_{CC}-2$			V
V_{OL}	LOW Level Output Voltage	$V_{CC} = 4.5V$		0.35	0.5	V
		$I_{OL} = 24\text{ mA}$				
I_I	Input Current at Maximum Input Voltage	$V_{CC} = 5.5V$, $V_{IH} = 7V$			0.1	mA
I_{IH}	HIGH Level Input Current	$V_{CC} = 5.5V$, $V_{IH} = 2.7V$			20	μA
I_{IL}	LOW Level Input Current	$V_{CC} = 5.5V$, $V_{IN} = 0.4V$			-0.1	mA
I_O	Output Drive Current	$V_{CC} = 5.5V$, $V_{OUT} = 2.25V$	-30		-112	mA
I_{OZH}	OFF-State Output Current, HIGH Bias	$V_{CC} = 5.5V$, $V_{OUT} = 2.7V$			20	μA
I_{OZL}	OFF-State Output Current, LOW Bias	$V_{CC} = 5.5V$, $V_{OUT} = 0.4V$			-20	μA
I_{CC}	Supply Current	$V_{CC} = 5.5V$, Inputs = GND	Enabled	7	10	mA
		Inputs = 4.5V, $V_{CC} = 5.5V$	Disabled	9.4	14	

Switching Characteristics

over recommended operating free air temperature range

Symbol	Parameter	Conditions	From	To	Min	Max	Units
t _{PLH}	Propagation Delay Time LOW-to-HIGH Level Output	V _{CC} = 4.5V to 5.5V C _L = 50 pF R _L = 500Ω	Select	Y	5	18	ns
t _{PHL}	Propagation Delay Time HIGH-to-LOW Level Output		Select		8	24	ns
t _{PLH}	Propagation Delay Time LOW-to-HIGH Level Output		Select	W	8	24	ns
t _{PHL}	Propagation Delay Time HIGH-to-LOW Level Output		Select		7	23	ns
t _{PLH}	Propagation Delay Time LOW-to-HIGH Level Output		Data	Y	2	10	ns
t _{PHL}	Propagation Delay Time HIGH-to-LOW Level Output		Data		3	15	ns
t _{PLH}	Propagation Delay Time LOW-to-HIGH Level Output		Data	W	3	15	ns
t _{PHL}	Propagation Delay Time HIGH-to-LOW Level Output		Data		3	15	ns
t _{pZH}	Output Enable Time to HIGH Level		Output Control	Y	3	15	ns
t _{pZL}	Output Enable Time to LOW Level		Output Control		3	15	ns
t _{pZH}	Output Enable Time to HIGH Level		Output Control	W	3	15	ns
t _{pZL}	Output Enable Time to LOW Level		Output Control		3	15	ns
t _{PHZ}	Output Disable Time from HIGH Level		Output Control	Y	2	10	ns
t _{PLZ}	Output Disable Time from LOW Level		Output Control		1	10	ns
t _{PHZ}	Output Disable Time from HIGH Level		Output Control	W	2	10	ns
t _{PLZ}	Output Disable Time from LOW Level		Output Control		1	10	ns

Physical Dimensions inches (millimeters) unless otherwise noted

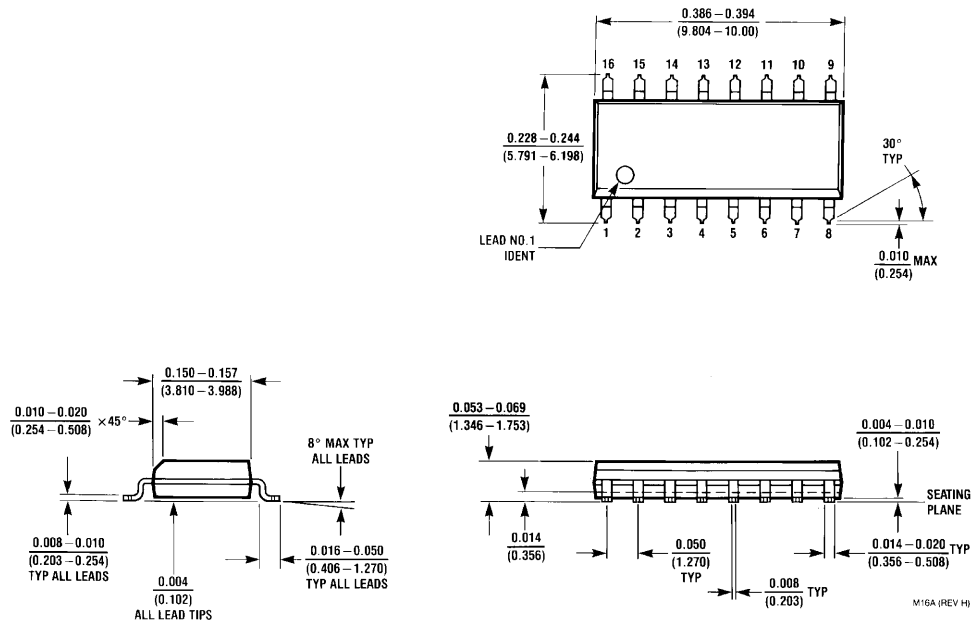

16-Lead Small Outline Integrated Circuit (SOIC), JEDEC MS-012, 0.150 Narrow Package Number M16A

M16A (REV H)

Physical Dimensions inches (millimeters) unless otherwise noted (Continued)

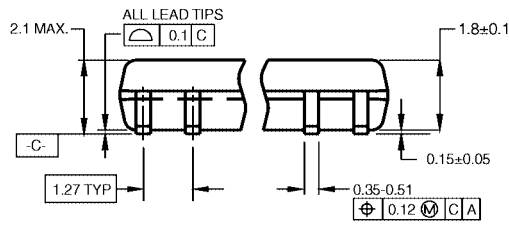
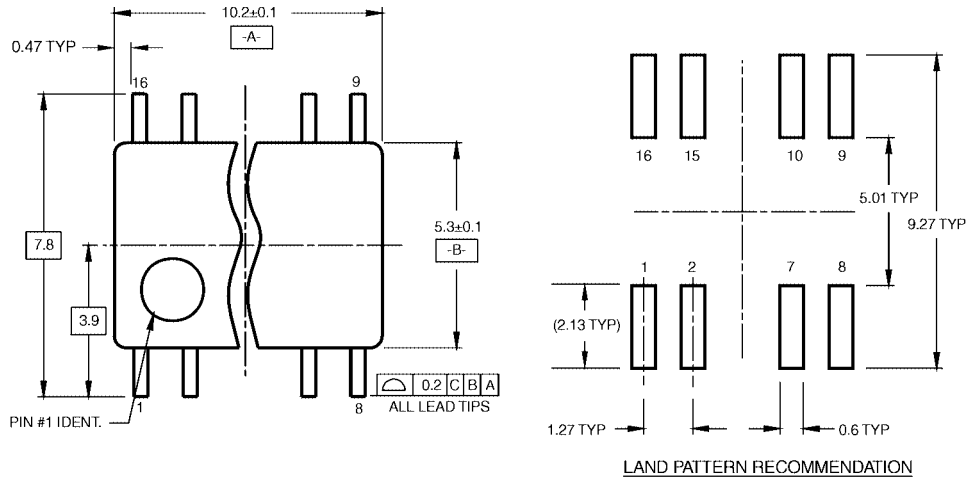

DIMENSIONS ARE IN MILLIMETERS

- NOTES:
 A. CONFORMS TO EIAJ EDR-7320 REGISTRATION, ESTABLISHED IN DECEMBER, 1998.
 B. DIMENSIONS ARE IN MILLIMETERS.
 C. DIMENSIONS ARE EXCLUSIVE OF BURRS, MOLD FLASH, AND TIE BAR EXTRUSIONS.

M16DRRevB1

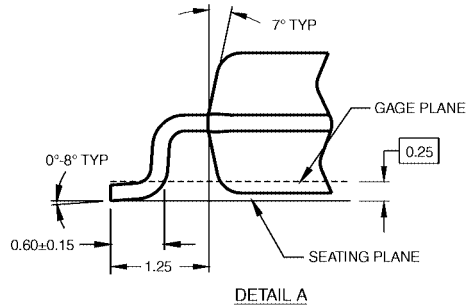

16-Lead Small Outline Package (SOP), EIAJ TYPE II, 5.3mm Wide Package Number M16D

Physical Dimensions inches (millimeters) unless otherwise noted (Continued)

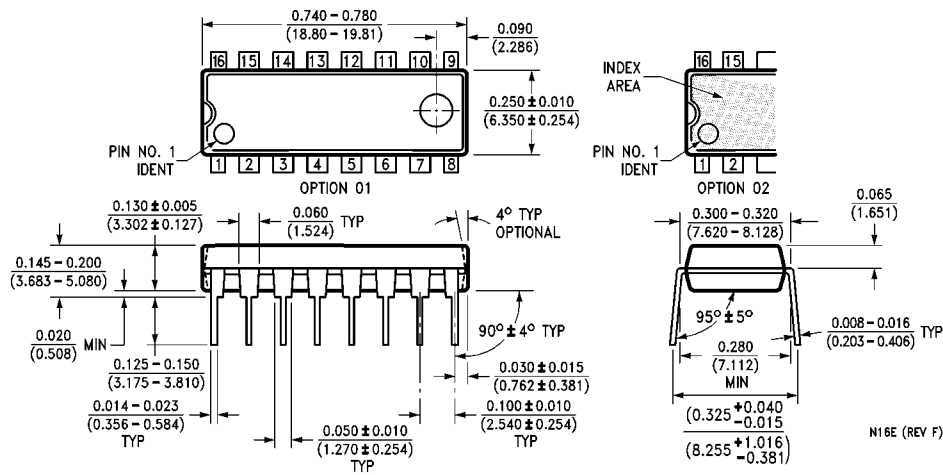

16-Lead Plastic Dual-In-Line Package (PDIP), JEDEC MS-001, 0.300 Wide Package Number N16E

Fairchild does not assume any responsibility for use of any circuitry described, no circuit patent licenses are implied and Fairchild reserves the right at any time without notice to change said circuitry and specifications.

LIFE SUPPORT POLICY

FAIRCHILD'S PRODUCTS ARE NOT AUTHORIZED FOR USE AS CRITICAL COMPONENTS IN LIFE SUPPORT DEVICES OR SYSTEMS WITHOUT THE EXPRESS WRITTEN APPROVAL OF THE PRESIDENT OF FAIRCHILD SEMICONDUCTOR CORPORATION. As used herein:

1. Life support devices or systems are devices or systems which, (a) are intended for surgical implant into the body, or (b) support or sustain life, and (c) whose failure to perform when properly used in accordance with instructions for use provided in the labeling, can be reasonably expected to result in a significant injury to the user.
2. A critical component in any component of a life support device or system whose failure to perform can be reasonably expected to cause the failure of the life support device or system, or to affect its safety or effectiveness.

www.fairchildsemi.com