

74ACT158 Quad 2-Input Multiplexer

General Description

The ACT158 is a high-speed quad 2-input multiplexer. It selects four bits of data from two sources using the common Select and Enable inputs. The four buffered outputs present the selected data in the inverted form. The ACT158 can also be used as a function generator.

Features

- I_{CC} reduced by 50%
- Outputs source/sink 24 mA
- TTL-compatible inputs

Ordering Code:

| Order Number | Package Number | Package Description |
|--------------|----------------|---|
| 74ACT158SC | M16A | 16-Lead Small Outline Integrated Circuit (SOIC), JEDEC MS-012, 0.150" Narrow Body |
| 74ACT158PC | M16D | 16-Lead Small Outline Package (SOP), EIAJ TYPE II, 5.3mm Wide |
| 74ACT158MTC | MTC16 | 16-Lead Thin Shrink Small Outline Package (TSSOP), JEDEC MO-153, 4.4mm Wide |
| 74ACT158SJ | N16E | 16-Lead Plastic Dual-In-Line Package (PDIP), JEDEC MS-001, 0.300" Wide |

Device also available in Tape and Reel. Specify by appending suffix letter "X" to the ordering code.

Logic Symbols

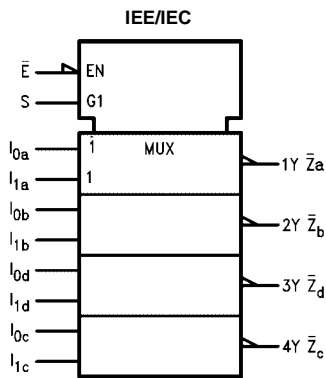
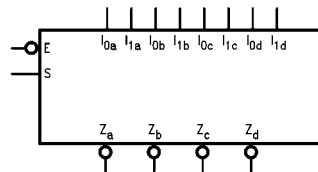

Connection Diagram

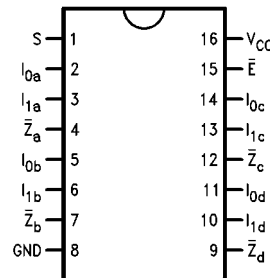

Pin Descriptions

| Pin Names | Description |
|-----------------------|----------------------|
| $I_{0a}-I_{0d}$ | Source 0 Data Inputs |
| $I_{1a}-I_{1d}$ | Source 1 Data Inputs |
| \bar{E} | Enable Input |
| S | Select Input |
| $\bar{Z}_a-\bar{Z}_d$ | Inverted Outputs |

FACT™ is a trademark of Fairchild Semiconductor Corporation.

Functional Description

The ACT158 quad 2-input multiplexer selects four bits of data from two sources under the control of a common Select input (S) and presents the data in inverted form at the four outputs. The Enable input (\bar{E}) is active-LOW. When \bar{E} is HIGH, all of the outputs (\bar{Z}) are forced HIGH regardless of all other inputs. The ACT158 is the logic implementation of a 4-pole, 2-position switch where the position of the switch is determined by the logic levels supplied to the Select input.

A common use of the ACT158 is the moving of data from two groups of registers to four common output busses. The particular register from which the data comes is determined by the state of the Select input. A less obvious use is as a function generator. The ACT158 can generate four functions of two variables with one variable common. This is useful for implementing gating functions.

Truth Table

| \bar{E} | Inputs | | | \bar{Z} |
|-----------|--------|-------|-------|-----------|
| | S | I_0 | I_1 | |
| H | X | X | X | H |
| L | L | L | X | H |
| L | L | H | X | L |
| L | H | X | L | H |
| L | H | X | H | L |

H = HIGH Voltage Level
L = LOW Voltage Level
X = Immaterial

Logic Diagram

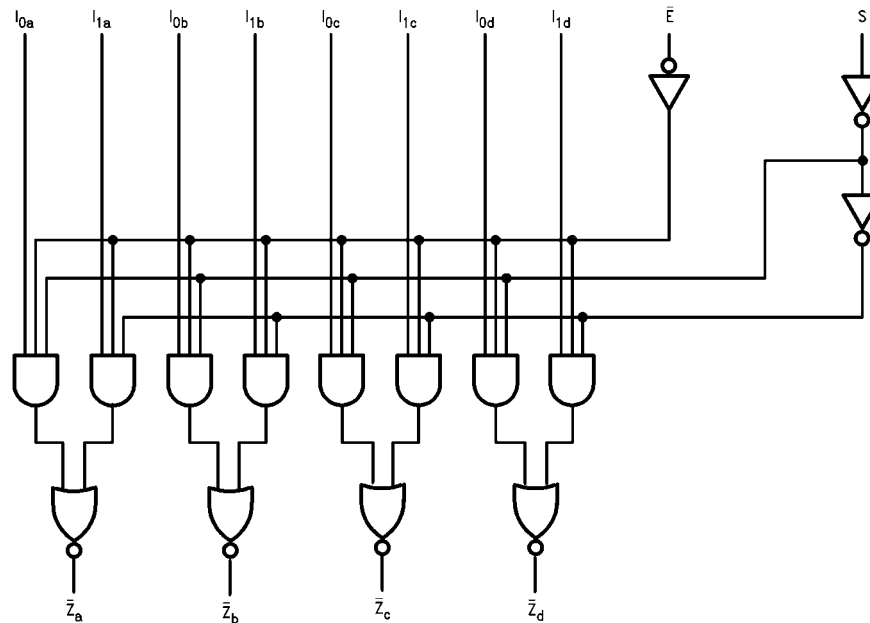

Please note that this diagram is provided only for the understanding of logic operations and should not be used to estimate propagation delays.

| Absolute Maximum Ratings ^(Note 1) | | Recommended Operating Conditions | |
|--|--------------------------|---|----------------|
| Supply Voltage (V_{CC}) | -0.5V to +7.0V | Supply Voltage (V_{CC}) | 4.5V to 5.5V |
| DC Input Diode Current (I_{IK}) | | Input Voltage (V_I) | 0V to V_{CC} |
| $V_I = -0.5V$ | -20 mA | Output Voltage (V_O) | 0V to V_{CC} |
| $V_I = V_{CC} + 0.5V$ | +20 mA | Operating Temperature (T_A) | -40°C to +85°C |
| DC Input Voltage (V_I) | -0.5V to $V_{CC} + 0.5V$ | Minimum Input Edge Rate ($\Delta V/\Delta t$) | |
| DC Output Diode Current (I_{OK}) | | V_{IN} from 0.8V to 2.0V | |
| $V_O = -0.5V$ | -20 mA | V_{CC} @ 4.5V, 5.5V | 125 mV/ns |
| $V_O = V_{CC} + 0.5V$ | +20 mA | | |
| DC Output Voltage (V_O) | -0.5V to $V_{CC} + 0.5V$ | | |
| DC Output Source or Sink Current (I_O) | ± 50 mA | | |
| DC V_{CC} or Ground Current per Output Pin (I_{CC} or I_{GND}) | ± 50 mA | | |
| Storage Temperature (T_{STG}) | -65°C to +150°C | | |
| Junction Temperature (T_J) | 140°C | | |

Note 1: Absolute maximum ratings are those values beyond which damage to the device may occur. The databook specifications should be met, without exception, to ensure that the system design is reliable over its power supply, temperature, and output/input loading variable. Fairchild does not recommend operation of FACT™ circuits outside databook specifications.

DC Electrical Characteristics

| Symbol | Parameter | V_{CC} (V) | $T_A = +25^\circ\text{C}$ | | $T_A = -40^\circ\text{C to } +85^\circ\text{C}$ | | Units | Conditions |
|-----------|---|-----------------|---------------------------|-------------------|---|---------|--|------------|
| | | | Typ | Guaranteed Limits | | | | |
| V_{IH} | Minimum HIGH Level Input Voltage | 4.5 | 1.5 | 2.0 | 2.0 | V | $V_{OUT} = 0.1V$ or $V_{CC} - 0.1V$ | |
| | | 5.5 | 1.5 | 2.0 | 2.0 | | | |
| V_{IL} | Maximum LOW Level Input Voltage | 4.5 | 1.5 | 0.8 | 0.8 | V | $V_{OUT} = 0.1V$ or $V_{CC} - 0.1V$ | |
| | | 5.5 | 1.5 | 0.8 | 0.8 | | | |
| V_{OH} | Minimum HIGH Level Output Voltage | 4.5 | 4.49 | 4.4 | 4.4 | V | $I_{OUT} = -50 \mu A$ | |
| | | 5.5 | 5.49 | 5.4 | 5.4 | | | |
| | | 4.5 | | 3.86 | 3.76 | V | $V_{IN} = V_{IL}$ or V_{IH} $I_{OH} = -24 \text{ mA}$ $I_{OH} = -24 \text{ mA (Note 2)}$ | |
| | | 5.5 | | 4.86 | 4.76 | | | |
| V_{OL} | Maximum LOW Level Output Voltage | 4.5 | 0.001 | 0.1 | 0.1 | V | $I_{OUT} = 50 \mu A$ | |
| | | 5.5 | 0.001 | 0.1 | 0.1 | | | |
| | | 4.5 | | 0.36 | 0.44 | V | $V_{IN} = V_{IL}$ or V_{IH} $I_{OL} = 24 \text{ mA}$ $I_{OL} = 24 \text{ mA (Note 2)}$ | |
| | | 5.5 | | 0.36 | 0.44 | | | |
| I_{IN} | Maximum Input Leakage Current | 5.5 | | ± 0.1 | ± 1.0 | μA | $V_I = V_{CC}, GND$ | |
| I_{CCT} | Maximum $I_{CC}/Input$ | 5.5 | 0.6 | | 1.5 | mA | $V_I = V_{CC} - 2.1V$ | |
| I_{OLD} | Minimum Dynamic Output Current (Note 3) | 5.5 | | | 75 | mA | $V_{OLD} = 1.65V$ Max | |
| I_{OHD} | | 5.5 | | | -75 | mA | $V_{OHD} = 3.85V$ Min | |
| I_{CC} | Maximum Quiescent Supply Current | 5.5 | | 4.0 | 40.0 | μA | $V_{IN} = V_{CC}$ or GND | |

Note 2: All outputs loaded; thresholds on input associated with output under test.
Note 3: Maximum test duration 2.0 ms, one output loaded at a time.

AC Electrical Characteristics

| Symbol | Parameter | V _{CC} (V) (Note 4) | T _A = +25°C C _L = 50 pF | | | T _A = -40°C to +85°C C _L = 50 pF | | Units |
|------------------|--|------------------------------------|--|-----|-----|---|------|-------|
| | | | Min | Typ | Max | Min | Max | |
| t _{PLH} | Propagation Delay S to \bar{Z}_n | 5.0 | 2.5 | 6.0 | 9.5 | 2.0 | 11.0 | ns |
| t _{PHL} | Propagation Delay S to \bar{Z}_n | 5.0 | 1.5 | 5.5 | 9.0 | 1.5 | 10.0 | ns |
| t _{PLH} | Propagation Delay \bar{E} to \bar{Z}_n | 5.0 | 1.5 | 5.5 | 9.5 | 1.5 | 10.5 | ns |
| t _{PHL} | Propagation Delay \bar{E} to \bar{Z}_n | 5.0 | 1.5 | 5.5 | 9.5 | 1.5 | 10.5 | ns |
| t _{PLH} | Propagation Delay I _n to \bar{Z}_n | 5.0 | 1.5 | 4.5 | 8.0 | 1.0 | 8.5 | ns |
| t _{PHL} | Propagation Delay I _n to \bar{Z}_n | 5.0 | 1.5 | 4.0 | 6.5 | 1.0 | 7.5 | ns |

Note 4: Voltage Range 5.0 is 5.0V ± 0.5V

Capacitance

| Symbol | Parameter | Typ | Units | Conditions |
|-----------------|-------------------------------|------|-------|------------------------|
| C _{IN} | Input Capacitance | 4.5 | pF | V _{CC} = OPEN |
| C _{PD} | Power Dissipation Capacitance | 45.0 | pF | V _{CC} = 5.0V |

Physical Dimensions inches (millimeters) unless otherwise noted

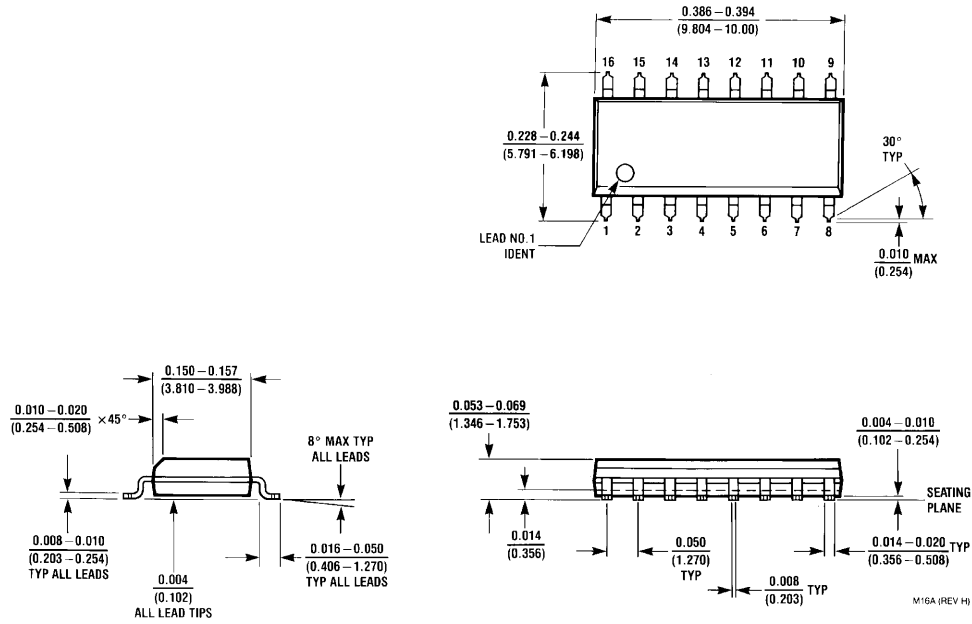

**16- Lead Small Outline Integrated Circuit (SOIC), JEDEC MS-012, 0.150" Narrow Body
Package Number M16A**

Physical Dimensions inches (millimeters) unless otherwise noted (Continued)



DIMENSIONS ARE IN MILLIMETERS

NOTES:

- A. CONFORMS TO EIAJ EDR-7320 REGISTRATION, ESTABLISHED IN DECEMBER, 1998.
- B. DIMENSIONS ARE IN MILLIMETERS.
- C. DIMENSIONS ARE EXCLUSIVE OF BURRS, MOLD FLASH, AND TIE BAR EXTRUSIONS.

M16DRRevB1

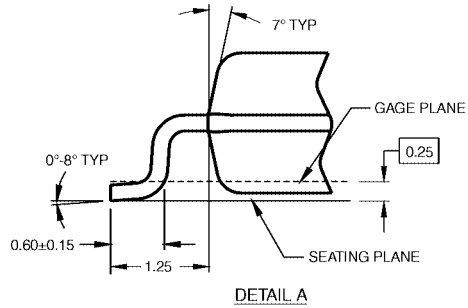
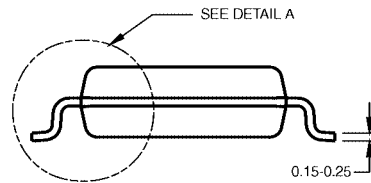

16-Lead Small Outline Package (SOP), EIAJ TYPE II, 5.3mm Wide Package Number M16D

Physical Dimensions inches (millimeters) unless otherwise noted (Continued)

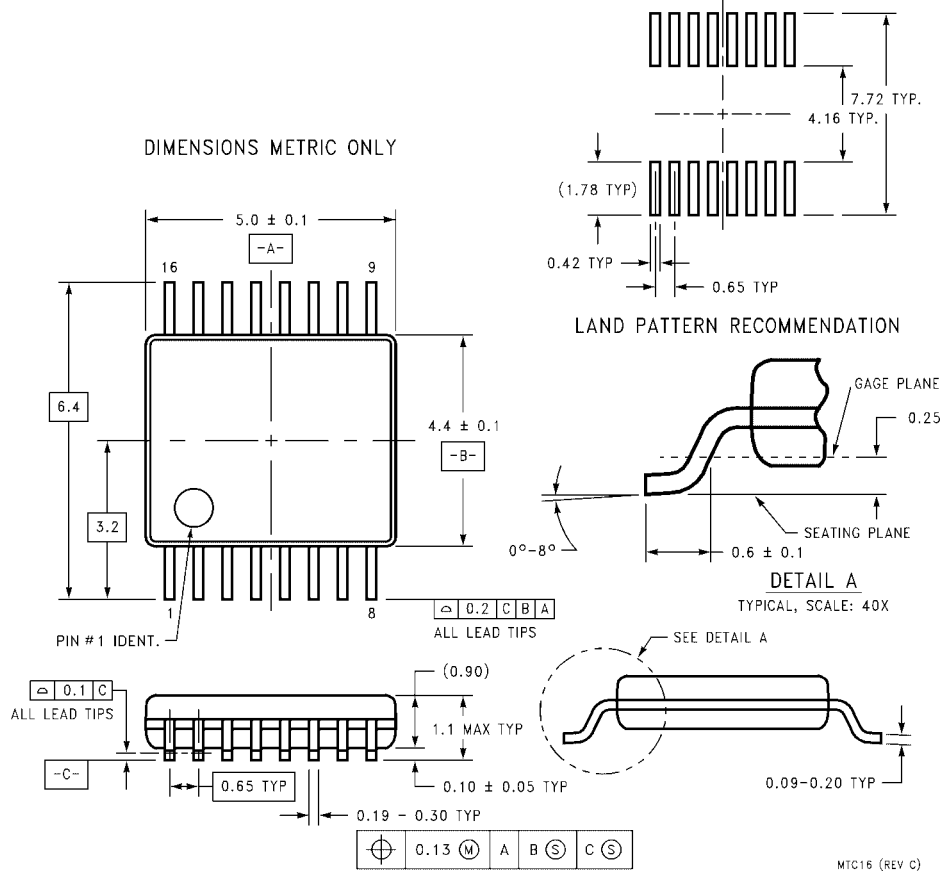

**16-Lead Thin Shrink Small Outline Package (TSSOP), JEDEC MO-153, 4.4mm Wide
Package Number MTC16**

Physical Dimensions inches (millimeters) unless otherwise noted (Continued)

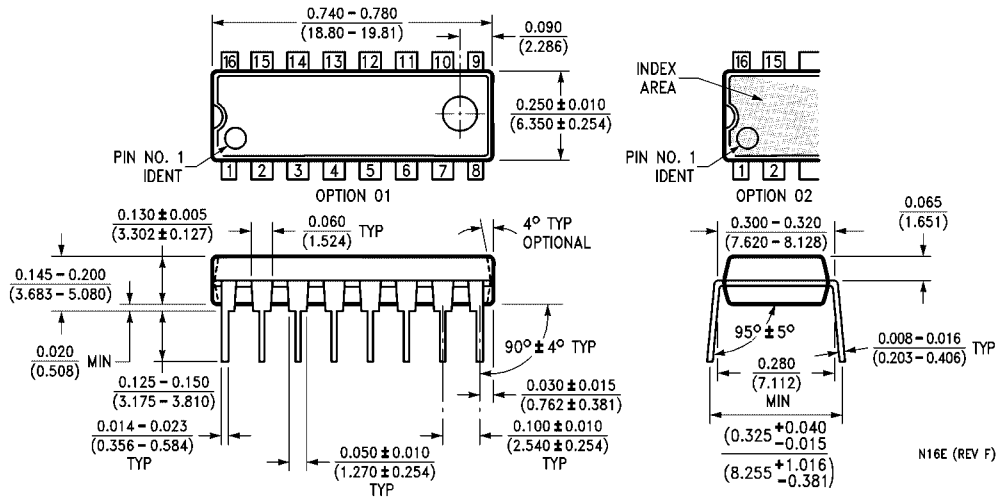

**16-Lead Plastic Dual-In-Line Package (PDIP), JEDEC MS-001, 0.300" Wide
Package Number N16E**

Fairchild does not assume any responsibility for use of any circuitry described, no circuit patent licenses are implied and Fairchild reserves the right at any time without notice to change said circuitry and specifications.

LIFE SUPPORT POLICY

FAIRCHILD'S PRODUCTS ARE NOT AUTHORIZED FOR USE AS CRITICAL COMPONENTS IN LIFE SUPPORT DEVICES OR SYSTEMS WITHOUT THE EXPRESS WRITTEN APPROVAL OF THE PRESIDENT OF FAIRCHILD SEMICONDUCTOR CORPORATION. As used herein:

1. Life support devices or systems are devices or systems which, (a) are intended for surgical implant into the body, or (b) support or sustain life, and (c) whose failure to perform when properly used in accordance with instructions for use provided in the labeling, can be reasonably expected to result in a significant injury to the user.
2. A critical component in any component of a life support device or system whose failure to perform can be reasonably expected to cause the failure of the life support device or system, or to affect its safety or effectiveness.

www.fairchildsemi.com