

DM74S257

3-STATE Quad 1-of-2 Data Selector/Multiplexer

General Description

These Schottky-clamped high-performance multiplexers feature 3-STATE outputs that can interface directly with data lines of bus-organized systems. With all but one of the common outputs disabled (at a high impedance state), the low impedance of the single enabled output will drive the bus line to a HIGH or LOW logic level. To minimize the possibility that two outputs will attempt to take a common bus to opposite logic levels, the output enable circuitry is designed such that the output disable times are shorter than the output enable times.

This 3-STATE output feature means that n-bit (paralleled) data selectors with up to 258 sources can be implemented for data buses. It also permits the use of standard TTL registers for data retention throughout the system.

Features

- 3-STATE versions S157, S158, with same pin-outs
- Schottky-clamped for significant improvement in A-C performance
- Provides bus interface from multiple sources in high-performance systems
- Average propagation delay from data input 4.8 ns
- Typical power dissipation 320 mW

Ordering Code:

Order Number	Package Number	Package Description
DM74S257N	N16E	16-Lead Plastic Dual-In-Line Package (PDIP), JEDEC MS-001, 0.300 Wide

Connection Diagram

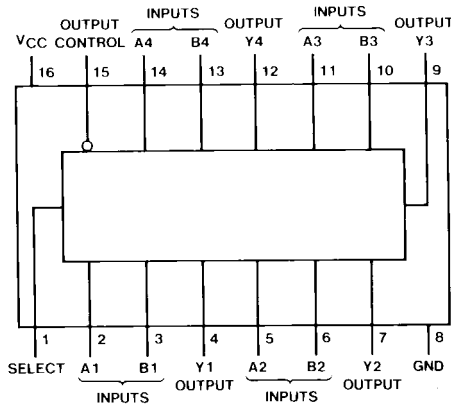

Function Table

Output Control	Inputs			Output Y
	Select	A	B	
H	X	X	X	Z
L	L	L	X	L
L	L	H	X	H
L	H	X	L	L
L	H	X	H	H

H = HIGH Level
L = LOW Level
X = Don't Care
Z = High Impedance (OFF)

DM74S257

Logic Diagram

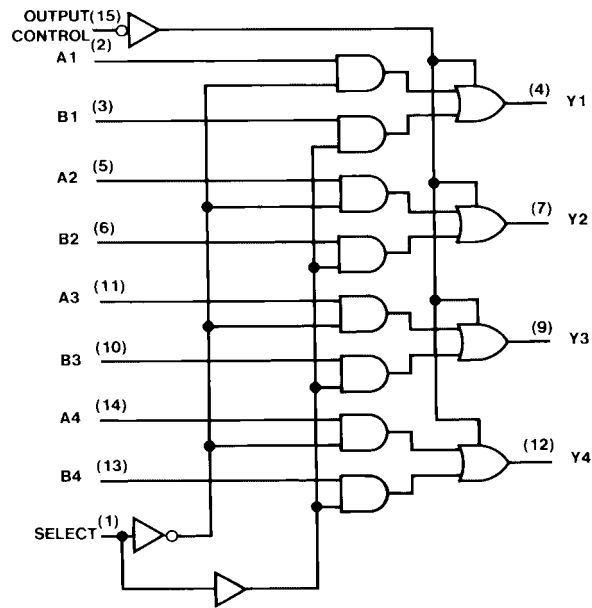

Absolute Maximum Ratings(Note 1)

Supply Voltage	7V
Input Voltage	5.5V
Operating Free Air Temperature Range	0°C to +70°C
Storage Temperature Range	-65°C to +150°C

Note 1: The "Absolute Maximum Ratings" are those values beyond which the safety of the device cannot be guaranteed. The device should not be operated at these limits. The parametric values defined in the Electrical Characteristics tables are not guaranteed at the absolute maximum ratings. The "Recommended Operating Conditions" table will define the conditions for actual device operation.

Recommended Operating Conditions

Symbol	Parameter	Min	Nom	Max	Units
V_{CC}	Supply Voltage	4.75	5	5.25	V
V_{IH}	HIGH Level Input Voltage	2			V
V_{IL}	LOW Level Input Voltage			0.8	V
I_{OH}	HIGH Level Output Current			-6.5	mA
I_{OL}	LOW Level Output Current			20	mA
T_A	Free Air Operating Temperature	0		70	°C

Electrical Characteristics

over recommended operating free air temperature (unless otherwise noted)

Symbol	Parameter	Conditions	Min	Typ (Note 2)	Max	Units
V_I	Input Clamp Voltage	$V_{CC} = \text{Min}, I_I = -18 \text{ mA}$			-1.2	V
V_{OH}	HIGH Level Output Voltage	$V_{CC} = \text{Min}, I_{OH} = \text{Max}$ $V_{IL} = \text{Max}, V_{IH} = \text{Min}$	2.4	3.2		V
V_{OL}	LOW Level Output Voltage	$V_{CC} = \text{Min}, I_{OL} = \text{Max}$ $V_{IH} = \text{Min}, V_{IL} = \text{Max}$			0.5	V
I_I	Input Current @ Max Input Voltage	$V_{CC} = \text{Max}, V_I = 5.5V$			1	mA
I_{IH}	HIGH Level Input Current	$V_{CC} = \text{Max}$ $V_I = 2.7V$	Select		100	μA
			Other		50	
I_{IL}	LOW Level Input Current	$V_{CC} = \text{Max},$ $V_I = 0.5V$	Select		-4	mA
			Other		-2	
I_{OZH}	Off-State Output Current with HIGH Level Output Voltage Applied	$V_{CC} = \text{Max}, V_O = 2.4V$ $V_{IH} = \text{Min}, V_{IL} = \text{Max}$			50	μA
I_{OZL}	Off-State Output Current with LOW Level Output Voltage Applied	$V_{CC} = \text{Max}, V_O = 0.5V$ $V_{IH} = \text{Min}, V_{IL} = \text{Max}$			-50	μA
I_{OS}	Short Circuit Output Current	$V_{CC} = \text{Max}$ (Note 3)	-40		-100	mA
I_{CCH}	Supply Current with Outputs HIGH	$V_{CC} = \text{Max}$ (Note 4)		44	68	mA
I_{CCL}	Supply Current with Outputs LOW	$V_{CC} = \text{Max}$ (Note 4)		60	93	mA
I_{CCZ}	Supply Current with Outputs Disabled	$V_{CC} = \text{Max}$ (Note 4)		64	99	mA

Note 2: All typicals are at $V_{CC} = 5V, T_A = 25^\circ\text{C}$.

Note 3: Not more than one output should be shorted at a time, and the duration should not exceed one second.

Note 4: I_{CC} is measured with all outputs OPEN and all possible inputs grounded, while achieving the stated output conditions.

Switching Characteristics

at $V_{CC} = 5V$ and $T_A = 25^\circ C$

Symbol	Parameter	From (Input) To (Output)	$R_L = 280\Omega$				Units
			$C_L = 15\text{ pF}$		$C_L = 50\text{ pF}$		
			Min	Max	Min	Max	
t_{PLH}	Propagation Delay Time LOW-to-HIGH Level Output	Data to Output		7.5		11	ns
t_{PHL}	Propagation Delay Time HIGH-to-LOW Level Output	Data to Output		6.5		10	ns
t_{PLH}	Propagation Delay Time LOW-to-HIGH Level Output	Select to Output		15		16	ns
t_{PHL}	Propagation Delay Time HIGH-to-LOW Level Output	Select to Output		15		16	ns
t_{PZH}	Output Enable Time to HIGH Level Output	Output Control to Y		19.5		23	ns
t_{PZL}	Output Enable Time to LOW Level Output	Output Control to Y		21		24	ns
t_{PHZ}	Output Disable Time to HIGH Level Output (Note 5)	Output Control to Y		8.5			ns
t_{PLZ}	Output Disable Time to LOW Level Output (Note 5)	Output Control to Y		14			ns

Note 5: $C_L = 5\text{ pF}$.

Physical Dimensions inches (millimeters) unless otherwise noted

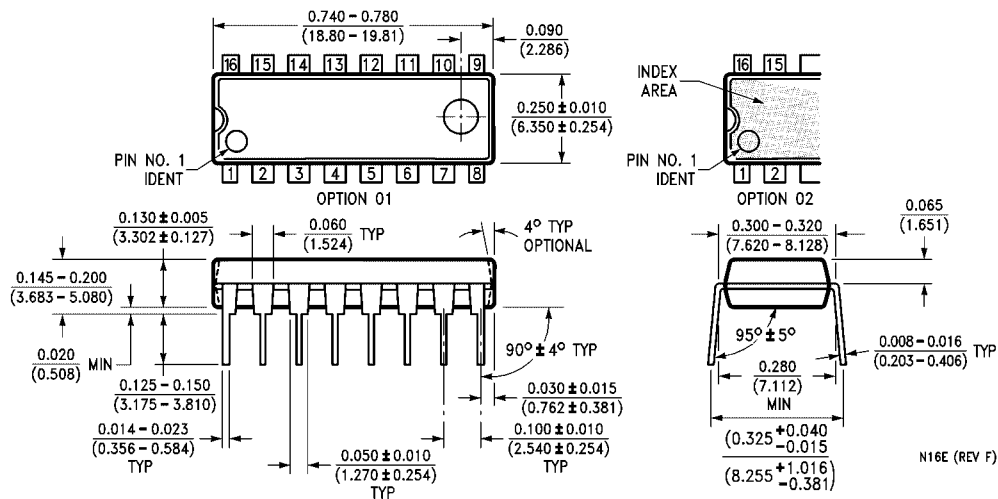

16-Lead Plastic Dual-In-Line Package (PDIP), JEDEC MS-001, 0.300 Wide Package Number N16E

Fairchild does not assume any responsibility for use of any circuitry described, no circuit patent licenses are implied and Fairchild reserves the right at any time without notice to change said circuitry and specifications.

LIFE SUPPORT POLICY

FAIRCHILD'S PRODUCTS ARE NOT AUTHORIZED FOR USE AS CRITICAL COMPONENTS IN LIFE SUPPORT DEVICES OR SYSTEMS WITHOUT THE EXPRESS WRITTEN APPROVAL OF THE PRESIDENT OF FAIRCHILD SEMICONDUCTOR CORPORATION. As used herein:

1. Life support devices or systems are devices or systems which, (a) are intended for surgical implant into the body, or (b) support or sustain life, and (c) whose failure to perform when properly used in accordance with instructions for use provided in the labeling, can be reasonably expected to result in a significant injury to the user.
2. A critical component in any component of a life support device or system whose failure to perform can be reasonably expected to cause the failure of the life support device or system, or to affect its safety or effectiveness.

www.fairchildsemi.com