

NL7SZ18

1-to-2 Demultiplexer with 3-State Deselected Output

The NL7SZ18 is a high-performance non-inverting 1-to-2 demultiplexer. With the Select input [S] at Low, data at A is passed to Y0 and Y1 is set to high impedance. With the Select input [S] at High, data at A is passed to Y1 and Y0 is set to high impedance. The device operates over the voltage range from 1.65 V to 5.5 V.

This device has been optimized for on-board buffering applications and offers mixed (1.65 V, 2.3 V, 3.0 V and 5.5 V) voltage capability by providing over voltage tolerance (OVT*) circuitry on I/O pins.

Features

- High-Speed Propagation Delay
 t_{PD} 2.5 nS (Typ), Load 50 pF @ 5.0 V
- Power Down Impedance
 Outputs in High-Z
- Output Drive Capability
 32 mA @ 5.0 V
- Broad V_{CC} Operating Range
 1.65 V to 5.5 V
- Surface Mount Technology
 SC-70, 6-Lead and UDFN6 Packaging
- OVT* on Inputs/Outputs
- Pb-Free Package is Available

Typical Applications

- Cell Phones
- PDAs
- Digital Cameras
- Video Cameras

Important Information

- ESD Protection: MM >200 V, Human Body Model >2000 V
- Latch-Up Max Rating: 300 mA
- Pin-to-Pin Compatible with NC7SZ18

*Over Voltage Tolerance (OVT) enables input and output pins to function outside (higher) of their operating voltages, with no damage to the devices or to signal integrity.

PIN/FUNCTION TABLE

| Pin | Function |
|----------------|----------------------|
| A | Data Input |
| S | Demultiplexer Select |
| Y ₀ | Output 1 |
| Y ₁ | Output 2 |



ON Semiconductor®

<http://onsemi.com>

MARKING DIAGRAMS

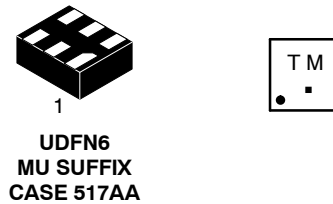
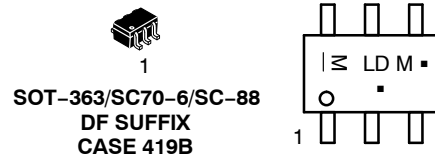

LD, T = Device Marking
 M = Date Code*
 ■ = Pb-Free Package

(Note: Microdot may be in either location)

*Date Code orientation and/or position may vary depending upon manufacturing location.

PIN ASSIGNMENT

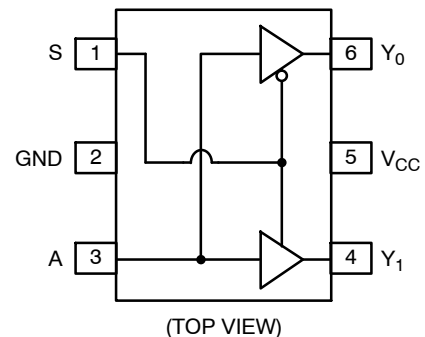

TRUTH TABLE

| Input | | Output | |
|-------|---|----------------|----------------|
| S | A | Y ₀ | Y ₁ |
| L | L | L | Z |
| L | H | H | Z |
| H | L | Z | L |
| H | H | Z | H |

ORDERING INFORMATION

See detailed ordering and shipping information in the package dimensions section on page 2 of this data sheet.

NL7SZ18

MAXIMUM RATINGS

| Rating | Symbol | Value | Unit |
|--|---|------------------------|---------------|
| DC Supply Voltage | V_{CC} | -0.5 to +7.0 | V |
| DC Input Voltage | V_{IN} | -0.5 to +7.0 | V |
| DC Output Voltage | V_{OUT} | -0.5 to +7.0 | V |
| DC Input Diode Current @ $V_1 < -0.5$ V | I_{IK} | -50 | mA |
| DC Output Diode Current @ $V_1 < -0.5$ V | I_{OK} | -50 | mA |
| DC Output Sink Current | I_{OUT} | ± 50 | mA |
| DC Supply Current per Supply Pin | I_{CC} | ± 100 | mA |
| DC Ground Current per Ground Pin | I_{GND} | ± 100 | mA |
| Storage Temperature Range | T_{STG} | -65 to +150 | $^{\circ}C$ |
| Lead Temperature, 1 mm from Case for 10 Seconds | T_L | 260 | $^{\circ}C$ |
| Junction Temperature Under Bias | T_J | +150 | $^{\circ}C$ |
| Thermal Resistance (Note 1) | θ_{JA} | 250 | $^{\circ}C/W$ |
| Power Dissipation in Still Air at 85 $^{\circ}C$ | P_D | 180 | mW |
| Moisture Sensitivity | MSL | Level 1 | - |
| Flammability Rating | Oxygen Index: 28 to 34 F_R | UL 94 V-0 @ 0125 in | - |
| ESD Withstand Voltage | Human Body Model (Note 2) Machine Model (Note 3) Charged Device Model (Note 4) V_{ESD} | > 2000 > 200 n/a | V |

Stresses exceeding Maximum Ratings may damage the device. Maximum Ratings are stress ratings only. Functional operation above the Recommended Operating Conditions is not implied. Extended exposure to stresses above the Recommended Operating Conditions may affect device reliability.

1. Measured with minimum pad spacing on an FR4 board, using 10 mm-by-1 inch, 2 ounce copper trace no air flow.
2. Tested to EIA/JESD22-A114-A.
3. Tested to EIA/JESD22-A115-A.
4. Tested to JESD22-C101-A.

RECOMMENDED OPERATING CONDITIONS

| Rating | Symbol | Value | Unit |
|-----------------------------------|---------------|---|---|
| DC Supply Voltage | V_{CC} | 1.65 to 5.5 | V |
| DC Supply Voltage, Data Retention | V_{CC} | 1.5 to 5.5 | V |
| Input Voltage | V_{IN} | 0 to 5.5 | V |
| Output Voltage | V_{OUT} | 0 to 5.5 | V |
| Operating Temperature | T_A | -55 to 125 | $^{\circ}C$ |
| Input Rise and Fall Times | t_r, t_f | V_{CC} @ 1.8 \pm 0.15 V V_{CC} @ 2.5 \pm 0.2 V V_{CC} @ 3.3 \pm 0.3 V V_{CC} @ 5.0 \pm 0.5 V | 0 to 20 0 to 20 0 to 10 0 to 5 |
| Thermal Resistance | θ_{JA} | 350 | $^{\circ}C/W$ |

ORDERING INFORMATION

| Device Order Number | Package | Shipping [†] |
|---------------------|---------------------|-----------------------|
| NL7SZ18DFT2 | SC70-6 | 3000 / Tape & Reel |
| NL7SZ18DFT2G | SC70-6 (Pb-Free) | 3000 / Tape & Reel |
| NL7SZ18MUR2G | UDFN6 (Pb-Free) | 3000 / Tape & Reel |

[†]For information on tape and reel specifications, including part orientation and tape sizes, please refer to our Tape and Reel Packaging Specifications Brochure, BRD8011/D.

NL7SZ18

DC ELECTRICAL CHARACTERISTICS

| Parameter | Condition | | Symbol | V _{CC} (V) | T _A = 25°C | | | T _A = -55°C to 125°C | | Unit |
|---------------------------|--|--|------------------|---------------------------|--|--------------------------------------|--|--|--|------|
| | | | | | Min | Typ | Max | Min | Max | |
| High-Level Input Voltage | | | V _{IH} | 1.65–1.95 2.3–5.5 | 0.75 V _{CC} 0.70 V _{CC} | | | 0.75 V _{CC} 0.70 V _{CC} | | V |
| Low-Level Output Voltage | | | V _{IL} | 1.65–1.95 2.3–5.5 | | | 0.25 V _{CC} 0.30 V _{CC} | | 0.25 V _{CC} 0.30 V _{CC} | V |
| High-Level Output Voltage | V _{IN} = V _{IH} | I _{OH} = -100 µA | V _{OH} | 1.65 2.3 3.0 4.5 | 1.55 2.20 2.90 4.40 | 1.65 2.30 3.00 4.50 | | 1.55 2.20 2.90 4.40 | | V |
| | | I _{OH} = -4.0 mA I _{OH} = -8.0 mA I _{OH} = -16 mA I _{OH} = -24 mA I _{OH} = -32 mA | | 1.65 2.3 3.0 4.5 | 1.29 1.90 2.40 2.30 3.80 | 1.52 2.15 2.80 2.68 4.20 | | 1.29 1.90 2.40 2.30 3.80 | | |
| Low-Level Output Voltage | V _{IN} = V _{IL} | I _{OL} = 100 µA | V _{OL} | 1.65 2.3 3.0 4.5 | | 0.0 0.0 0.0 0.0 | 0.10 0.10 0.10 0.10 | | 0.10 0.10 0.10 0.10 | V |
| | | I _{OL} = 4.0 mA I _{OL} = 8.0 mA I _{OL} = 16 mA I _{OL} = 24 mA I _{OL} = 32 mA | | 1.65 2.3 3.0 4.5 | | 0.08 0.10 0.15 0.22 0.22 | 0.24 0.30 0.40 0.55 0.55 | | 0.24 0.30 0.40 0.55 0.55 | |
| Input Leakage Current | V _{IN} = 5.5 V, GND | | I _{IN} | 0.0 to 5.5 | | | ±0.1 | | ±1.0 | µA |
| Output High-Z Current | V _{IN} = V _{IH} or V _{IL} 0 < V _{out} ≤ 5.5 V | | I _{OZ} | 1.65 to 5.5 | | | ±0.5 | | ±5.0 | µA |
| Power-Off Leakage Current | V _{IN} or V _{CC} = 5.5 V | | I _{OFF} | 0.0 | | | 1.0 | | 10 | µA |
| Quiescent Supply Current | V _{IN} = 5.5 V, GND | | I _{CC} | 1.8 to 5.5 | | | 1.0 | | 10 | µA |

AC ELECTRICAL CHARACTERISTICS

| Parameter | Condition | Figure | Symbol | V _{CC} | T _A = 25°C | | | T _A = -55°C to 125°C | | Unit |
|----------------------------------|---|------------------|--------------------------------------|-----------------|--|---|------------------|--------------------------------------|------------|------|
| | | | | | Min | Typ | Max | Min | Max | |
| | | | | | Propagation Delay A to Y ₀ or Y ₁ | C _L = 15 pF R _D = 1.0 MΩ S = OPEN | Figures 1 & 3 | t _{PLH} t _{PHL} | 1.8 ± 0.15 | |
| | C _L = 50 pF R _D = 500 Ω S = OPEN | 2.5 ± 0.2 | 1.0 | 3.6 | 5.7 | 1.0 | | | 6.0 | |
| | | | | 3.3 ± 0.3 | 0.8 | 2.7 | 4.0 | 0.8 | 4.3 | |
| | | | | 5.0 ± 0.5 | 0.5 | 2.0 | 3.1 | 0.5 | 3.3 | |
| | | | | 3.3 ± 0.3 | 1.2 | 3.4 | 4.9 | 1.2 | 5.4 | nS |
| | | | | 5.0 ± 0.5 | 0.8 | 2.5 | 3.9 | 0.8 | 4.2 | |
| Output Enable Time | C _L = 50 pF R _D , R _U = 500 Ω S = GND for t _{PZH} S = V _{IN} for t _{PZL} V _I = 2 × V _{CC} | Figures 1 & 3 | t _{PZL} t _{PZH} | 1.8 ± 0.15 | 3.0 | 6.9 | 12 | 3.0 | 12.5 | nS |
| | | | | 2.5 ± 0.2 | 1.8 | 4.2 | 6.8 | 1.8 | 7.3 | |
| | | | | 3.3 ± 0.3 | 1.2 | 3.2 | 5.0 | 1.2 | 5.5 | |
| | | | | 5.0 ± 0.5 | 0.8 | 2.5 | 4.0 | 0.8 | 4.3 | |
| | | | | 1.8 ± 0.15 | 2.5 | 6.0 | 10 | 2.5 | 10.5 | nS |
| | | | | 2.5 ± 0.2 | 1.5 | 4.0 | 6.8 | 1.5 | 7.1 | |
| | | | | 3.3 ± 0.3 | 0.8 | 2.9 | 4.9 | 0.8 | 5.3 | |
| | | | | 5.0 ± 0.5 | 0.3 | 1.8 | 3.5 | 0.3 | 3.7 | |
| Input Capacitance | | | C _{IN} | OPEN | | 2.5 | | | | pF |
| Output Capacitance | | | C _{OUT} | 3.3 | | 4.0 | | | | pF |
| Power Dissipation Capacitance | Note 5 | Figure 2 | C _{PD} | 3.3 5.0 | | 16 19.5 | | | | pF |

5. C_{PD} is defined as the value of the internal equivalent capacitance which is derived from dynamic operating current consumption (I_{CCD}) at no output loading and operating at 50% duty cycle (see Figure 2). C_{PD} is related to I_{CCD} dynamic operating current by the expression: I_{CCD} = (C_{PD}) (V_{CC}) (f_{IN}) + (I_{CCD}static).

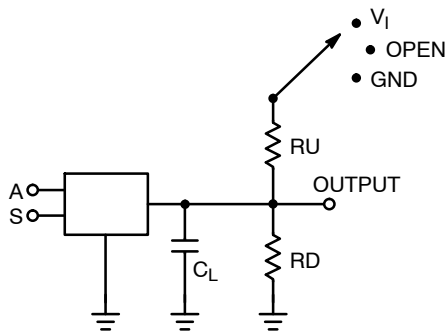

Figure 1. AC Test Circuit

C_L Includes Load and Stray Capacitance
Input PRR = 1.0 MHz; t_w = 500 nS

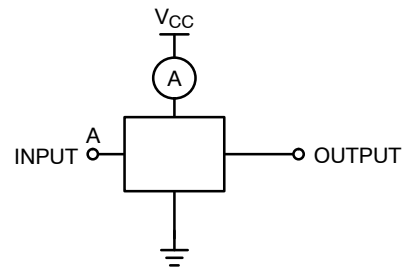

Figure 2. I_{CCD} Test Circuit

Input = AC Waveform; t_r = t_f = 1.8 nS
PRR = 10 MHz; Duty Cycle = 50%
S Input = GND or x

NL7SZ18

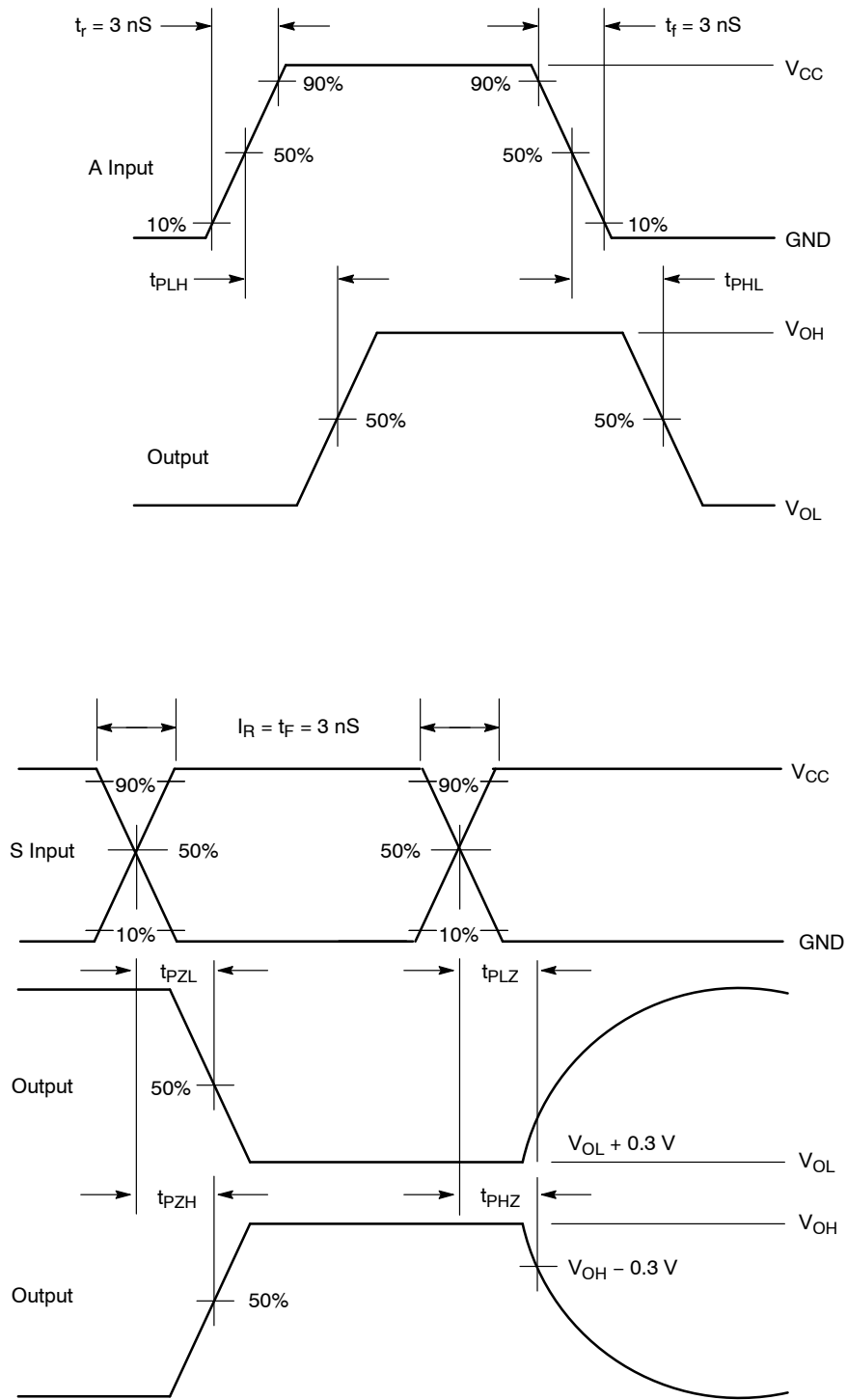
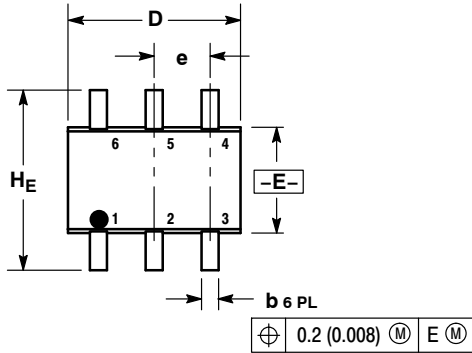

Figure 3. AC Waveforms

NL7SZ18

PACKAGE DIMENSIONS

SC-88/SC70-6/SOT-363
CASE 419B-02
ISSUE W



NOTES:

1. DIMENSIONING AND TOLERANCING PER ANSI Y14.5M, 1982.
2. CONTROLLING DIMENSION: INCH.
3. 419B-01 OBSOLETE, NEW STANDARD 419B-02.

| DIM | MILLIMETERS | | | INCHES | | |
|----------------|-------------|------|------|-----------|-------|-------|
| | MIN | NOM | MAX | MIN | NOM | MAX |
| A | 0.80 | 0.95 | 1.10 | 0.031 | 0.037 | 0.043 |
| A1 | 0.00 | 0.05 | 0.10 | 0.000 | 0.002 | 0.004 |
| A3 | 0.20 REF | | | 0.008 REF | | |
| b | 0.10 | 0.21 | 0.30 | 0.004 | 0.008 | 0.012 |
| C | 0.10 | 0.14 | 0.25 | 0.004 | 0.005 | 0.010 |
| D | 1.80 | 2.00 | 2.20 | 0.070 | 0.078 | 0.086 |
| E | 1.15 | 1.25 | 1.35 | 0.045 | 0.049 | 0.053 |
| e | 0.65 BSC | | | 0.026 BSC | | |
| L | 0.10 | 0.20 | 0.30 | 0.004 | 0.008 | 0.012 |
| H _E | 2.00 | 2.10 | 2.20 | 0.078 | 0.082 | 0.086 |

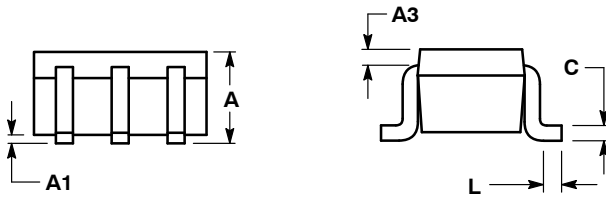

SOLDERING FOOTPRINT*

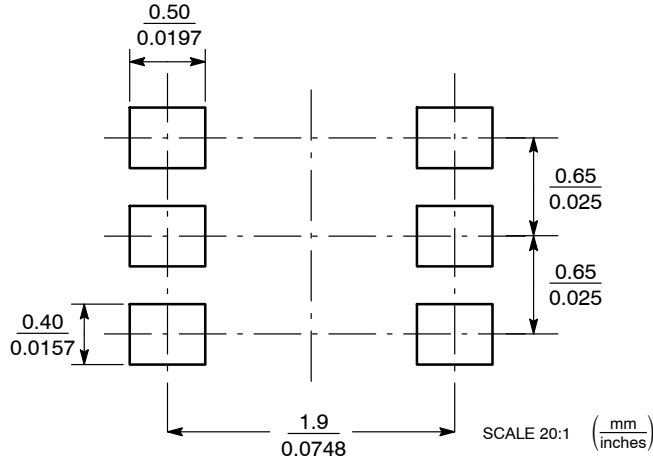

*For additional information on our Pb-Free strategy and soldering details, please download the ON Semiconductor Soldering and Mounting Techniques Reference Manual, SOLDERRM/D.

NL7SZ18

PACKAGE DIMENSIONS

UDFN6, 1.2x1.0, 0.4P
CASE 517AA-01
ISSUE D

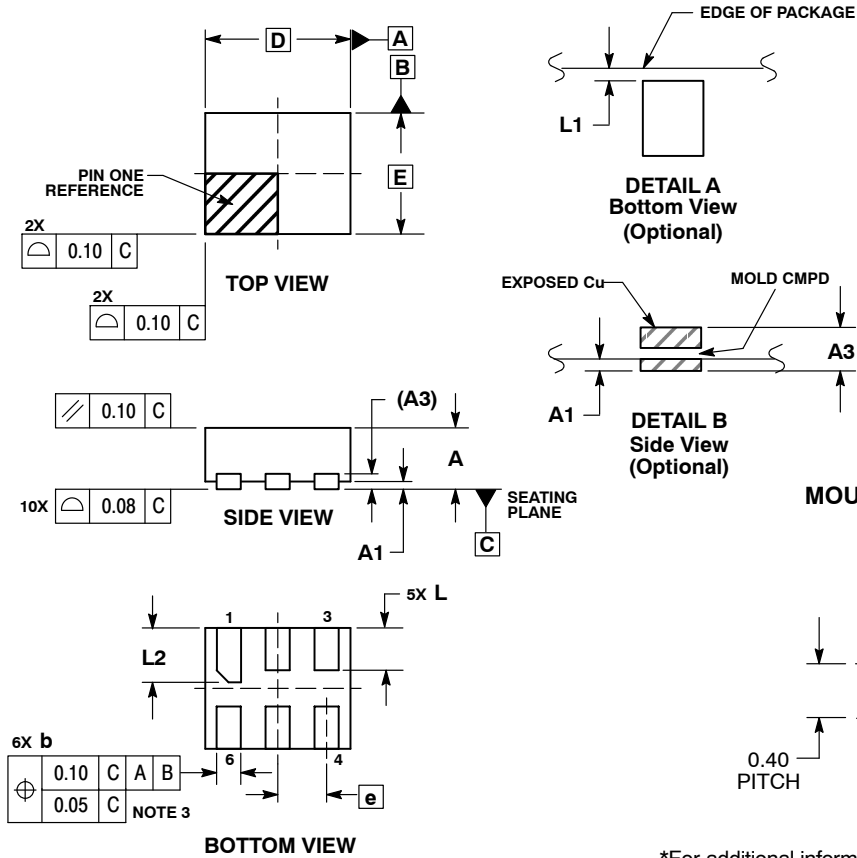

- NOTES:
1. DIMENSIONING AND TOLERANCING PER ASME Y14.5M, 1994.
 2. CONTROLLING DIMENSION: MILLIMETERS.
 3. DIMENSION b APPLIES TO PLATED TERMINAL AND IS MEASURED BETWEEN 0.25 AND 0.30 mm FROM TERMINAL.
 4. COPLANARITY APPLIES TO THE EXPOSED PAD AS WELL AS THE TERMINALS.

| MILLIMETERS | | |
|-------------|-----------|------|
| DIM | MIN | MAX |
| A | 0.45 | 0.55 |
| A1 | 0.00 | 0.05 |
| A3 | 0.127 REF | |
| b | 0.15 | 0.25 |
| D | 1.20 | BSC |
| E | 1.00 | BSC |
| e | 0.40 | BSC |
| L | 0.30 | 0.40 |
| L1 | 0.00 | 0.15 |
| L2 | 0.40 | 0.50 |

MOUNTING FOOTPRINT*

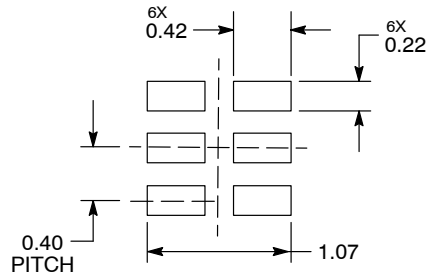

DIMENSIONS: MILLIMETERS

*For additional information on our Pb-Free strategy and soldering details, please download the ON Semiconductor Soldering and Mounting Techniques Reference Manual, SOLDERRM/D.

ON Semiconductor and are registered trademarks of Semiconductor Components Industries, LLC (SCILLC). SCILLC reserves the right to make changes without further notice to any products herein. SCILLC makes no warranty, representation or guarantee regarding the suitability of its products for any particular purpose, nor does SCILLC assume any liability arising out of the application or use of any product or circuit, and specifically disclaims any and all liability, including without limitation special, consequential or incidental damages. "Typical" parameters which may be provided in SCILLC data sheets and/or specifications can and do vary in different applications and actual performance may vary over time. All operating parameters, including "Typicals" must be validated for each customer application by customer's technical experts. SCILLC does not convey any license under its patent rights nor the rights of others. SCILLC products are not designed, intended, or authorized for use as components in systems intended for surgical implant into the body, or other applications intended to support or sustain life, or for any other application in which the failure of the SCILLC product could create a situation where personal injury or death may occur. Should Buyer purchase or use SCILLC products for any such unintended or unauthorized application, Buyer shall indemnify and hold SCILLC and its officers, employees, subsidiaries, affiliates, and distributors harmless against all claims, costs, damages, and expenses, and reasonable attorney fees arising out of, directly or indirectly, any claim of personal injury or death associated with such unintended or unauthorized use, even if such claim alleges that SCILLC was negligent regarding the design or manufacture of the part. SCILLC is an Equal Opportunity/Affirmative Action Employer. This literature is subject to all applicable copyright laws and is not for resale in any manner.

PUBLICATION ORDERING INFORMATION

LITERATURE FULFILLMENT:
Literature Distribution Center for ON Semiconductor
P.O. Box 5163, Denver, Colorado 80217 USA
Phone: 303-675-2175 or 800-344-3860 Toll Free USA/Canada
Fax: 303-675-2176 or 800-344-3867 Toll Free USA/Canada
Email: orderlit@onsemi.com

N. American Technical Support: 800-282-9855 Toll Free
USA/Canada
Europe, Middle East and Africa Technical Support:
Phone: 421 33 790 2910
Japan Customer Focus Center
Phone: 81-3-5773-3850

ON Semiconductor Website: www.onsemi.com
Order Literature: <http://www.onsemi.com/orderlit>
For additional information, please contact your local Sales Representative

NL7SZ18/D