

# LM384

## 5W Audio Power Amplifier

### General Description

The LM384 is a power audio amplifier for consumer applications. In order to hold system cost to a minimum, gain is internally fixed at 34 dB. A unique input stage allows ground referenced input signals. The output automatically self-centers to one-half the supply voltage.

The output is short-circuit proof with internal thermal limiting. The package outline is standard dual-in-line. A copper lead frame is used with the center three pins on either side comprising a heat sink. This makes the device easy to use in standard p-c layout.

Uses include simple phonograph amplifiers, intercoms, line drivers, teaching machine outputs, alarms, ultrasonic drivers, TV sound systems, AM-FM radio, sound projector systems, etc. See AN-69 for circuit details.

### Features

- Wide supply voltage range: 12V to 26V
- Low quiescent power drain
- Voltage gain fixed at 50
- High peak current capability: 1.3A
- Input referenced to GND
- High input impedance: 150k $\Omega$
- Low distortion: 0.25% ( $P_O=4W$ ,  $R_L=8\Omega$ )
- Quiescent output voltage is at one half of the supply voltage
- Standard dual-in-line package

### Schematic Diagram

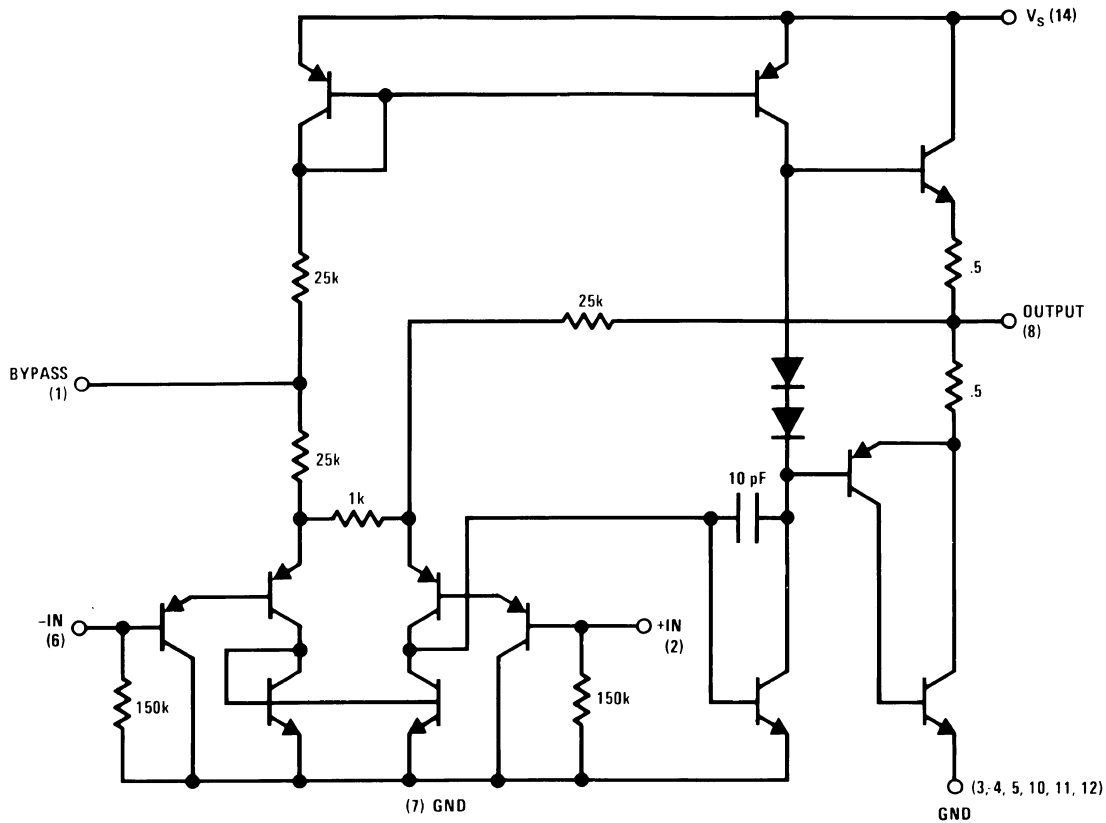

00784303

**Absolute Maximum Ratings** (Note 1)

If Military/Aerospace specified devices are required, please contact the National Semiconductor Sales Office/ Distributors for availability and specifications.

Supply Voltage	28V
Peak Current	1.3A
Power Dissipation (See (Notes 4, 5))	1.67W
Input Voltage	±0.5V
Storage Temperature	-65°C to +150°C

Operating Temperature	0°C to +70°C
Lead Temperature (Soldering, 10 sec.)	260°C
Thermal Resistance	
$\theta_{JC}$	30°C/W
$\theta_{JA}$	79°C/W

**Note 1:** Absolute Maximum Ratings indicate limits beyond which damage to the device may occur. Operating Ratings indicate conditions for which the device is functional, but do not guarantee specific performance limits.

**Electrical Characteristics** (Note 2)

Symbol	Parameter	Conditions	Min	Typ	Max	Units
$Z_{IN}$	Input Resistance			150		k $\Omega$
$I_{BIAS}$	Bias Current	Inputs Floating		100		nA
$A_V$	Gain		40	50	60	V/V
$P_{OUT}$	Output Power	THD = 10%, $R_L = 8\Omega$	5	5.5		W
$I_Q$	Quiescent Supply Current			8.5	25	mA
$V_{OUT Q}$	Quiescent Output Voltage			11		V
BW	Bandwidth	$P_{OUT} = 2W, R_L = 8\Omega$		450		kHz
$V^+$	Supply Voltage		12		26	V
$I_{SC}$	Short Circuit Current (Note 6)			1.3		A
$PSRR_{RTO}$	Power Supply Rejection Ratio (Note 3)			31		dB
THD	Total Harmonic Distortion	$P_{OUT} = 4W, R_L = 8\Omega$		0.25	1.0	%

**Note 2:**  $V^+ = 22V$  and  $T_A = 25^\circ C$  operating with a Staver V7 heat sink for 30 seconds.

**Note 3:** Rejection ratio referred to the output with  $C_{BYPASS} = 5 \mu F$ , freq = 120 Hz.

**Note 4:** The maximum junction temperature of the LM384 is 150°C.

**Note 5:** The package is to be derated at 15°C/W junction to heat sink pins.

**Note 6:** Output is fully protected against a shorted speaker condition at all voltages up to 22V.

**Heat Sink Dimensions**

Staver "V7" Heat Sink

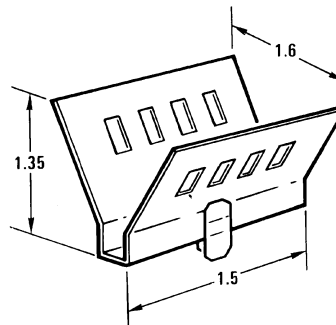

00784304

Staver Company  
41 Saxon Ave.  
P.O. Drawer H  
Bay Shore, N.Y.  
Tel: (516) 666-8000

# Typical Performance Characteristics

**Device Dissipation vs Ambient Temperature**

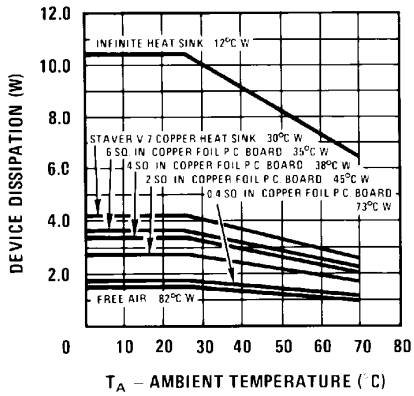

00784310

**Thermal Resistance vs Square Inches**

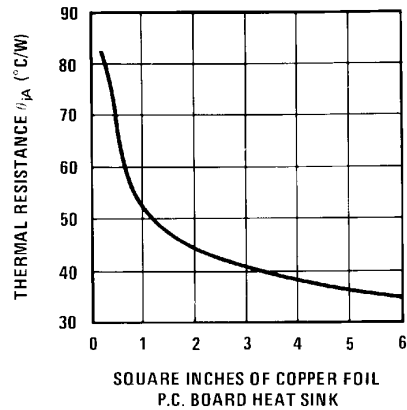

00784311

**Supply Decoupling vs Frequency**

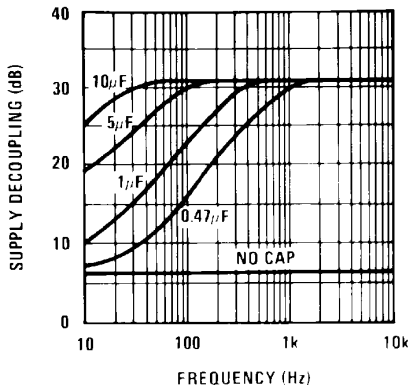

00784312

**Total Harmonic Distortion vs Output Power**

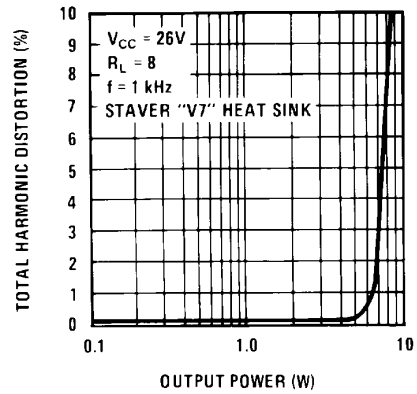

00784313

**Output Voltage Gain vs Frequency**

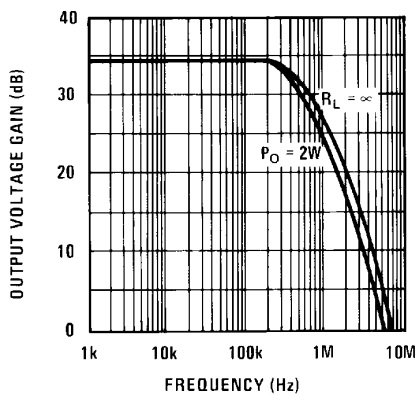

00784314

**Total Harmonic Distortion vs Frequency**

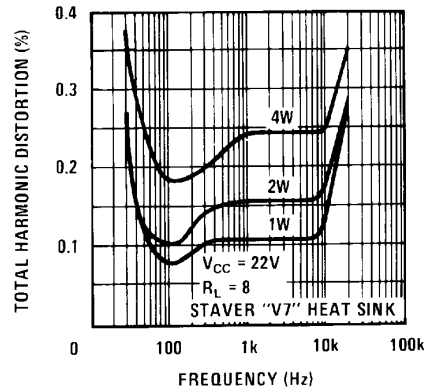

00784315

# Typical Performance Characteristics (Continued)

Power Supply Current vs Supply Voltage

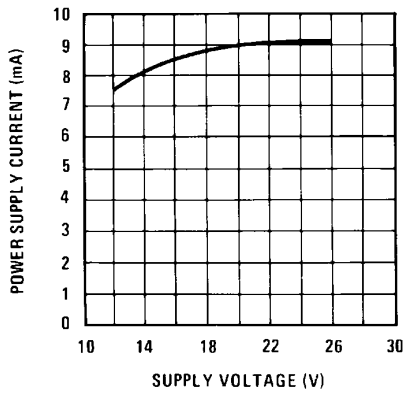

00784316

Device Dissipation vs Output Power—16Ω Load

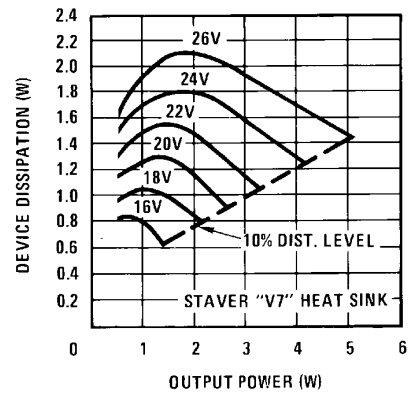

00784317

Device Dissipation vs Output Power—8Ω Load

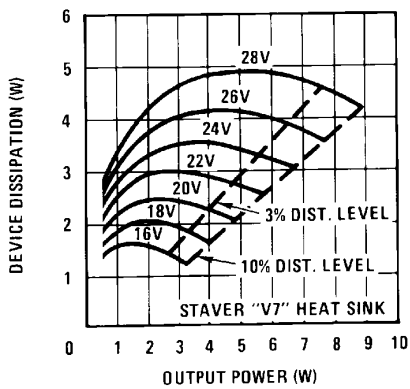

00784318

Device Dissipation vs Output Power—4Ω Load

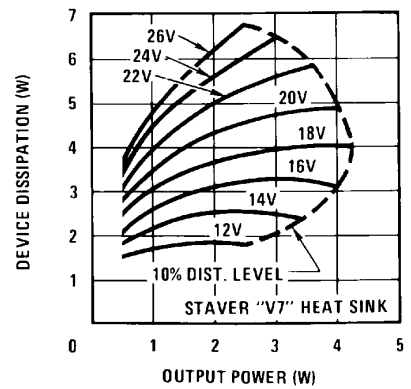

00784319

## Block and Connection Diagrams

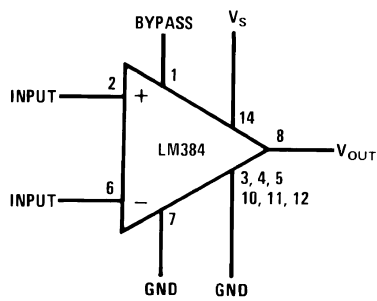

00784301

Dual-In-Line Package

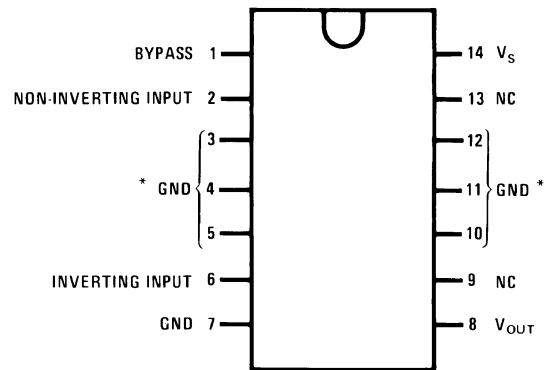

00784302

Note 7: Heatsink Pins

Top View Order Number LM384N See NS Package Number N14A

# Typical Applications

Typical 5W Amplifier

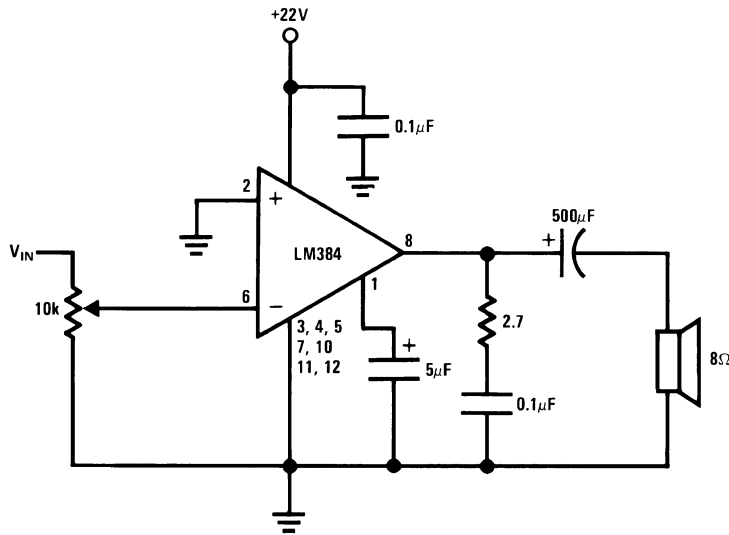

00784306

Bridge Amplifier

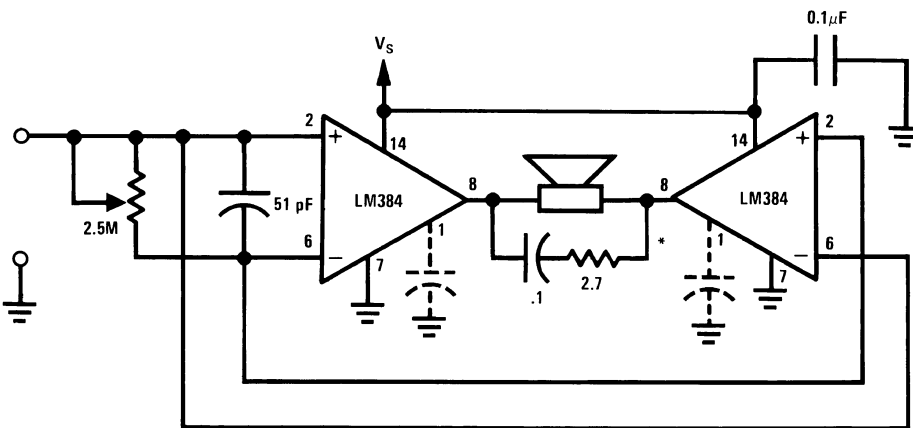

00784307

Intercom

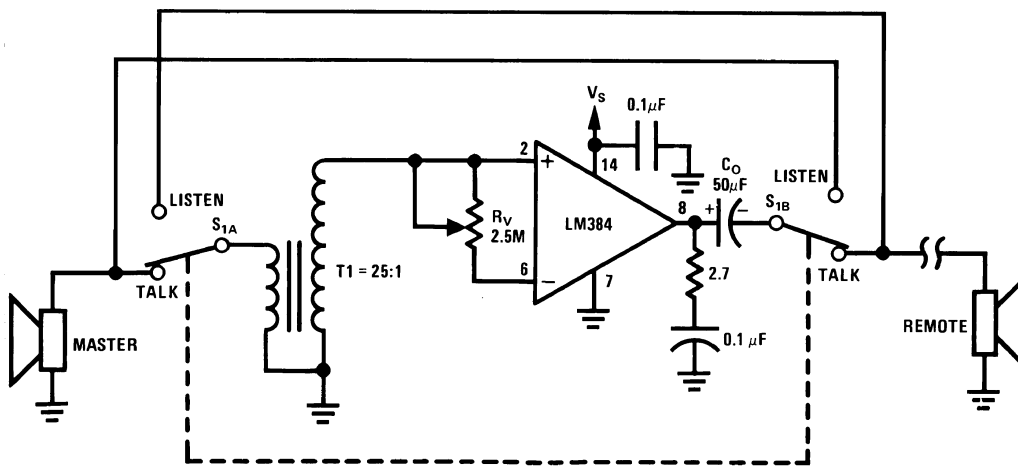

00784308

\*For stability with high current loads

## Typical Applications (Continued)

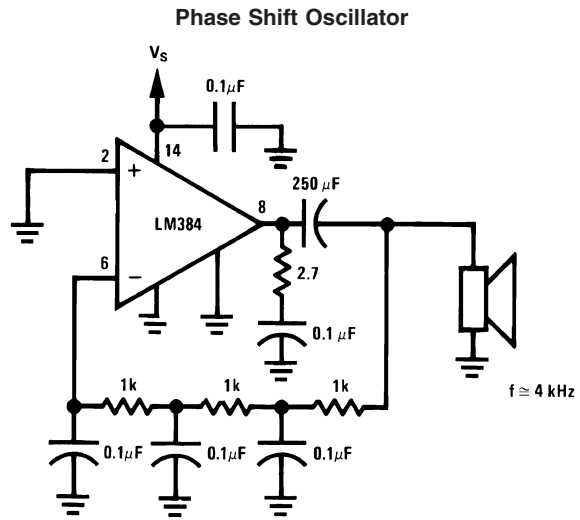

**Physical Dimensions** inches (millimeters) unless otherwise noted

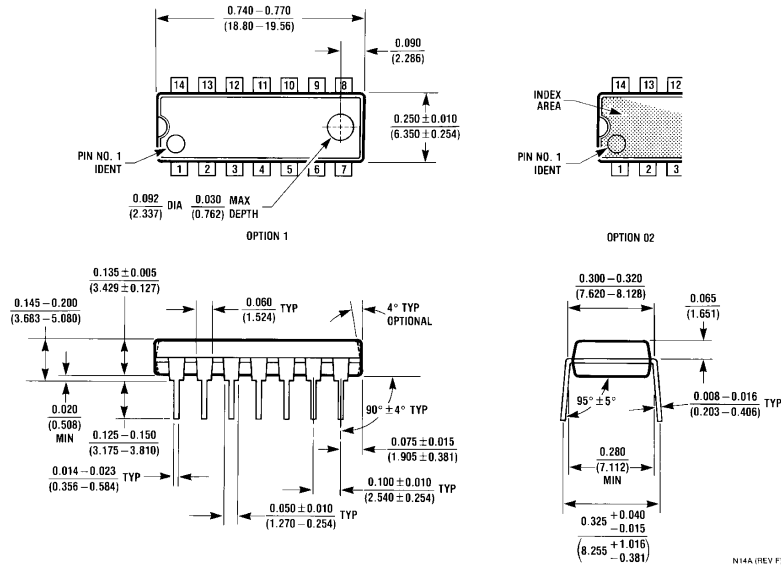

**Molded Dual-In-Line Package (N)**  
**Order Number LM384N**  
**NS Package Number N14A**

National does not assume any responsibility for use of any circuitry described, no circuit patent licenses are implied and National reserves the right at any time without notice to change said circuitry and specifications.

For the most current product information visit us at [www.national.com](http://www.national.com).

**LIFE SUPPORT POLICY**

NATIONAL'S PRODUCTS ARE NOT AUTHORIZED FOR USE AS CRITICAL COMPONENTS IN LIFE SUPPORT DEVICES OR SYSTEMS WITHOUT THE EXPRESS WRITTEN APPROVAL OF THE PRESIDENT AND GENERAL COUNSEL OF NATIONAL SEMICONDUCTOR CORPORATION. As used herein:

1. Life support devices or systems are devices or systems which, (a) are intended for surgical implant into the body, or (b) support or sustain life, and whose failure to perform when properly used in accordance with instructions for use provided in the labeling, can be reasonably expected to result in a significant injury to the user.
2. A critical component is any component of a life support device or system whose failure to perform can be reasonably expected to cause the failure of the life support device or system, or to affect its safety or effectiveness.

**BANNED SUBSTANCE COMPLIANCE**

National Semiconductor certifies that the products and packing materials meet the provisions of the Customer Products Stewardship Specification (CSP-9-111C2) and the Banned Substances and Materials of Interest Specification (CSP-9-111S2) and contain no "Banned Substances" as defined in CSP-9-111S2.



**National Semiconductor**  
**Americas Customer Support Center**  
 Email: [new.feedback@nsc.com](mailto:new.feedback@nsc.com)  
 Tel: 1-800-272-9959

**National Semiconductor**  
**Europe Customer Support Center**  
 Fax: +49 (0) 180-530 85 86  
 Email: [europe.support@nsc.com](mailto:europe.support@nsc.com)  
 Deutsch Tel: +49 (0) 69 9508 6208  
 English Tel: +44 (0) 870 24 0 2171  
 Français Tel: +33 (0) 1 41 91 8790

**National Semiconductor**  
**Asia Pacific Customer Support Center**  
 Email: [ap.support@nsc.com](mailto:ap.support@nsc.com)

**National Semiconductor**  
**Japan Customer Support Center**  
 Fax: 81-3-5639-7507  
 Email: [jpn.feedback@nsc.com](mailto:jpn.feedback@nsc.com)  
 Tel: 81-3-5639-7560

[www.national.com](http://www.national.com)