

CBTD3306

Dual bus switch with level shifting

Rev. 04 — 25 March 2010

Product data sheet

1. General description

The CBTD3306 dual FET bus switch features independent line switches. Each switch is disabled when the associated output enable (\overline{nOE}) input is HIGH.

The CBTD3306 is characterized for operation from $-40\text{ }^{\circ}\text{C}$ to $+85\text{ }^{\circ}\text{C}$.

2. Features and benefits

- Designed to be used in 5 V to 3.3 V level shifting applications with internal diode
- $5\ \Omega$ switch connection between two ports
- TTL-compatible input levels
- Multiple package options
- Latch-up protection exceeds 100 mA per JESD78B
- ESD protection:
 - ◆ HBM JESD22-A114F exceeds 2000 V
 - ◆ CDM JESD22-C101E exceeds 1000 V

3. Ordering information

Table 1. Ordering information

Type number	Package		
	Name	Description	Version
CBTD3306D	SO8	plastic small outline package; 8 leads; body width 3.9 mm	SOT96-1
CBTD3306PW	TSSOP8	plastic thin shrink small outline package; 8 leads; body width 4.4 mm	SOT530-1
CBTD3306GT	XSON8	plastic extremely thin small outline package; no leads; 8 terminals; body $1 \times 1.95 \times 0.5$ mm	SOT833-1
CBTD3306GM	XQFN8U	plastic extremely thin quad flat package; no leads; 8 terminals; body $1.6 \times 1.6 \times 0.5$ mm	SOT902-1

4. Marking

Table 2. Marking codes

Type number	Marking code
CBTD3306D	W06
CBTD3306PW	W06
CBTD3306GT	W06
CBTD3306GM	W06



5. Functional diagram

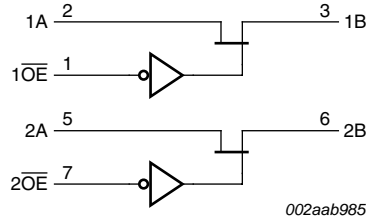

Fig 1. Logic diagram

6. Pinning information

6.1 Pinning

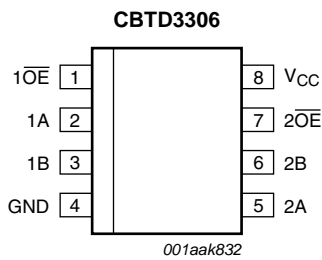

Fig 2. Pin configuration for SO8 (SOT96-1)

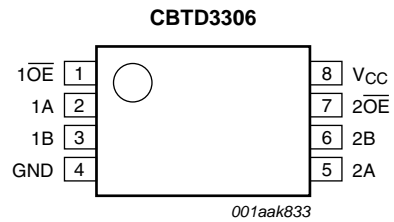

Fig 3. Pin configuration for TSSOP8 (SOT530-1)

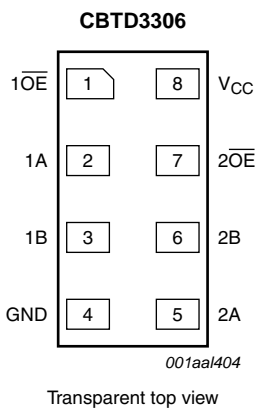

Fig 4. Pin configuration SOT833-1 (XSON8)

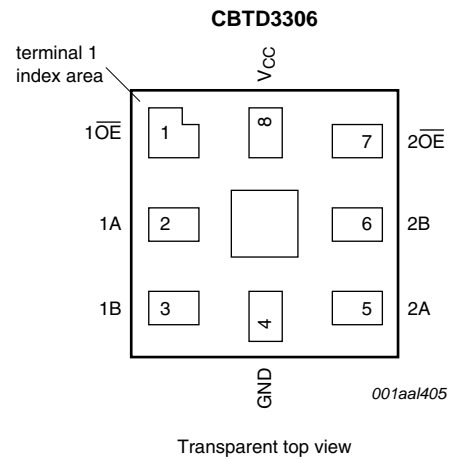

Fig 5. Pin configuration SOT902-1 (XQFN8U)

6.2 Pin description

Table 3. Pin description

Symbol	Pin	Description
$1\overline{OE}, 2\overline{OE}$	1, 7	output enable input
1A, 2A	2, 5	data input/output (A port)
1B, 2B	3, 6	data input/output (B port)
GND	4	ground (0 V)
V_{CC}	8	positive supply voltage

7. Functional description

Table 4. Function selection^[1]

Input	Input/output
\overline{nOE}	nA, nB
L	nA = nB
H	Z

[1] H = HIGH voltage level; L = LOW voltage level; Z = high-impedance OFF-state.

8. Limiting values

Table 5. Limiting values

In accordance with the Absolute Maximum Rating System (IEC 60134).^[1]

$T_{amb} = -40\text{ }^{\circ}\text{C}$ to $+85\text{ }^{\circ}\text{C}$, unless otherwise specified.

Symbol	Parameter	Conditions	Min	Max	Unit
V_{CC}	supply voltage		-0.5	+7.0	V
V_I	input voltage		^[2] -0.5	+7.0	V
I_{SW}	switch current		-	128	mA
I_{IK}	input clamping current	$V_{IO} = 0\text{ V}$	-50	-	mA
T_{stg}	storage temperature		-65	+150	$^{\circ}\text{C}$

[1] Stresses beyond those listed may cause permanent damage to the device. These are stress ratings only and functional operation of the device at these or any other conditions beyond those indicated under [Section 9](#), is not implied. Exposure to absolute-maximum-rated conditions for extended periods may affect device reliability.

[2] The input and output negative-voltage ratings may be exceeded if the input and output clamp-current ratings are observed.

9. Recommended operating conditions

Table 6. Operating conditions

All unused control inputs of the device must be held at V_{CC} or GND to ensure proper device operation.

Symbol	Parameter	Conditions	Min	Typ	Max	Unit
V_{CC}	supply voltage		4.5	-	5.5	V
V_{IH}	HIGH-level input voltage		2.0	-	-	V
V_{IL}	LOW-level input voltage		-	-	0.8	V
T_{amb}	ambient temperature	operating in free air	-40	-	+85	$^{\circ}\text{C}$

10. Static characteristics

Table 7. Static characteristics

Voltages are referenced to GND (ground = 0 V).

Symbol	Parameter	Conditions	T _{amb} = -40 °C to +85 °C			Unit	
			Min	Typ ^[1]	Max		
V _{IK}	input clamping voltage	V _{CC} = 4.5 V; I _I = -18 mA	-	-	-1.2	V	
I _I	input leakage current	V _{CC} = 5.5 V; V _I = GND or 5.5 V	-	-	±1	μA	
I _{CC}	supply current	V _{CC} = 5.5 V; I _{SW} = 0 mA; V _I = V _{CC} or GND	-	-	1.5	mA	
V _{pass}	pass voltage	see Figure 6 to Figure 10	-	-	-	V	
ΔI _{CC}	additional supply current	per input pin; V _{CC} = 5.5 V; one input at 3.4 V, other inputs at V _{CC} or GND	^[2]	-	2.5	mA	
C _I	input capacitance	control pin; V _I = 3 V or 0 V	-	3.2	-	pF	
C _{io(off)}	off-state input/output capacitance	port off; V _I = 3 V or 0 V; $\overline{nOE} = V_{CC}$	-	6.5	-	pF	
R _{ON}	ON resistance	V _{CC} = 4.5 V; V _I = 0 V; I _I = 64 mA	^[3]	-	3.6	5	Ω
		V _{CC} = 4.5 V; V _I = 0 V; I _I = 30 mA	^[3]	-	3.6	5	Ω
		V _{CC} = 4.5 V; V _I = 2.4 V; I _I = 15 mA	^[3]	-	17	35	Ω

[1] All typical values are at V_{CC} = 5 V, T_{amb} = 25 °C.

[2] This is the increase in supply current for each input that is at the specified TTL voltage level rather than V_{CC} or GND.

[3] Measured by the voltage drop between the nA and the nB terminals at the indicated current through the switch. ON resistance is determined by the lowest voltage of the two (nA or nB) terminals.

10.1 Typical pass voltage graphs

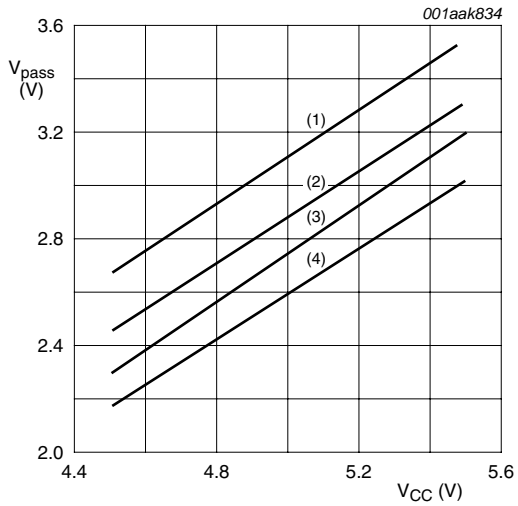

- (1) $I_{SW} = 100 \mu A$
- (2) $I_{SW} = 6 \text{ mA}$
- (3) $I_{SW} = 12 \text{ mA}$
- (4) $I_{SW} = 24 \text{ mA}$

Fig 6. Pass voltage versus supply voltage; $T_{amb} = 85 \text{ }^\circ\text{C}$ (typical)

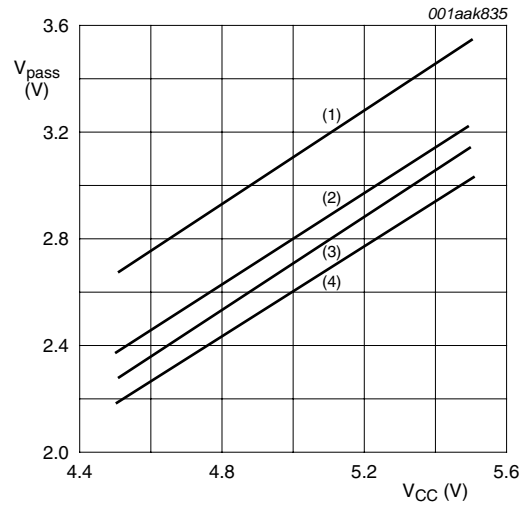

- (1) $I_{SW} = 100 \mu A$
- (2) $I_{SW} = 6 \text{ mA}$
- (3) $I_{SW} = 12 \text{ mA}$
- (4) $I_{SW} = 24 \text{ mA}$

Fig 7. Pass voltage versus supply voltage; $T_{amb} = 70 \text{ }^\circ\text{C}$ (typical)

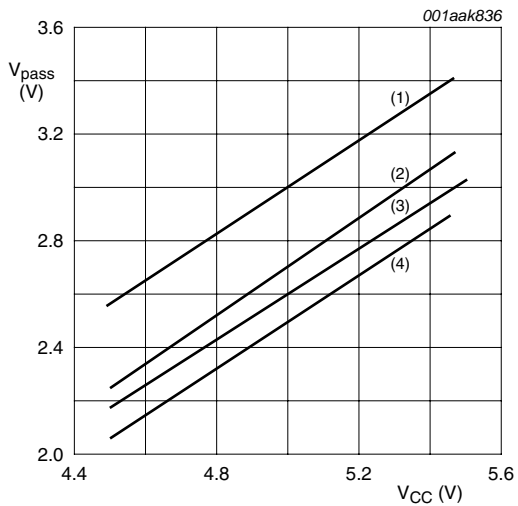

- (1) $I_{SW} = 100 \mu A$
- (2) $I_{SW} = 6 \text{ mA}$
- (3) $I_{SW} = 12 \text{ mA}$
- (4) $I_{SW} = 24 \text{ mA}$

Fig 8. Pass voltage versus supply voltage; $T_{amb} = 25 \text{ }^\circ\text{C}$ (typical)

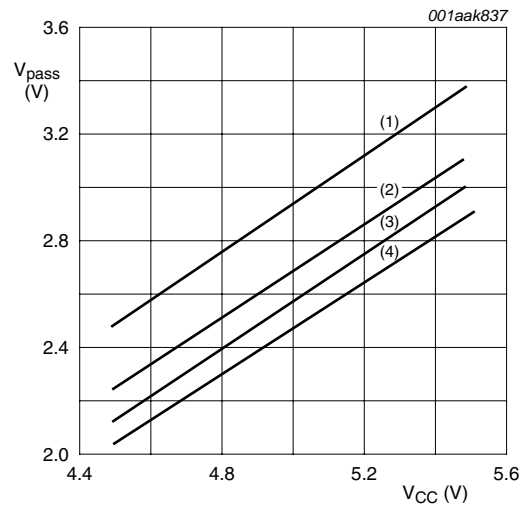

- (1) $I_{SW} = 100 \mu A$
- (2) $I_{SW} = 6 \text{ mA}$
- (3) $I_{SW} = 12 \text{ mA}$
- (4) $I_{SW} = 24 \text{ mA}$

Fig 9. Pass voltage versus supply voltage; $T_{amb} = 0 \text{ }^\circ\text{C}$ (typical)

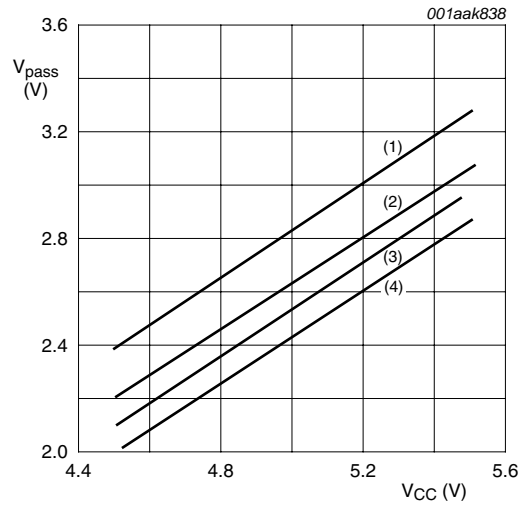

- (1) I_{SW} = 100 µA
- (2) I_{SW} = 6 mA
- (3) I_{SW} = 12 mA
- (4) I_{SW} = 24 mA

Fig 10. Pass voltage versus supply voltage; T_{amb} = -40 °C (typical)

11. Dynamic characteristics

Table 8. Dynamic characteristics

Voltages are referenced to GND (ground = 0 V). For test circuit see [Figure 13](#).

Symbol	Parameter	Conditions	T _{amb} = -40 °C to +85 °C			Unit	
			Min	Typ	Max		
t _{pd}	propagation delay	nA, nB to nB, nA; see Figure 11 V _{CC} = 5.0 V ± 0.5 V	[1][2]	-	-	0.25	ns
t _{en}	enable time	nOE to nA or nB; see Figure 12 V _{CC} = 5.0 V ± 0.5 V	[2]	1.0	-	5.4	ns
t _{dis}	disable time	nOE to nA or nB; see Figure 12 V _{CC} = 5.0 V ± 0.5 V	[2]	1.0	-	4.9	ns

- [1] The propagation delay is the calculated RC time constant of the typical ON resistance of the switch and the specified load capacitance, when driven by an ideal voltage source (zero output impedance).
- [2] t_{pd} is the same as t_{PLH} and t_{PHL}.
t_{en} is the same as t_{PZL} and t_{PZH}.
t_{dis} is the same as t_{PLZ} and t_{PHZ}.

12. Waveforms

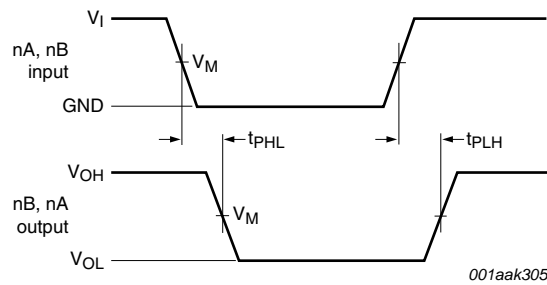

Measurement points are given in [Table 9](#).

Logic levels: V_{OL} and V_{OH} are typical output voltage levels that occur with the output load.

Fig 11. The data input (nA, nB) to output (nB, nA) propagation delay times

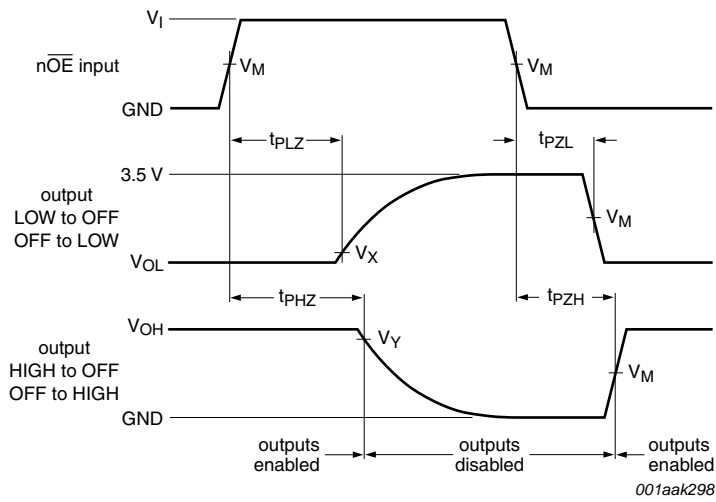

Measurement points are given in [Table 9](#).
 Logic levels: V_{OL} and V_{OH} are typical output voltage levels that occur with the output load.

Fig 12. Enable and disable times

Table 9. Measurement points

Supply voltage	Input		Output		
V_{CC}	V_I	V_M	V_M	V_X	V_Y
$V_{CC} = 5.0\text{ V} \pm 0.5\text{ V}$	GND to 3.0 V	1.5 V	1.5 V	$V_{OL} + 0.3\text{ V}$	$V_{OH} - 0.3\text{ V}$

13. Test information

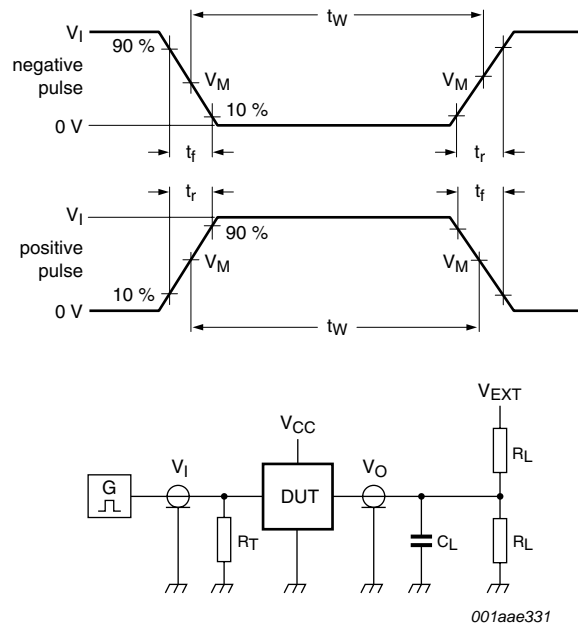

Test data is given in [Table 10](#).

All input pulses are supplied by generators having the following characteristics: PRR ≤ 10 MHz; Z_o = 50 Ω.

The outputs are measured one at a time with one transition per measurement.

Definitions for test circuit:

R_L = Load resistance.

C_L = Load capacitance including jig and probe capacitance.

R_T = Termination resistance should be equal to output impedance Z_o of the pulse generator.

V_{EXT} = External voltage for measuring switching times.

Fig 13. Test circuit for measuring switching times

Table 10. Test data

Supply voltage	Input		Load		V _{EXT}		
	V _I	t _r , t _f	C _L	R _L	t _{PLH} , t _{PHL}	t _{PLZ} , t _{PZL}	t _{PHZ} , t _{PZH}
V _{CC} = 5.0 V ± 0.5 V	GND to 3.0 V	≤ 2.5 ns	50 pF	500 Ω	open	7.0 V	open

14. Package outline

SO8: plastic small outline package; 8 leads; body width 3.9 mm

SOT96-1

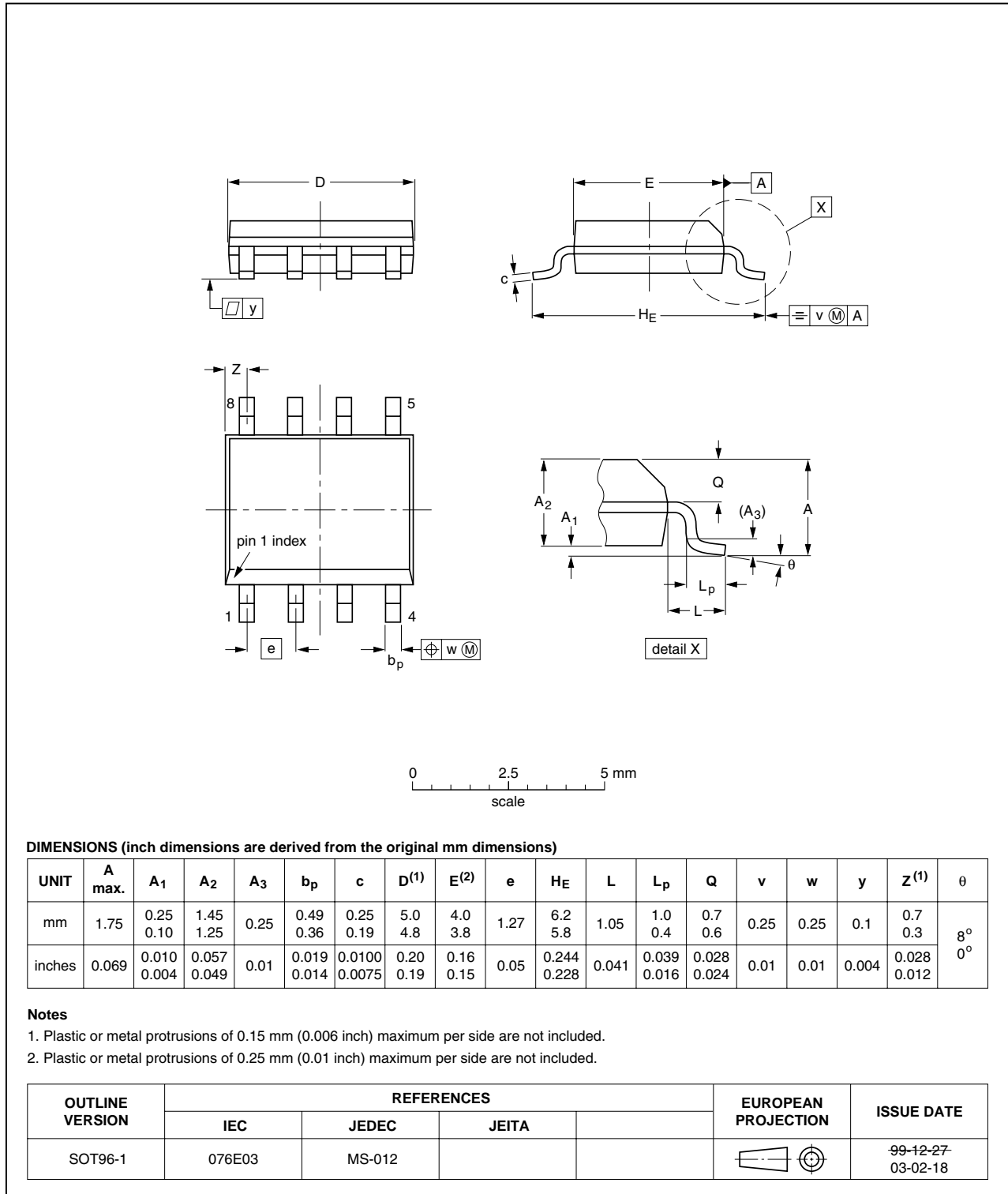

Fig 14. Package outline SOT96-1 (SO8)

TSSOP8: plastic thin shrink small outline package; 8 leads; body width 4.4 mm

SOT530-1

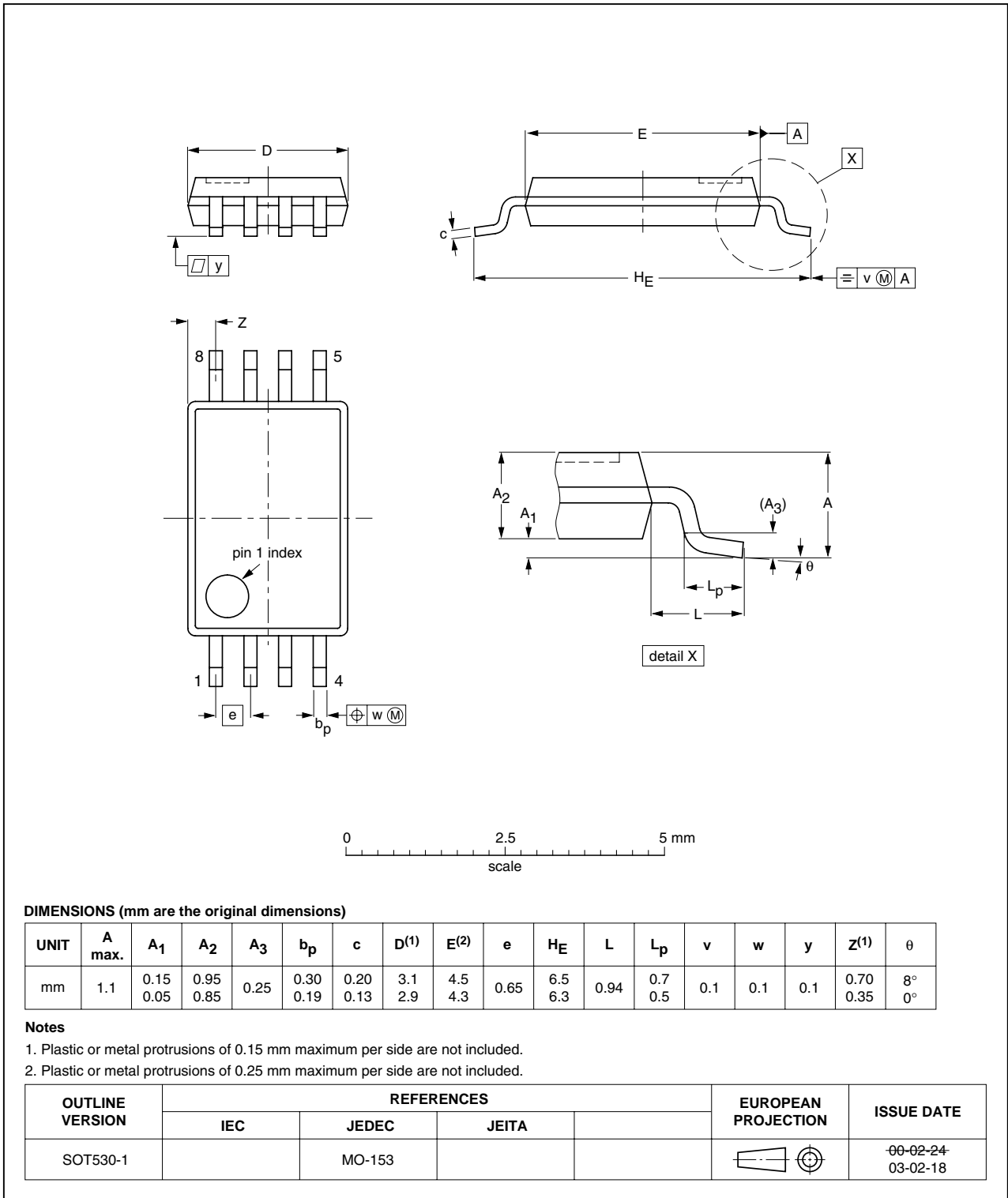

Fig 15. Package outline SOT530-1 (TSSOP8)

XSON8: plastic extremely thin small outline package; no leads; 8 terminals; body 1 x 1.95 x 0.5 mm

SOT833-1

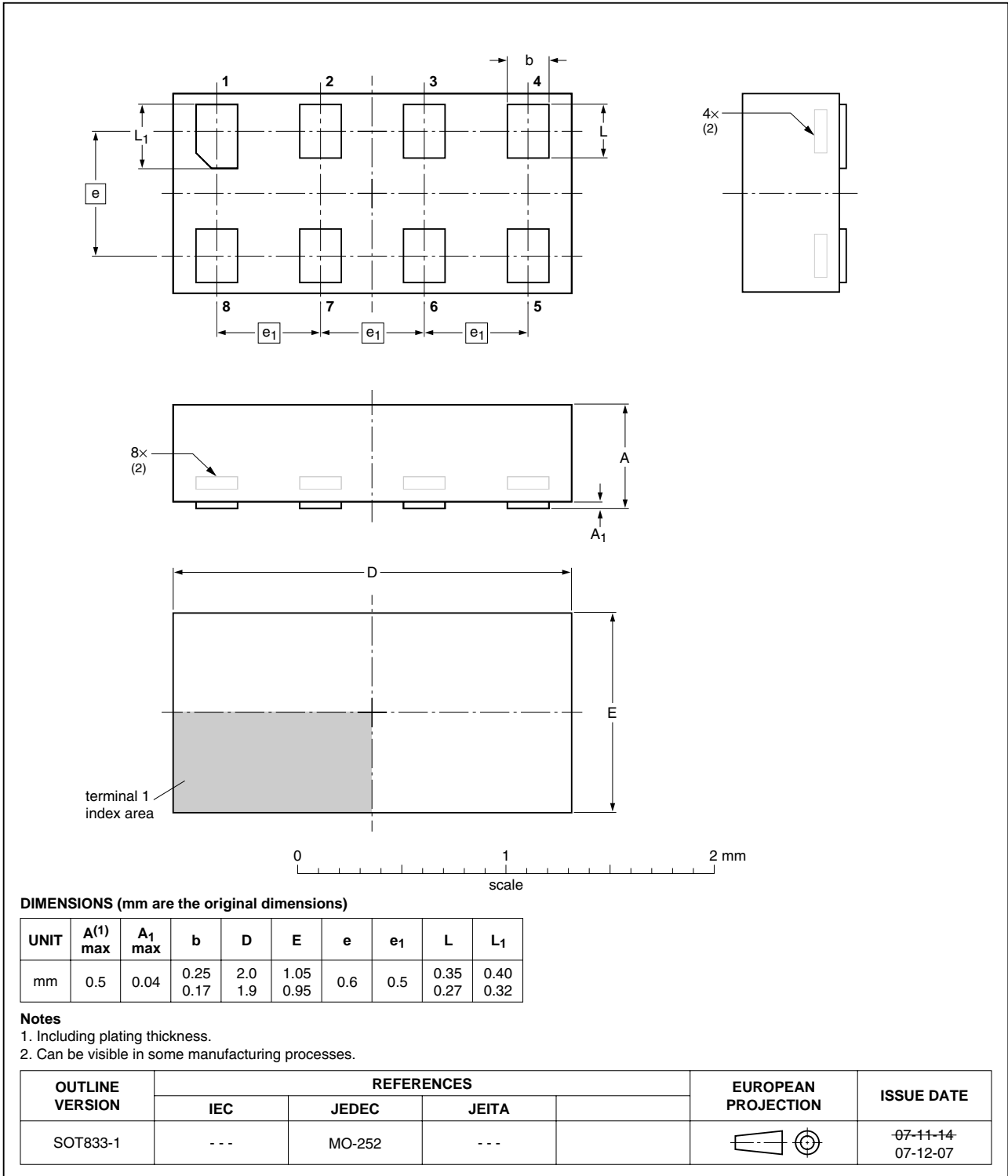

Fig 16. Package outline SOT833-1 (XSON8)

XQFN8U: plastic extremely thin quad flat package; no leads; 8 terminals; UTLP based; body 1.6 x 1.6 x 0.5 mm

SOT902-1

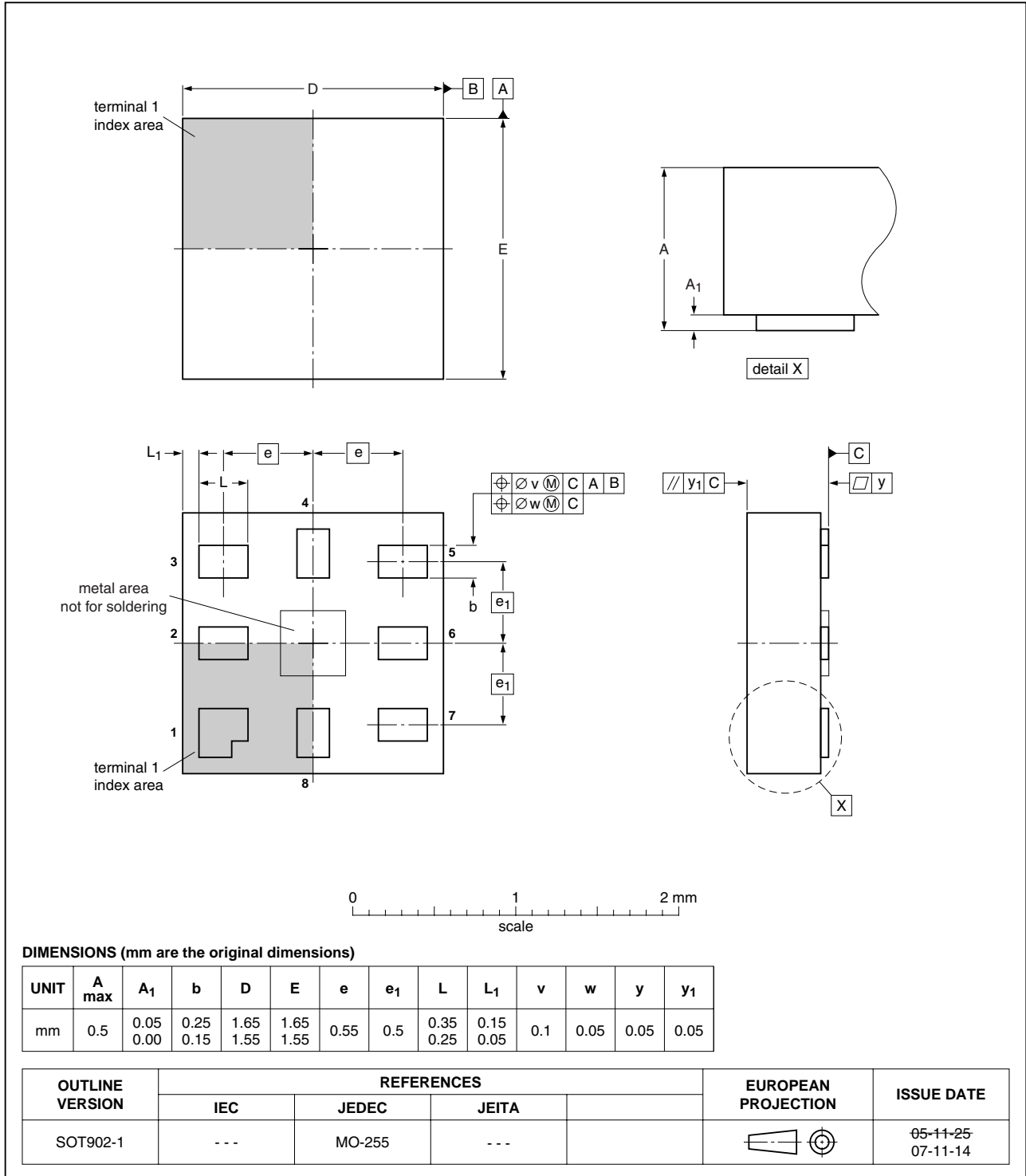

Fig 17. Package outline SOT902-1 (XQFN8U)

15. Abbreviations

Table 11. Abbreviations

Acronym	Description
CDM	Charged Device Model
ESD	ElectroStatic Discharge
FET	Field Effect Transistor
HBM	Human Body Model
PRR	Pulse Rate Repetition
TTL	Transistor-Transistor Logic

16. Revision history

Table 12. Revision history

Document ID	Release date	Data sheet status	Change notice	Supersedes
CBTD3306_4	20100325	Product data sheet	-	CBTD3306_3
CBTD3306_3	20100223	Product data sheet	-	CBTD3306_2
Modifications:		<ul style="list-style-type: none"> Added type number CBTD3306GT (XSON8/SOT833-1 package). Added type number CBTD3306GM (XQFN8U/SOT902-1 package). Table 2: Marking code table added. 		
CBTD3306_2	20091015	Product data sheet	-	CBTD3306_1
CBTD3306_1	20011108	Product data	-	-

17. Legal information

17.1 Data sheet status

Document status ^{[1][2]}	Product status ^[3]	Definition
Objective [short] data sheet	Development	This document contains data from the objective specification for product development.
Preliminary [short] data sheet	Qualification	This document contains data from the preliminary specification.
Product [short] data sheet	Production	This document contains the product specification.

[1] Please consult the most recently issued document before initiating or completing a design.

[2] The term 'short data sheet' is explained in section "Definitions".

[3] The product status of device(s) described in this document may have changed since this document was published and may differ in case of multiple devices. The latest product status information is available on the Internet at URL <http://www.nxp.com>.

17.2 Definitions

Draft — The document is a draft version only. The content is still under internal review and subject to formal approval, which may result in modifications or additions. NXP Semiconductors does not give any representations or warranties as to the accuracy or completeness of information included herein and shall have no liability for the consequences of use of such information.

Short data sheet — A short data sheet is an extract from a full data sheet with the same product type number(s) and title. A short data sheet is intended for quick reference only and should not be relied upon to contain detailed and full information. For detailed and full information see the relevant full data sheet, which is available on request via the local NXP Semiconductors sales office. In case of any inconsistency or conflict with the short data sheet, the full data sheet shall prevail.

Product specification — The information and data provided in a Product data sheet shall define the specification of the product as agreed between NXP Semiconductors and its customer, unless NXP Semiconductors and customer have explicitly agreed otherwise in writing. In no event however, shall an agreement be valid in which the NXP Semiconductors product is deemed to offer functions and qualities beyond those described in the Product data sheet.

17.3 Disclaimers

Limited warranty and liability — Information in this document is believed to be accurate and reliable. However, NXP Semiconductors does not give any representations or warranties, expressed or implied, as to the accuracy or completeness of such information and shall have no liability for the consequences of use of such information.

In no event shall NXP Semiconductors be liable for any indirect, incidental, punitive, special or consequential damages (including - without limitation - lost profits, lost savings, business interruption, costs related to the removal or replacement of any products or rework charges) whether or not such damages are based on tort (including negligence), warranty, breach of contract or any other legal theory.

Notwithstanding any damages that customer might incur for any reason whatsoever, NXP Semiconductors' aggregate and cumulative liability towards customer for the products described herein shall be limited in accordance with the *Terms and conditions of commercial sale* of NXP Semiconductors.

Right to make changes — NXP Semiconductors reserves the right to make changes to information published in this document, including without limitation specifications and product descriptions, at any time and without notice. This document supersedes and replaces all information supplied prior to the publication hereof.

Suitability for use in automotive applications — This NXP Semiconductors product has been qualified for use in automotive applications. The product is not designed, authorized or warranted to be

suitable for use in medical, military, aircraft, space or life support equipment, nor in applications where failure or malfunction of an NXP Semiconductors product can reasonably be expected to result in personal injury, death or severe property or environmental damage. NXP Semiconductors accepts no liability for inclusion and/or use of NXP Semiconductors products in such equipment or applications and therefore such inclusion and/or use is at the customer's own risk.

Applications — Applications that are described herein for any of these products are for illustrative purposes only. NXP Semiconductors makes no representation or warranty that such applications will be suitable for the specified use without further testing or modification.

NXP Semiconductors does not accept any liability related to any default, damage, costs or problem which is based on a weakness or default in the customer application/use or the application/use of customer's third party customer(s) (hereinafter both referred to as "Application"). It is customer's sole responsibility to check whether the NXP Semiconductors product is suitable and fit for the Application planned. Customer has to do all necessary testing for the Application in order to avoid a default of the Application and the product. NXP Semiconductors does not accept any liability in this respect.

Limiting values — Stress above one or more limiting values (as defined in the Absolute Maximum Ratings System of IEC 60134) will cause permanent damage to the device. Limiting values are stress ratings only and (proper) operation of the device at these or any other conditions above those given in the Recommended operating conditions section (if present) or the Characteristics sections of this document is not warranted. Constant or repeated exposure to limiting values will permanently and irreversibly affect the quality and reliability of the device.

Terms and conditions of commercial sale — NXP Semiconductors products are sold subject to the general terms and conditions of commercial sale, as published at <http://www.nxp.com/profile/terms>, unless otherwise agreed in a valid written individual agreement. In case an individual agreement is concluded only the terms and conditions of the respective agreement shall apply. NXP Semiconductors hereby expressly objects to applying the customer's general terms and conditions with regard to the purchase of NXP Semiconductors products by customer.

No offer to sell or license — Nothing in this document may be interpreted or construed as an offer to sell products that is open for acceptance or the grant, conveyance or implication of any license under any copyrights, patents or other industrial or intellectual property rights.

Export control — This document as well as the item(s) described herein may be subject to export control regulations. Export might require a prior authorization from national authorities.

17.4 Trademarks

Notice: All referenced brands, product names, service names and trademarks are the property of their respective owners.

18. Contact information

For more information, please visit: <http://www.nxp.com>

For sales office addresses, please send an email to: salesaddresses@nxp.com

19. Contents

1 **General description** 1

2 **Features and benefits** 1

3 **Ordering information** 1

4 **Marking** 1

5 **Functional diagram** 2

6 **Pinning information** 2

6.1 Pinning 2

6.2 Pin description 3

7 **Functional description** 3

8 **Limiting values** 3

9 **Recommended operating conditions** 3

10 **Static characteristics** 4

10.1 Typical pass voltage graphs 5

11 **Dynamic characteristics** 7

12 **Waveforms** 7

13 **Test information** 9

14 **Package outline** 10

15 **Abbreviations** 14

16 **Revision history** 14

17 **Legal information** 15

17.1 Data sheet status 15

17.2 Definitions 15

17.3 Disclaimers 15

17.4 Trademarks 15

18 **Contact information** 16

19 **Contents** 17

Please be aware that important notices concerning this document and the product(s) described herein, have been included in section 'Legal information'.

© NXP B.V. 2010. All rights reserved.

For more information, please visit: <http://www.nxp.com>
 For sales office addresses, please send an email to: salesaddresses@nxp.com

Date of release: 25 March 2010
 Document identifier: CBTD3306_4