

## BCD TO DECIMAL DECODER

- BCD TO DECIMAL DECODING OR BINARY TO OCTAL DECODING
- HIGH DECODED OUTPUT DRIVE CAPABILITY
- "POSITIVE LOGIC" INPUTS AND OUTPUTS: DECODED OUTPUTS GO HIGH ON SELECTION
- MEDIUM SPEED OPERATION :  $t_{PHL}$ ,  $t_{PLH}$  = 80ns (Typ.) at  $V_{DD} = 10V$
- QUIESCENT CURRENT SPECIF. UP TO 20V
- STANDARDIZED SYMMETRICAL OUTPUT CHARACTERISTICS
- INPUT LEAKAGE CURRENT  
 $I_l = 100nA$  (MAX) AT  $V_{DD} = 18V$   $T_A = 25^\circ C$
- 100% TESTED FOR QUIESCENT CURRENT
- MEETS ALL REQUIREMENTS OF JEDEC JESD13B "STANDARD SPECIFICATIONS FOR DESCRIPTION OF B SERIES CMOS DEVICES"

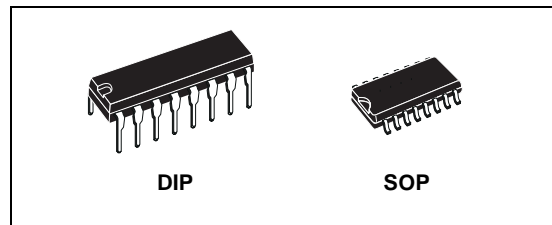

### ORDER CODES

PACKAGE	TUBE	T & R
DIP	HCF4028BEY	
SOP	HCF4028BM1	HCF4028M013TR

inputs, decoding logic gates, and 10 output buffers.

A BCD code applied to the four inputs, A to D, results in a high level at the selected one of 10 decimal decoded outputs. Similarly, a 3-bit binary code applied to inputs A through C is decoded in octal code at output 0 to 7 if D = "0". High drive capability is provided at all outputs to enhance dc and dynamic performance in high fan-out applications.

### DESCRIPTION

HCF4028B is a monolithic integrated circuit fabricated in Metal Oxide Semiconductor technology available in DIP and SOP packages. HCF4028B is a BCD to DECIMAL or BINARY to OCTAL decoder consisting of buffering on all 4

### PIN CONNECTION

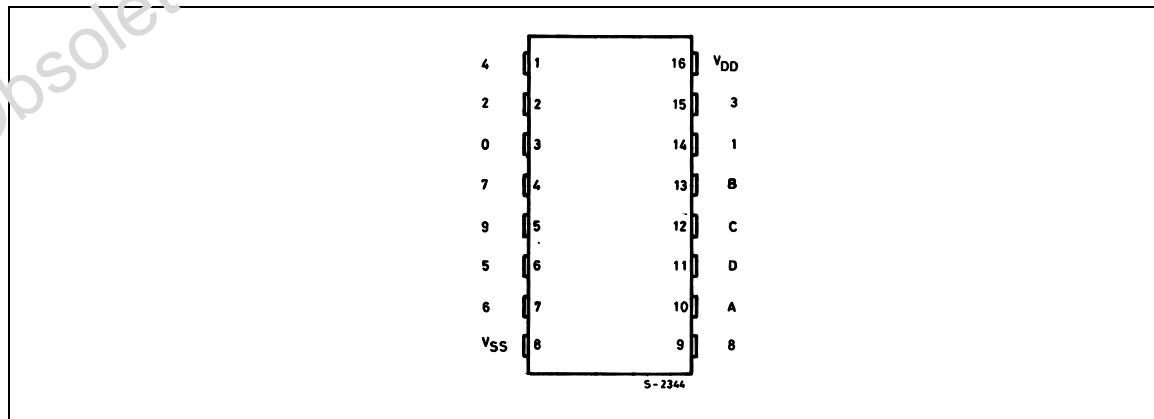

# HCF4028B

## INPUT EQUIVALENT CIRCUIT

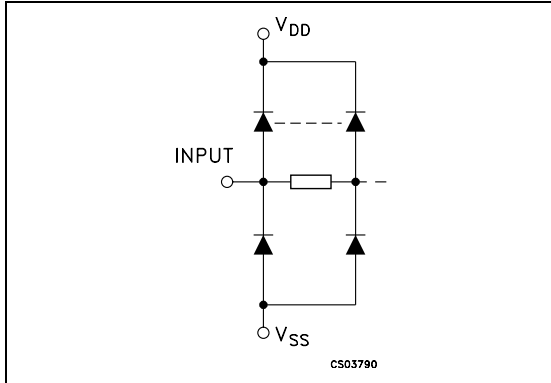

## PIN DESCRIPTION

PIN No	SYMBOL	NAME AND FUNCTION
10, 13, 12, 11	A, B, C, D	BCD Data Inputs
10, 13, 12	A, B, C	3-Bit Binary Inputs
3, 14, 2, 15, 1, 6, 7, 4, 9, 5	0 to 9	Buffered DECIMAL Decoded Outputs
3, 14, 2, 15, 1, 6, 7, 4	0 to 7	Buffered OCTAL Decoded Outputs
8	V <sub>SS</sub>	Negative Supply Voltage
16	V <sub>DD</sub>	Positive Supply Voltage

## FUNCTIONAL DIAGRAM

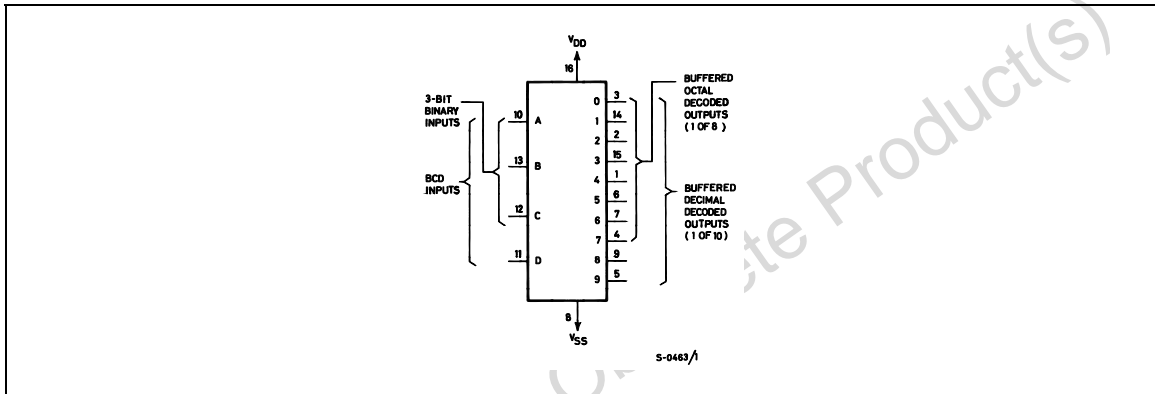

## TRUTH TABLE

INPUTS				OUTPUTS									
D	C	B	A	0	1	2	3	4	5	6	7	8	9
L	L	L	L	H	L	L	L	L	L	L	L	L	L
L	L	L	H	L	H	L	L	L	L	L	L	L	L
L	L	H	L	L	L	H	L	L	L	L	L	L	L
L	L	H	H	L	L	L	H	L	L	L	L	L	L
L	H	L	L	L	L	L	L	H	L	L	L	L	L
L	H	L	H	L	L	L	L	L	H	L	L	L	L
L	H	H	L	L	L	L	L	L	L	H	L	L	L
L	H	H	H	L	L	L	L	L	L	L	H	L	L
H	L	L	L	L	L	L	L	L	L	L	L	H	L
H	L	L	H	L	L	L	L	L	L	L	L	L	H
H	L	H	L	L	L	L	L	L	L	L	L	L	L
H	L	H	H	L	L	L	L	L	L	L	L	L	L
H	H	L	L	L	L	L	L	L	L	L	L	L	L
H	H	L	H	L	L	L	L	L	L	L	L	L	L
H	H	H	L	L	L	L	L	L	L	L	L	L	L
H	H	H	H	L	L	L	L	L	L	L	L	L	L

## LOGIC DIAGRAM

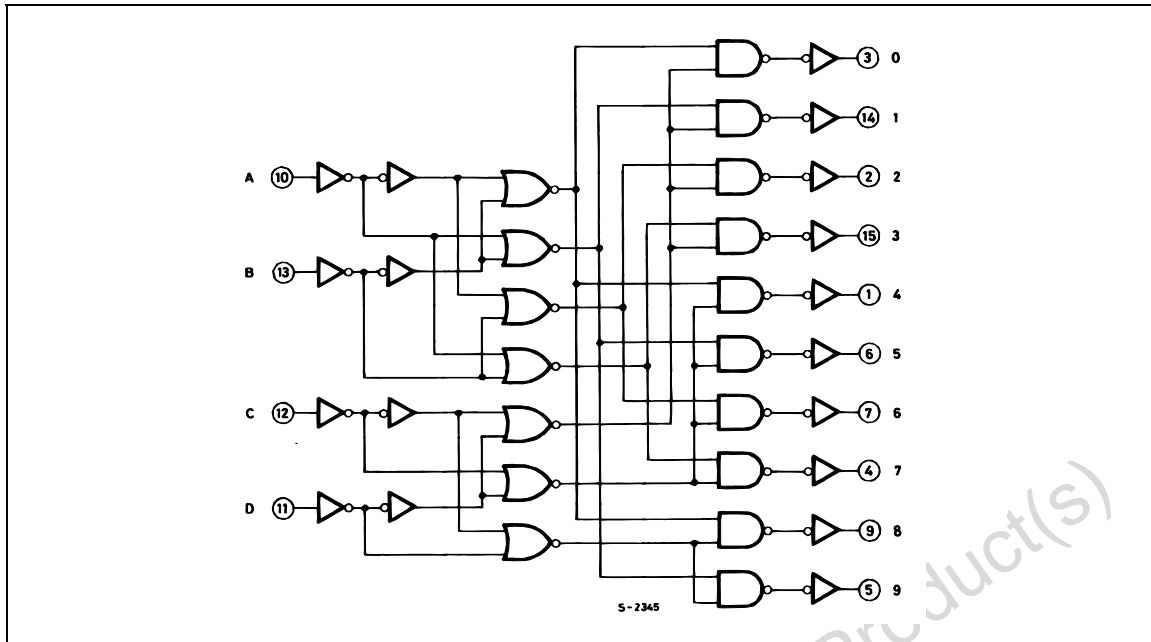

## ABSOLUTE MAXIMUM RATINGS

Symbol	Parameter	Value	Unit
$V_{DD}$	Supply Voltage	-0.5 to +22	V
$V_I$	DC Input Voltage	-0.5 to $V_{DD} + 0.5$	V
$I_I$	DC Input Current	$\pm 10$	mA
$P_D$	Power Dissipation per Package	200	mW
	Power Dissipation per Output Transistor	100	mW
$T_{op}$	Operating Temperature	-55 to +125	$^{\circ}\text{C}$
$T_{stg}$	Storage Temperature	-65 to +150	$^{\circ}\text{C}$

Absolute Maximum Ratings are those values beyond which damage to the device may occur. Functional operation under these conditions is not implied.

All voltage values are referred to  $V_{SS}$  pin voltage.

## RECOMMENDED OPERATING CONDITIONS

Symbol	Parameter	Value	Unit
$V_{DD}$	Supply Voltage	3 to 20	V
$V_I$	Input Voltage	0 to $V_{DD}$	V
$T_{op}$	Operating Temperature	-55 to 125	$^{\circ}\text{C}$

DC SPECIFICATIONS

Symbol	Parameter	Test Conditions				Value						Unit	
		V <sub>I</sub> (V)	V <sub>O</sub> (V)	I <sub>O</sub>   ( $\mu$ A)	V <sub>DD</sub> (V)	T <sub>A</sub> = 25°C			-40 to 85°C		-55 to 125°C		
						Min.	Typ.	Max.	Min.	Max.	Min.		Max.
I <sub>L</sub>	Quiescent Current	0/5			5		0.04	5		150		150	$\mu$ A
		0/10			10		0.04	10		300		300	
		0/15			15		0.04	20		600		600	
		0/20			20		0.08	100		3000		3000	
V <sub>OH</sub>	High Level Output Voltage	0/5		<1	5	4.95			4.95		4.95		V
		0/10		<1	10	9.95			9.95		9.95		
		0/15		<1	15	14.95			14.95		14.95		
V <sub>OL</sub>	Low Level Output Voltage	5/0		<1	5		0.05			0.05		0.05	V
		10/0		<1	10		0.05			0.05		0.05	
		15/0		<1	15		0.05			0.05		0.05	
V <sub>IH</sub>	High Level Input Voltage		0.5/4.5	<1	5	3.5			3.5		3.5		V
			1/9	<1	10	7			7		7		
			1.5/18.5	<1	15	11			11		11		
V <sub>IL</sub>	Low Level Input Voltage		0.5/4.5	<1	5		1.5		1.5		1.5		V
			9/1	<1	10		3		3		3		
			1.5/18.5	<1	15		4		4		4		
I <sub>OH</sub>	Output Drive Current	0/5	2.5		5	-1.36	-3.2		-1.1		-1.1		mA
		0/5	4.6		5	-0.44	-1		-0.36		-0.36		
		0/10	9.5		10	-1.1	-2.6		-0.9		-0.9		
		0/15	13.5		15	-3.0	-6.8		-2.4		-2.4		
I <sub>OL</sub>	Output Sink Current	0/5	0.4		5	0.44	1		0.36		0.36		mA
		0/10	0.5		10	1.1	2.6		0.9		0.9		
		0/15	1.5		15	3.0	6.8		2.4		2.4		
I <sub>I</sub>	Input Leakage Current	0/18	any input		18		$\pm 10^{-5}$	$\pm 0.1$		$\pm 1$		$\pm 1$	$\mu$ A
C <sub>I</sub>	Input Capacitance		any input				5	7.5					pF

The Noise Margin for both "1" and "0" level is: 1V min. with V<sub>DD</sub>=5V, 2V min. with V<sub>DD</sub>=10V, 2.5V min. with V<sub>DD</sub>=15V

DYNAMIC ELECTRICAL CHARACTERISTICS (T<sub>amb</sub> = 25°C, C<sub>L</sub> = 50pF, R<sub>L</sub> = 200K $\Omega$ , t<sub>r</sub> = t<sub>f</sub> = 20 ns)

Symbol	Parameter	Test Condition		Value (*)			Unit
		V <sub>DD</sub> (V)		Min.	Typ.	Max.	
t <sub>PHL</sub> t <sub>PLH</sub>	Propagation Delay Time (Clock to "Out")	5			175	350	ns
		10			80	160	
		15			60	120	
t <sub>rHL</sub> t <sub>rLH</sub>	Transition Time (Carry Out Line)	5			100	200	ns
		10			50	100	
		15			25	50	

(\*) Typical temperature coefficient for all V<sub>DD</sub> value is 0.3 %/°C.

## TEST CIRCUIT

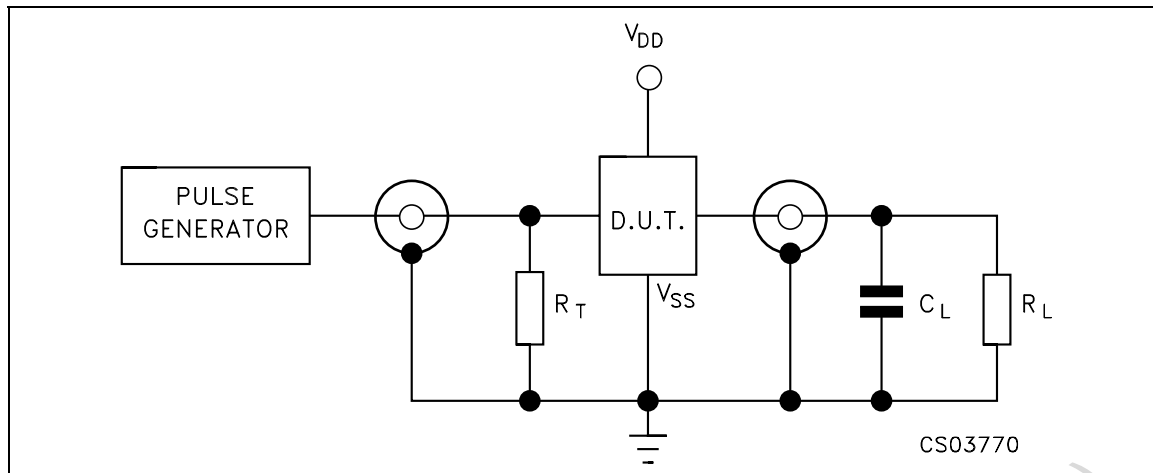

$C_L = 50\text{pF}$  or equivalent (includes jig and probe capacitance)  
 $R_L = 200\text{K}\Omega$   
 $R_T = Z_{\text{OUT}}$  of pulse generator (typically  $50\Omega$ )

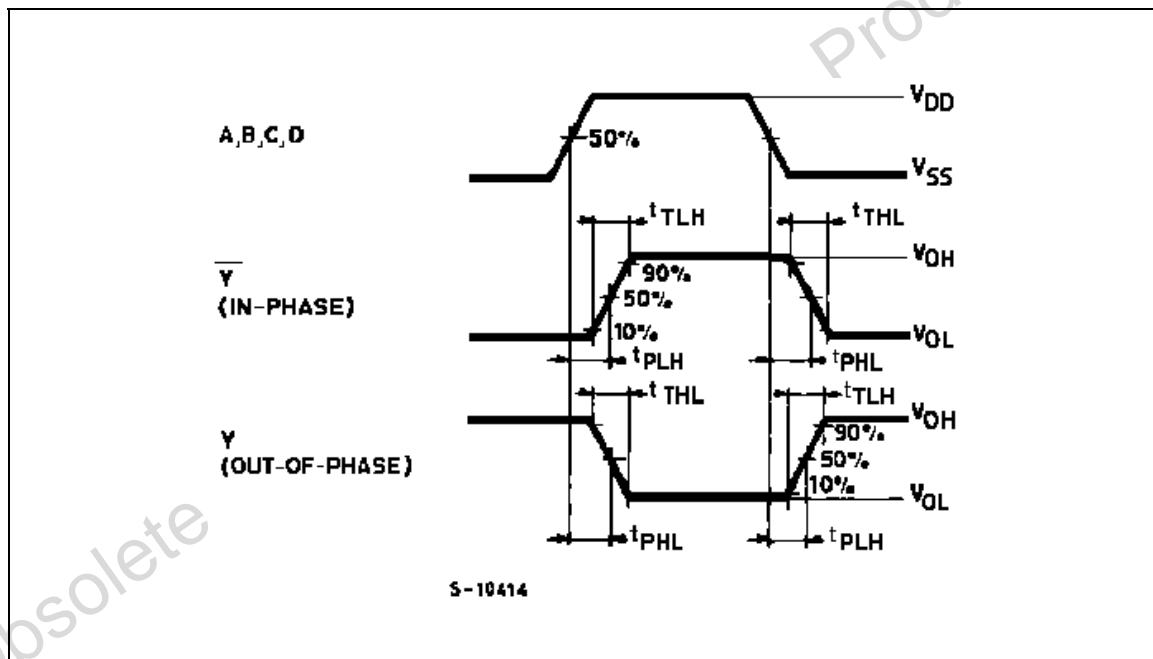
WAVEFORM : PROPAGATION DELAY TIMES ( $f=1\text{MHz}$ ; 50% duty cycle)

## TYPICAL APPLICATION

The circuit shown in fig. 1 converts any 4-bit code to a decimal or hexadecimal code. Fig. 2 shows a number of codes and the decimal or hexadecimal number in these codes, which must be applied to the input pins of HCF4028B to select a particular output. For example: in order to get a "high" on output 8 the input must be either an 8 expressed in

4-bit binary code or a 15 expressed in excess-3code.

# HCF4028B

FIGURE 1 : CODE CONVERSION CIRCUIT

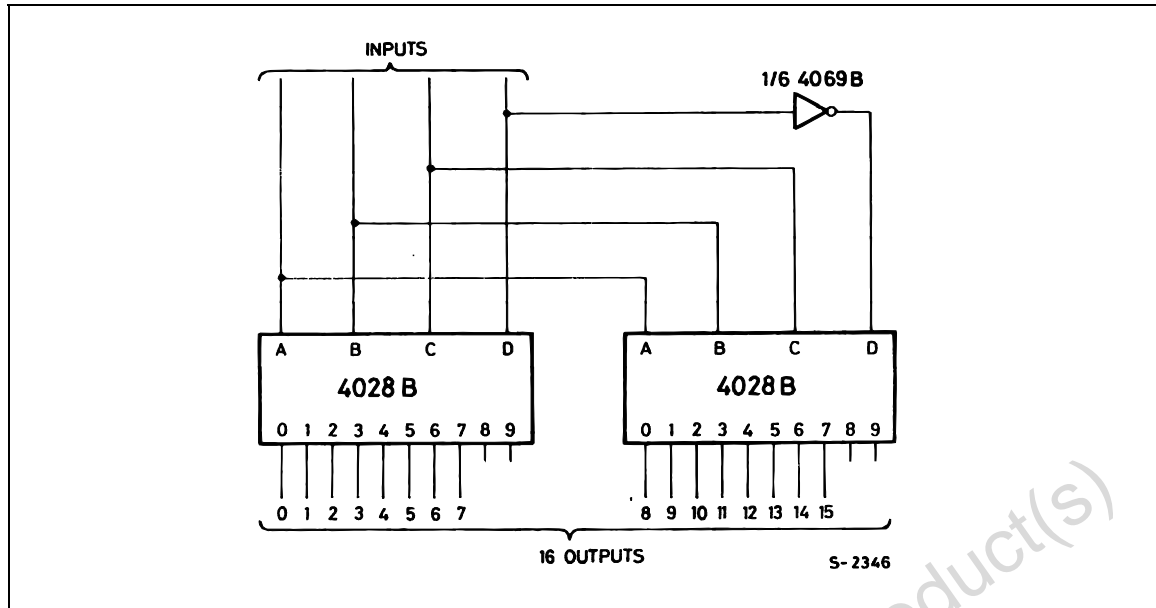

FIGURE 2 : CODE CONVERSION CHART

INPUTS				INPUT CODES						OUTPUT NUMBER															
				HEXA DECIMAL		DECIMAL																			
D	C	B	A	4 BIT BINARY	4 BIT GRAY	EXCESS 3	EXCESS 3 GRAY	AIKEN	4221	0	1	2	3	4	5	6	7	8	9	10	11	12	13	14	15
L	L	L	L	0	0			0	0	H	L	L	L	L	L	L	L	L	L	L	L	L	L	L	L
L	L	L	H	1	1			1	1	L	H	L	L	L	L	L	L	L	L	L	L	L	L	L	L
L	L	H	L	2	3		0	2	2	L	L	H	L	L	L	L	L	L	L	L	L	L	L	L	L
L	L	H	H	3	2	0	3	3		L	L	L	H	L	L	L	L	L	L	L	L	L	L	L	L
L	H	L	L	4	7	1	4	4		L	L	L	L	H	L	L	L	L	L	L	L	L	L	L	L
L	H	L	H	5	6	2			3	L	L	L	L	L	H	L	L	L	L	L	L	L	L	L	L
L	H	H	L	6	4	3	1		4	L	L	L	L	L	L	H	L	L	L	L	L	L	L	L	L
L	H	H	H	7	5	4	2			L	L	L	L	L	L	L	H	L	L	L	L	L	L	L	L
H	L	L	L	8	15	5				L	L	L	L	L	L	L	L	H	L	L	L	L	L	L	L
H	L	L	H	9	14	6			5	L	L	L	L	L	L	L	L	L	H	L	L	L	L	L	L
H	L	H	L	10	12	7	9		6	L	L	L	L	L	L	L	L	L	L	H	L	L	L	L	L
H	L	H	H	11	13	8		5		L	L	L	L	L	L	L	L	L	L	H	L	L	L	L	L
H	H	L	L	12	8	9	5	6		L	L	L	L	L	L	L	L	L	L	L	H	L	L	L	L
H	H	L	H	13	9		6	7	7	L	L	L	L	L	L	L	L	L	L	L	L	H	L	L	L
H	H	H	L	14	11		8	8	8	L	L	L	L	L	L	L	L	L	L	L	L	L	H	L	L
H	H	H	H	15	10		7	9	9	L	L	L	L	L	L	L	L	L	L	L	L	L	L	L	H



FIGURE 3 : 6 BIT BINARY TO 1 OF 64 ADDRESS DECODER

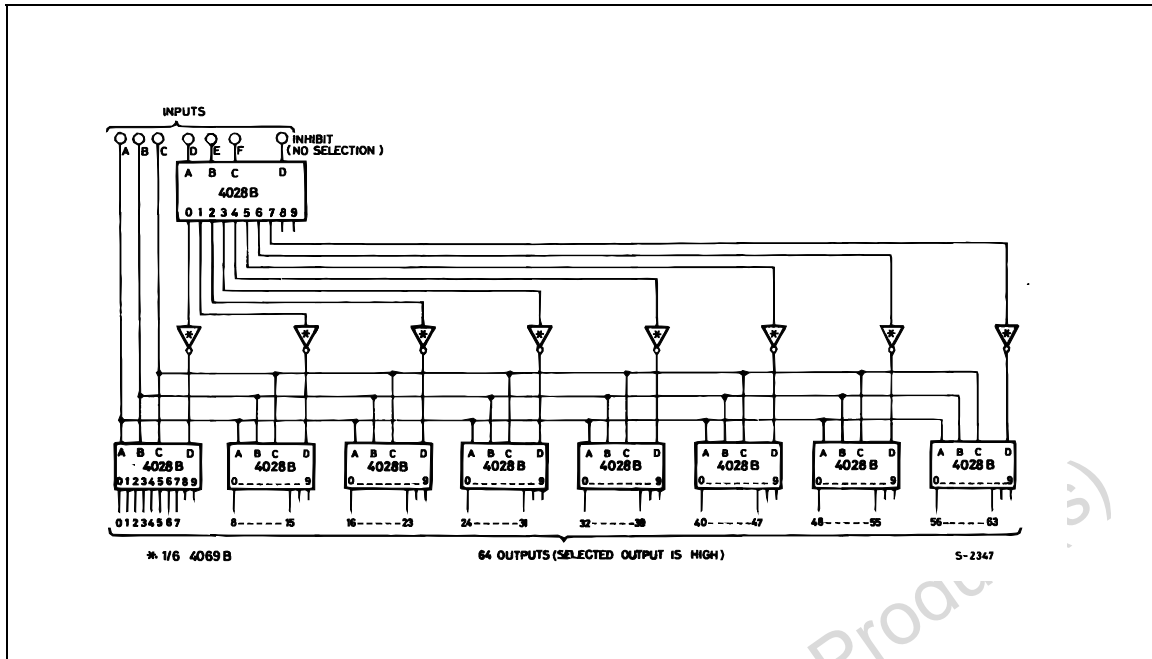
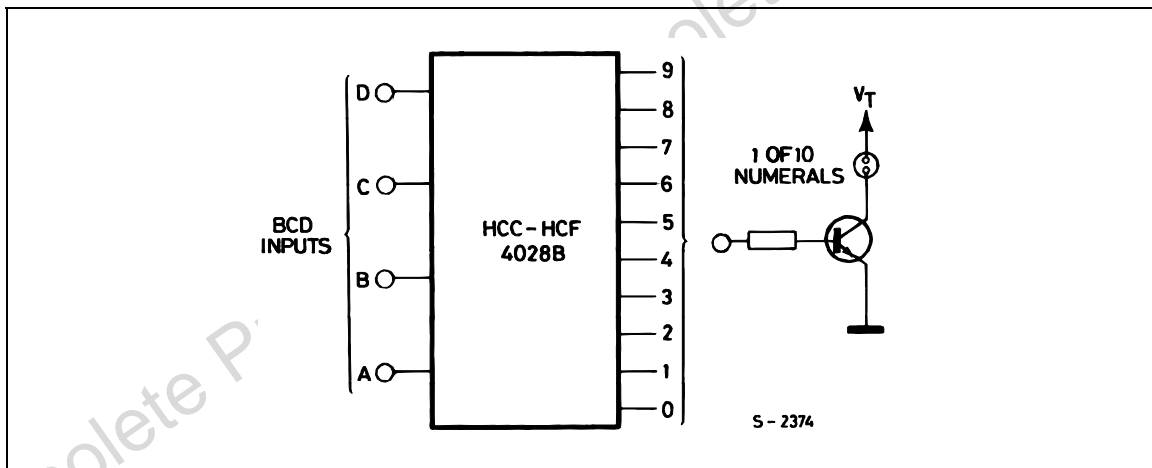
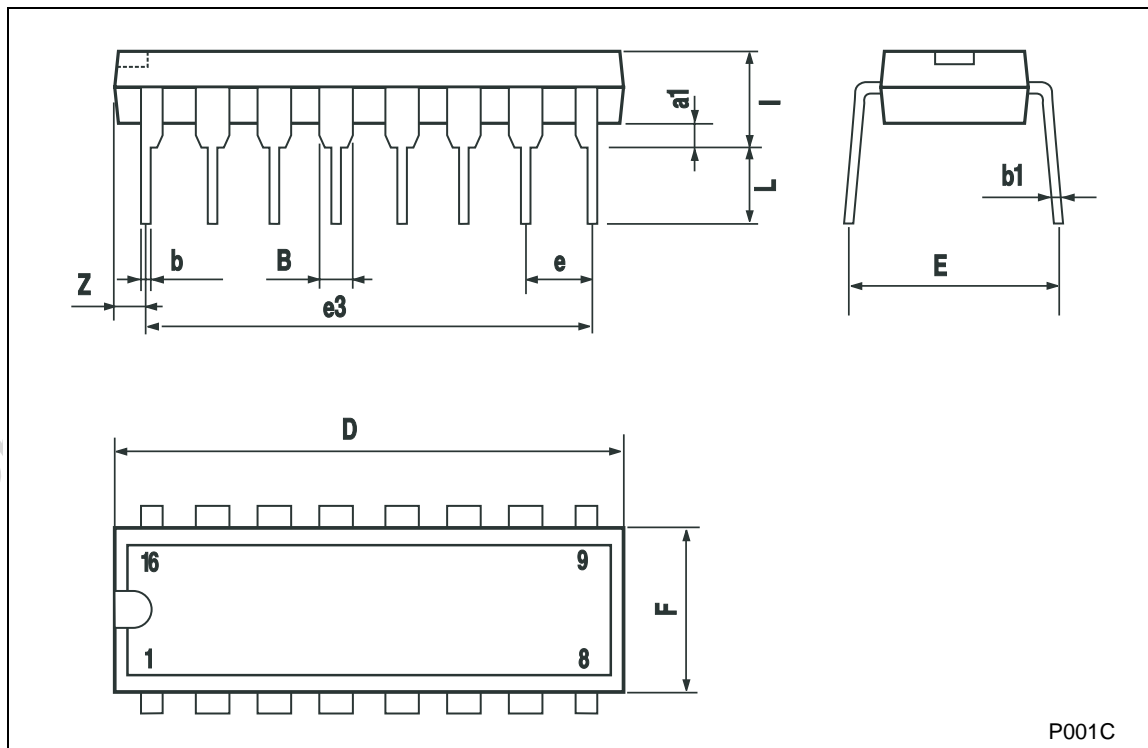

FIGURE 4 : NEON READOUT (NIXIE TUBE) DISPLAY APPLICATION



**Plastic DIP-16 (0.25) MECHANICAL DATA**

DIM.	mm.			inch		
	MIN.	TYP	MAX.	MIN.	TYP.	MAX.
a1	0.51			0.020		
B	0.77		1.65	0.030		0.065
b		0.5			0.020	
b1		0.25			0.010	
D			20			0.787
E		8.5			0.335	
e		2.54			0.100	
e3		17.78			0.700	
F			7.1			0.280
l			5.1			0.201
L		3.3			0.130	
Z			1.27			0.050



P001C



## SO-16 MECHANICAL DATA

DIM.	mm.			inch		
	MIN.	TYP	MAX.	MIN.	TYP.	MAX.
A			1.75			0.068
a1	0.1		0.2	0.003		0.007
a2			1.65			0.064
b	0.35		0.46	0.013		0.018
b1	0.19		0.25	0.007		0.010
C		0.5			0.019	
c1	45° (typ.)					
D	9.8		10	0.385		0.393
E	5.8		6.2	0.228		0.244
e		1.27			0.050	
e3		8.89			0.350	
F	3.8		4.0	0.149		0.157
G	4.6		5.3	0.181		0.208
L	0.5		1.27	0.019		0.050
M			0.62			0.024
S	8° (max.)					

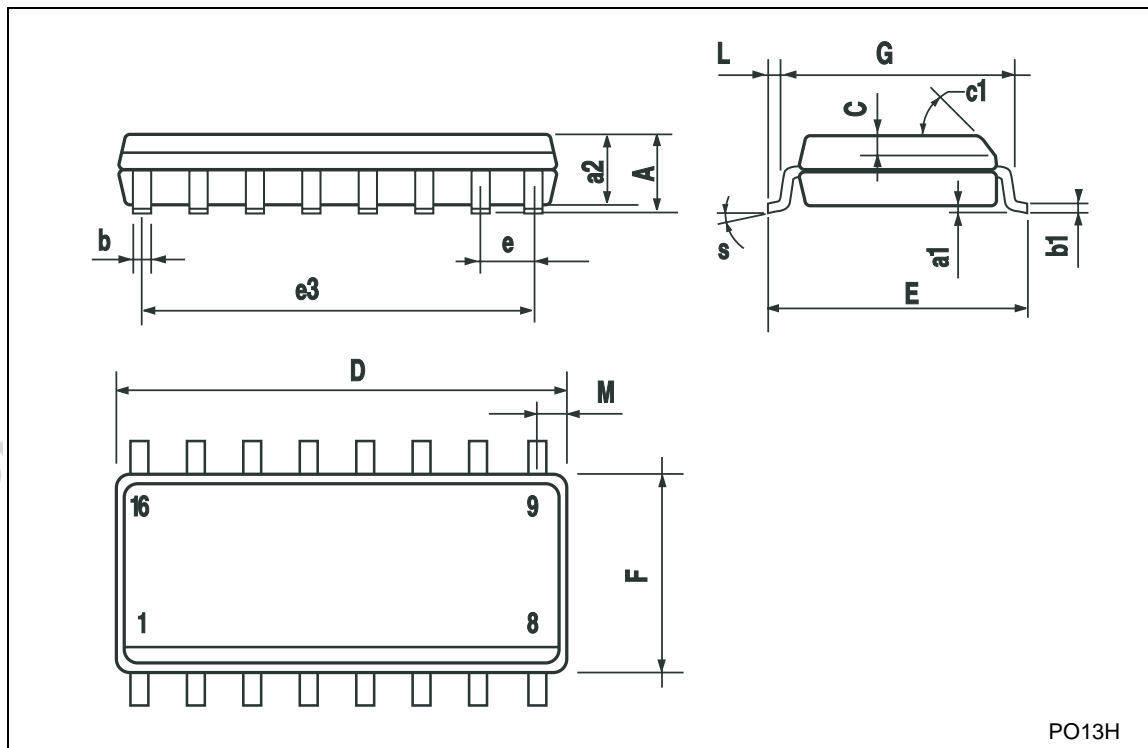

Information furnished is believed to be accurate and reliable. However, STMicroelectronics assumes no responsibility for the consequences of use of such information nor for any infringement of patents or other rights of third parties which may result from its use. No license is granted by implication or otherwise under any patent or patent rights of STMicroelectronics. Specifications mentioned in this publication are subject to change without notice. This publication supersedes and replaces all information previously supplied. STMicroelectronics products are not authorized for use as critical components in life support devices or systems without express written approval of STMicroelectronics.

© The ST logo is a registered trademark of STMicroelectronics

© 2002 STMicroelectronics - Printed in Italy - All Rights Reserved  
STMicroelectronics GROUP OF COMPANIES

Australia - Brazil - Canada - China - Finland - France - Germany - Hong Kong - India - Israel - Italy - Japan - Malaysia - Malta - Morocco  
Singapore - Spain - Sweden - Switzerland - United Kingdom - United States.

© <http://www.st.com>