

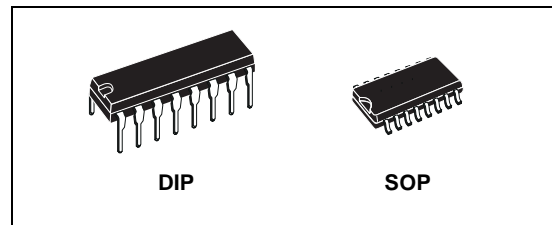

## HCF4021B

### ASYNCHRONOUS PARALLEL IN OR SYNCHRONOUS SERIAL IN/SERIAL OUT 8 - STAGE STATIC SHIFT REGISTER

- MEDIUM SPEED OPERATION : 12 MHz (Typ.) CLOCK RATE AT  $V_{DD} - V_{SS} = 10V$
- FULLY STATIC OPERATION
- 8 MASTER-SLAVE FLIP-FLOPS PLUS OUTPUT BUFFERING AND CONTROL GATING
- QUIESCENT CURRENT SPECIFIED UP TO 20V
- 5V, 10V AND 15V PARAMETRIC RATINGS
- INPUT LEAKAGE CURRENT  
 $I_l = 100nA$  (MAX) AT  $V_{DD} = 18V$   $T_A = 25^\circ C$
- 100% TESTED FOR QUIESCENT CURRENT
- MEETS ALL REQUIREMENTS OF JEDEC JESD13B " STANDARD SPECIFICATIONS FOR DESCRIPTION OF B SERIES CMOS DEVICES"



#### ORDER CODES

PACKAGE	TUBE	T & R
DIP	HCF4021BEY	
SOP	HCF4021BM1	HCF4021M013TR

#### DESCRIPTION

The HCF4021B is a monolithic integrated circuit fabricated in Metal Oxide Semiconductor technology available in DIP and SOP packages. This device is an 8-stage parallel or serial input/serial output register having common CLOCK and PARALLEL/SERIAL CONTROL inputs, a single SERIAL data input, and individual parallel "JAM" inputs to each register stage. Each register stage is a D-type, master-slave flip-flop in addition to an output from stage 8, "Q" outputs are also available from stages 6 and 7. Serial entry is synchronous with the clock but parallel entry is asynchronous.

In this device, entry is controlled by the PARALLEL/SERIAL CONTROL input. When the PARALLEL/SERIAL CONTROL input is low, data is serially shifted into the 8-stage register synchronously with the positive transition of the clock line. When the PARALLEL/SERIAL CONTROL input is high, data is jammed into the 8-stage register via the parallel input lines and synchronous with the positive transition of the clock line, the CLOCK input of the internal stage is "forced" when asynchronous parallel entry is made. Register expansion using multiple package is permitted.

#### PIN CONNECTION

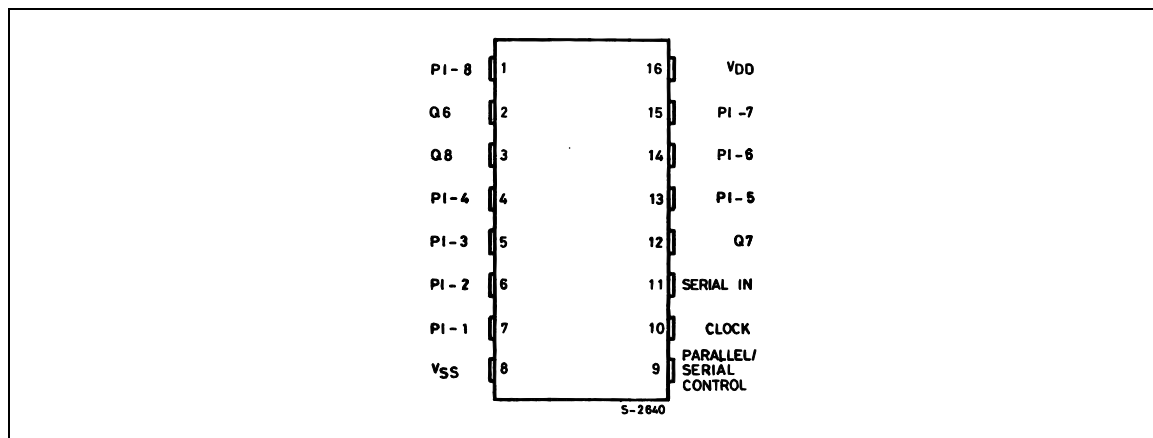

# HCF4021B

## INPUT EQUIVALENT CIRCUIT

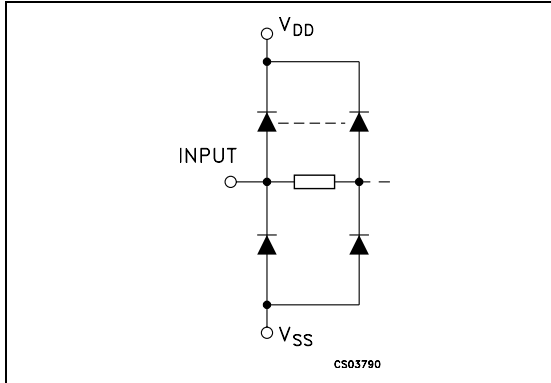

## PIN DESCRIPTION

PIN No	SYMBOL	NAME AND FUNCTION
7, 6, 5, 4, 13, 14, 15, 1	PI1 to PI8	Parallel Input
11	SERIAL IN	Serial Input
9	PARALLEL/SERIAL CONTROL	Parallel/Serial Input Control
10	CLOCK	Clock Input
2, 3, 12	Q6, Q7, Q8	Buffered Outputs
8	$V_{SS}$	Negative Supply Voltage
16	$V_{DD}$	Positive Supply Voltage

## TRUTH TABLE

CLOCK	SERIAL INPUT	PARALLEL/SERIAL CONTROL	PI - 1	PI - n	$Q_1$ (INTERNAL)	$Q_n$
X	X	1	0	0	0	0
X	X	1	0	1	0	1
X	X	1	1	0	1	0
X	X	1	1	1	1	1
	0	0	X	X	0	$Q_n - 1$
	1	0	X	X	1	$Q_n - 1$
	X	X	X	X	$Q_1$	$Q_n$

X : Don't Care

## LOGIC DIAGRAM

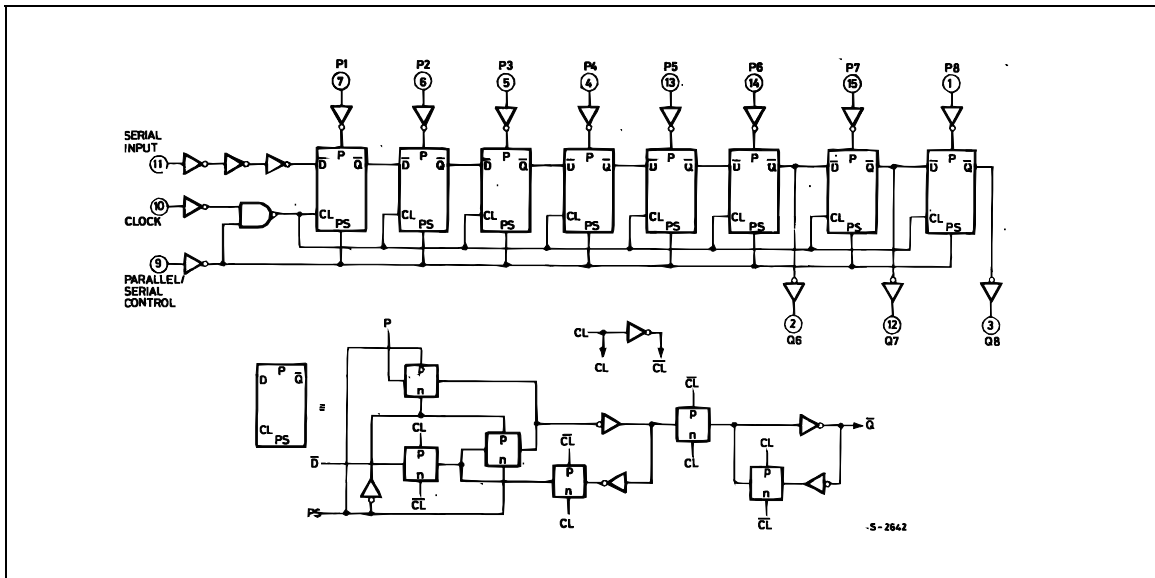

**ABSOLUTE MAXIMUM RATINGS**

Symbol	Parameter	Value	Unit
$V_{DD}$	Supply Voltage	-0.5 to +22	V
$V_I$	DC Input Voltage	-0.5 to $V_{DD} + 0.5$	V
$I_I$	DC Input Current	$\pm 10$	mA
$P_D$	Power Dissipation per Package	200	mW
	Power Dissipation per Output Transistor	100	mW
$T_{op}$	Operating Temperature	-55 to +125	°C
$T_{stg}$	Storage Temperature	-65 to +150	°C

Absolute Maximum Ratings are those values beyond which damage to the device may occur. Functional operation under these conditions is not implied.

All voltage values are referred to  $V_{SS}$  pin voltage.

**RECOMMENDED OPERATING CONDITIONS**

Symbol	Parameter	Value	Unit
$V_{DD}$	Supply Voltage	3 to 20	V
$V_I$	Input Voltage	0 to $V_{DD}$	V
$T_{op}$	Operating Temperature	-55 to 125	°C

DC SPECIFICATIONS

Symbol	Parameter	Test Condition				Value						Unit	
		V <sub>I</sub> (V)	V <sub>O</sub> (V)	I <sub>oI</sub> ( $\mu$ A)	V <sub>DD</sub> (V)	T <sub>A</sub> = 25°C			-40 to 85°C		-55 to 125°C		
						Min.	Typ.	Max.	Min.	Max.	Min.		Max.
I <sub>L</sub>	Quiescent Current	0/5			5		0.04	5		150		150	$\mu$ A
		0/10			10		0.04	10		300		300	
		0/15			15		0.04	20		600		600	
		0/20			20		0.08	100		3000		3000	
V <sub>OH</sub>	High Level Output Voltage	0/5		<1	5	4.95			4.95		4.95		V
		0/10		<1	10	9.95			9.95		9.95		
		0/15		<1	15	14.95			14.95		14.95		
V <sub>OL</sub>	Low Level Output Voltage	5/0		<1	5		0.05			0.05		0.05	V
		10/0		<1	10		0.05			0.05		0.05	
		15/0		<1	15		0.05			0.05		0.05	
V <sub>IH</sub>	High Level Input Voltage		0.5/4.5	<1	5	3.5			3.5		3.5		V
			1/9	<1	10	7			7		7		
			1.5/13.5	<1	15	11			11		11		
V <sub>IL</sub>	Low Level Input Voltage		4.5/0.5	<1	5			1.5		1.5		1.5	V
			9/1	<1	10			3		3		3	
			13.5/1.5	<1	15			4		4		4	
I <sub>OH</sub>	Output Drive Current	0/5	2.5	<1	5	-1.36	-3.2		-1.1		-1.1		mA
		0/5	4.6	<1	5	-0.44	-1		-0.36		-0.36		
		0/10	9.5	<1	10	-1.1	-2.6		-0.9		-0.9		
		0/15	13.5	<1	15	-3.0	-6.8		-2.4		-2.4		
I <sub>OL</sub>	Output Sink Current	0/5	0.4	<1	5	0.44	1		0.36		0.36		mA
		0/10	0.5	<1	10	1.1	2.6		0.9		0.9		
		0/15	1.5	<1	15	3.0	6.8		2.4		2.4		
I <sub>I</sub>	Input Leakage Current	0/18	Any Input		18		$\pm 10^{-5}$	$\pm 0.1$		$\pm 1$		$\pm 1$	$\mu$ A
C <sub>I</sub>	Input Capacitance		Any Input				5	7.5					pF

The Noise Margin for both "1" and "0" level is: 1V min. with V<sub>DD</sub>=5V, 2V min. with V<sub>DD</sub>=10V, 2.5V min. with V<sub>DD</sub>=15V

**DYNAMIC ELECTRICAL CHARACTERISTICS** ( $T_{amb} = 25^{\circ}\text{C}$ ,  $C_L = 50\text{pF}$ ,  $R_L = 200\text{K}\Omega$ ,  $t_r = t_f = 20\text{ ns}$ )

Symbol	Parameter	Test Condition		Value (*)			Unit
		$V_{DD}$ (V)		Min.	Typ.	Max.	
<b>CLOCKED OPERATION</b>							
$t_{PLH}$ $t_{PHL}$	Propagation Delay Time	5			160	320	ns
		10			80	160	
		15			60	120	
$t_{THL}$ $t_{TLH}$	Transition Time	5			100	200	ns
		10			50	100	
		15			40	80	
$f_{CL}$ (1)	Maximum Clock Input Frequency	5		3	6		MHz
		10		6	12		
		15		8.5	17		
$t_W$	Clock Pulse Width	5		180	90		ns
		10		80	40		
		15		50	25		
$t_r$ , $t_f$	Clock Input Rise or Fall Time	5				15	$\mu\text{s}$
		10				15	
		15				15	
$t_{setup}$	Setup Time, serial Input (ref to CL)	5		120	60		ns
		10		80	40		
		15		60	30		
$t_{setup}$	Setup Time, Parallel Inputs (ref to P/S)	5		50	25		ns
		10		30	15		
		15		20	10		
$t_{hold}$	Hold Time, serial in, parallel in, parallel /serial control	5		0			ns
		10		0			
		15		0			
$t_{WH}$	P/S Pulse Width	5		160	80		ns
		10		80	40		
		15		50	25		
$t_{rem}$	P/S Removal Time (ref to CL)	5		280	140		ns
		10		140	70		
		15		100	50		

(\*) Typical temperature coefficient for all  $V_{DD}$  value is 0.3 %/°C.

(1) If more than one unit is cascaded  $t_{CL}$  should be made less than or equal to the sum of the transition time and the fixed propagation delay of the output of the driving stage of the estimated capacitive load.

TEST CIRCUIT

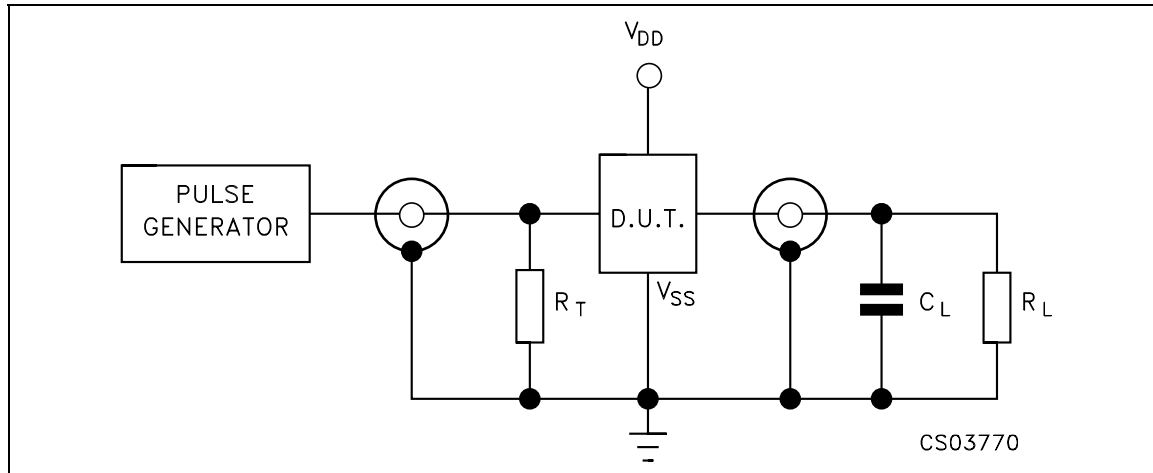

$C_L = 50\text{pF}$  or equivalent (includes jig and probe capacitance)  
 $R_L = 200\text{K}\Omega$   
 $R_T = Z_{OUT}$  of pulse generator (typically  $50\Omega$ )

WAVEFORM 1 : PROPAGATION DELAY TIMES, CLOCK PULSE WIDTH ( $f=1\text{MHz}$ ; 50% duty cycle)

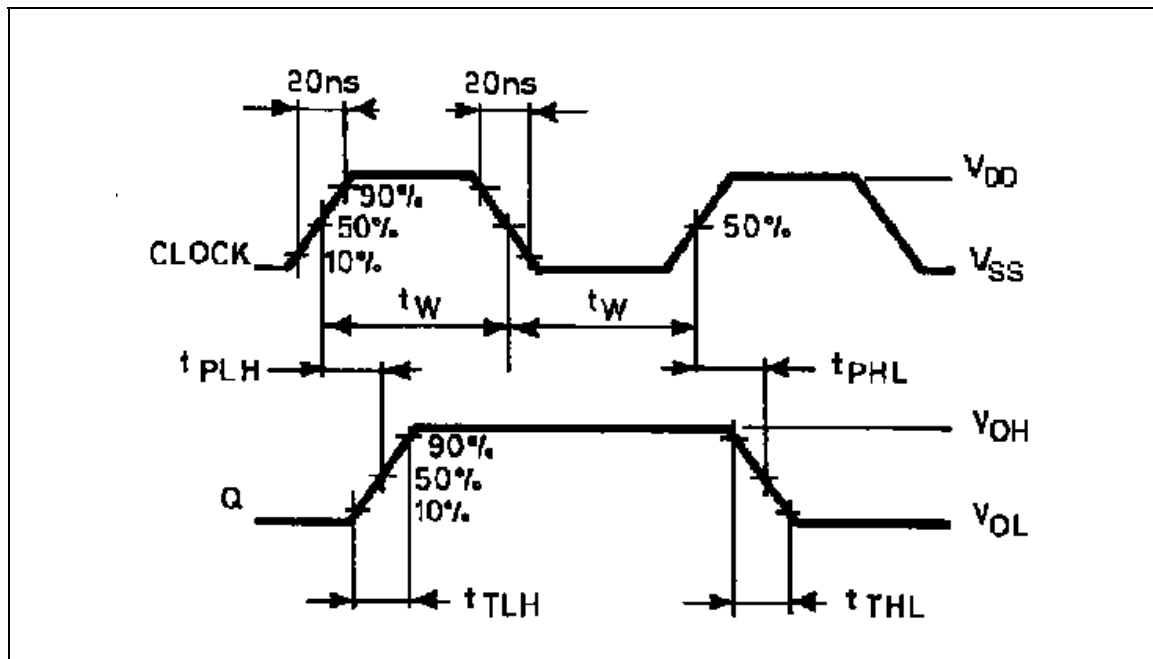

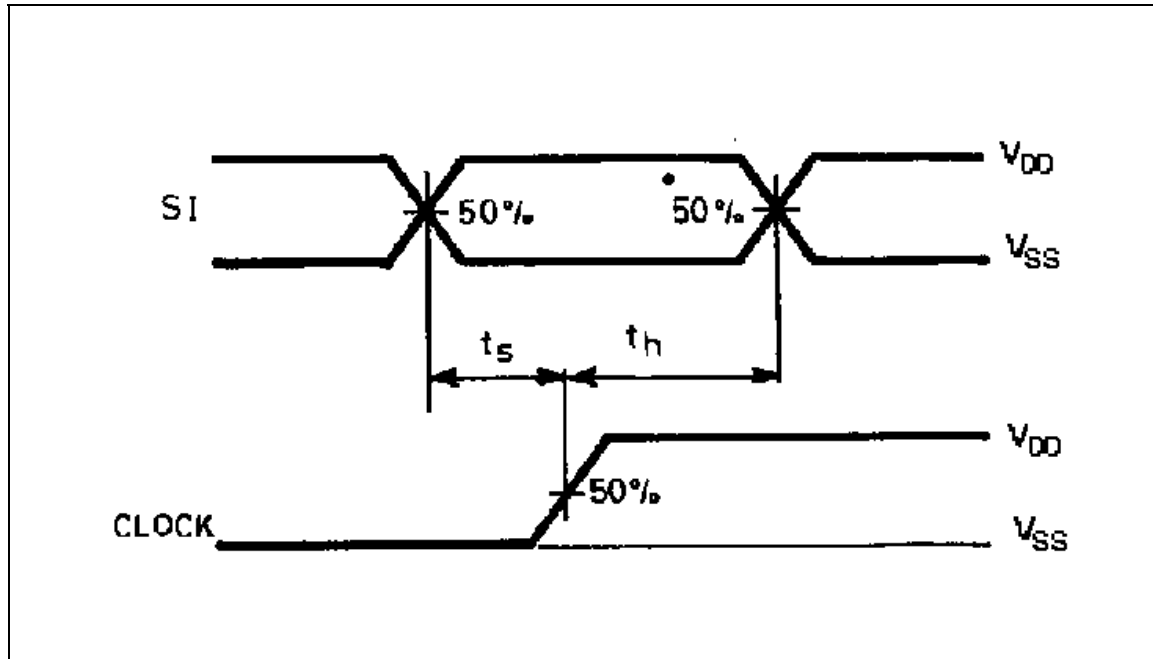
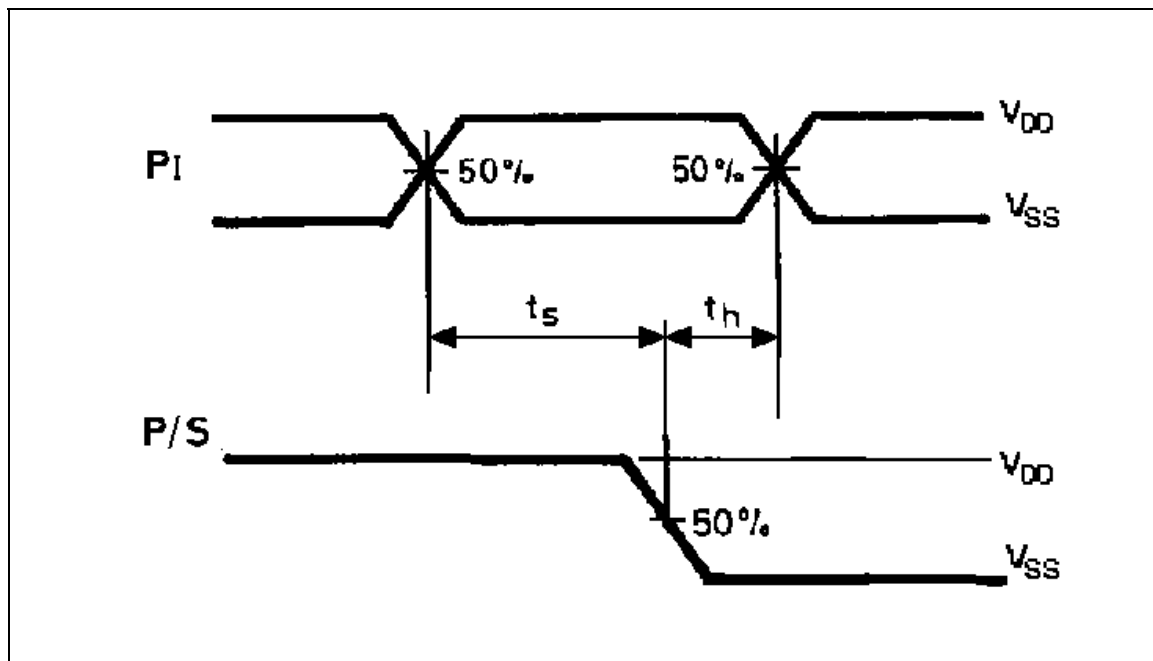
**WAVEFORM 2 : SETUP AND HOLD TIMES (SI TO CLOCK)** ( $f=1\text{MHz}$ ; 50% duty cycle)**WAVEFORM 3 : SETUP AND HOLD TIME (PI TO P/S)** ( $f=1\text{MHz}$ ; 50% duty cycle)

WAVEFORM 4 : PULSE WIDTH AND REMOVAL TIME (P/S TO CLOCK) (f=1MHz; 50% duty cycle)

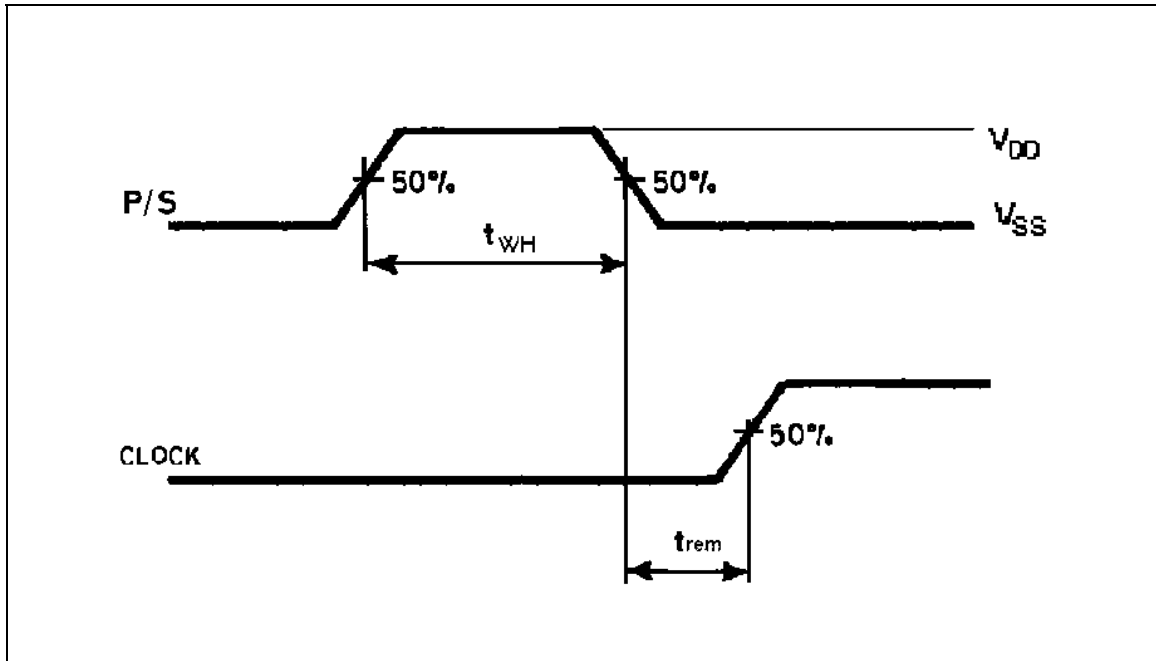



### Plastic DIP-16 (0.25) MECHANICAL DATA

DIM.	mm.			inch		
	MIN.	TYP	MAX.	MIN.	TYP.	MAX.
a1	0.51			0.020		
B	0.77		1.65	0.030		0.065
b		0.5			0.020	
b1		0.25			0.010	
D			20			0.787
E		8.5			0.335	
e		2.54			0.100	
e3		17.78			0.700	
F			7.1			0.280
I			5.1			0.201
L		3.3			0.130	
Z			1.27			0.050

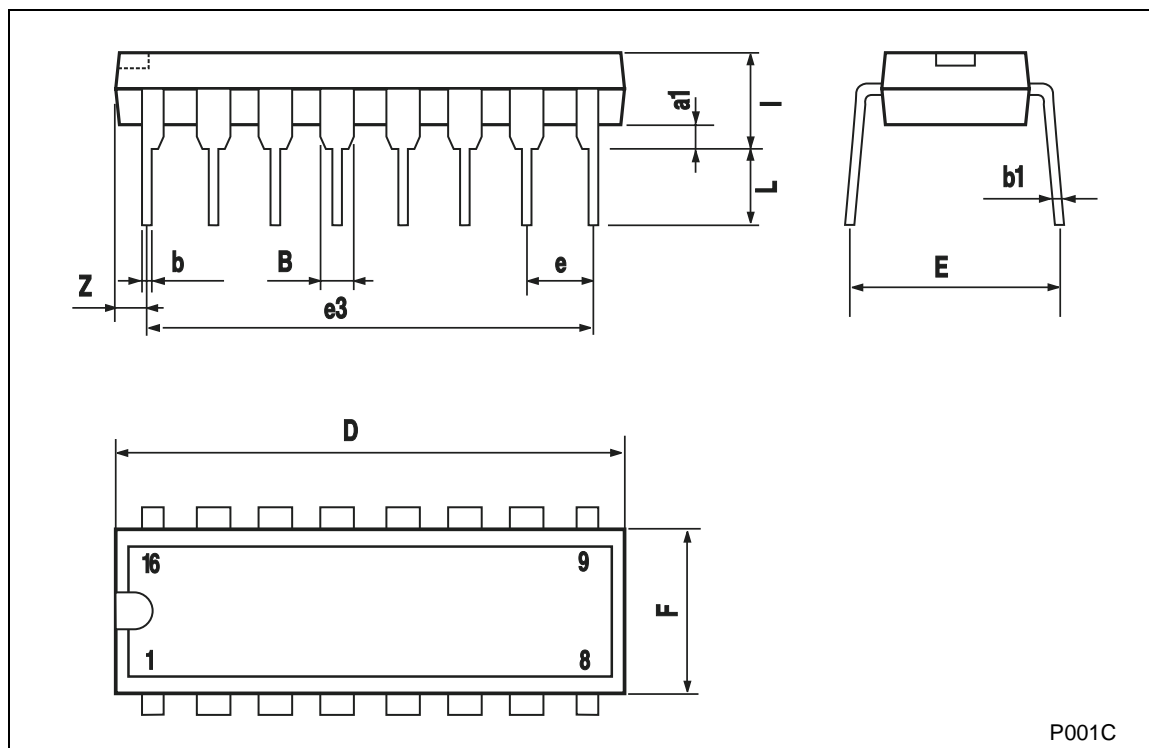

## SO-16 MECHANICAL DATA

DIM.	mm.			inch		
	MIN.	TYP	MAX.	MIN.	TYP.	MAX.
A			1.75			0.068
a1	0.1		0.2	0.003		0.007
a2			1.65			0.064
b	0.35		0.46	0.013		0.018
b1	0.19		0.25	0.007		0.010
C		0.5			0.019	
c1	45° (typ.)					
D	9.8		10	0.385		0.393
E	5.8		6.2	0.228		0.244
e		1.27			0.050	
e3		8.89			0.350	
F	3.8		4.0	0.149		0.157
G	4.6		5.3	0.181		0.208
L	0.5		1.27	0.019		0.050
M			0.62			0.024
S	8° (max.)					

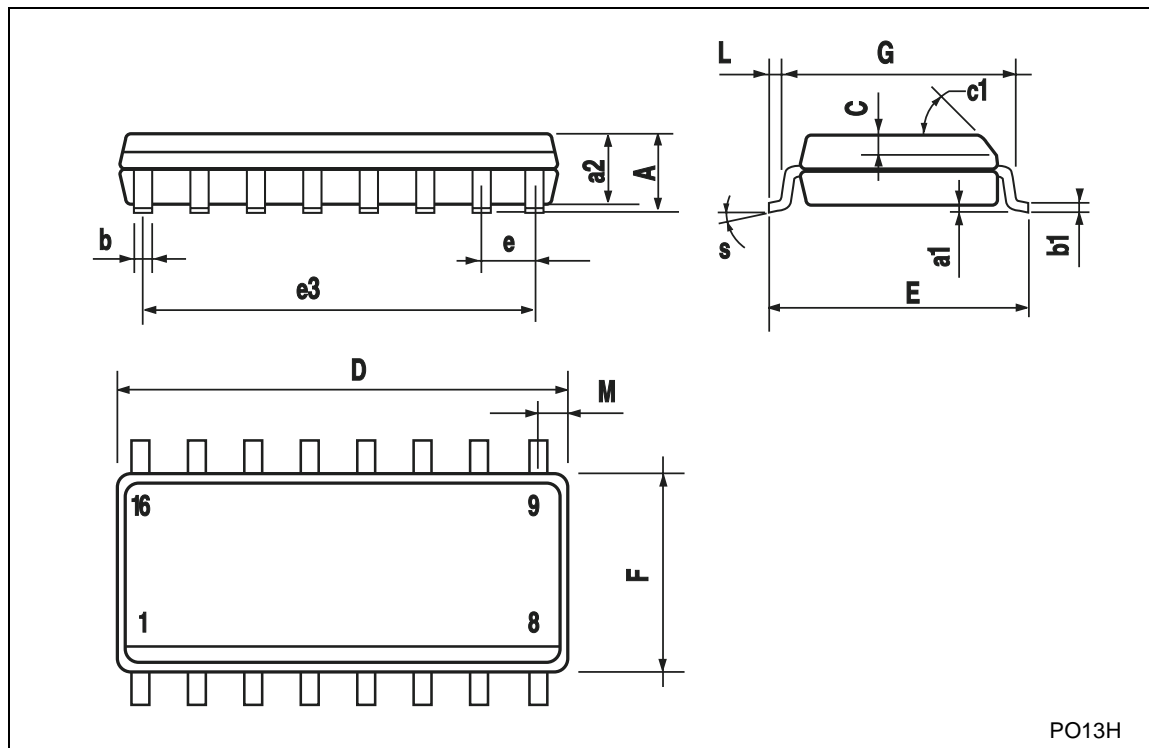

PO13H

Information furnished is believed to be accurate and reliable. However, STMicroelectronics assumes no responsibility for the consequences of use of such information nor for any infringement of patents or other rights of third parties which may result from its use. No license is granted by implication or otherwise under any patent or patent rights of STMicroelectronics. Specifications mentioned in this publication are subject to change without notice. This publication supersedes and replaces all information previously supplied. STMicroelectronics products are not authorized for use as critical components in life support devices or systems without express written approval of STMicroelectronics.

© The ST logo is a registered trademark of STMicroelectronics

© 2001 STMicroelectronics - Printed in Italy - All Rights Reserved  
STMicroelectronics GROUP OF COMPANIES

Australia - Brazil - China - Finland - France - Germany - Hong Kong - India - Italy - Japan - Malaysia - Malta - Morocco  
Singapore - Spain - Sweden - Switzerland - United Kingdom

© <http://www.st.com>

