

16-Bit Transparent D-Type Latch with 3-STATE Outputs

Product Features

- PI74ALVTC family is designed for low voltage operation, $V_{DD} = 1.8V$ to $3.6V$
- Supports Live Insertion
- 3.6V I/O Tolerant Inputs and Outputs
- Bus Hold
- High Drive, $-32/64mA @ 3.3V$
- Uses patented noise reduction circuitry
- Power-off high impedance inputs and outputs
- Industrial operation at $-40^{\circ}C$ to $+85^{\circ}C$
- Packages available:
 - 48-pin 240 mil wide plastic TSSOP (A)
 - 48-pin 173 mil wide plastic TVSOP (K)
 - 48-pin 300 mil wide plastic SSOP (V)

Product Description

Pericom Semiconductor’s PI74ALVTC series of logic circuits are produced in the Company’s advanced 0.35 micron CMOS technology, achieving industry leading speed.

The PI74ALVTC16373 is particularly suitable for implementing buffer registers, I/O ports, bidirectional bus drivers, and working registers. This device can be used as two 8-bit latches or one 16-bit latch. When the Latch Enable (LE) input is HIGH, the Q outputs follow the (D) inputs. When LE is taken LOW, the Q outputs are latched at the levels set up at the D inputs.

A buffered Output Enable (\overline{OE}) input can be used to place the eight outputs in either a normal logic state (high or low logic levels) or a high-impedance state in which the outputs neither load nor drive the bus lines significantly. The high-impedance state and the increased drive provide the capability to drive bus lines without an interface or pullup components. \overline{OE} does not affect internal operations of the latch. Old data can be retained or new data can be entered while the outputs are in the high-impedance state.

To ensure the high-impedance state during power up or power down, \overline{OE} should be tied to V_{DD} through a pullup resistor; the minimum value of the resistor is determined by the current-sinking capability of the driver.

The family offers both I/O Tolerant, which allows it to operate in mixed 1.8/3.6V systems, and “Bus Hold,” which retains the data input’s last state whenever the data input goes to high-impedance, preventing “floating” inputs and eliminating the need for pullup/down resistors.

Logic Block Diagram

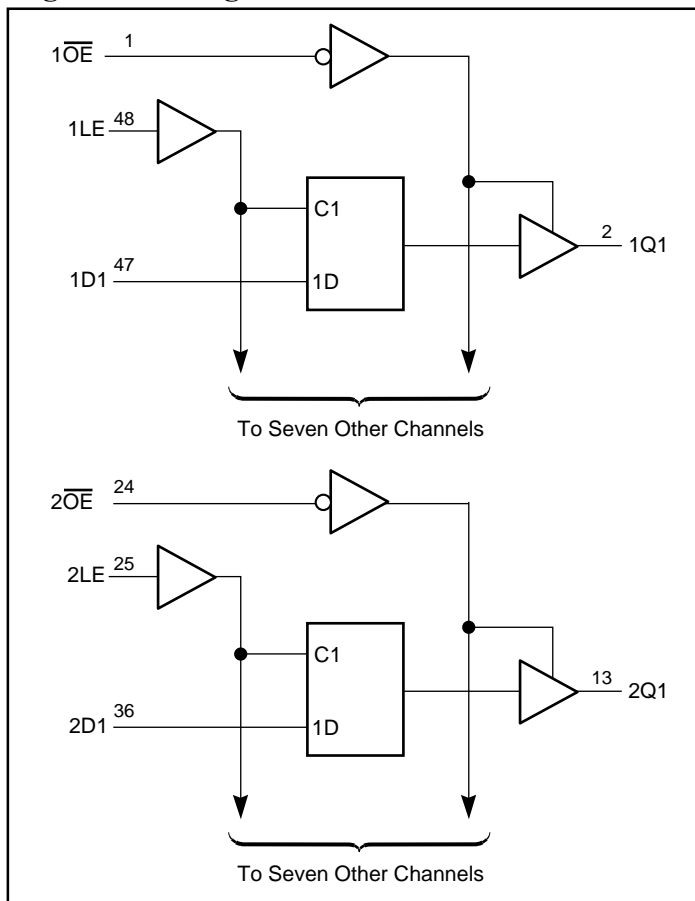

Product Pin Description

Pin Name	Description
\overline{OE}	Output Enable Input (Active LOW)
LE	Latch Enable (Active HIGH)
Dx	Data Inputs
Qx	3-State Outputs
GND	Ground
Vcc	Power

Truth Table⁽¹⁾

Inputs ⁽¹⁾			Outputs ⁽¹⁾
\overline{OE}	LE	D	Q
L	H	H	H
L	H	L	L
L	L	X	Q _o
H	X	X	Z

Note:

- H = High Signal Level
 L = Low Signal Level
 X = Don't Care or Irrelevant
 Z = High Impedance

Product Pin Configuration

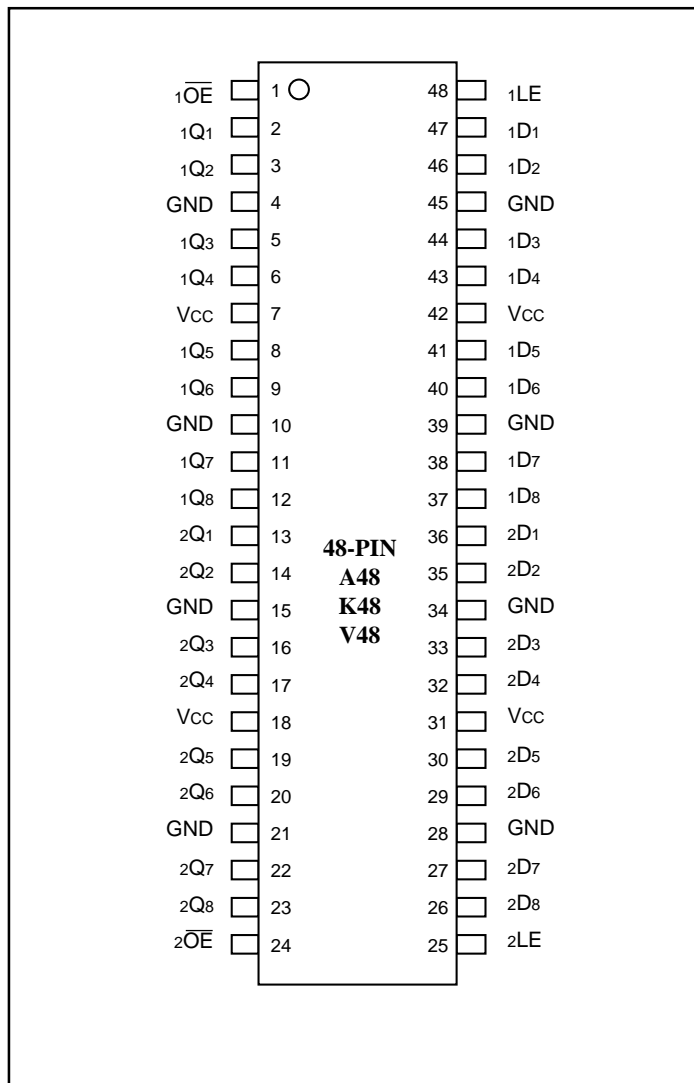

Maximum Ratings

(Above which the useful life may be impaired. For user guidelines, not tested.)

Supply Voltage Range, V_{DD}	-0.5V to 4.6V
Input Voltage Range, V_I	-0.5V to 4.6V
Output Voltage Range, V_O (3-States)	-0.5V to 4.6V
Output Voltage Range, $V_O^{(1)}$ (Active)	-0.5V to $V_{DD}+0.5V$
DC Input Diode Current (I_{IK}) $V_I < 0V$	-50mA
DC Output Diode Current (I_{OK})	
$V_O < 0V$	-50mA
$V_O > V_{DD}$	$\pm 50mA$
DC Output Source/Sink Current (I_{OH}/I_{OL})	-64/128mA
DC V_{DD} or GND Current per Supply Pin (I_{CC} or GND)	$\pm 100mA$
Storage Temperature Range, T_{stg}	-65°C to 150°C

Note:

Stresses greater than those listed under MAXIMUM RATINGS may cause permanent damage to the device. This is a stress rating only and functional operation of the device at these or any other conditions above those indicated in the operational sections of this specification is not implied. Exposure to absolute maximum rating conditions for extended periods may affect reliability.

Recommended Operating Conditions²

			Min.	Max.	Units
V_{DD}	Supply voltage	Operating	1.8	3.6	V
		Data Retention Only	1.2	3.6	
V_{IH}	High-level input voltage	$V_{DD} = 2.7V$ to 3.6V	2.0		
V_{IL}	Low-level input voltage	$V_{DD} = 2.7V$ to 3.6V		0.8	
V_I	Input voltage		-0.3	3.6	
V_O	Output voltage	Active State	0	V_{DD}	
		Off State	0	3.6	
	Output current in I_{OH}/I_{OL}	$V_{DD} = 3.0V$ to 3.6V $V_{DD} = 3.0V$ to 3.6V $V_{DD} = 2.3V$ to 2.7V $V_{DD} = 1.8V$		-32/64 ± 24 ± 18 ± 6	mA
$\Delta t/\Delta v$	Input transition rise or fall rate ⁽³⁾		0	10	ns/V
T_A	Operating free-air temperature		-40	85	C

Notes

1. Absolute maximum of I_O must be observed.
2. Unused control inputs must be held HIGH or LOW to prevent them from floating.
- 3 As measured between 0.8V and 2.0V, $V_{DD} = 3.0V$.

Electrical Characteristics over Recommended Operating Free-Air Temperature Range

(unless otherwise noted)

DC Characteristics (2.7V V_{DD} ≤ 3.6V)

	Parameter	Conditions	V_{DD}	Min.	Typ.	Max.	Units
V_{IH}	HIGH Level Input Voltage		2.7 - 3.6	2.0			V
V_{IL}	LOW Level Input Voltage					0.8	
V_{OH}	HIGH Level Output Voltage	$I_{OH} = -100\mu A$		$V_{DD} - 0.2$			
		$I_{OH} = -12mA$	2.7	2.2			
		$I_{OH} = -18mA$	3.0	2.4			
		$I_{OH} = -24mA$		2.2			
		$I_{OH} = -32mA$		2.0			
V_{OL}	LOW Level Output Voltage	$I_{OL} = 100\mu A$	2.7 - 3.6			0.2	
		$I_{OL} = 12mA$	2.7			0.4	
		$I_{OL} = 18mA$	3.0			0.4	
		$I_{OL} = 24mA$				0.45	
		$I_{OL} = 32mA$				0.5	
		$I_{OL} = 64mA$				0.55	
I_I	Input Leakage Current	$V_I = V_{DD}$, or GND	3.6			±5.0	μA
I_{OZ}	3-STATE Output Leakage	$V_O = 3.6V$	2.7			±10	
I_{OFF}	Power-OFF Leakage Current	V_I or $V_O \leq 3.6V$	0			10	
I_{ODL}	Output Current Low	$V_{IN} = V_{IH}$ or V_{IL} , $V_O = 1.5V^{(1)}$	3.6	150		334	mA
I_{ODH}	Output Current High	$V_{IN} = V_{IH}$ or V_{IL} , $V_O = 1.5V^{(1)}$		-58		-114	
I_{HOLD}	Bus Hold Current A or B Outputs	$V_I = 0.8V$	3.0	75			μA
		$V_I = 2.0V$		-75			
		$V_I = 0$ to 3.6V	3.6			±500	
I_{DD}	Quiescent Supply Current	$V_I = V_{DD}$ or GND	2.7 - 3.6			50	
		$V_{DD} \leq (V_I, V_O) \leq 3.6V$				±50	
ΔI_{DD}	Increase in I_{DD} per input	$V_{IH} = V_{DD} - 0.6V$, Other inputs at V_{DD} or Gnd					

Notes

1. Duration of test must not exceed 1 second with only 1 output tested at a time.

Electrical Characteristics over Recommended Operating Free-Air Temperature Range

(unless otherwise noted) (continued from previous page)

DC Characteristics ($2.3V \leq V_{DD} \leq 2.7V$)

Description	Parameters	Conditions	V_{DD}	Min.	Typ.	Max.	Units
V_{IH}	HIGH Level Input Voltage		2.3 - 2.7	1.6			V
V_{IL}	LOW Level Input Voltage					0.7	
V_{OH}	HIGH Level Output Voltage	$I_{OH} = -100\mu A$	2.3	$V_{DD} - 0.2$			
		$I_{OH} = -12mA$		1.8			
		$I_{OH} = -18mA$		1.7			
V_{OL}	LOW Level Output Voltage		2.3 - 2.7			0.2	
		$I_{OL} = 12mA$	2.3			0.4	
		$I_{OL} = 18mA$				0.5	
		$I_{OL} = 24mA$				0.55	
I_I	Input Leakage Current	$V_I = V_{DD}$ or GND	2.7			± 5.0	μA
I_{OZ}	3-STATE Output Leakage	$V_O = 3.6V$	2.3			± 10	
I_{OFF}	Power-OFF Leakage Current	V_I or $V_O \leq 3.6V$	0			10	
I_{ODL}	Output Current Low	$V_{IN} = V_{IH}$ or V_{IL} , $V_O = 1.5V^{(2)}$	2.7	110		264	mA
I_{ODH}	Output Current High	$V_{IN} = V_{IH}$ or V_{IL} , $V_O = 1.5V^{(2)}$		-30		-60	
$I_{HOLD}^{(1)}$	Bus Hold Current A or B Outputs	$V_I = 0.7V$	2.5		90		μA
		$V_I = 1.7V$			-90		
I_{DD}	Quiescent Supply Current	$V_I = V_{DD}$ or GND	2.3 - 2.7			40	μA
		$V_{DD} \leq (V_I, V_O) \leq 3.6V$				± 40	
ΔI_{DD}	Increase in I_{DD} per input	$V_{IH} = V_{DD} - 0.6V$, Inputs at V_{DD} or Gnd					

Notes:

1. Not Guaranteed
2. Duration of test must not exceed 1 second with only 1 output tested at a time.

Electrical Characteristics over Recommended Operating Free-Air Temperature Range

(unless otherwise noted) (continued from previous page)

DC Characteristics ($1.8V \leq V_{DD} \leq 2.3V$)

Description	Parameters	Conditions	V_{DD}	Min.	Typ.	Max.	Units	
V_{IH}	HIGH Level Input Voltage		1.8 - 2.3	$0.7 \times V_{DD}$			V	
V_{IL}	LOW Level Input Voltage					$0.2 \times V_{DD}$		
V_{OH}	HIGH Level Output Voltage	$I_{OH} = -100\mu A$	1.8	$V_{DD} - 0.2$				
		$I_{OH} = -6mA$		1.4				
V_{OL}	LOW Level Output Voltage	$I_{OL} = 100\mu A$				0.2		
		$I_{OL} = 6mA$				0.3		
I_I	Input Leakage Current	$V_I = V_{DD}$ or GND	2.3			± 5.0	μA	
I_{OZ}	3-State Output Leakage	$V_O = 3.6V$	1.8			± 10		
I_{OFF}	Power-OFF Leakage Current	$V_I = V_O \leq 3.6V$	0			10		
I_{ODL}	Output Current Low	$V_{IN} = V_{IH}$ or V_{IL} , $V_O = 0.9V^{(2)}$	1.8	50		137	mA	
I_{ODH}	Output Current High	$V_{IN} = V_{IH}$ or V_{IL} , $V_O = 0.9V^{(2)}$		-14		-34		
$I_{HOLD}^{(1)}$	Bus Hold Current A or B Outputs	$V_I = 0.4$	1.8		50		μA	
		$V_I = 1.3$			-50			
I_{DD}	Quiescent Supply Current	$V_I = V_{DD}$ or GND						20
		$V_{DD} \leq (V_I, V_O) \leq 3.6V$						± 20
ΔI_{DD}	Increase in I_{DD} per input	$V_I = V_{DD} - 0.6V$, Other inputs at V_{DD} or Gnd				400		

Notes:

1. Not Guaranteed
2. Duration of test must not exceed 1 second with only 1 output tested at a time.

AC Electrical Characteristics

Symbol	Parameter	$T_A = -40^{\circ}\text{C to } +85^{\circ}\text{C}, C_L = 50\text{pF}, R_L = 500\Omega$						Units
		$V_{DD} = 3.3\text{V} \pm 0.3\text{V}$		$V_{DD} = 2.5\text{V} \pm 0.2\text{V}$		$V_{DD} = 1.8\text{V}$		
		Min.	Max.	Min.	Max.	Min.	Max.	
t_{PLH}, t_{PHL}	Prop Delay, D to Q	0.5	2.5	1.0	3.2	1.5	4.0	ns
t_{PLH}, t_{PHL}	Prop Delay, LE to Q	1.0	3.1	1.5	4.2	2.0	4.5	
t_{PZH}, t_{PZL}	Output Enable Time	1.0	3.1	1.5	4.7	2.0	4.5	
t_{PHZ}, t_{PLZ}	Output Disable Time	1.5	3.7	1.5	3.5	2.0	5.0	
t_{OSHL} t_{OSLH}	Output to Output Skew ⁽¹⁾		0.5		0.5		0.5	

Note

- Skew is defined as the absolute value of the difference between the actual propagation delay for any two separate outputs of the same device. The specification applies to any outputs switching in the same direction, either HIGH or LOW (t_{OSHL}) or LOW to HIGH (t_{OSLH}).

AC Setup Requirements

Symbol	Parameter	$T_A = -40^{\circ}\text{C to } +85^{\circ}\text{C}, C_L = 50\text{pF}, R_L = 500\Omega$						Units
		$V_{DD} = 3.3\text{V} \pm 0.3\text{V}$		$V_{DD} = 2.5\text{V} \pm 0.2\text{V}$		$V_{DD} = 1.8\text{V}$		
		Min.	Typ.	Min.	Typ.	Min.	Typ.	
t_{SU}	Setup Time, D to LE	0.5		0		0		ns
t_H	Hold Time, D to LE	0.8		0.5		1.0		
t_W	LE Pulse Width, High	1.5		1.5		1.5		

Capacitance

Symbol	Parameter	Conditions	$T_A = +25^{\circ}\text{C}$ Typical	Units
C_{IN}	Input Capacitance	$V_{DD} = 1.8, 2.5\text{V or } 3.3\text{V}, V_I = 0\text{V or } V_{DD}$	6	pF
C_{OUT}	Output Capacitance	$V_I = 0\text{V or } V_{DD}, V_{DD} = 1.8\text{V}, 2.5\text{V or } 3.3\text{V}$	7	
C_{PD}	Power Dissipation Capacitance	$V_I = 0\text{V or } V_{DD}, F = 10\text{ MHz}$ $V_{DD} = 1.8\text{V}, 2.5\text{V or } 3.3\text{V}$	20	

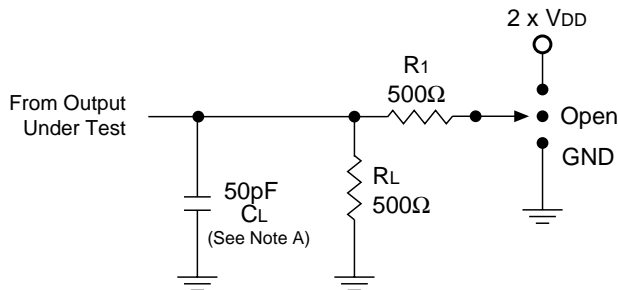
Test Circuits and Switching Waveforms
Parameter Measurement Information ($V_{DD} = 1.8V - 3.6V$)

Switch Position

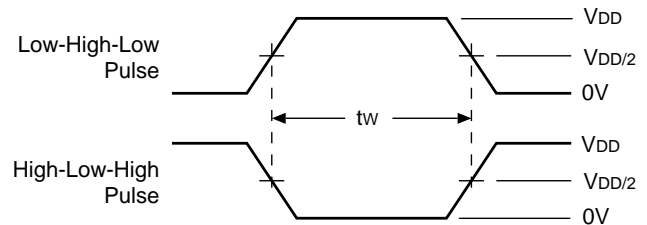
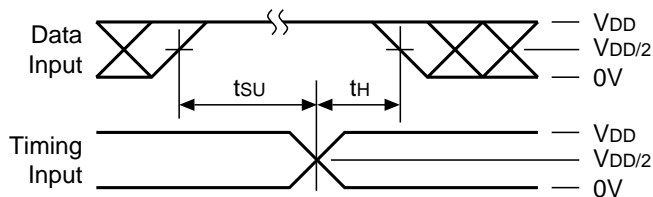
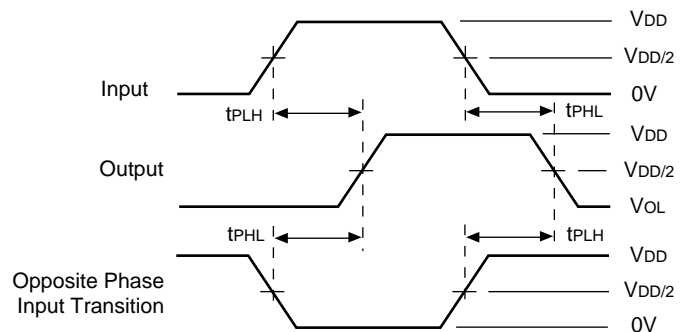
Test	S1
t_{pd}	Open
t_{PLZ}/t_{PZL}	$2 \times V_{DD}$
t_{PHZ}/t_{PZH}	GND

Pulse Width

Setup, Hold, and Release Timing

Propagation Delay

Notes:

- A. C_L includes probe and jig capacitance.
- B. Waveform 1 is for an output with internal conditions such that the output is LOW except when disabled by the output control.
Waveform 2 is for an output with internal conditions such that the output is HIGH except when disabled by the output control.
- C. All input pulses are supplied by generators having the following characteristics: $PRR \leq 10 \text{ MHz}$, $Z_o = 50\Omega$, $t_r \leq 2\text{ns}$, $t_f \leq 2\text{ns}$, **measured from 10% to 90%, unless otherwise specified.**
- D. The outputs are measured one at a time with one transition per measurement.

Enable Disable Timing
