

## 4 x 47W MOSFET quad bridge power amplifier

### Features

- Multipower BCD technology
- High output power capability:
  - 4 x 47W/4Ω max.
  - 4 x 80W/2Ω max.
- MOSFET output power stage
- Excellent 2Ω driving capability
- Hi-fi class distortion
- Low output noise
- St-by function
- Mute function
- Automute at min. supply voltage detection
- Low external component count:
  - Internally fixed gain (26dB)
  - No external compensation
  - No bootstrap capacitors

### Protections:

- Output short circuit to GND, to  $V_S$ , across the load
- Very inductive loads
- Overrating chip temperature with soft thermal limiter
- Load dump voltage

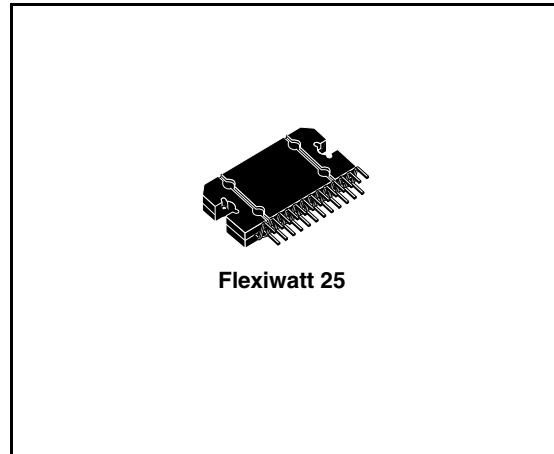

- Fortuitous open GND
- Reversed battery
- ESD

### Description

The TDA7854 is a breakthrough MOSFET technology class AB audio power amplifier in Flexiwatt 25 package designed for high power car radio. The fully complementary P-Channel/N-Channel output structure allows a rail to rail output voltage swing which, combined with high output current and minimized saturation losses sets new power references in the car-radio field, with unparalleled distortion performances.

**Table 1. Device summary**

Order code	Package	Packing
TDA7854	Flexiwatt 25	Tube

---

# Contents

<b>1</b>	<b>Block diagram and application circuit</b> .....	<b>5</b>
1.1	Block diagram .....	5
1.2	Application circuit .....	5
<b>2</b>	<b>Pin description</b> .....	<b>6</b>
2.1	Pin connection .....	6
2.2	Thermal data .....	6
<b>3</b>	<b>Electrical specifications</b> .....	<b>7</b>
3.1	Absolute maximum ratings .....	7
3.2	Electrical characteristics .....	7
<b>4</b>	<b>Application hints</b> .....	<b>9</b>
4.1	SVR .....	9
4.2	Input stage .....	9
4.3	Stand-by and muting .....	9
4.4	Heatsink definition .....	9
<b>5</b>	<b>Package information</b> .....	<b>10</b>
<b>6</b>	<b>Revision history</b> .....	<b>11</b>

## List of tables

Table 2.	Thermal data . . . . .	6
Table 3.	Absolute maximum ratings . . . . .	7
Table 4.	Electrical characteristics . . . . .	7
Table 5.	Document revision history . . . . .	11

---

## List of figures

Figure 1.	Block diagram . . . . .	5
Figure 2.	Application circuit . . . . .	5
Figure 3.	Pin connection (top view) . . . . .	6
Figure 4.	Power dissipation vs. output power ( $R_L = 4\Omega$ , audio program simulation) . . . . .	9
Figure 5.	Flexiwatt25 mechanical data and package dimensions . . . . .	10

# 1 Block diagram and application circuit

## 1.1 Block diagram

Figure 1. Block diagram

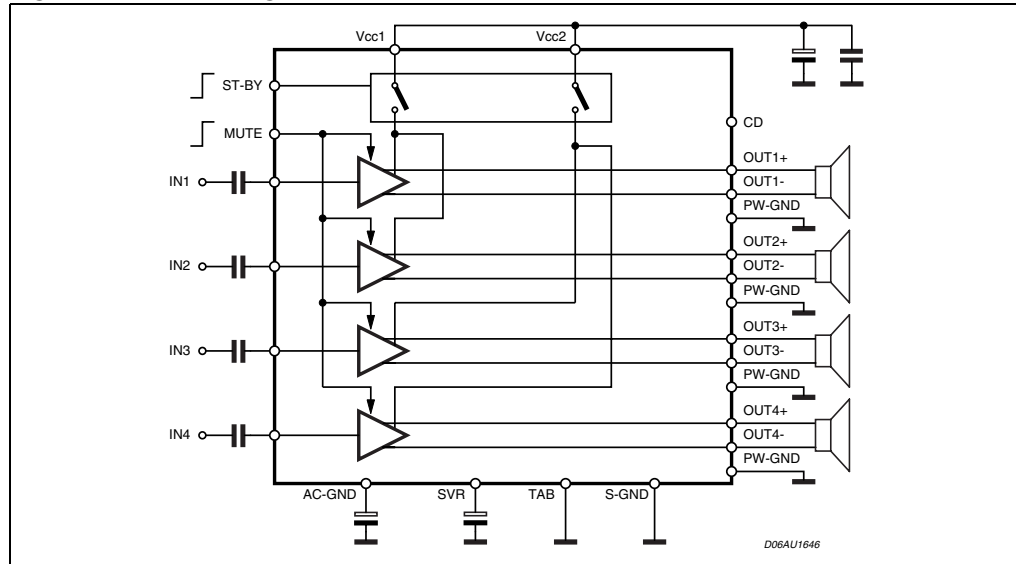

## 1.2 Application circuit

Figure 2. Application circuit

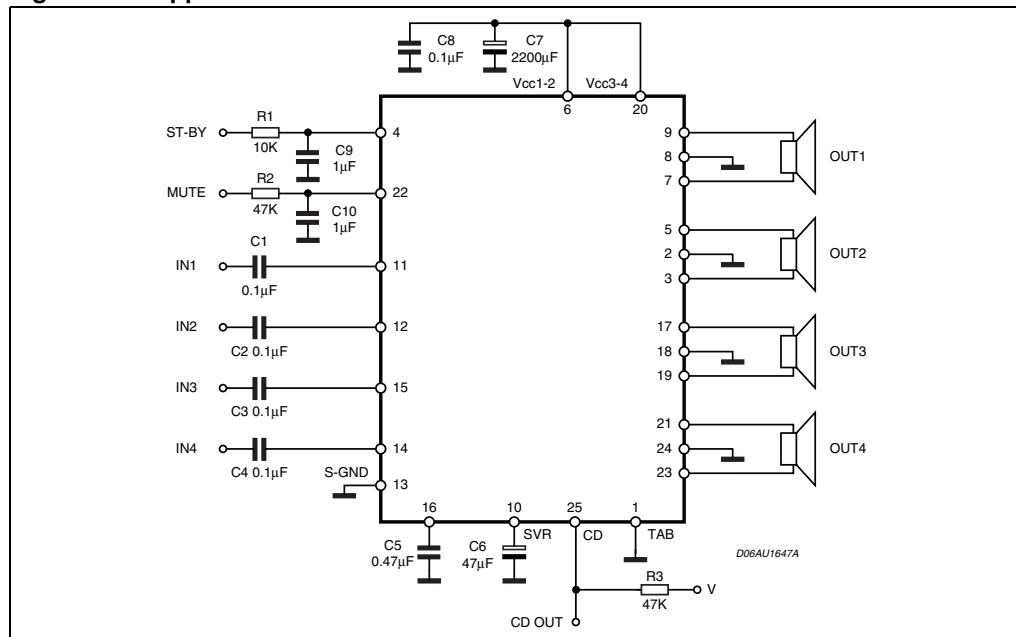

## 2 Pin description

### 2.1 Pin connection

Figure 3. Pin connection (top view)

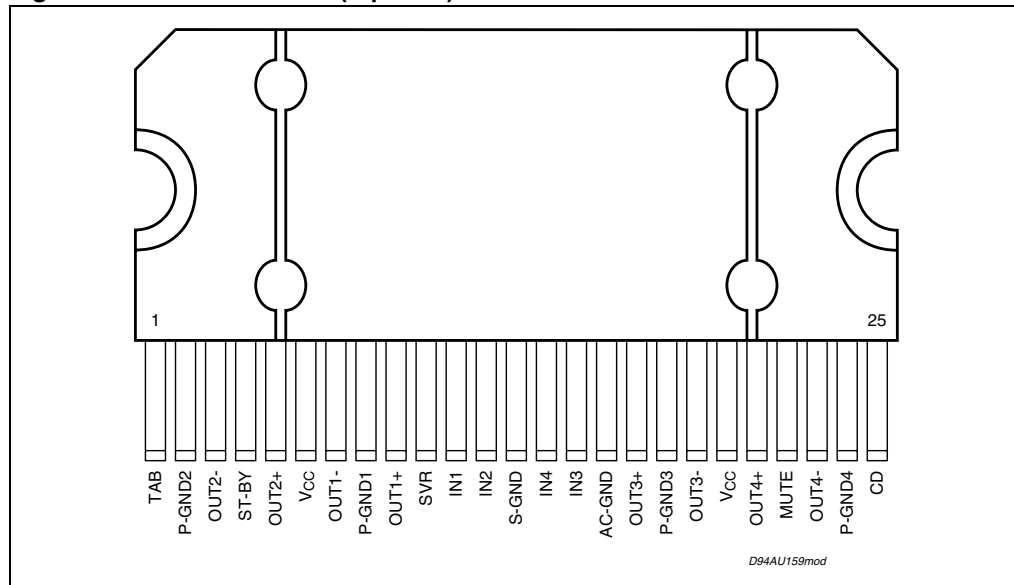

### 2.2 Thermal data

Table 2. Thermal data

Symbol	Parameter	Value	Unit
$R_{th\ j-case}$	Thermal resistance junction to case	max 1	°C/W

### 3 Electrical specifications

#### 3.1 Absolute maximum ratings

Table 3. Absolute maximum ratings

Symbol	Parameter	Value	Unit
$V_S$	Operating supply voltage	18	V
$V_{S(DC)}$	DC supply voltage	28	V
$V_{S(pk)}$	Peak supply voltage (for $t = 50ms$ )	50	V
$I_O$	Output peak current Non repetitive ( $t = 100\mu s$ )	10	A
	Repetitive (duty cycle 10% at $f = 10Hz$ )	9	A
$P_{tot}$	Power dissipation $T_{case} = 70^\circ C$	85	W
$T_j$	Junction temperature	150	$^\circ C$
$T_{stg}$	Storage temperature	-55 to 150	$^\circ C$

#### 3.2 Electrical characteristics

Table 4. Electrical characteristics

(Refer to the test and application diagram,  $V_S = 14.4V$ ;  $R_L = 4\Omega$ ;  $R_g = 600\Omega$ ;  $f = 1KHz$ ;  $T_{amb} = 25^\circ C$ ; unless otherwise specified).

Symbol	Parameter	Test condition	Min.	Typ.	Max.	Unit
$I_{q1}$	Quiescent current	$R_L = \infty$	100	150	250	mA
$V_{OS}$	Output offset voltage	Play mode / Mute mode	-60		+60	mV
$G_v$	Voltage gain		25	26	27	dB
$dG_v$	Channel gain unbalance				$\pm 1$	dB
$P_o$	Output power	$V_S = 14.4V$ ; THD = 10%		28		W
		$V_S = 14.4V$ ; THD = 1%		22		W
		$V_S = 14.4V$ ; THD = 10%, $2\Omega$		48		W
		$V_S = 14.4V$ ; THD = 1%, $2\Omega$		38		W
$P_{o max.}$	Max. output power <sup>(1)</sup>	$V_S = 15.2V$ ; $R_L = 4\Omega$		47		W
		$V_S = 15.2V$ ; $R_L = 2\Omega$		80		W
THD	Distortion	$P_o = 4W$		0.01		%
$e_{No}$	Output Noise	"A" Weighted		35		$\mu V$
		Bw = 20Hz to 20KHz		50	100	$\mu V$
SVR	Supply voltage rejection	$f = 100Hz$ ; $V_r = 1V_{rms}$	50	70		dB
$f_{ch}$	High cut-off frequency	$P_o = 0.5W$	100	300		KHz
$R_i$	Input Impedance		80	100	120	K $\Omega$

**Table 4. Electrical characteristics (continued)**

(Refer to the test and application diagram,  $V_S = 14.4V$ ;  $R_L = 4\Omega$ ;  $R_G = 600\Omega$ ;  $f = 1KHz$ ;  
 $T_{amb} = 25^\circ C$ ; unless otherwise specified).

Symbol	Parameter	Test condition	Min.	Typ.	Max.	Unit
$C_T$	Cross Talk	$f = 1KHz P_O = 4W$	60	70	-	dB
		$f = 10KHz P_O = 4W$		60	-	dB
$I_{SB}$	St-by current consumption	$V_{St-By} = 0$			10	$\mu A$
$I_{pin5}$	St-by pin current	$V_{St-By} = 1.2V$ to $2.65V$			$\pm 1$	$\mu A$
$V_{SB out}$	St-by out threshold voltage	(Amp: ON)	2.65			V
$V_{SB in}$	St-by in threshold voltage	(Amp: OFF)			1.2	V
$A_M$	Mute attenuation	$P_{Oref} = 4W$	80	90		dB
$V_{M out}$	Mute out threshold voltage	(Amp: Play)	2.6			V
$V_{M in}$	Mute in threshold voltage	(Amp: Mute)			1.2	V
$V_{AM in}$	VS automute threshold	(Amp: Mute) $Att \geq 80dB$ ; $P_{Oref} = 4W$	6.8	7		V
		(Amp: Play) $Att < 0.1dB$ ; $P_O = 0.5W$		7.5	8	V
$I_{pin23}$	Muting pin current	$V_{MUTE} = 1.2V$ (Sourced current)	7	12	18	$\mu A$
		$V_{MUTE} = 2.6V$	-5		18	$\mu A$
<b>CLIPPING DETECTOR</b>						
$CD_{LK}$	Clip Det high leakage current	Cd Off		0	1	$\mu A$
$CD_{SAT}$	Clip Det sat voltage	DC On; $I_{CD} = 1mA$		0.2	0.4	V
$CD_{THD}$	Clip Det THD level			2		%

1. Saturated square wave output



## 4 Application hints

### 4.1 SVR

Besides its contribution to the ripple rejection, the SVR capacitor governs the turn ON/OFF time sequence and, consequently, plays an essential role in the pop optimization during ON/OFF transients. To conveniently serve both needs, **its minimum recommended value is 10 $\mu$ F.**

### 4.2 Input stage

The TDA7854's inputs are ground-compatible and can stand very high input signals ( $\pm 8$ Vpk) without any performances degradation.

If the standard value for the input capacitors (0.1 $\mu$ F) is adopted, the low frequency cut-off will amount to 16 Hz.

### 4.3 Stand-by and muting

R-C cells have always to be used in order to smooth down the transitions for preventing any audible transient noise.

About stand-by, the time constant to be assigned in order to obtain a virtually pop-free transition has to be slower than 2.5V/ms.

A direct connection to Vs of these two pins is admissible but a 470kOhm equivalent resistance should be present between the power supply and muting and stand-by pins.

### 4.4 Heatsink definition

Under normal usage (4 Ohm speakers) the heatsink's thermal requirements have to be deduced from [Figure 4](#), which reports the simulated power dissipation when real music/speech programmes are played out. Noise with gaussian-distributed amplitude was employed for this simulation. Based on that, frequent clipping occurrence (worst-case) will cause  $P_{diss} = 26$ W. Assuming  $T_{amb} = 70^{\circ}\text{C}$  and  $T_{CHIP} = 150^{\circ}\text{C}$  as boundary conditions, the heatsink's thermal resistance should be approximately  $2^{\circ}\text{C/W}$ . This would avoid any thermal shutdown occurrence even after long-term and full-volume operation.

**Figure 4. Power dissipation vs. output power ( $R_L = 4\Omega$ , audio program simulation)**

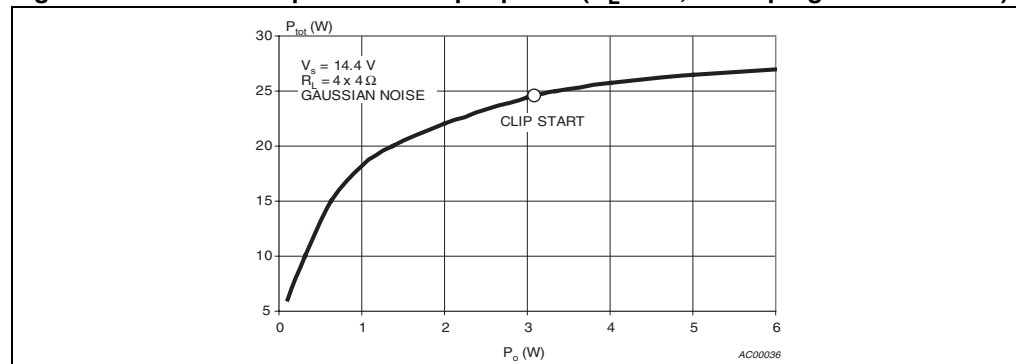

## 5 Package information

In order to meet environmental requirements, ST offers this device in ECOPACK® packages. This package has a Lead-free second level interconnect. The category of second level interconnect is marked on the package and on the inner box label, in compliance with JEDEC Standard JESD97. The maximum ratings related to soldering conditions are also marked on the inner box label.

ECOPACK is an ST trademark. ECOPACK specifications are available at: [www.st.com](http://www.st.com).

**Figure 5. Flexiwatt25 mechanical data and package dimensions**

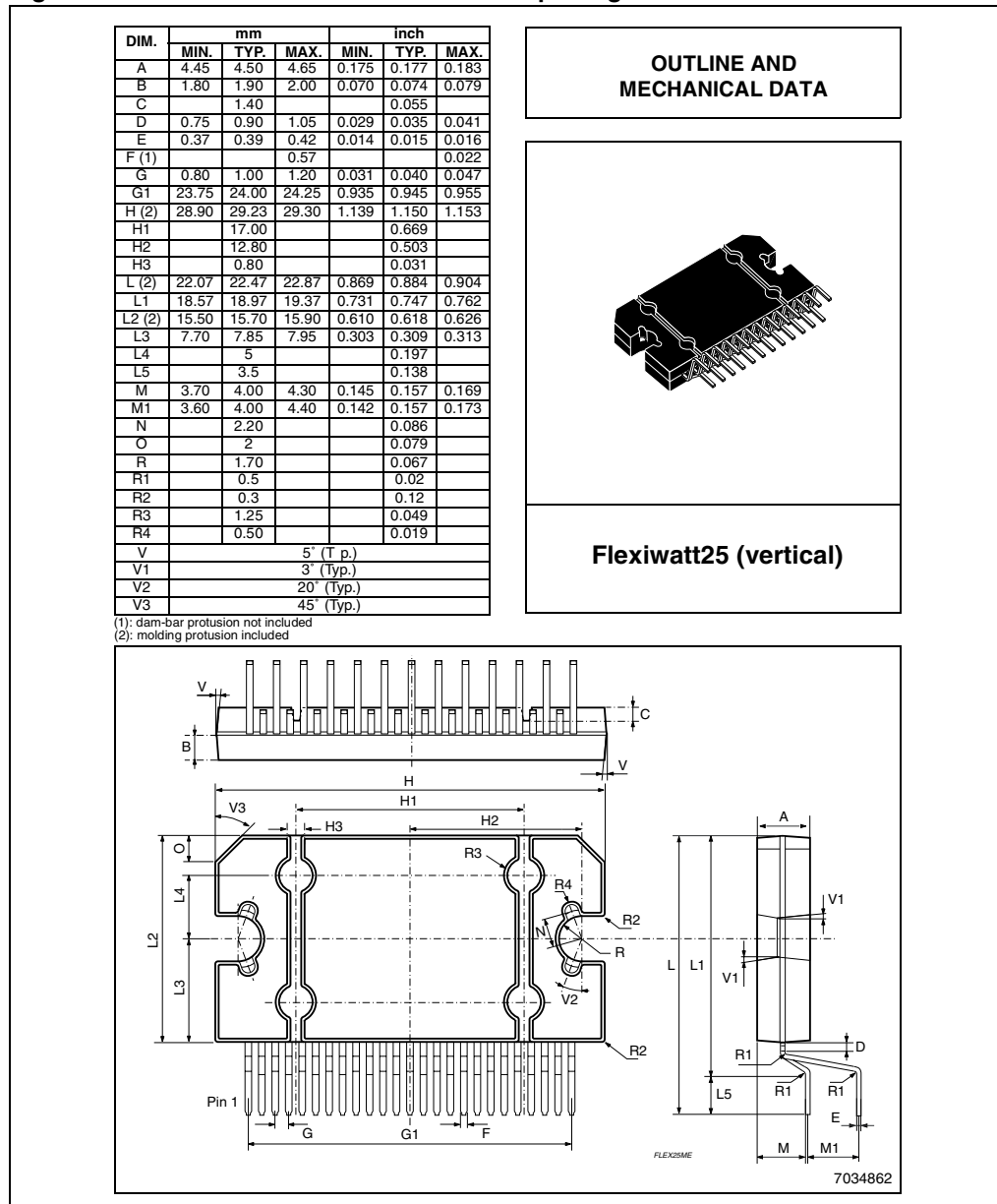

## 6 Revision history

Table 5. Document revision history

Date	Revision	Changes
4-Oct-2007	1	Initial release.

**Please Read Carefully:**

Information in this document is provided solely in connection with ST products. STMicroelectronics NV and its subsidiaries ("ST") reserve the right to make changes, corrections, modifications or improvements, to this document, and the products and services described herein at any time, without notice.

All ST products are sold pursuant to ST's terms and conditions of sale.

Purchasers are solely responsible for the choice, selection and use of the ST products and services described herein, and ST assumes no liability whatsoever relating to the choice, selection or use of the ST products and services described herein.

No license, express or implied, by estoppel or otherwise, to any intellectual property rights is granted under this document. If any part of this document refers to any third party products or services it shall not be deemed a license grant by ST for the use of such third party products or services, or any intellectual property contained therein or considered as a warranty covering the use in any manner whatsoever of such third party products or services or any intellectual property contained therein.

**UNLESS OTHERWISE SET FORTH IN ST'S TERMS AND CONDITIONS OF SALE ST DISCLAIMS ANY EXPRESS OR IMPLIED WARRANTY WITH RESPECT TO THE USE AND/OR SALE OF ST PRODUCTS INCLUDING WITHOUT LIMITATION IMPLIED WARRANTIES OF MERCHANTABILITY, FITNESS FOR A PARTICULAR PURPOSE (AND THEIR EQUIVALENTS UNDER THE LAWS OF ANY JURISDICTION), OR INFRINGEMENT OF ANY PATENT, COPYRIGHT OR OTHER INTELLECTUAL PROPERTY RIGHT.**

**UNLESS EXPRESSLY APPROVED IN WRITING BY AN AUTHORIZED ST REPRESENTATIVE, ST PRODUCTS ARE NOT RECOMMENDED, AUTHORIZED OR WARRANTED FOR USE IN MILITARY, AIR CRAFT, SPACE, LIFE SAVING, OR LIFE SUSTAINING APPLICATIONS, NOR IN PRODUCTS OR SYSTEMS WHERE FAILURE OR MALFUNCTION MAY RESULT IN PERSONAL INJURY, DEATH, OR SEVERE PROPERTY OR ENVIRONMENTAL DAMAGE. ST PRODUCTS WHICH ARE NOT SPECIFIED AS "AUTOMOTIVE GRADE" MAY ONLY BE USED IN AUTOMOTIVE APPLICATIONS AT USER'S OWN RISK.**

Resale of ST products with provisions different from the statements and/or technical features set forth in this document shall immediately void any warranty granted by ST for the ST product or service described herein and shall not create or extend in any manner whatsoever, any liability of ST.

ST and the ST logo are trademarks or registered trademarks of ST in various countries.

Information in this document supersedes and replaces all information previously supplied.

The ST logo is a registered trademark of STMicroelectronics. All other names are the property of their respective owners.

© 2007 STMicroelectronics - All rights reserved

STMicroelectronics group of companies

Australia - Belgium - Brazil - Canada - China - Czech Republic - Finland - France - Germany - Hong Kong - India - Israel - Italy - Japan - Malaysia - Malta - Morocco - Singapore - Spain - Sweden - Switzerland - United Kingdom - United States of America

[www.st.com](http://www.st.com)