

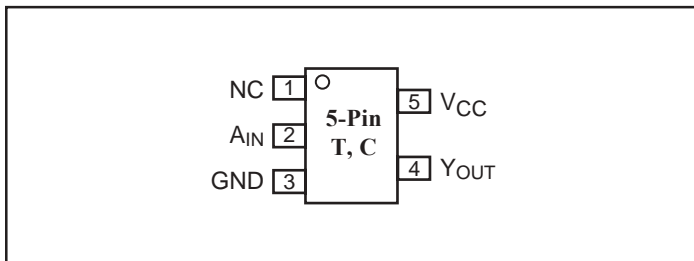
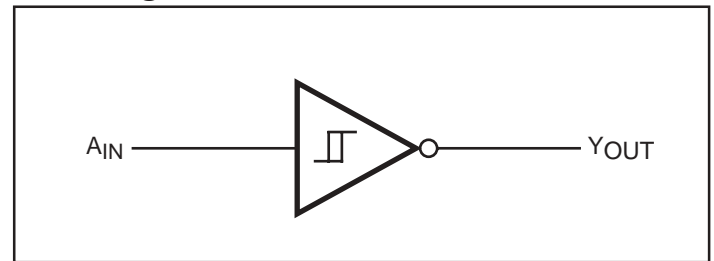
**Features**

- High-speed:  $t_{PD} = 2.7\text{ns}$  typical into  $50\text{pF}$  @  $5\text{V } V_{CC}$
- Broad operating range:  $V_{CC} = 1.65\text{V} - 5.5\text{V}$
- Power down high-impedance inputs/outputs
- High output drive:  $\pm 24\text{mA}$  at  $3\text{V } V_{CC}$
- Package: 5-pin space saving SOT23 and SC70

**Description**

The PI74STX1G14 is a Schmitt-Trigger inverter that operates over the  $1.65\text{V}$  to  $5.5\text{V } V_{CC}$  operating range.

Pericom's PI74STX series of products are produced using the Company's advanced submicron technology.

**Pinout**

**Block Diagram**

**Pin Description**

Pin Names	Description
$A_{IN}$	Input
$Y_{OUT}$	Output

**Recommended Operating Conditions<sup>(1)</sup>**

Parameter	Condition	Min.	Max.	Units
Supply Voltage ( $V_{CC}$ )		1.65	5.5	V
Input Voltage ( $V_{IN}$ )		0	5.5	
Output Voltage ( $V_{OUT}$ )		0	$V_{CC}$	
Operating Temperature		-40	85	°C
Input Rise and Fall Time ( $t_r, t_f$ )	$V_{CC} = 1.8\text{V}, 2.5\text{V} \pm 0.2\text{V}$	0	20	ns/V
	$V_{CC} = 3.3\text{V}, \pm 0.3\text{V}$	0	10	
	$V_{CC} = 5.0\text{V}, \pm 0.5\text{V}$	0	5	

**Function Table**

Inputs	Output
$A_{IN}$	$Y_{OUT}$
L	H
H	L

**Note:**

H = HIGH Logic Level  
L = LOW Logic Level

**Note:**

1. Unused inputs must be held HIGH or LOW. They may not float.

### Absolute Maximum Ratings

Supply Voltage ( $V_{CC}$ ) .....	-0.5V to +6V	DC $V_{CC}/GND$ Current ( $I_{CC}/I_{GND}$ ) .....	±50mA
DC Input Voltage ( $V_{IN}$ ) .....	-0.5V to +6V	Storage Temperature ( $T_{STG}$ ) .....	-65°C to +150°C
DC Output Voltage ( $V_{OUT}$ ) .....	-0.5V to +6V	Junction Lead Temperature (IOS) .....	200°C
DC Input Diode Current ( $I_{IK}$ ) .....	-50mA to 20mA	Power Dissipation SOT23 .....	200mW
DC Output Diode Current ( $I_{OK}$ ) .....	-50mA to 20mA	SC70 .....	150mW
DC Output Current ( $I_{OUT}$ ) .....	±50mA		

**Note:**

Absolute maximum ratings are DC values beyond which the device may be damaged or have its useful life impaired. The datasheet specifications should be met, without exception, to ensure that the system design is reliable over its power supply, temperature, and output/input loading variables. Pericom does not recommend operation outside datasheet specifications.

### DC Electrical Characteristics (Over supply voltage and operating temperature ranges, unless otherwise specified)

Symbol	Parameter	$V_{CC}$ (V)	Conditions		$T_A = +25^\circ\text{C}$			$T_A = -40 \text{ to } +85^\circ\text{C}$		Units
					Min.	Typ.	Max.	Min.	Max.	
$V_P$	Positive Threshold Voltage	1.65			0.6		1.4	0.6	1.4	V
		1.8			0.7		1.5	0.7	1.5	
		2.3			1.0		1.8	1.0	1.8	
		3.0			1.3		2.2	1.3	2.2	
		4.5			1.9		3.1	1.9	3.1	
		5.5			2.2		3.6	2.2	3.6	
$V_N$	Negative Threshold Voltage	1.65			0.2	0.50	0.8	0.2	0.8	V
		1.8			0.25	0.56	0.9	0.25	0.9	
		2.3			0.40	0.75	1.15	0.40	1.15	
		3.0			0.6	0.98	1.5	0.6	1.5	
		4.5			1.0	1.42	2.0	1.0	2.0	
		5.5			1.2	1.68	2.3	1.2	2.3	
$V_H$	Hysteresis Voltage	1.65			0.1	0.48	0.9	0.1	0.9	V
		1.8			0.15	0.51	1.0	0.15	1.0	
		2.3			0.25	0.62	1.1	0.25	1.1	
		3.0			0.3	0.76	1.2	0.3	1.2	
		4.5			0.6	1.01	1.5	0.6	1.5	
		5.5			0.7	1.20	1.7	0.7	1.7	
$V_{OH}$	HIGH Level Output Voltage	1.65	$V_{IN} = V_{IL}$	$I_{OH} = -100\mu\text{A}$	1.55	1.65		1.55		V
		1.8			1.7	1.8	1.7			
		2.3			2.2	2.3	2.2			
		3.0			2.9	3.0	2.9			
		4.5			4.4	4.5	4.4			
		1.65				$I_{OH} = -4\text{mA}$	1.29	1.52		
	2.3		$I_{OH} = -8\text{mA}$	1.9	2.14		1.9			
	3.0		$I_{OH} = -16\text{mA}$	2.4	2.75		2.4			
	3.0		$I_{OH} = -24\text{mA}$	2.3	2.62		2.3			
	4.5		$I_{OH} = -32\text{mA}$	3.8	4.13		3.8			

### DC Electrical Characteristics (continued)

(Over supply voltage and operating temperature ranges, unless otherwise specified) (continued)

Symbol	Parameter	V <sub>CC</sub> (V)	Conditions		T <sub>A</sub> = +25°C			T <sub>A</sub> = -40 to +85°C		Units
					Min.	Typ.	Max.	Min.	Max.	
V <sub>OL</sub>	LOW Level Output Voltage	1.65	V <sub>IN</sub> = V <sub>IH</sub>	I <sub>OL</sub> = 100μA		0.00	0.1		0.1	V
		1.8			0.00	0.1	0.1			
		2.3			0.00	0.1	0.1			
		3.0			0.00	0.1	0.1			
		4.5			0.00	0.1	0.1			
		1.65	I <sub>OL</sub> = 4mA I <sub>OL</sub> = 8mA I <sub>OL</sub> = 16mA I <sub>OL</sub> = 24mA I <sub>OL</sub> = 32mA		0.08	0.24	0.24			
		2.3		0.10	0.3	0.3				
		3.0		0.16	0.4	0.4				
		3.0		0.24	0.55	0.55				
		4.5		0.25	0.55	0.55				
I <sub>IN</sub>	Input Leakage Current	0 to 5.5	V <sub>IN</sub> = 5.5V, GND				±1	±10	μA	
I <sub>OFF</sub>	Power Off Leakage Current	0.0	V <sub>IN</sub> or V <sub>OUT</sub> = 5.5V		-1		1	-1		1
I <sub>CC</sub>	Quiescent Supply Current	1.65-5.5	V <sub>IN</sub> = 5.5V, GND				2.0			20

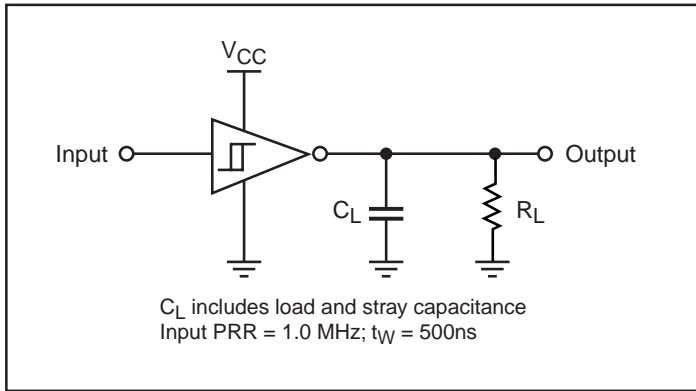
### AC Electrical Characteristics

Symbol	Parameter	V <sub>CC</sub> (V)	Conditions		T <sub>A</sub> = +25°C			T <sub>A</sub> = -40°C to +85°C		Units	Fig. No.
					Min.	Typ.	Max.	Min.	Max.		
t <sub>PLH</sub> , t <sub>PHL</sub>	Propagation Delay	1.8 ±0.15	C <sub>L</sub> = 15pF, R <sub>L</sub> = 1 Mohm	0.7	5.7	6.6	0.7	7.3	ns	1 3	
		2.5 ±0.2		0.5	3.4	4.2	0.5	4.6			
		3.3 ±0.3		0.5	2.6	3.3	0.5	3.6			
		5.0 ±0.5		0.5	2.1	2.5	0.5	2.8			
t <sub>PLH</sub> , t <sub>PHL</sub>	Propagation Delay	3.3 ±0.3	C <sub>L</sub> = 50pF, R <sub>L</sub> = 500 ohms	0.5	3.5	4.6	0.5	5.1	pF	1 3	
		5.0 ±0.5		0.5	2.7	3.6	0.5	4.0			
C <sub>IN</sub>	Input Capacitance	0			4						
C <sub>PD</sub>	Power Dissipation Capacitance <sup>(3)</sup>	3.3			6.3					2	
		5.0			9.5						

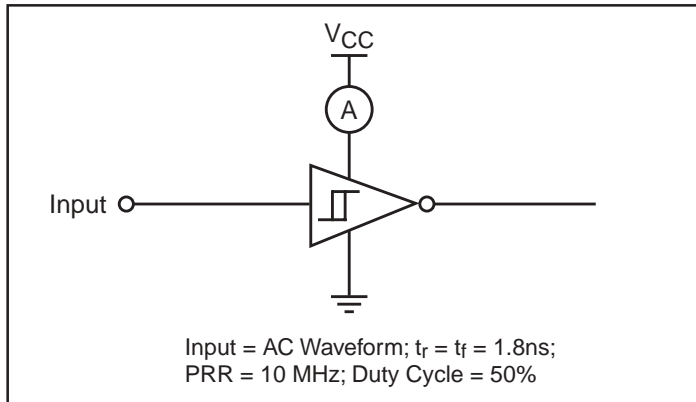
#### Notes:

3. C<sub>PD</sub> is defined as the value of the internal equivalent capacitance which is derived from dynamic operating current consumption (I<sub>CCD</sub>) at no output loading and operating at 50% duty cycle (see Figure 2). C<sub>PD</sub> is related to I<sub>CCD</sub> dynamic operating current by the expression: I<sub>CCD</sub> = (C<sub>PD</sub>)(V<sub>CC</sub>)(f<sub>IN</sub>) + (I<sub>CC</sub> static).

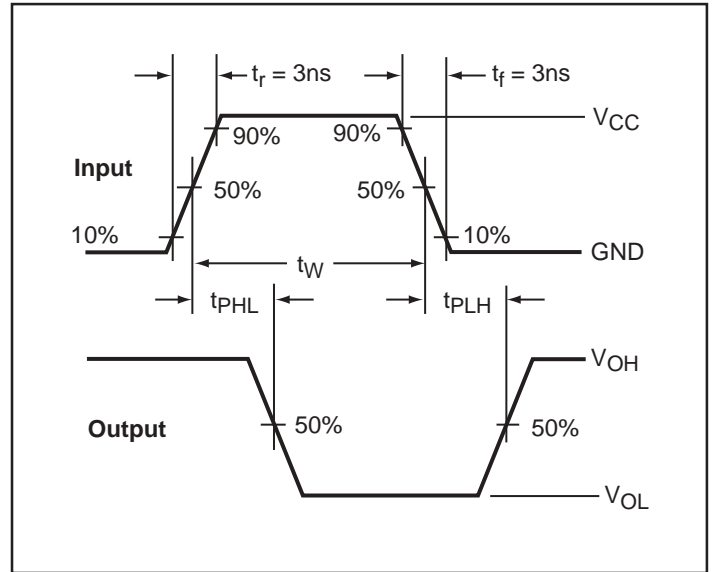
### AC Loading and Waveforms



**Figure 1. AC Test Circuit**

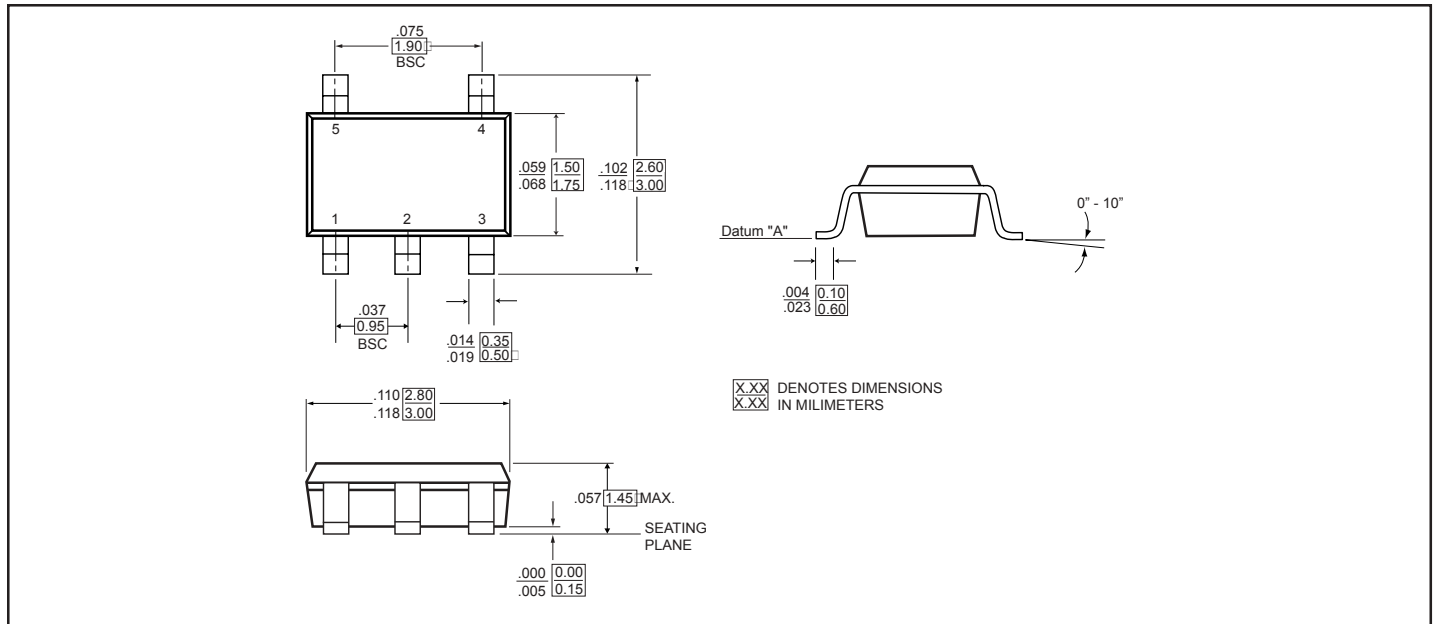


**Figure 2. ICCD Test Circuit**

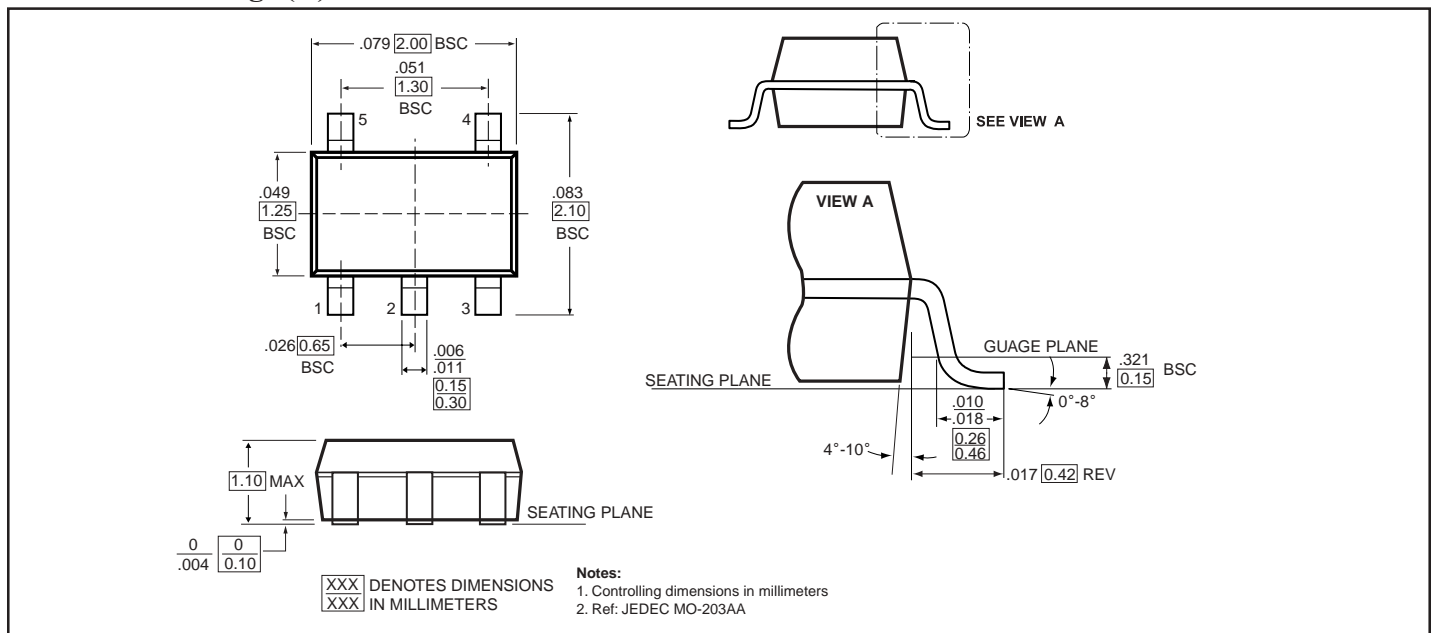


**Figure 3. AC Waveforms**

### 5-Pin SOT23 (T) Package



### 5-Pin SC70 Package (C)



### Ordering Information

Part	Pin-Package	Top Marking	Operating Range
PI74STX1G14TX	5-Pin - SOT23	M14	-40°C to 85°C
PI74STX1G14CX	5-Pin - SC70	M14	-40°C to 85°C