

Low power single inverter gate

Features

- High speed: $t_{PD} = 4.3$ ns (max.) at $V_{CC} = 2.3$ V
- Power down protection on inputs and outputs
- Balanced propagation delays:
 $t_{PLH} \approx t_{PHL}$
- Operating voltage range:
 V_{CC} (opr) = 1.2 to 3.6 V
- Low power dissipation:
 $I_{CC} = 1$ μ A (max.) at $T_A = 85$ °C
- Latch-up performance exceeds 300 mA (JESD 78, Class II)
- ESD performance:
 - 2000-V Human-Body Model (A114-A)
 - 200-V Machine Model (A115-A)
 - 1000-V Charged-Device Model (C101)

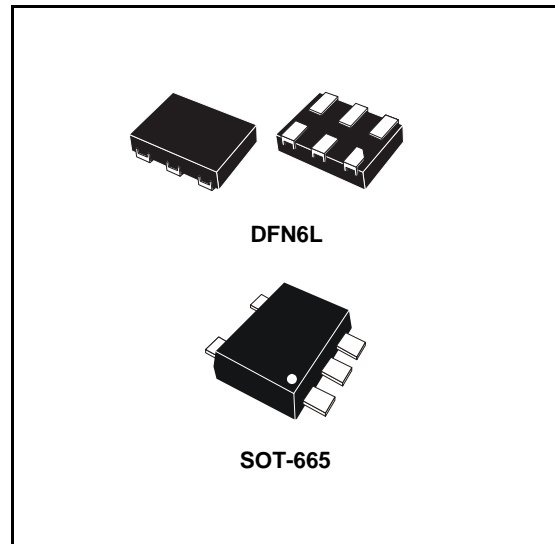

Applications

- Mobile phones
- Personal digital assistants (PDAs)

Description

The 74AUP1G04 is a low voltage CMOS single inverter gate fabricated with sub-micron silicon gate and double-layer metal wiring C²MOS technology. It is ideal for 1.2 to 3.6 V operations and low power and low noise applications.

All inputs and outputs are equipped with protection circuits against static discharge, giving them 2kV ESD immunity and transient excess voltage.

Table 1. Device summary

Order code	Package	Packing
74AUPG04DTR	DFN6L (1.2 x 1 mm)	Tape and reel
74AUPG04GTR	SOT-665 (1.6 x 1.6 mm)	Tape and reel

1 Pin settings

1.1 Pin connection

Figure 1. Pin connection (top through view)

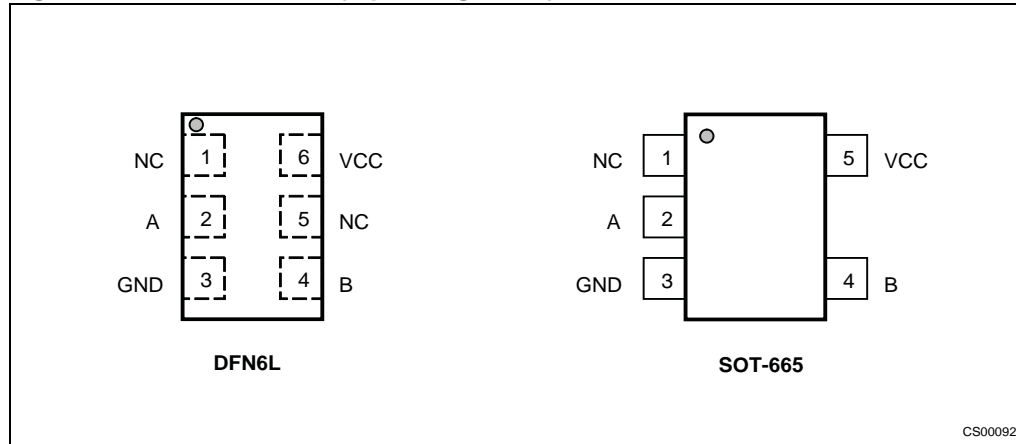

CS00092

1.2 Pin description

Table 2. Pin assignment

DFN pin number	SOT pin number	Symbol	Name and function
1	1	NC	Not connected
2	2	A	Data input
3	3	GND	Ground (0V)
4	4	B	Data output
5	-	NC	Not connected
6	5	V _{CC}	Positive supply voltage

1.3 Truth table

Figure 2. Truth table

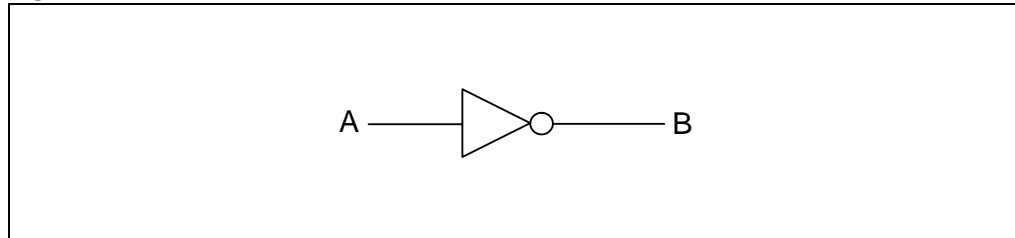
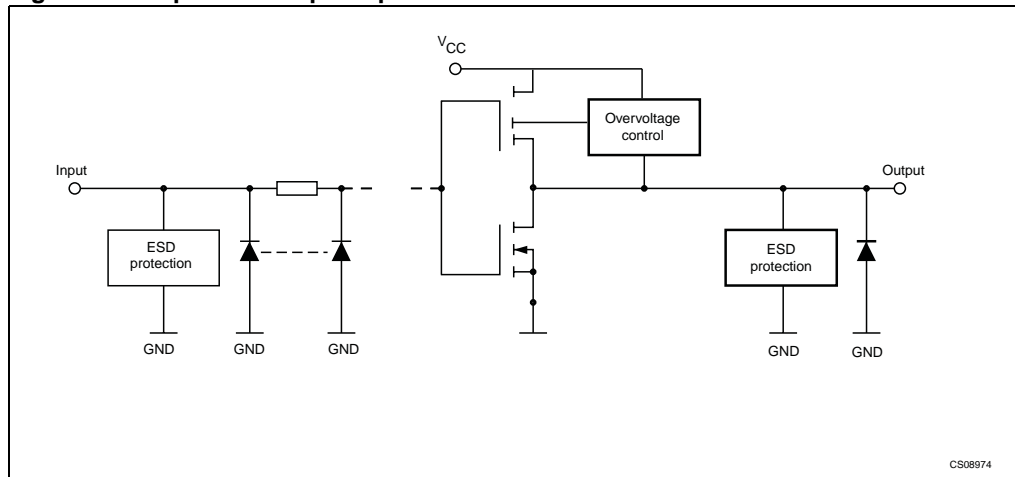

Table 3. Truth table

A	B
L	H
H	L

Figure 3. Input and output equivalent circuit



2 Maximum rating

Stressing the device above the rating listed in the “absolute maximum ratings” table may cause permanent damage to the device. These are stress ratings only and operation of the device at these or any other conditions above those indicated in the operating sections of this specification is not implied. Exposure to absolute maximum rating conditions for extended periods may affect device reliability. Refer also to the STMicroelectronics SURE Program and other relevant quality documents.

Table 4. Absolute maximum ratings

Symbol	Parameter	Value	Unit
V_{CC}	Supply voltage	-0.5 to +4.6	V
V_I	DC input voltage	-0.5 to +4.6	V
V_O	DC output voltage ($V_{CC} = 0$ V)	-0.5 to +4.6	V
V_O	DC output voltage (high or low state)	-0.5 to $V_{CC} + 0.5$	V
I_{IK}	DC input diode current	-20	mA
I_{OK}	DC output diode current	-50	mA
I_O	DC output current	± 50	mA
I_{CC}	DC supply current per supply pin	± 100	mA
I_{GND}	DC ground current per supply pin	± 100	mA
P_D	Power dissipation	200	mW
T_{stg}	Storage temperature	-65 to +150	°C
T_L	Lead temperature (10 sec)	260	°C

2.1 Recommended operating conditions

Table 5. Recommended operating conditions

Symbol	Parameter	Value	Unit	
V_{CC}	Supply voltage	1.2 to 3.6	V	
V_I	Input voltage	0 to V_{CC}	V	
V_O	Output voltage	0 to V_{CC}	V	
T_{op}	Operating temperature	-40 to 85	°C	
dt/dv	Input rise and fall time	$V_{CC} = 3.0$ to 3.6 V	10	ns/V
		$V_{CC} = 2.3$ to 2.7 V	20	ns/V
		$V_{CC} = 1.2$ to 1.95 V	100	ns/V

3 Electrical characteristics

Table 6. DC specifications

Symbol	Parameter	V _{CC} (V)	Test condition	Value		Value		Unit
				25 °C		-40 to 85 °C		
				Min	Max	Min	Max	
V _{IH}	High level input voltage	1.2 to 1.95		0.65 V _{CC}		0.65 V _{CC}		V
		2.0 to 2.7		1.6		1.6		
		2.75 to 3.6		2.0		2.0		
V _{IL}	Low level input voltage	1.2 to 1.95			0.35 V _{CC}		0.35V _{CC}	V
		2.0 to 2.7			0.7		0.7	
		2.75 to 3.6			0.8		0.8	
V _{OH}	High level output voltage	1.2 to 3.6	I _{OH} = -100 μA	V _{CC} - 0.2		V _{CC} - 0.2		V
		3.0	I _{OH} = -10 mA	2.45		2.4		
		2.3	I _{OH} = -6 mA	1.85		1.8		
		1.65	I _{OH} = -4 mA	1.30		1.25		
		1.4	I _{OH} = -2 mA	1.10		1.05		
		1.2	I _{OH} = -1 mA	1.00		0.95		
V _{OL}	Low level output voltage	1.2 to 3.6	I _O = 100 μA		0.15		0.20	V
		3.0	I _O = 10 mA		0.50		0.55	
		2.3	I _O = 6 mA		0.35		0.40	
		1.65	I _O = 4 mA		0.35		0.40	
		1.4	I _O = 2 mA		0.25		0.30	
		1.2	I _O = 1 mA		0.20		0.25	
I _I	Input leakage current	0 to 3.6	V _I = GND to 3.6		±0.1		±0.5	μA
I _{off}	Power off leakage current	0	V _I or V _O = 0 to 3.6 V		±0.1		±1.0	μA
I _{CC}	Quiescent supply current	1.2 to 3.6	V _I = V _{CC} or GND		0.1		1	μA
ΔI _{CC}	I _{CC} increment per input	3.3	V _I = V _{CC} - 0.6V, I _O = 0		80		100	μA

Table 7. AC electrical characteristics

Symbol	Parameter	V _{CC} (V)	Test condition	Value			Unit
				C _L (pF)	25 °C	-40 to 85 °C	
			Typ		Min	Max	
t _{PLH} , t _{PHL}	Propagation delay time	1.1 to 1.3	5	8.0		12.4	ns
		1.4 to 1.6		4.2		6.6	
		1.65 to 1.95		3.2		5.1	
		2.3 to 2.7		2.3		3.1	
		3.0 to 3.6		1.9		2.5	
		1.1 to 1.3	10	8.6		13	
		1.4 to 1.6		4.6		7	
		1.65 to 1.95		3.5		5.3	
		2.3 to 2.7		2.4		3.5	
		3.0 to 3.6		2.0		2.9	
		1.1 to 1.3	15	9.1		13.3	
		1.4 to 1.6		5.6		7.5	
		1.65 to 1.95		3.8		5.7	
		2.3 to 2.7		2.6		3.7	
		3.0 to 3.6		2.2		3.1	
		1.1 to 1.3	30	10.5		16	
		1.4 to 1.6		5.5		9	
		1.65 to 1.95		4.3		6.7	
		2.3 to 2.7		3.1		4.3	
		3.0 to 3.6		2.7		3.8	

Table 8. Capacitive characteristics

Symbol	Parameter	V _{CC} (V)	Test condition	Value			Unit
				T _A = 25 °C			
				Min	Typ	Max	
C _I	Input capacitance	0	V _I = 0 or V _{CC}		3		pF
		3.6	V _I = 0 or V _{CC}		6		
C _O	Output capacitance	3.6	V _I = 0 or V _{CC}		6		pF
C _{PD}	Power dissipation capacitance	3.6	f = 10 MHz		32		pF

4 Test circuit

Figure 4. Test circuit

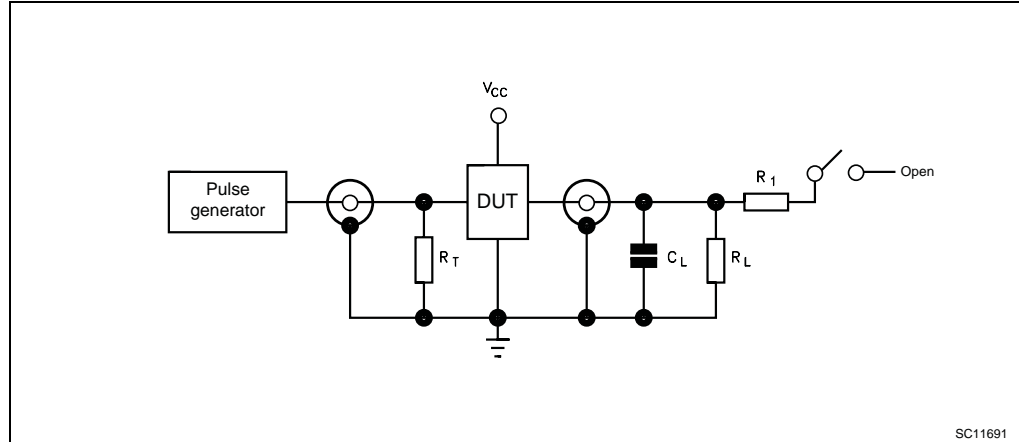

Table 9. Test setting

Test	Switch
t_{PLH} , t_{PHL}	Open

Table 10. Symbol and values for test circuit and waveform

Symbol	V_{CC}				
	$1.2 \pm 0.1 \text{ V}$	$1.5 \pm 0.1 \text{ V}$	$1.8 \pm 0.15 \text{ V}$	$2.5 \pm 0.2 \text{ V}$	$3.3 \pm 0.3 \text{ V}$
C_L	5, 10, 15, 30 pF	5, 10, 15, 30 pF	5, 10, 15, 30 pF	5, 10, 15, 30 pF	5, 10, 15, 30 pF
R_L	500 Ω	500 Ω	500 Ω	500 Ω	500 Ω
V_M	$V_{CC}/2$	$V_{CC}/2$	$V_{CC}/2$	$V_{CC}/2$	1.5
V_{IH}	V_{CC}	V_{CC}	V_{CC}	V_{CC}	V_{CC}
$t_r = t_f$	$\leq 2 \text{ ns}$	$\leq 2 \text{ ns}$	$\leq 2 \text{ ns}$	$\leq 2 \text{ ns}$	$\leq 2 \text{ ns}$

$R_T = Z_{OUT}$ of pulse generator (typically 50 Ω)

Figure 5. Waveform: propagation delay (f = 1 MHz; 50% duty cycle)

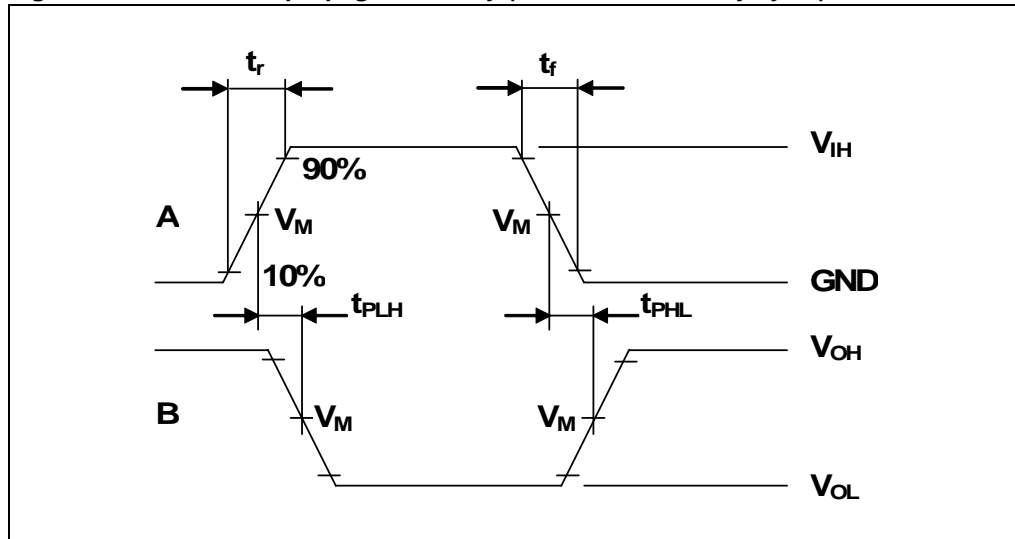

Table 11. DFN6L (1.2 x 1 mm) package mechanical data

Symbol	Millimeters		
	Typ	Min	Max
A	0.50	0.45	0.55
A1	0.02	0	0.05
A3	0.127		
b	0.20	0.15	0.25
D	1.20	1.15	1.25
E	1	0.95	1.05
e	0.40		
L	0.35	0.30	0.40
L1	0.45	0.40	0.50

Figure 7. DFN6L (1.2 x 1 mm) package footprint

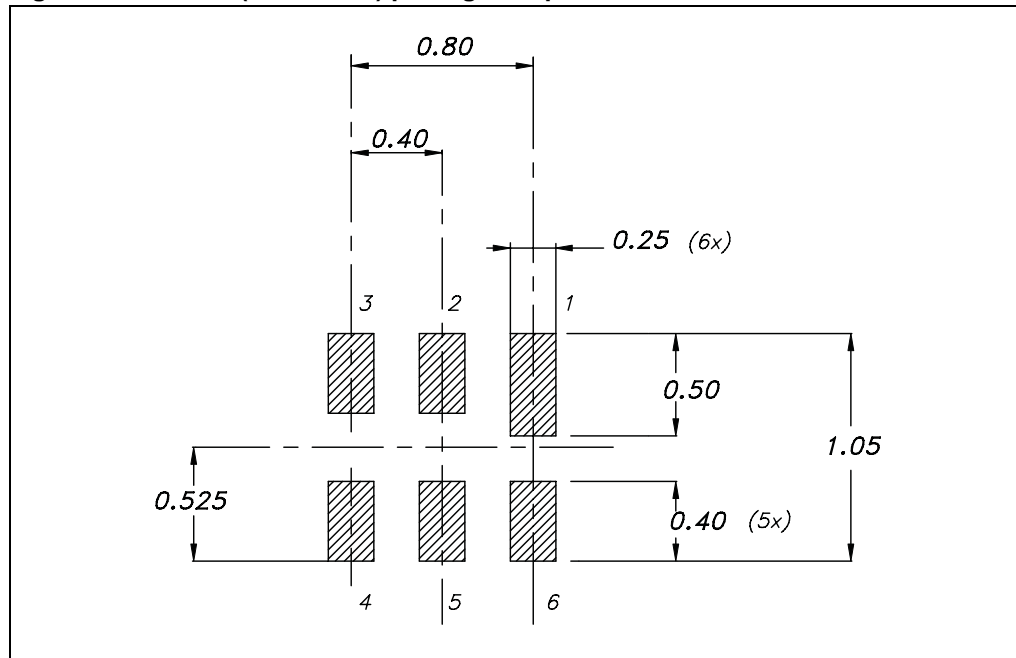

Figure 8. SOT-665 (1.6 x 1.6 mm) package outline

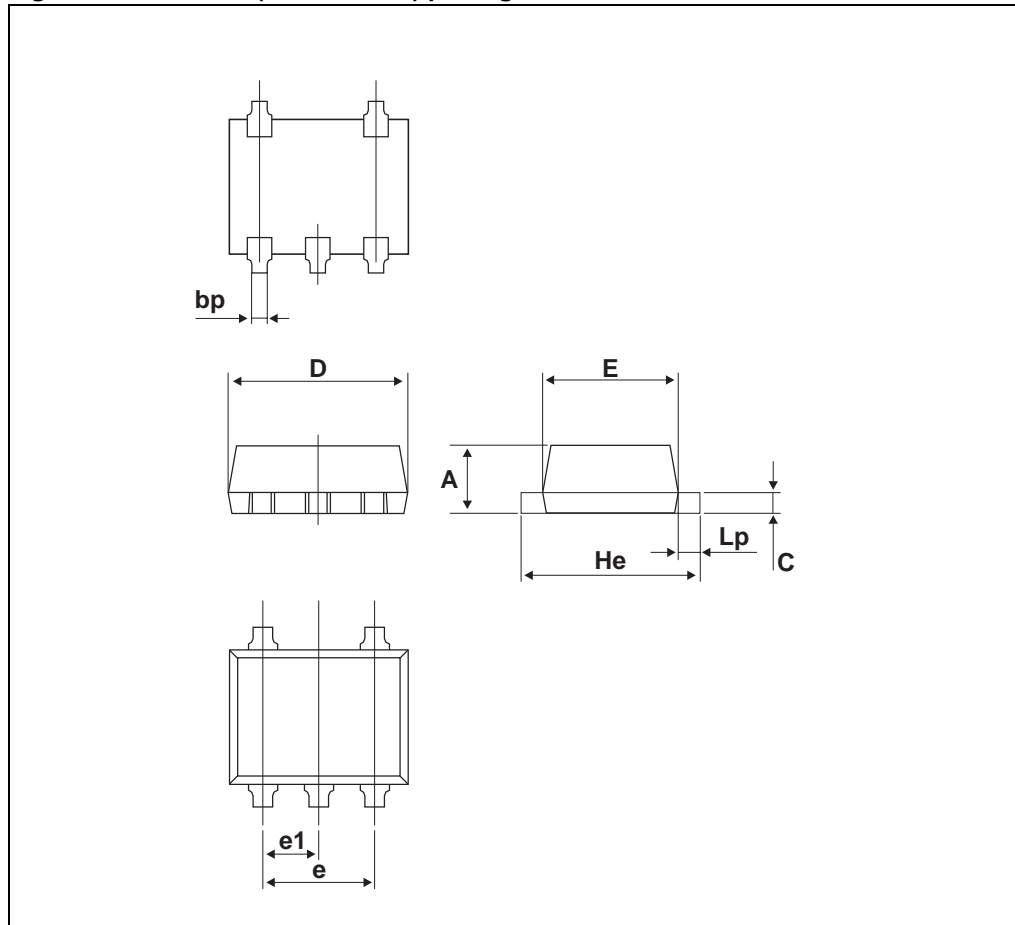

Table 12. SOT665 (1.6 x 1.6 mm) mechanical data

Symbol	Millimeters		
	Typ	Min	Max
A		0.50	0.60
bp		0.17	0.27
c		0.08	0.18
D		1.5	1.7
E		1.1	1.3
e	1		
e1	0.5		
He		1.5	1.7
Lp		0.1	0.3

Figure 9. SOT-665 (1.6 x 1.6 mm) package footprint

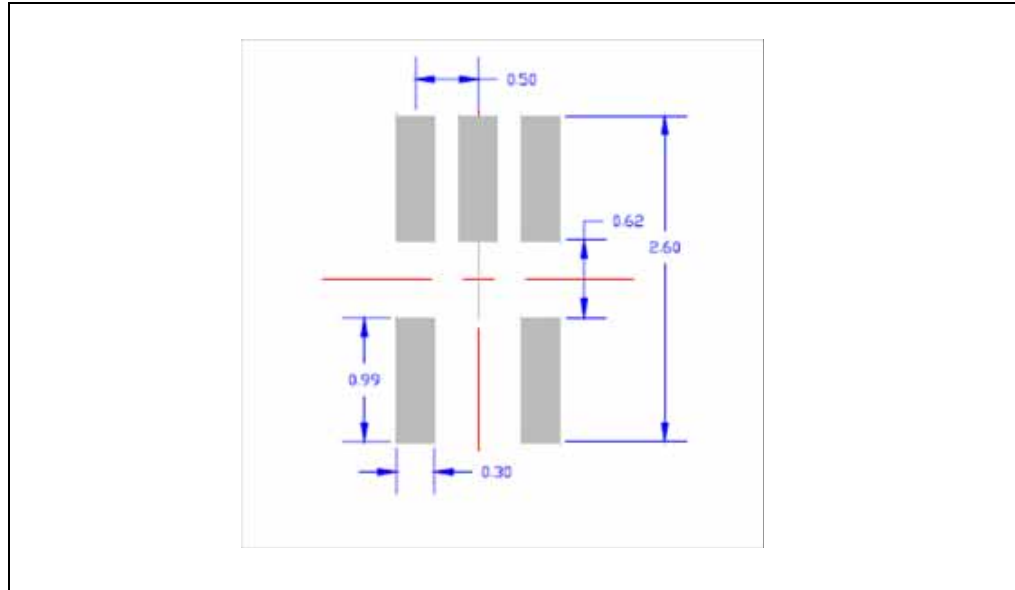

Figure 10. DFN6L (1.2 x 1 mm) carrier tape information

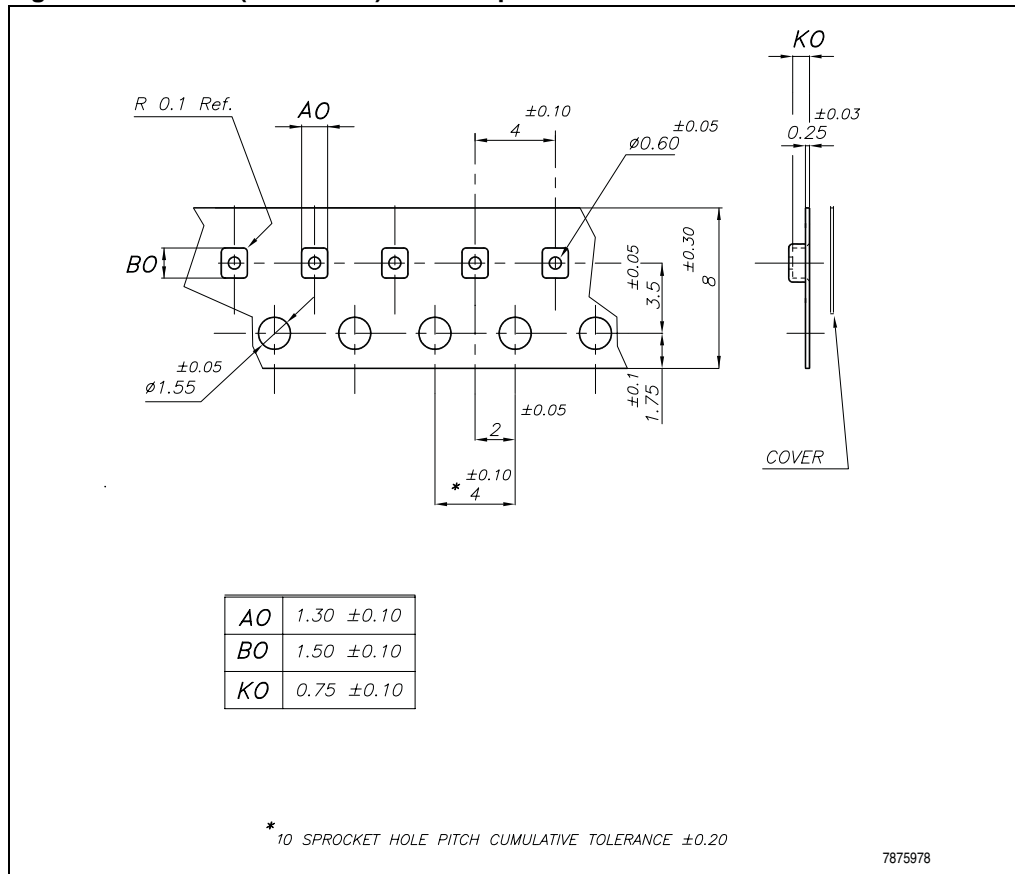

Figure 11. DFN6L (1.2 x 1 mm) reel information drawing (back view)

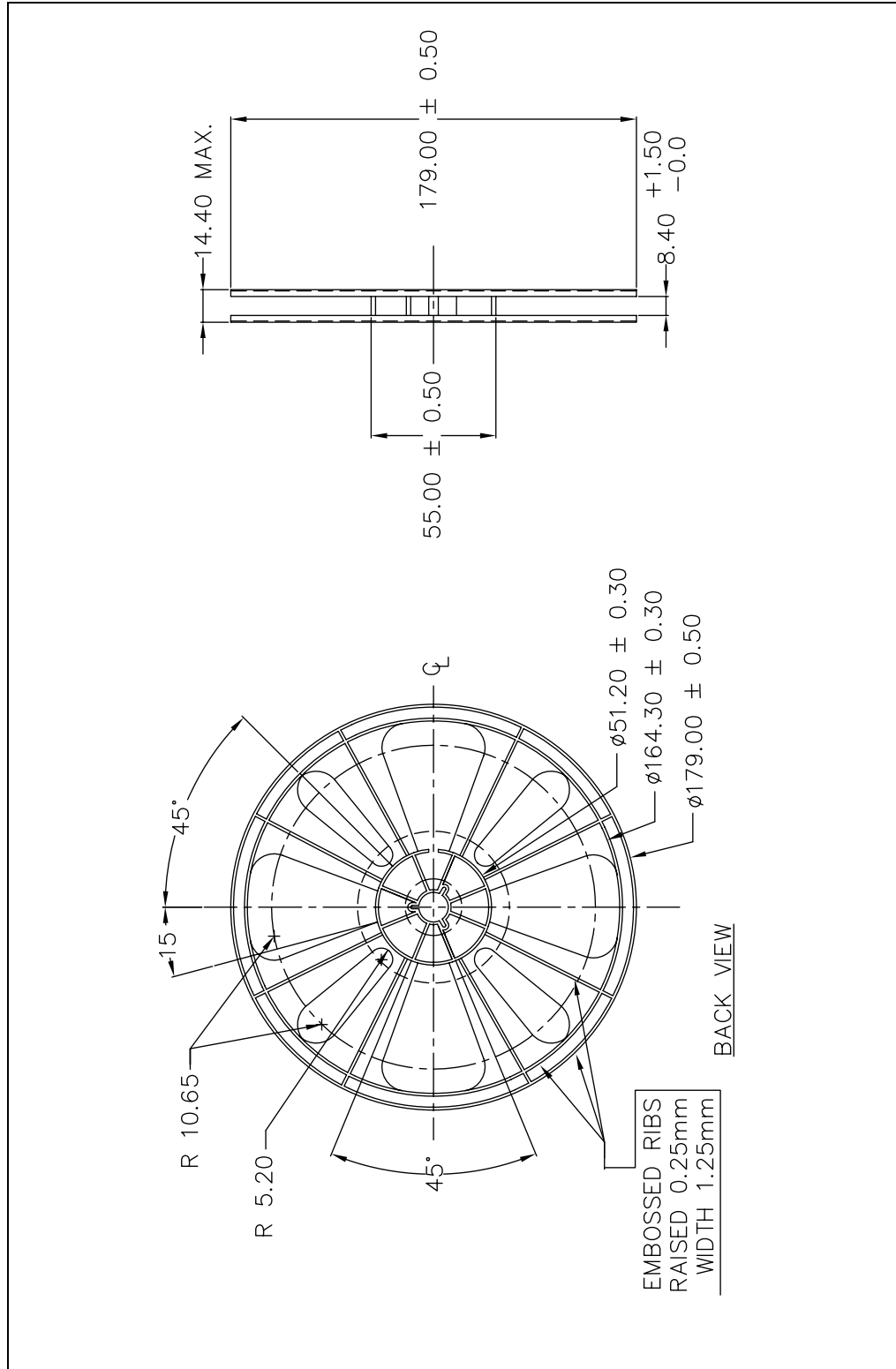

Figure 12. DFN6L (1.2 x 1 mm) reel information drawing (front view)

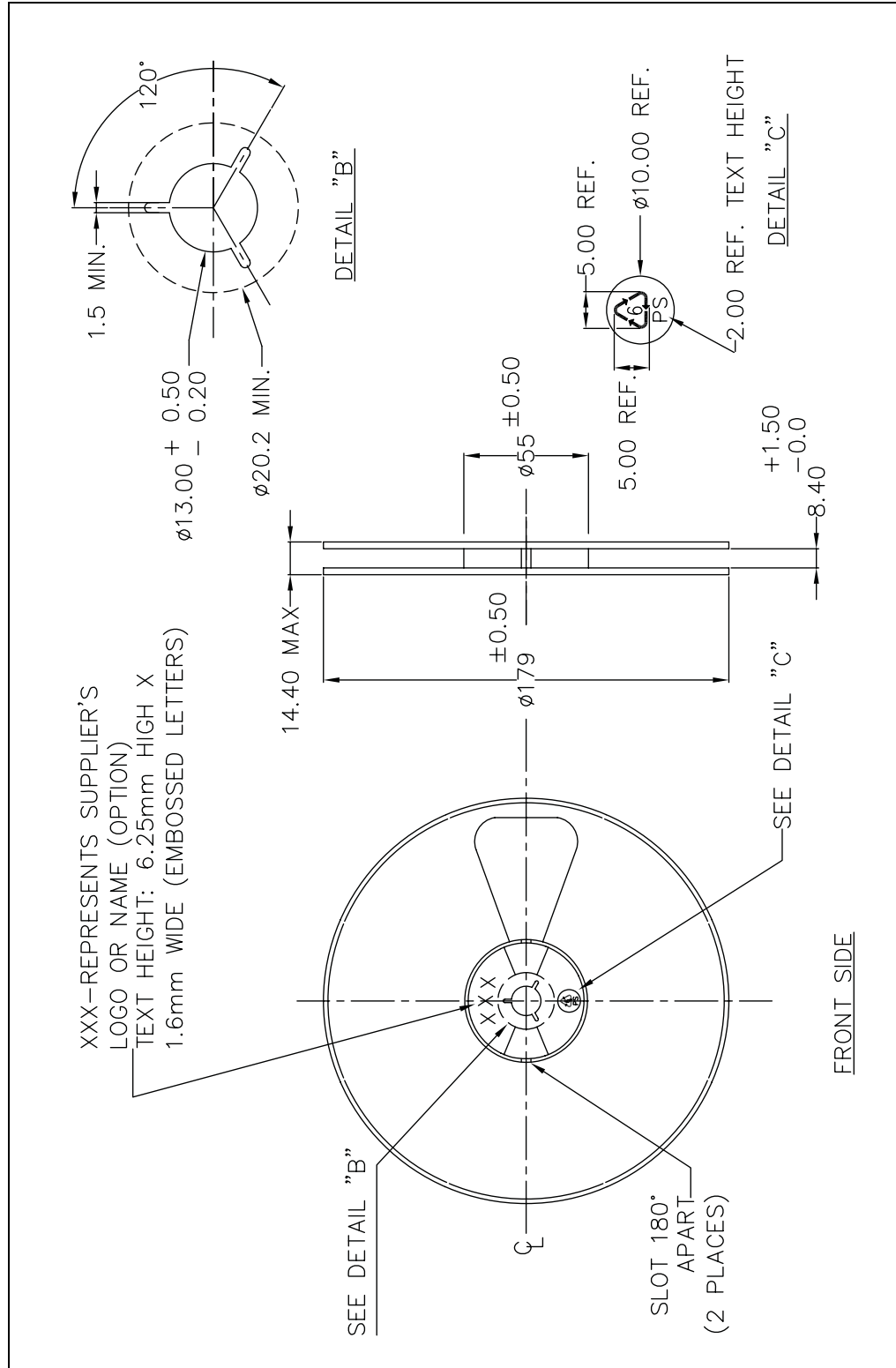

Figure 13. SOT-665 (1.6 x 1.6 mm) carrier tape information

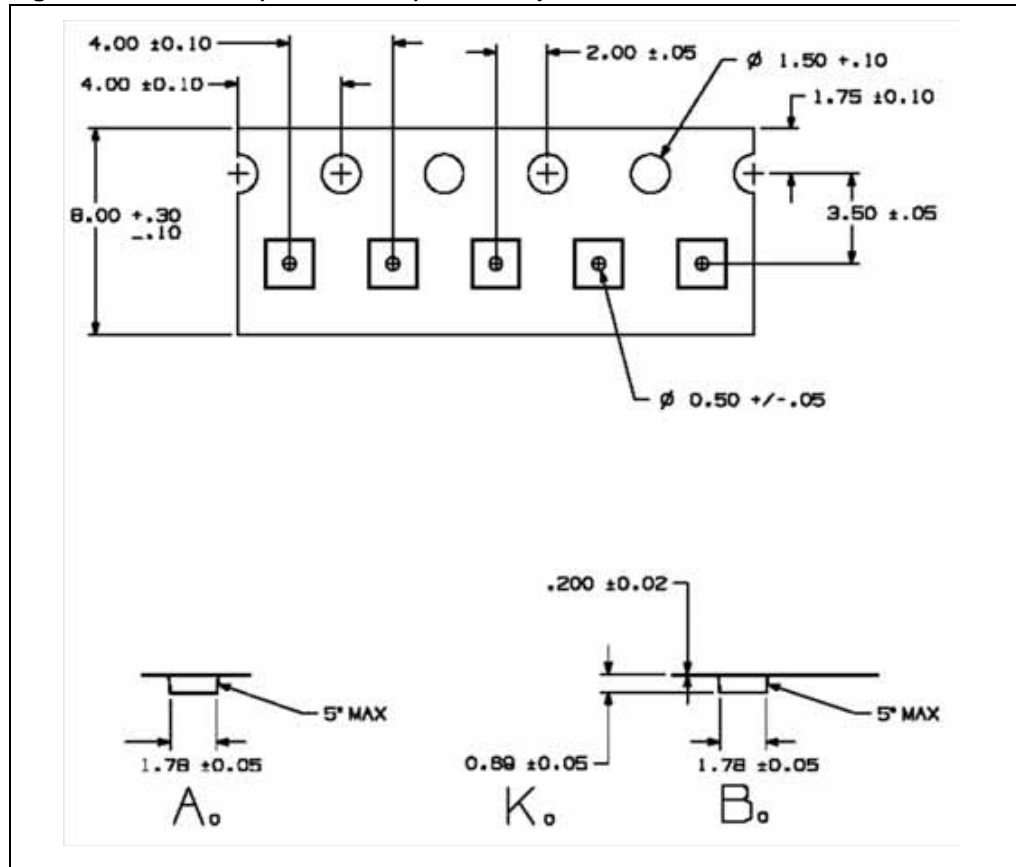

Figure 14. SOT-665 (1.6 x 1.6 mm) reel information

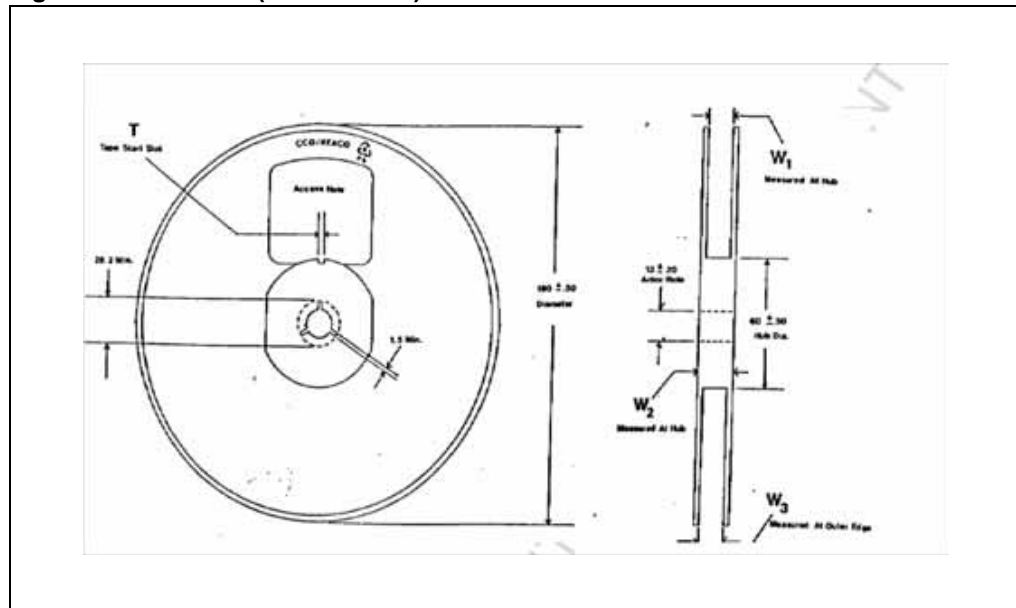

Table 13. SOT-665 (1.6 x 1.6 mm) reel description

Value ⁽¹⁾	R1	R2	R3	eint (at hub)	e1	W1	W2	W3
Min	12.8	175	59.5	8.4	1.5	8.4		7.9
Typ	13	180	60	8.4		8.4		9.4
Max	13.2	185	60.5	10		10	14.4	10.9

1. Millimeters.

6 Revision history

Table 14. Document revision history

Date	Revision	Changes
28-Mar-2008	1	Initial release.

Please Read Carefully:

Information in this document is provided solely in connection with ST products. STMicroelectronics NV and its subsidiaries ("ST") reserve the right to make changes, corrections, modifications or improvements, to this document, and the products and services described herein at any time, without notice.

All ST products are sold pursuant to ST's terms and conditions of sale.

Purchasers are solely responsible for the choice, selection and use of the ST products and services described herein, and ST assumes no liability whatsoever relating to the choice, selection or use of the ST products and services described herein.

No license, express or implied, by estoppel or otherwise, to any intellectual property rights is granted under this document. If any part of this document refers to any third party products or services it shall not be deemed a license grant by ST for the use of such third party products or services, or any intellectual property contained therein or considered as a warranty covering the use in any manner whatsoever of such third party products or services or any intellectual property contained therein.

UNLESS OTHERWISE SET FORTH IN ST'S TERMS AND CONDITIONS OF SALE ST DISCLAIMS ANY EXPRESS OR IMPLIED WARRANTY WITH RESPECT TO THE USE AND/OR SALE OF ST PRODUCTS INCLUDING WITHOUT LIMITATION IMPLIED WARRANTIES OF MERCHANTABILITY, FITNESS FOR A PARTICULAR PURPOSE (AND THEIR EQUIVALENTS UNDER THE LAWS OF ANY JURISDICTION), OR INFRINGEMENT OF ANY PATENT, COPYRIGHT OR OTHER INTELLECTUAL PROPERTY RIGHT.

UNLESS EXPRESSLY APPROVED IN WRITING BY AN AUTHORIZED ST REPRESENTATIVE, ST PRODUCTS ARE NOT RECOMMENDED, AUTHORIZED OR WARRANTED FOR USE IN MILITARY, AIR CRAFT, SPACE, LIFE SAVING, OR LIFE SUSTAINING APPLICATIONS, NOR IN PRODUCTS OR SYSTEMS WHERE FAILURE OR MALFUNCTION MAY RESULT IN PERSONAL INJURY, DEATH, OR SEVERE PROPERTY OR ENVIRONMENTAL DAMAGE. ST PRODUCTS WHICH ARE NOT SPECIFIED AS "AUTOMOTIVE GRADE" MAY ONLY BE USED IN AUTOMOTIVE APPLICATIONS AT USER'S OWN RISK.

Resale of ST products with provisions different from the statements and/or technical features set forth in this document shall immediately void any warranty granted by ST for the ST product or service described herein and shall not create or extend in any manner whatsoever, any liability of ST.

ST and the ST logo are trademarks or registered trademarks of ST in various countries.

Information in this document supersedes and replaces all information previously supplied.

The ST logo is a registered trademark of STMicroelectronics. All other names are the property of their respective owners.

© 2008 STMicroelectronics - All rights reserved

STMicroelectronics group of companies

Australia - Belgium - Brazil - Canada - China - Czech Republic - Finland - France - Germany - Hong Kong - India - Israel - Italy - Japan - Malaysia - Malta - Morocco - Singapore - Spain - Sweden - Switzerland - United Kingdom - United States of America

www.st.com