

AN5272

4.0 W × 2 (18 V, 8 Ω) Power Amplifier with Variable Audio Output and Volume Control

■ Overview

The AN5272 is a monolithic integrated circuit designed for 4.0 W (18 V, 8 Ω) output audio power amplifier. It is a dual channel SEPP IC suitable for stereo operation in TV application.

■ Features

- Built-in DC volume control
- Built-in thermal protection circuit
- Built-in over current protection circuit
- 2 Variable Audio Output (VAO)
- V_{CC} operating range : 12.2 V to 27.5 V

■ Applications

- TV

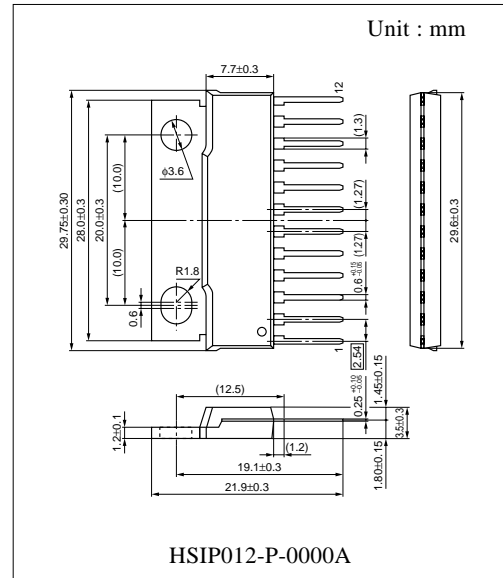

■ Block Diagram

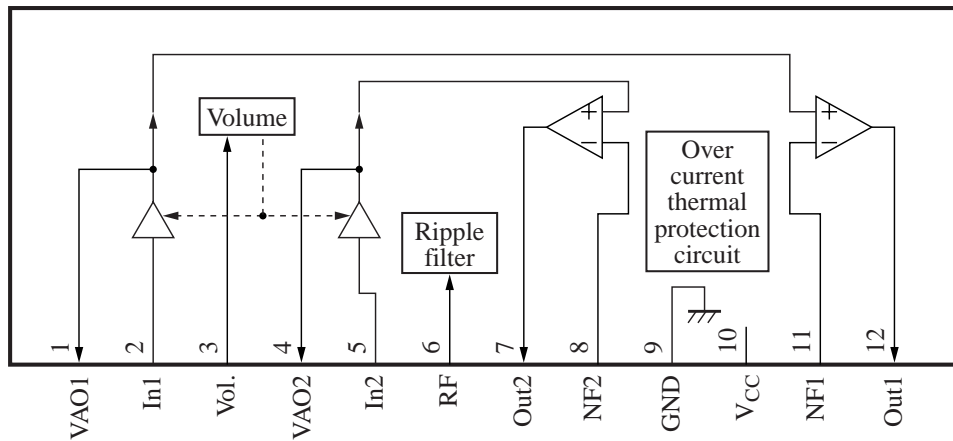

■ Pin Descriptions

Pin No.	Description	Pin No.	Description
1	Variable audio output 1	7	Ch.2 output
2	Ch.1 input	8	Negative feedback ch.2
3	Volume control	9	GND
4	Variable audio output 2	10	V _{CC}
5	Ch.2 input	11	Negative feedback ch.1
6	Ripple filter	12	Ch.1 output

■ Absolute Maximum Ratings

Parameter	Symbol	Rating	Unit
Supply voltage	V _{CC}	30	V
Supply current	I _{CC}	3.5	A
Power dissipation *2	P _D	37.5	W
Operating ambient temperature *1	T _{opr}	-25 to +75	°C
Storage temperature *1	T _{stg}	-55 to +150	°C

Note) *1 : T_a = 25 °C except power dissipation, operating ambient temperature and storage temperature.

*2 : Power dissipation of the package at T_a = 75 °C.

■ Recommended Operating Range

Parameter	Symbol	Range	Unit
Supply voltage	V _{CC}	12.2 to 27.5	V

■ Electrical Characteristics at V_{CC} = 18 V, f = 1 kHz, R_L = 8 Ω, T_a = 25 °C

Parameter	Symbol	Conditions	Min	Typ	Max	Unit
Quiescent current	I _{CQ}	No input signal	17	25	33	mA
Voltage gain	G _V	V _{IN} = 90 mV	28	30	32	dB
Total harmonic distortion *1	THD	V _{IN} = 90 mV		0.3	1.0	%
Output power *1	P _O	THD = 10 %	3.6	4.1		W
Channel balance	CB	V _{IN} = 90 mV	-1	0	1	dB
Max. volume attenuation *1	Att	V _{IN} = 90 mV		-70	-64	dB
VAO voltage gain	G _{VAO}	V _{IN} = 90 mV	10	12	14	dB
Output noise voltage *1	V _{NO}	R _g = 10 kΩ, Din-Audio Filter		0.6	1.0	mV[rms]

Note) *1 : With a filter band from 20 Hz to 20 kHz used.

■ Application Circuit Example

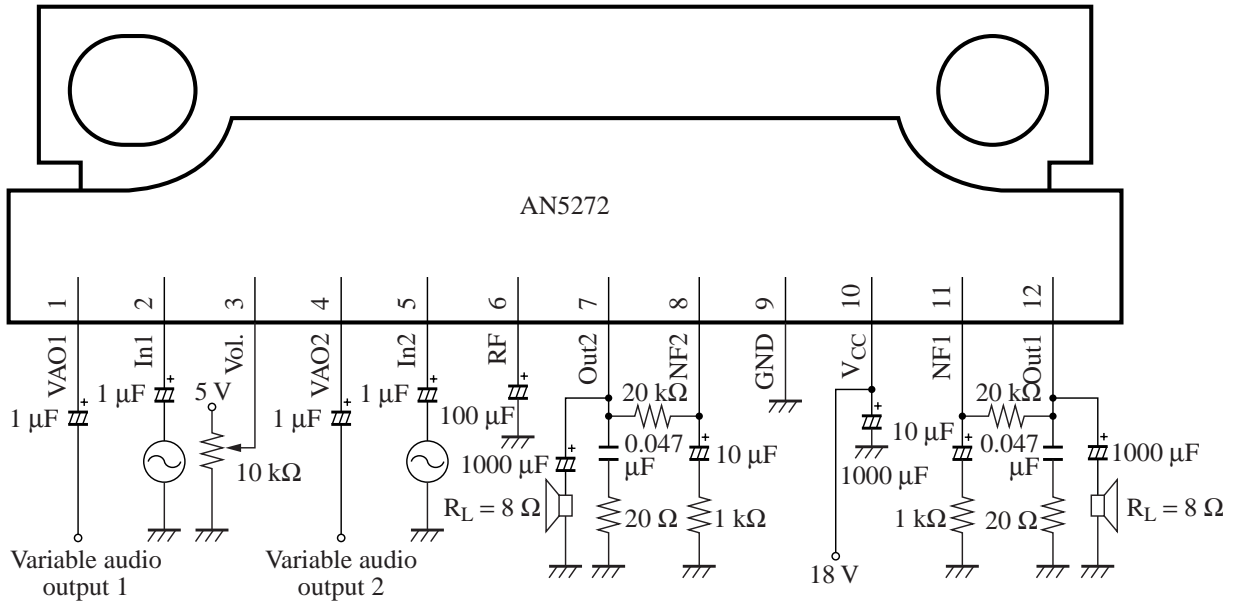

■ Usage Notes

- 1) Depending on the maximum application output power, external heatsink may be needed.
External heatsink should be fixed to the chassis.
- 2) Fin of the IC can be connected to GND.
- 3) Please prevent output to V_{CC} short and output to GND short.
- 4) The temperature protection circuit will operate at T_j around 150 °C. However, if the temperature decreases, the protection circuit would automatically be deactivated and resume normal operation.

■ Technical Information

1.Characteristic Curve Chart

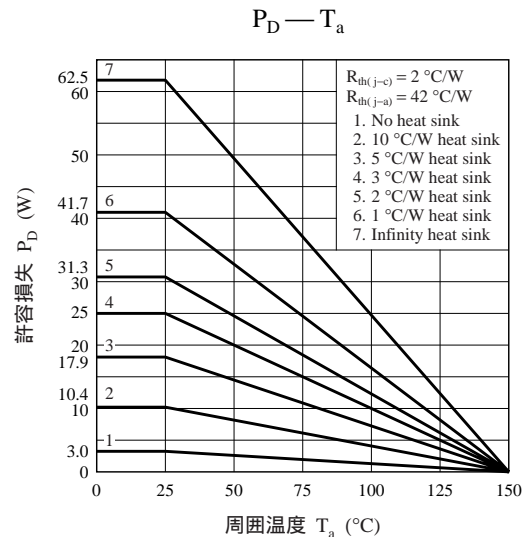
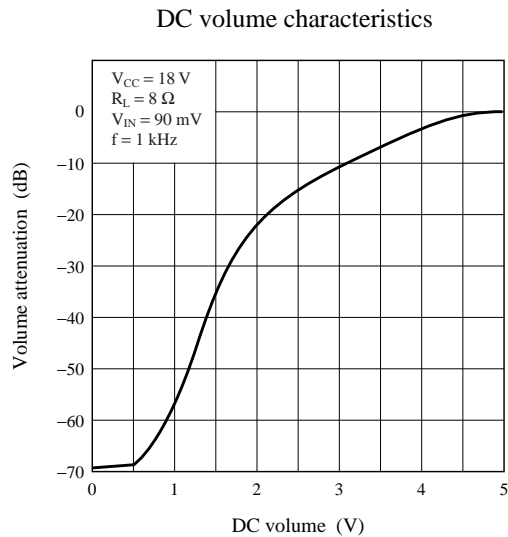
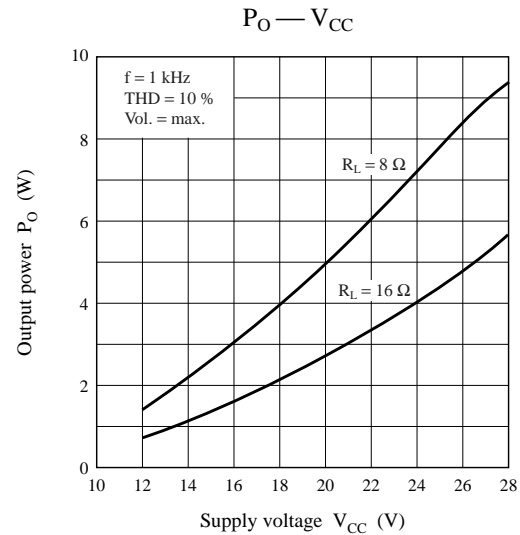
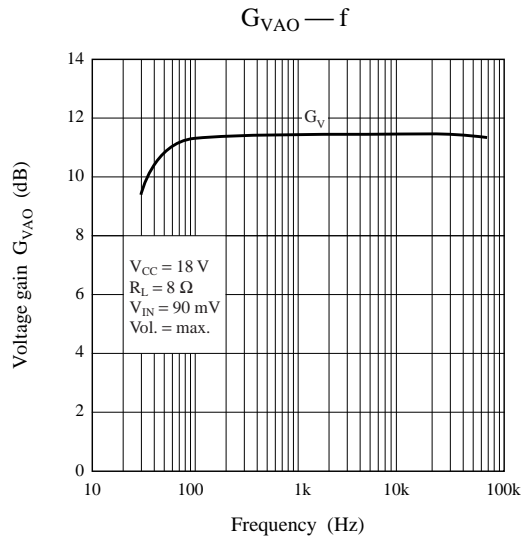
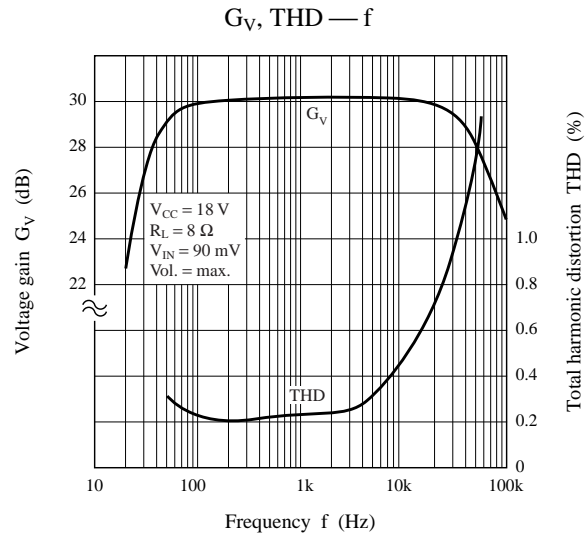
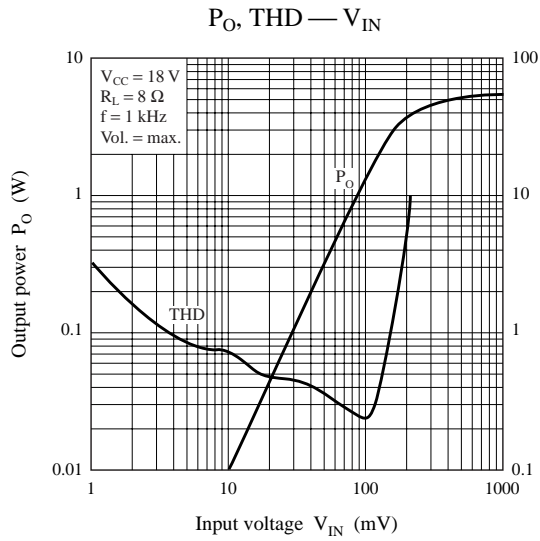

■ Technical Information (continued)

2. Application Note

1) Voltage gain

The voltage gain of the AN5272 can be varied by changing the resistor R2 as shown below :

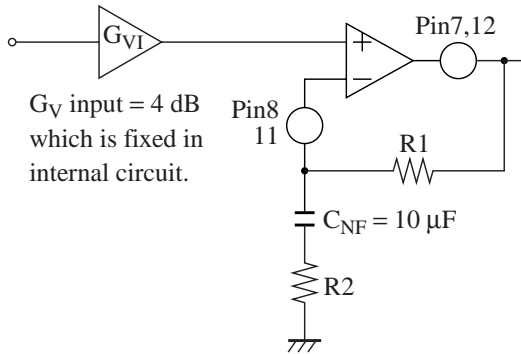

G_V input = 4 dB
which is fixed in
internal circuit.

R1 is always fixed at 20 k Ω .

R2 is variable.

$$G_{VO} = 20 \log (R_1/R_2)$$

Typical values are : R₁ = 20 k Ω , R₂ = 1 k Ω

$$G_{VO} = 20 \log (20 \text{ k}/1 \text{ k}) \\ = 26 \text{ dB}$$

$$G_{VTOTAL} = G_{VI} + G_{VO} \\ = 4 \text{ dB} + 26 \text{ dB} \\ = 30 \text{ dB}$$

2) DC volume control

The DC volume control range is 0 V to 5 V. This range is used in order to be easily controlled by micro-computer using PWM output. The recommended circuit and volume attenuation characteristic are shown below :

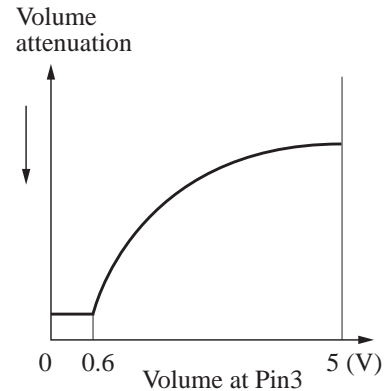
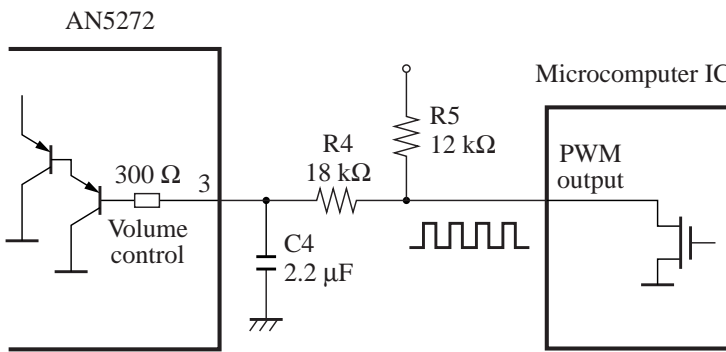
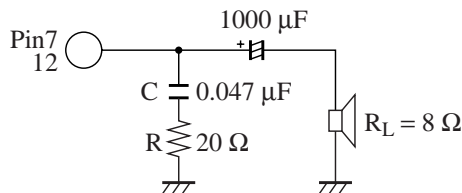

Fig. Volume control interface circuit for AN5272

Fig. Volume characteristic of AN5272

3) Oscillation

To prevent oscillation, it is advisable to use RC (Zobel network) at output. C of polyester film capacitor has smaller characteristic fluctuation with temperature and frequency. The resistor R connected in series with C is effective for phase correction at high frequency, and as a result, it improves the oscillation allowance.



■ Technical Information (continued)

2. Application Note (continued)

4) Power-ON/OFF pop-noise elimination

The output pins 7, 12 and V_O , during power turn ON and OFF are shown below :

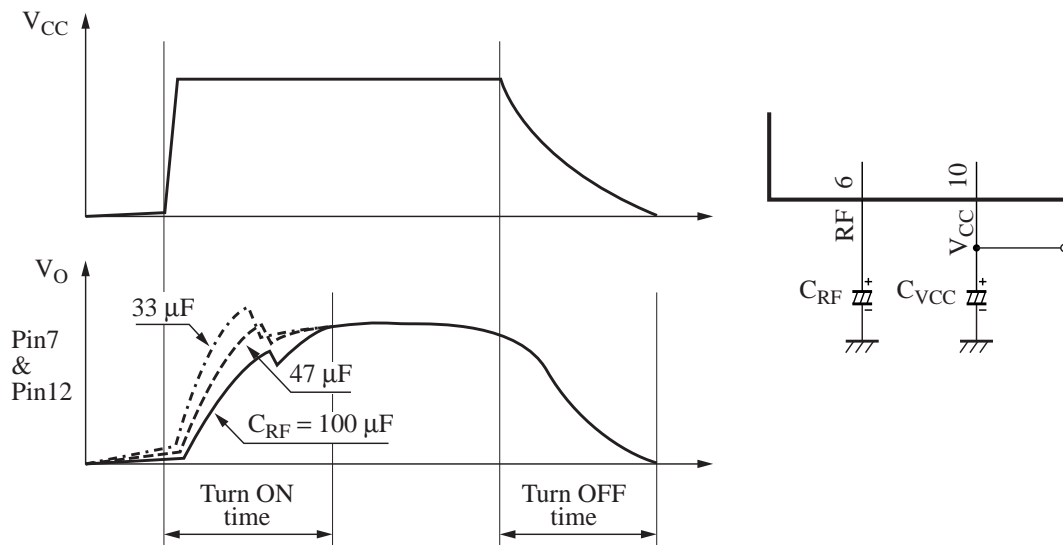

The turn ON time in the AN5272 is determined by the capacitance value of C_{RF} . If value of the C_{RF} is smaller, V_O would turn ON faster.

The turn OFF time is dependent on the capacitance value of C_{VCC} . Pop-noise would occur when V_{CC} voltage declines faster than RF voltage. To solve this, increase the discharge time of V_{CC} by increasing the capacitance values of C_{VCC} .

The recommended values of capacitance for C_{VCC} and C_{RF} are shown below :

No.	C_{RF}	C_{VCC}	Recommended Operating V_{CC} Range	Unit
1	33 μ F	470 μ F	14.5 to 27.5	V
2	47 μ F	470 μ F	12.2 to 27.5	V
3	100 μ F	1000 μ F	12.2 to 27.5	V

5) Stand-by circuit

Stand-by function can be implemented in the AN5272 by external solution. It is realised by pulling the RF voltage to low and output voltage would follow RF as shown in the diagram.

