

HEX D-TYPE FLIP FLOP WITH CLEAR

- HIGH SPEED:
 $f_{MAX} = 175\text{MHz}$ (TYP.) at $V_{CC} = 5\text{V}$
- LOW POWER DISSIPATION:
 $I_{CC} = 4\ \mu\text{A}$ (MAX.) at $T_A = 25^\circ\text{C}$
- HIGH NOISE IMMUNITY:
 $V_{NIH} = V_{NIL} = 28\% V_{CC}$ (MIN.)
- POWER DOWN PROTECTION ON INPUTS
- SYMMETRICAL OUTPUT IMPEDANCE:
 $|I_{OH}| = I_{OL} = 8\ \text{mA}$ (MIN)
- BALANCED PROPAGATION DELAYS:
 $t_{PLH} \cong t_{PHL}$
- OPERATING VOLTAGE RANGE:
 $V_{CC}(\text{OPR}) = 2\text{V to } 5.5\text{V}$
- PIN AND FUNCTION COMPATIBLE WITH
 74 SERIES 174
- IMPROVED LATCH-UP IMMUNITY
- LOW NOISE: $V_{OLP} = 0.8\text{V}$ (MAX.)

DESCRIPTION

The 74VHC174 is an advanced high-speed CMOS HEX D-TYPE FLIP FLOP WITH CLEAR fabricated with sub-micron silicon gate and double-layer metal wiring C²MOS technology. Information signals applied to D inputs are transferred to the Q outputs on the positive going edge of the clock pulse.

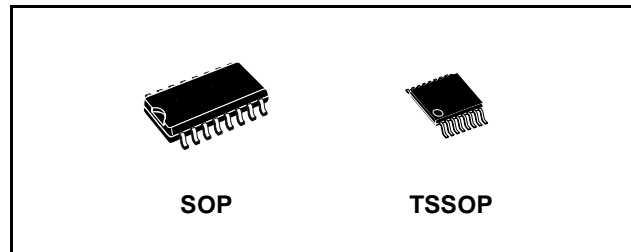

Table 1: Order Codes

PACKAGE	T & R
SOP	74VHC174MTR
TSSOP	74VHC174TTR

When the $\overline{\text{CLEAR}}$ input is held low, the Q outputs are held low independently of the other inputs. Power down protection is provided on all inputs and 0 to 7V can be accepted on inputs with no regard to the supply voltage. This device can be used to interface 5V to 3V.

All inputs and outputs are equipped with protection circuits against static discharge, giving them 2KV ESD immunity and transient excess voltage.

Figure 1: Pin Connection And IEC Logic Symbols

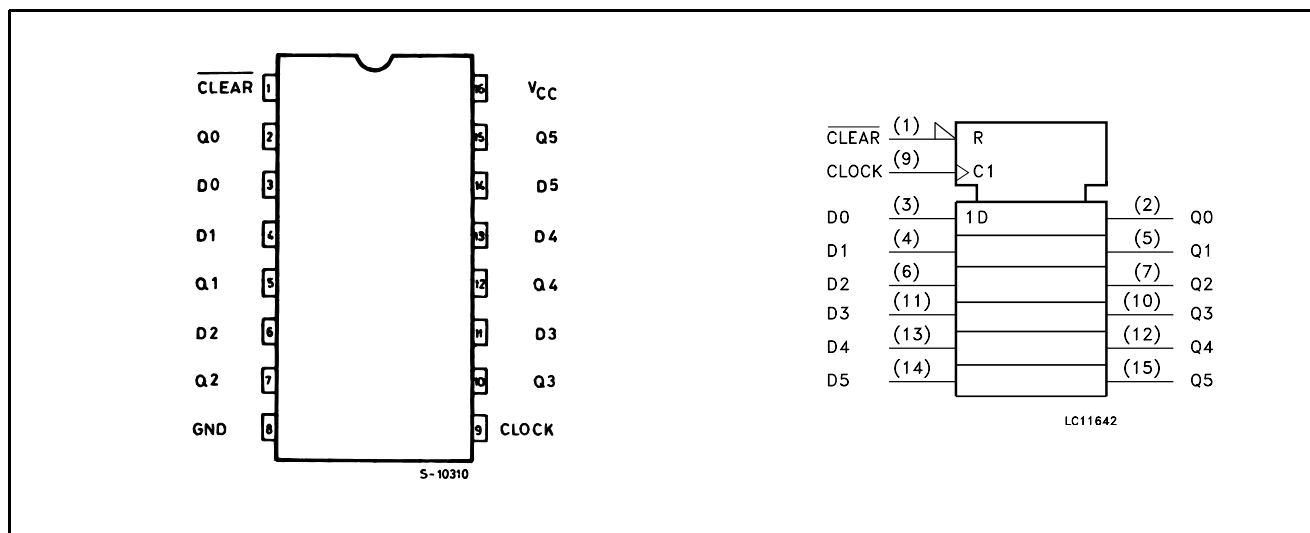

Figure 2: Input Equivalent Circuit

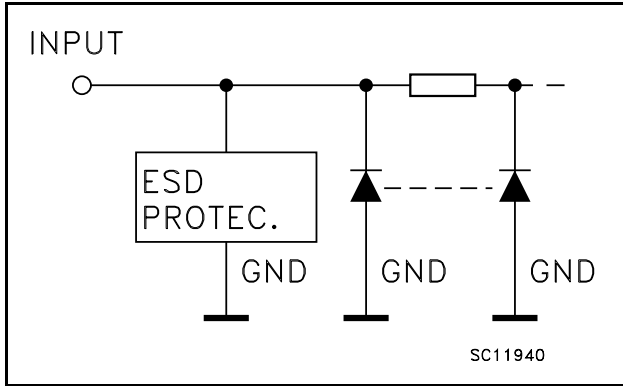

Table 2: Pin Description

PIN N°	SYMBOL	NAME AND FUNCTION
1	CLEAR	Asynchronous Master Reset (Active LOW)
2, 5, 7, 10, 12, 15	Q0 to Q5	Flip-Flop Outputs
3, 4, 6, 11, 13, 14	D0 to D5	Data Inputs
9	CLOCK	Clock Input (LOW-to-HIGH, Edge Triggered)
8	GND	Ground (0V)
16	V _{CC}	Positive Supply Voltage

Table 3: Truth Table

INPUTS			OUTPUTS	FUNCTION
CLEAR	D	CLOCK	Q	
L	X	X	L	CLEAR
H	L		L	
H	H		H	
H	X		Q _n	NO CHANGE

X : Don't Care

Figure 3: Logic Diagram

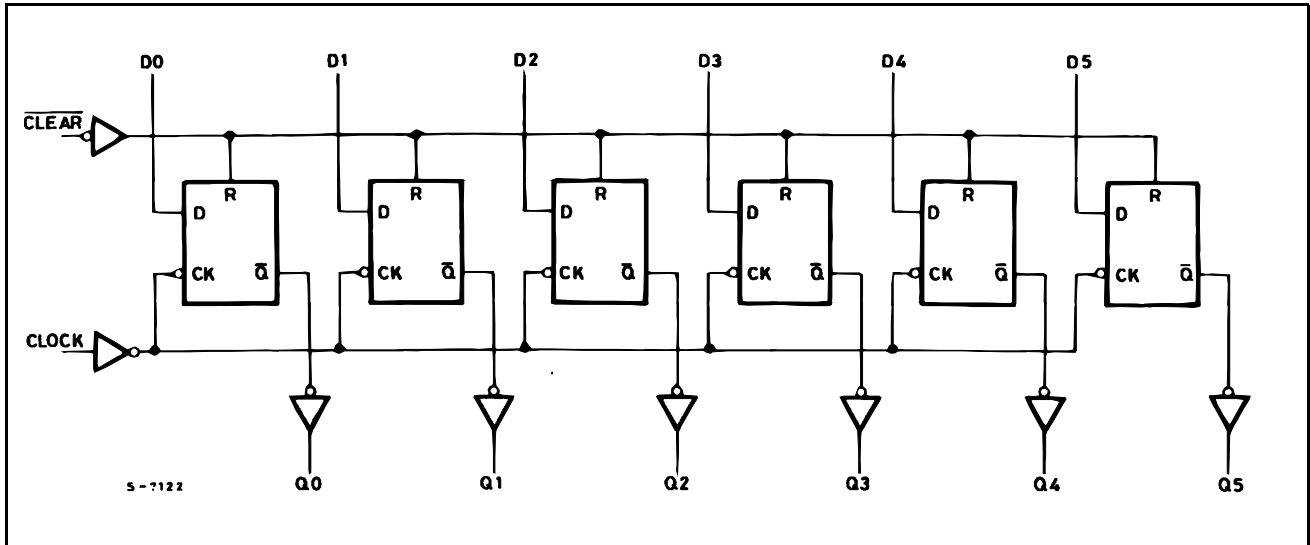

This logic diagram has not to be used to estimate propagation delays

Table 4: Absolute Maximum Ratings

Symbol	Parameter	Value	Unit
V_{CC}	Supply Voltage	-0.5 to +7.0	V
V_I	DC Input Voltage	-0.5 to +7.0	V
V_O	DC Output Voltage	-0.5 to $V_{CC} + 0.5$	V
I_{IK}	DC Input Diode Current	- 20	mA
I_{OK}	DC Output Diode Current	± 20	mA
I_O	DC Output Current	± 25	mA
I_{CC} or I_{GND}	DC V_{CC} or Ground Current	± 50	mA
T_{stg}	Storage Temperature	-65 to +150	°C
T_L	Lead Temperature (10 sec)	300	°C

Absolute Maximum Ratings are those values beyond which damage to the device may occur. Functional operation under these conditions is not implied

Table 5: Recommended Operating Conditions

Symbol	Parameter	Value	Unit
V_{CC}	Supply Voltage	2 to 5.5	V
V_I	Input Voltage	0 to 5.5	V
V_O	Output Voltage	0 to V_{CC}	V
T_{op}	Operating Temperature	-55 to 125	°C
dt/dv	Input Rise and Fall Time (note 1) ($V_{CC} = 3.3 \pm 0.3V$) ($V_{CC} = 5.0 \pm 0.5V$)	0 to 100 0 to 20	ns/V

1) V_{IN} from 30% to 70% of V_{CC}

Table 6: DC Specifications

Symbol	Parameter	Test Condition		Value						Unit	
		V _{CC} (V)		T _A = 25°C			-40 to 85°C		-55 to 125°C		
				Min.	Typ.	Max.	Min.	Max.	Min.		Max.
V _{IH}	High Level Input Voltage	2.0		1.5			1.5		1.5		V
		3.0 to 5.5		0.7V _{CC}			0.7V _{CC}		0.7V _{CC}		
V _{IL}	Low Level Input Voltage	2.0				0.5		0.5		0.5	V
		3.0 to 5.5				0.3V _{CC}		0.3V _{CC}		0.3V _{CC}	
V _{OH}	High Level Output Voltage	2.0	I _O =-50 μA	1.9	2.0		1.9		1.9		V
		3.0	I _O =-50 μA	2.9	3.0		2.9		2.9		
		4.5	I _O =-50 μA	4.4	4.5		4.4		4.4		
		3.0	I _O =-4 mA	2.58			2.48		2.4		
		4.5	I _O =-8 mA	3.94			3.8		3.7		
V _{OL}	Low Level Output Voltage	2.0	I _O =50 μA		0.0	0.1		0.1		0.1	V
		3.0	I _O =50 μA		0.0	0.1		0.1		0.1	
		4.5	I _O =50 μA		0.0	0.1		0.1		0.1	
		3.0	I _O =4 mA			0.36		0.44		0.55	
		4.5	I _O =8 mA			0.36		0.44		0.55	
I _I	Input Leakage Current	0 to 5.5	V _I = 5.5V or GND			± 0.1		± 1		± 1	μA
I _{CC}	Quiescent Supply Current	5.5	V _I = V _{CC} or GND			4		40		40	μA

Table 7: AC Electrical Characteristics (Input $t_r = t_f = 3\text{ns}$)

Symbol	Parameter	Test Condition		Value								Unit
		V_{CC} (V)	C_L (pF)	$T_A = 25^\circ\text{C}$			-40 to 85°C		-55 to 125°C			
				Min.	Typ.	Max.	Min.	Max.	Min.	Max.		
t_{PLH} t_{PHL}	Propagation Delay Time CLOCK to Q	3.3 ^(*)	15		5.8	11.0	1.0	13.0	1.0	13.0	ns	
		3.3 ^(*)	50		7.5	14.5	1.0	16.5	1.0	16.5		
		5.0 ^(**)	15		4.1	7.2	1.0	8.5	1.0	8.5		
		5.0 ^(**)	50		5.5	9.2	1.0	10.5	1.0	10.5		
t_{PHL}	Propagation Delay Time CLEAR to Q	3.3 ^(*)	15		7.4	11.4	1.0	13.5	1.0	13.5	ns	
		3.3 ^(*)	50		9.9	14.9	1.0	17.0	1.0	17.0		
		5.0 ^(**)	15		5.1	7.6	1.0	9.0	1.0	9.0		
		5.0 ^(**)	50		6.6	9.6	1.0	11.0	1.0	11.0		
t_W	CLEAR Pulse Width LOW	3.3 ^(*)				5.0		5.0		5.0	ns	
		5.0 ^(**)				5.0		5.0		5.0		
t_W	CLEAR Pulse Width HIGH or LOW	3.3 ^(*)				5.0		5.0		5.0	ns	
		5.0 ^(**)				5.0		5.0		5.0		
t_s	Setup Time D to CLOCK, HIGH or LOW	3.3 ^(*)				5.0		6.0		6.0	ns	
		5.0 ^(**)				4.5		4.5		4.5		
t_h	Hold Time D to CLOCK, HIGH or LOW	3.3 ^(*)				0.0		0.0		0.0	ns	
		5.0 ^(**)				0.5		0.5		0.5		
t_{REM}	Recovery Time CLEAR to CLOCK	3.3 ^(*)				3.0		3.0		3.0	ns	
		5.0 ^(**)				2.5		2.5		2.5		
f_{MAX}	Maximum Clock Frequency	3.3 ^(*)	15		95	150		80		80	MHz	
		3.3 ^(*)	50		55	85		50		50		
		5.0 ^(**)	15		130	175		110		110		
		5.0 ^(**)	50		90	120		80		80		

(*) Voltage range is $3.3\text{V} \pm 0.3\text{V}$ (**) Voltage range is $5.0\text{V} \pm 0.5\text{V}$

Table 8: Capacitive Characteristics

Symbol	Parameter	Test Condition		Value						Unit	
				$T_A = 25^\circ\text{C}$			-40 to 85°C		-55 to 125°C		
				Min.	Typ.	Max.	Min.	Max.	Min.		Max.
C_{IN}	Input Capacitance				6	10		10		10	pF
C_{PD}	Power Dissipation Capacitance (note 1)				15						pF

1) C_{PD} is defined as the value of the IC's internal equivalent capacitance which is calculated from the operating current consumption without load. (Refer to Test Circuit). Average operating current can be obtained by the following equation. $I_{CC(opr)} = C_{PD} \times V_{CC} \times f_{IN} + I_{CC}/6$ (per Flip-Flop)

Table 9: Dynamic Switching Characteristics

Symbol	Parameter	Test Condition		Value						Unit	
		V _{CC} (V)		T _A = 25°C			-40 to 85°C		-55 to 125°C		
				Min.	Typ.	Max.	Min.	Max.	Min.		Max.
V _{OLP}	Dynamic Low Voltage Quiet Output (note 1, 2)	5.0	C _L = 50 pF		0.3	0.8					V
V _{OLV}				-0.8	-0.3						
V _{IHD}	Dynamic High Voltage Input (note 1, 3)	5.0		3.5							V
V _{ILD}	Dynamic Low Voltage Input (note 1, 3)	5.0				1.5					V

- 1) Worst case package.
- 2) Max number of outputs defined as (n). Data inputs are driven 0V to 5.0V, (n-1) outputs switching and one output at GND.
- 3) Max number of data inputs (n) switching. (n-1) switching 0V to 5.0V. Inputs under test switching: 5.0V to threshold (V_{ILD}), 0V to threshold (V_{IHD}), f=1MHz.

Figure 4: Test Circuit

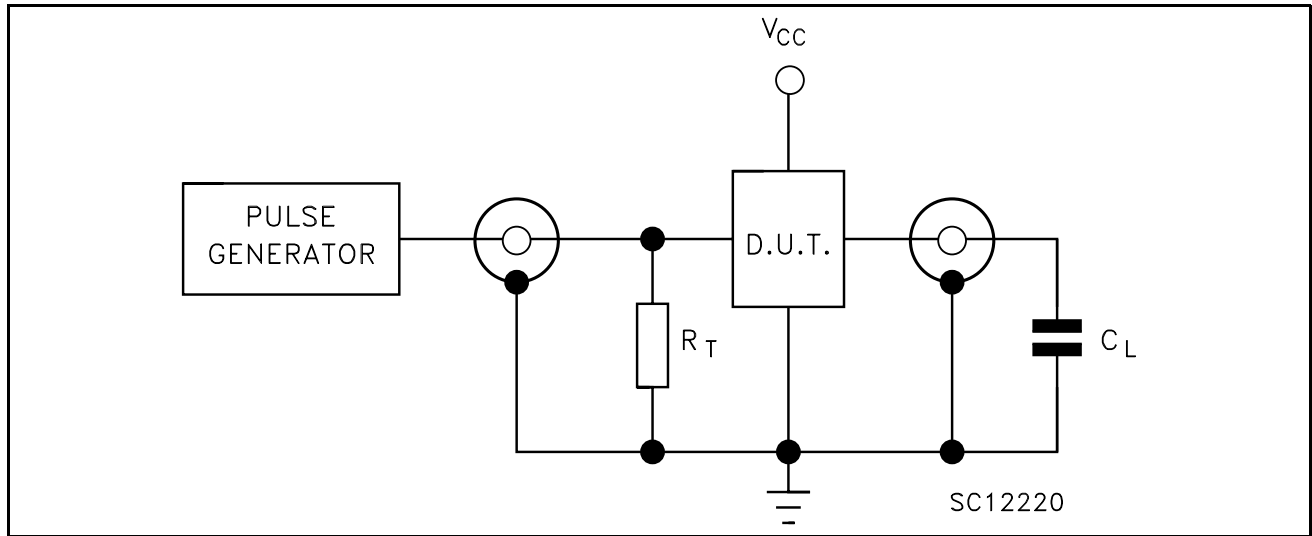

C_L = 15/50pF or equivalent (includes jig and probe capacitance)
 R_T = Z_{OUT} of pulse generator (typically 50Ω)

Figure 5: Waveform - Propagation Delays, Setup And Hold Times (f=1MHz; 50% duty cycle)

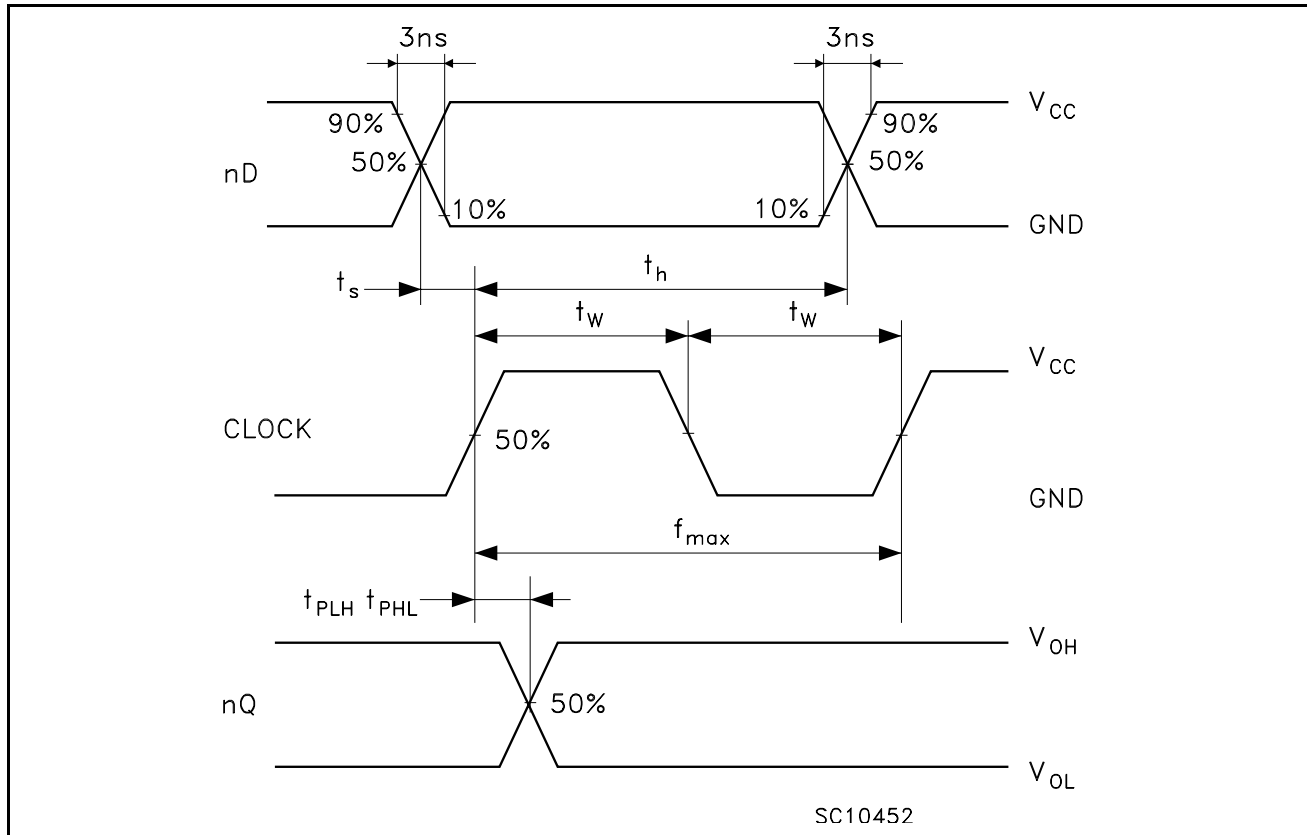

Figure 6: Waveform - Propagation Delays (f=1MHz; 50% duty cycle)

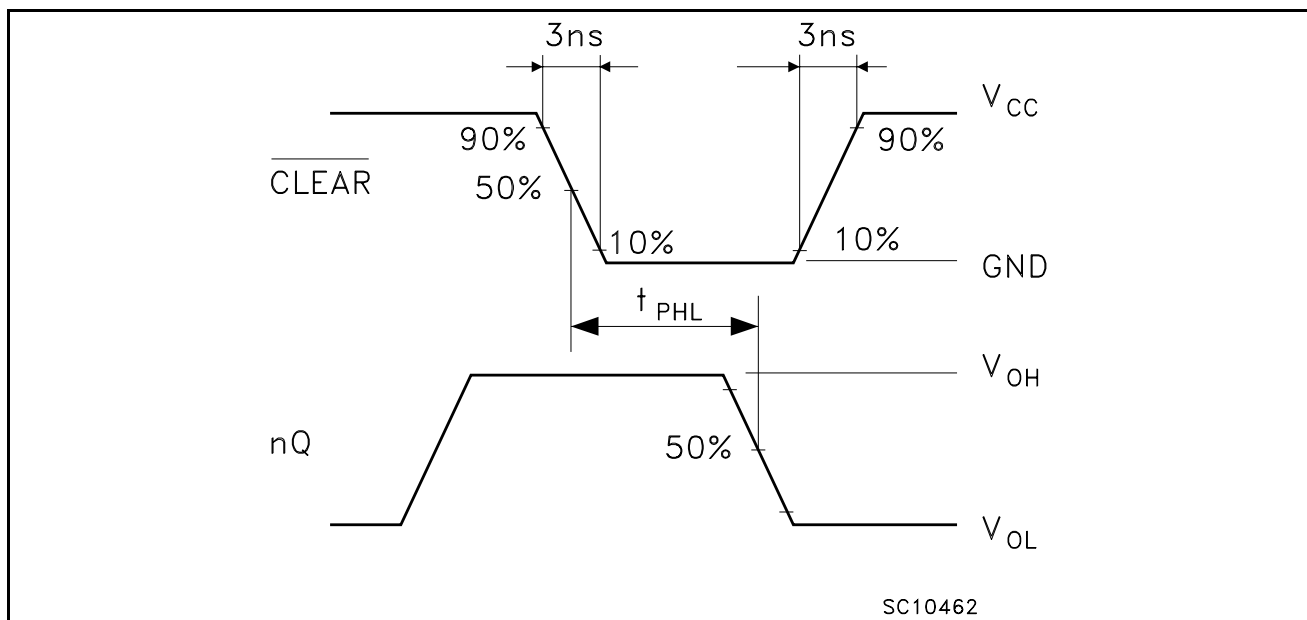
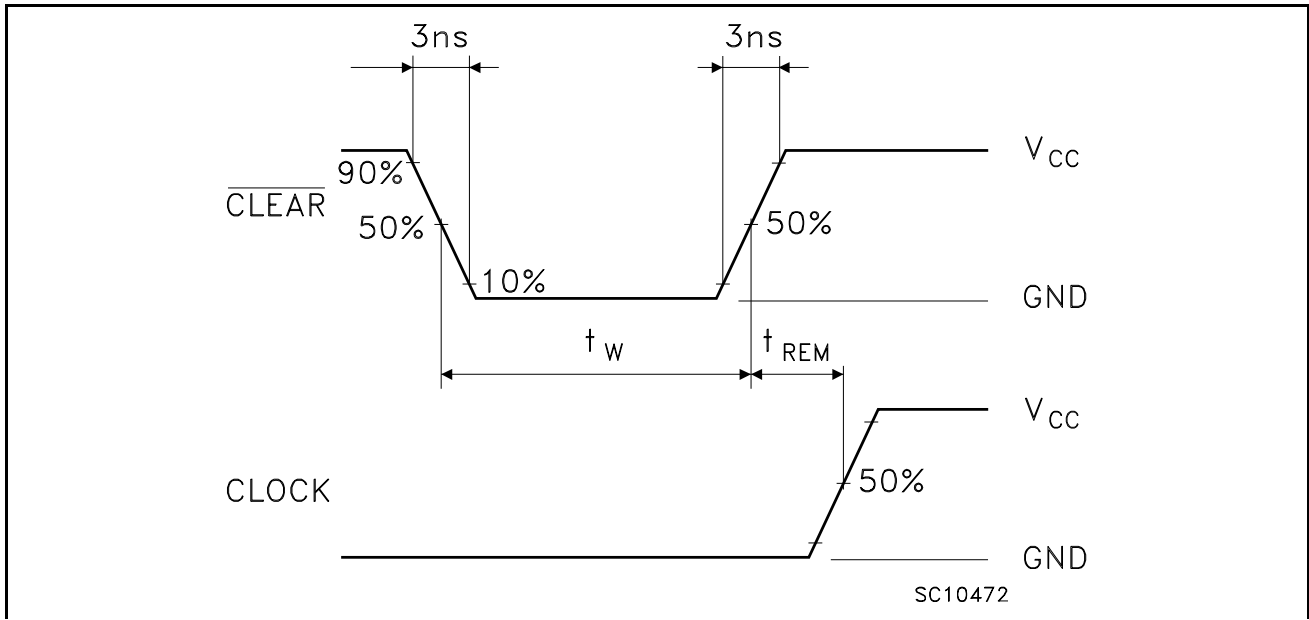
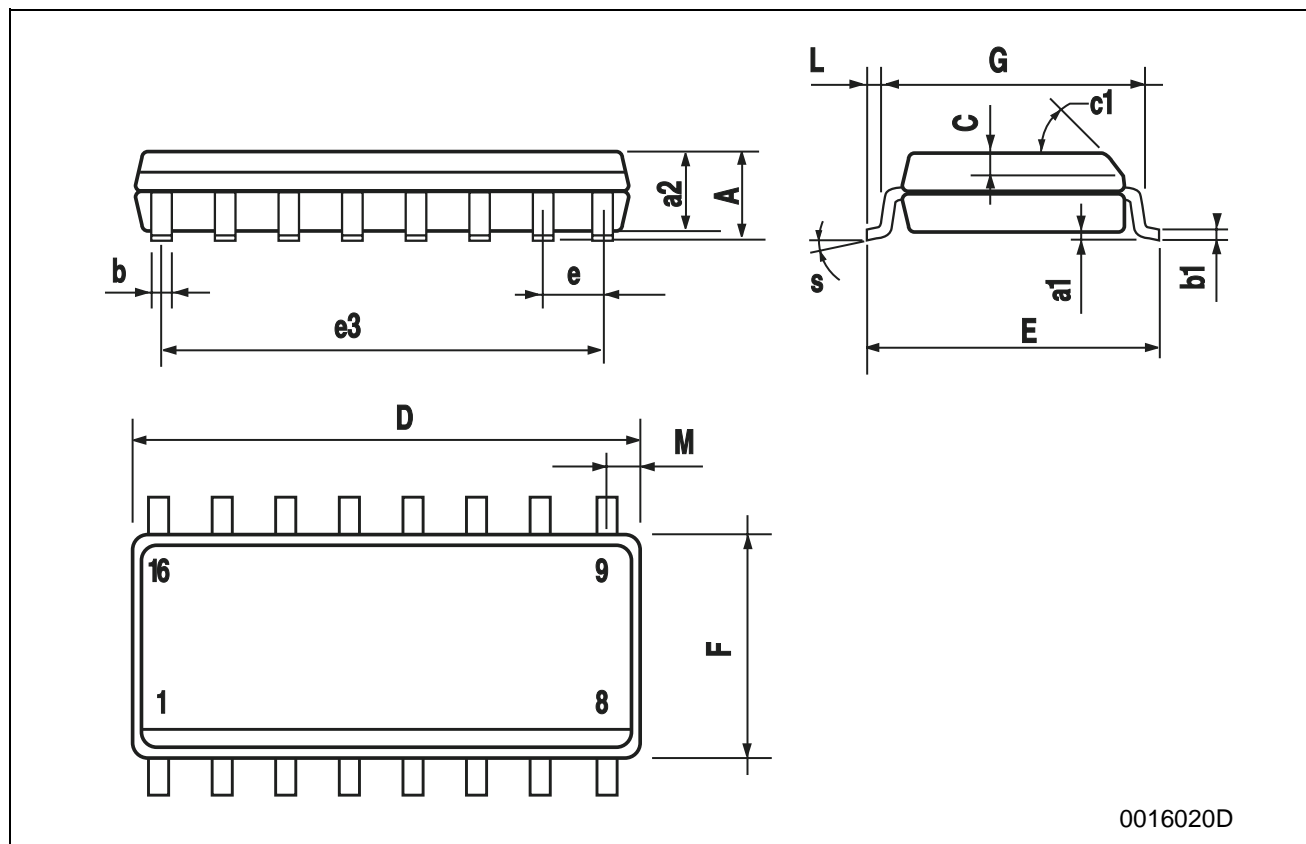

Figure 7: Waveform - Recovery Time ($f=1\text{MHz}$; 50% duty cycle)

SO-16 MECHANICAL DATA

DIM.	mm.			inch		
	MIN.	TYP	MAX.	MIN.	TYP.	MAX.
A			1.75			0.068
a1	0.1		0.25	0.004		0.010
a2			1.64			0.063
b	0.35		0.46	0.013		0.018
b1	0.19		0.25	0.007		0.010
C		0.5			0.019	
c1	45° (typ.)					
D	9.8		10	0.385		0.393
E	5.8		6.2	0.228		0.244
e		1.27			0.050	
e3		8.89			0.350	
F	3.8		4.0	0.149		0.157
G	4.6		5.3	0.181		0.208
L	0.5		1.27	0.019		0.050
M			0.62			0.024
S	8° (max.)					



TSSOP16 MECHANICAL DATA

DIM.	mm.			inch		
	MIN.	TYP	MAX.	MIN.	TYP.	MAX.
A			1.2			0.047
A1	0.05		0.15	0.002	0.004	0.006
A2	0.8	1	1.05	0.031	0.039	0.041
b	0.19		0.30	0.007		0.012
c	0.09		0.20	0.004		0.0079
D	4.9	5	5.1	0.193	0.197	0.201
E	6.2	6.4	6.6	0.244	0.252	0.260
E1	4.3	4.4	4.48	0.169	0.173	0.176
e		0.65 BSC			0.0256 BSC	
K	0°		8°	0°		8°
L	0.45	0.60	0.75	0.018	0.024	0.030

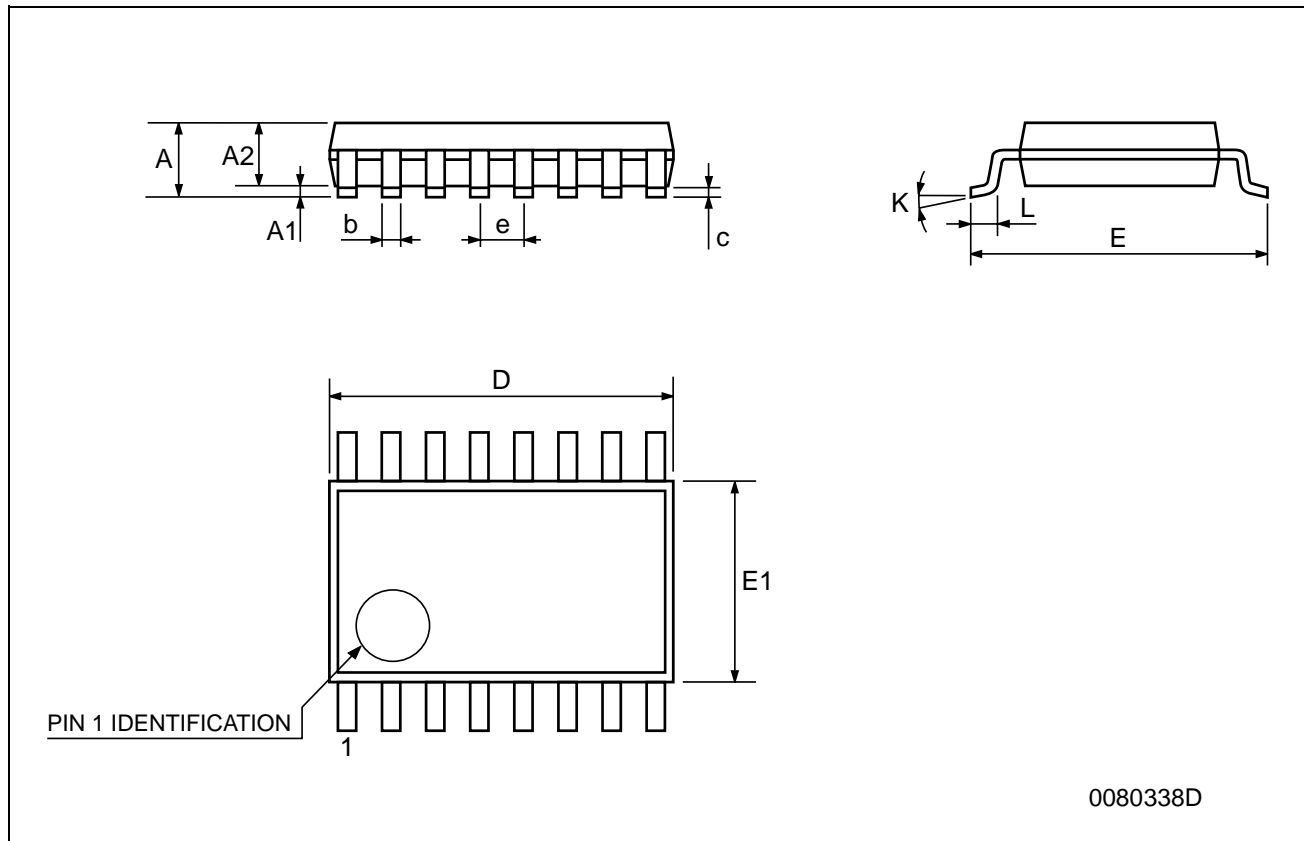

Tape & Reel SO-16 MECHANICAL DATA

DIM.	mm.			inch		
	MIN.	TYP	MAX.	MIN.	TYP.	MAX.
A			330			12.992
C	12.8		13.2	0.504		0.519
D	20.2			0.795		
N	60			2.362		
T			22.4			0.882
Ao	6.45		6.65	0.254		0.262
Bo	10.3		10.5	0.406		0.414
Ko	2.1		2.3	0.082		0.090
Po	3.9		4.1	0.153		0.161
P	7.9		8.1	0.311		0.319

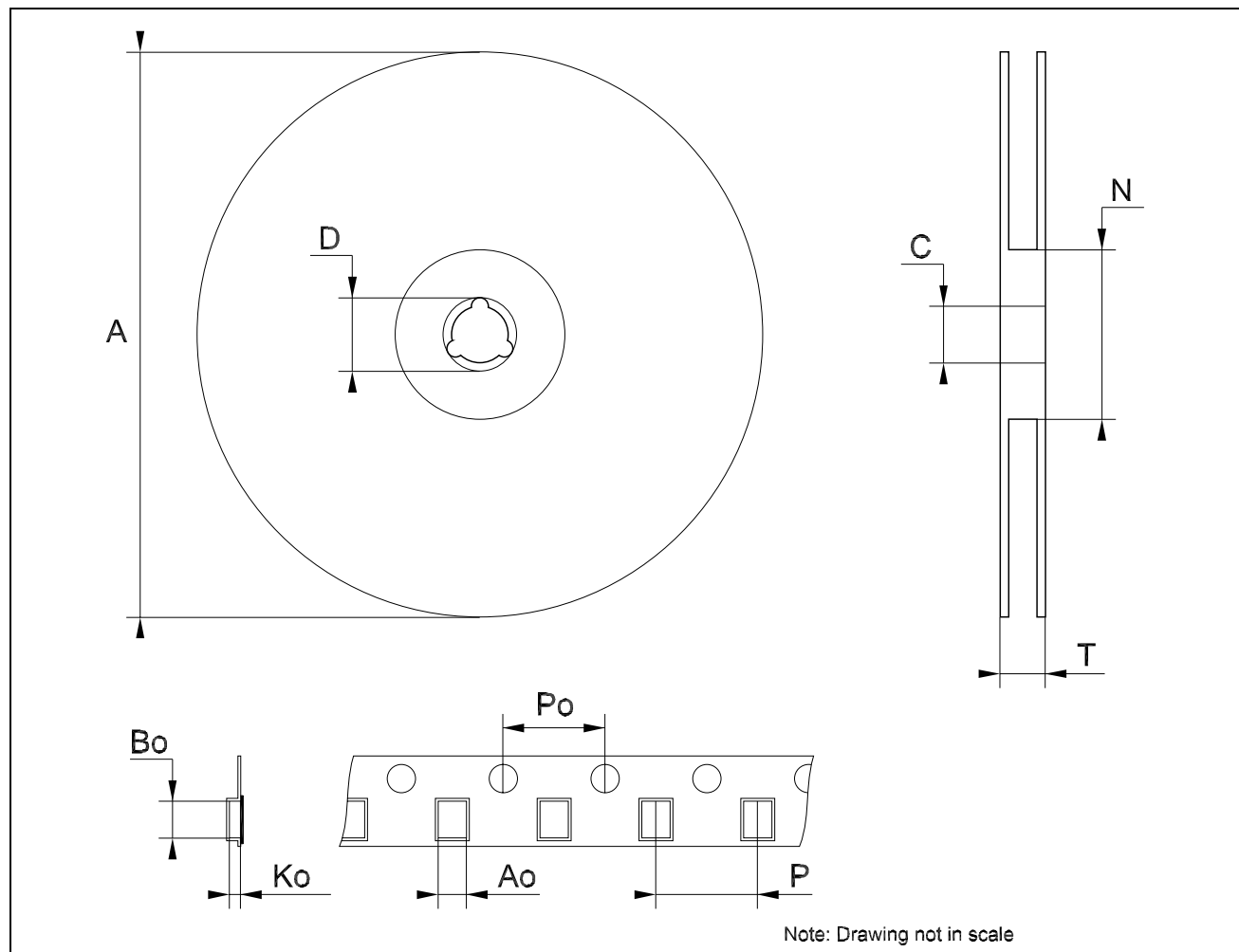

Tape & Reel TSSOP16 MECHANICAL DATA

DIM.	mm.			inch		
	MIN.	TYP.	MAX.	MIN.	TYP.	MAX.
A			330			12.992
C	12.8		13.2	0.504		0.519
D	20.2			0.795		
N	60			2.362		
T			22.4			0.882
Ao	6.7		6.9	0.264		0.272
Bo	5.3		5.5	0.209		0.217
Ko	1.6		1.8	0.063		0.071
Po	3.9		4.1	0.153		0.161
P	7.9		8.1	0.311		0.319

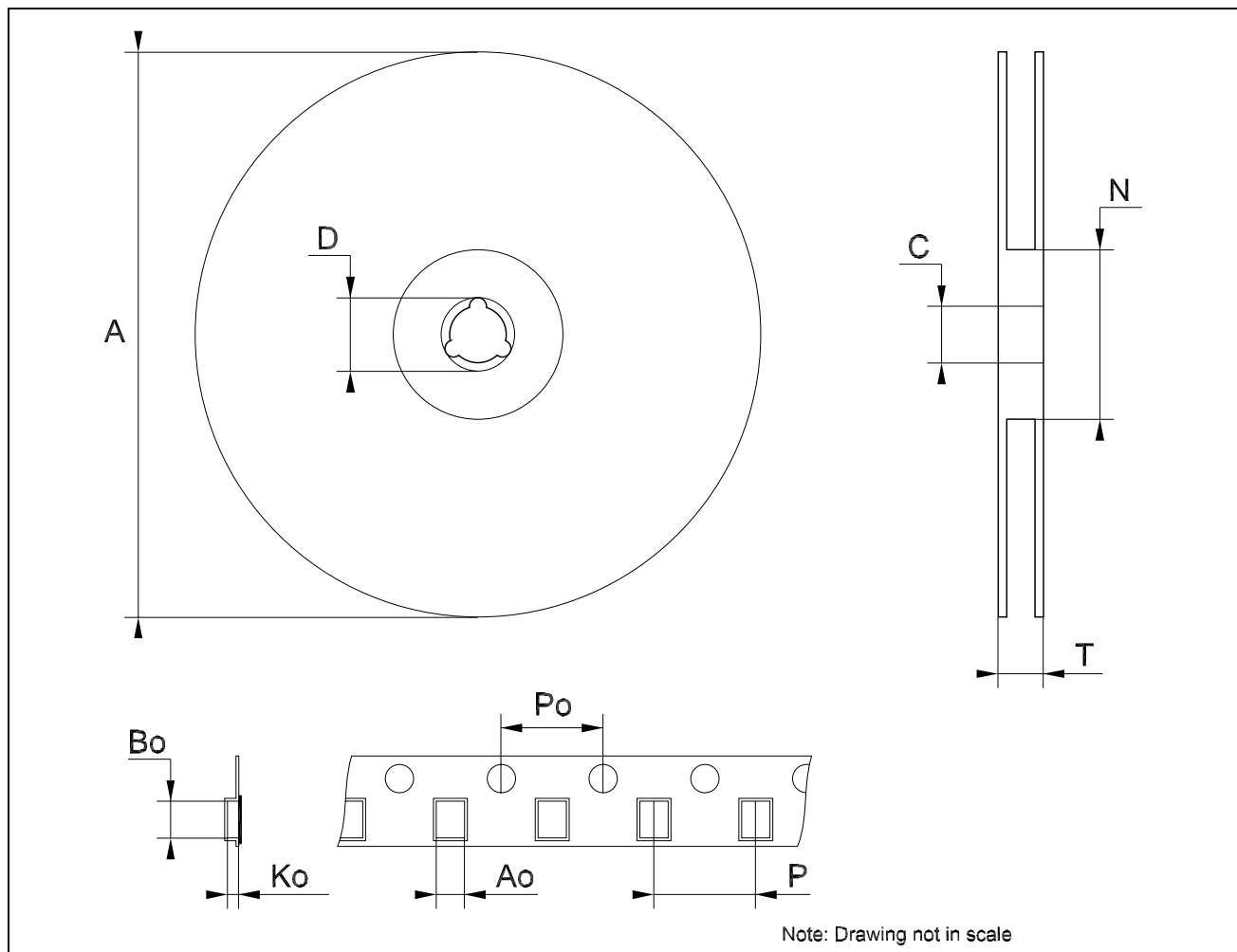

Table 10: Revision History

Date	Revision	Description of Changes
12-Nov-2004	4	Order Codes Revision - pag. 1.

Information furnished is believed to be accurate and reliable. However, STMicroelectronics assumes no responsibility for the consequences of use of such information nor for any infringement of patents or other rights of third parties which may result from its use. No license is granted by implication or otherwise under any patent or patent rights of STMicroelectronics. Specifications mentioned in this publication are subject to change without notice. This publication supersedes and replaces all information previously supplied. STMicroelectronics products are not authorized for use as critical components in life support devices or systems without express written approval of STMicroelectronics.

The ST logo is a registered trademark of STMicroelectronics

All other names are the property of their respective owners

© 2004 STMicroelectronics - All Rights Reserved

STMicroelectronics group of companies

Australia - Belgium - Brazil - Canada - China - Czech Republic - Finland - France - Germany - Hong Kong - India - Israel - Italy - Japan - Malaysia - Malta - Morocco - Singapore - Spain - Sweden - Switzerland - United Kingdom - United States of America

www.st.com