

## Features

- High speed, low power, first-in first-out (FIFO) memories
  - 16 K x 18 (CY7C4265)
- 0.5 micron CMOS for optimum speed and power
- High speed 100 MHz operation (10 ns read/write cycle times)
- Low power —  $I_{CC} = 45 \text{ mA}$
- Fully asynchronous and simultaneous read and write operation
- Empty, full, half full, and programmable almost empty and almost full status flags
- TTL compatible
- Retransmit function
- Output enable ( $\overline{OE}$ ) pins
- Independent read and write enable pins
- Center power and ground pins for reduced noise
- Supports free-running 50 percent duty cycle clock inputs
- Width and depth expansion capability
- 64-pin TQFP and 64-pin STQFP
- Pin-compatible Density Upgrade to CY7C42X5 family
- Pin-compatible density upgrade to IDT72205/15/25/35/45
- Pb-free packages available

## Functional Description

### Logic Block Diagram

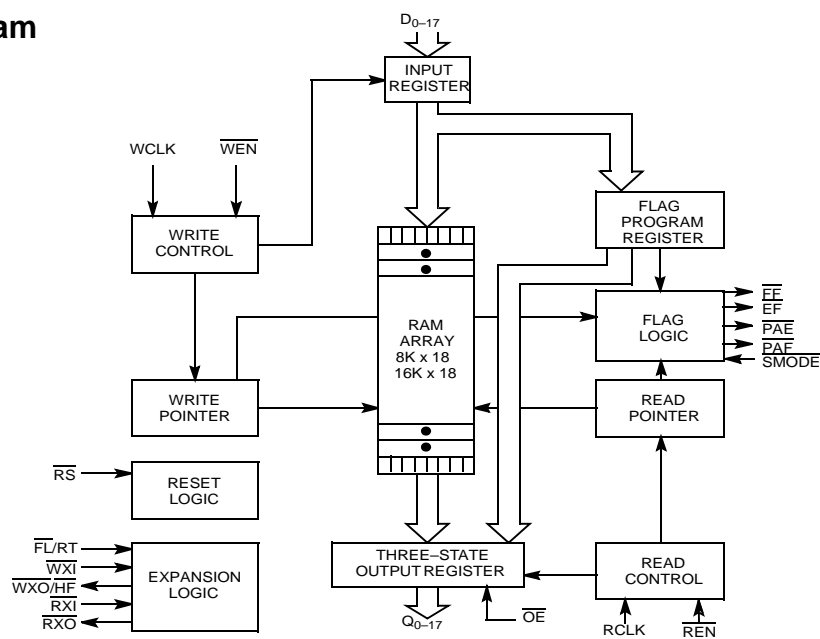

The CY7C4265 are high speed, low power, first-in first-out (FIFO) memories with clocked read and write interfaces. All are 18 bits wide and are pin/functionally compatible to the CY7C42X5 Synchronous FIFO family. The CY7C4265 can be cascaded to increase FIFO depth. Programmable features include Almost Full/Almost Empty flags. These FIFOs provide solutions for a wide variety of data buffering needs, including high speed data acquisition, multiprocessor interfaces, and communications buffering.

These FIFOs have 18-bit input and output ports that are controlled by separate clock and enable signals. The input port is controlled by a free running Clock (WCLK) and a Write Enable pin (WEN). When WEN is asserted, data is written into the FIFO on the rising edge of the WCLK signal. While WEN is held active, data is continually written into the FIFO on each cycle. The output port is controlled in a similar manner by a free-running Read Clock (RCLK) and a Read Enable pin (REN). In addition, the CY7C4265 have an Output Enable pin (OE). The read and write clocks may be tied together for single-clock operation or the two clocks may be run independently for asynchronous read/write applications. Clock frequencies up to 100 MHz are achievable.

Retransmit and Synchronous Almost Full/Almost Empty flag features are available on these devices. Depth expansion is possible using the Cascade Input (WXI, RXI), Cascade Output (WXO, RXO), and First Load (FL) pins. The WXO and RXO pins are connected to the WXI and RXI pins of the next device, and the WXO and RXO pins of the last device should be connected to the WXI and RXI pins of the first device. The FL pin of the first device is tied to  $V_{SS}$  and the FL pin of all the remaining devices should be tied to  $V_{CC}$ .

## Contents

<b>Pin Configurations</b> .....	<b>3</b>	Empty Flag .....	16
<b>Pin Description</b> .....	<b>3</b>	Programmable Almost Empty/Almost Full Flag .....	16
<b>Maximum Ratings</b> .....	<b>5</b>	<b>Retransmit</b> .....	<b>17</b>
<b>Operating Range</b> .....	<b>5</b>	<b>Width Expansion Configuration</b> .....	<b>18</b>
<b>Electrical Characteristics Over the Operating Range</b> ...	<b>5</b>	<b>Depth Expansion Configuration</b>	
<b>Capacitance</b> .....	<b>5</b>	<b>(with Programmable Flags)</b> .....	<b>18</b>
<b>Switching Characteristics Over the Operating Range</b> ..	<b>6</b>	<b>Ordering Information</b> .....	<b>21</b>
<b>Switching Waveforms</b> .....	<b>8</b>	Ordering Code Definitions .....	21
<b>Architecture</b> .....	<b>16</b>	<b>Package Diagrams</b> .....	<b>22</b>
<b>Resetting the FIFO</b> .....	<b>16</b>	<b>Document History Page</b> .....	<b>24</b>
<b>FIFO Operation</b> .....	<b>16</b>	<b>Sales, Solutions, and Legal Information</b> .....	<b>25</b>
<b>Programming</b> .....	<b>16</b>	Products .....	25
<b>Flag Operation</b> .....	<b>16</b>	PSoC Solutions .....	25
Full Flag .....	16		

## Pin Configurations

Figure 1. 64-Pin TQFP/STQFP (Top View)

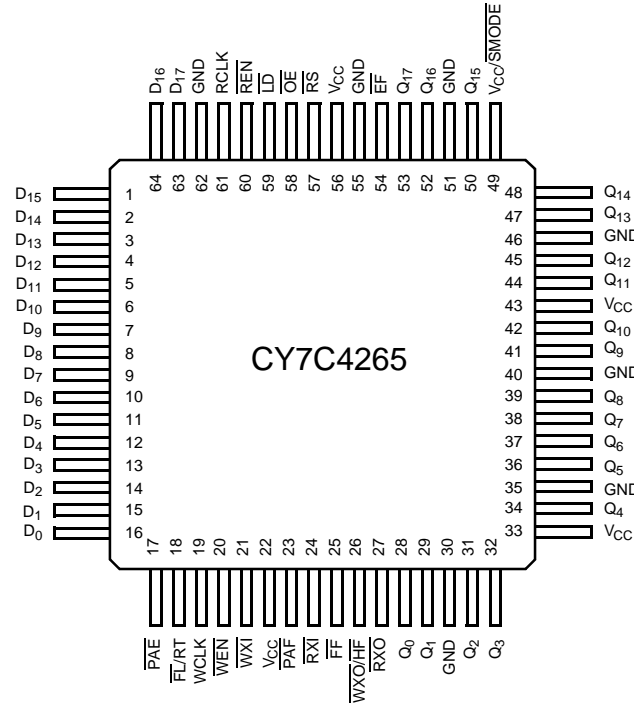

## Pin Description

The CY7C4265 provides five status pins. These pins are decoded to determine one of five states: Empty, Almost Empty, Half Full, Almost Full, and Full. The Half Full flag shares the WXO pin. This flag is valid in the standalone and width-expansion configurations. In the depth expansion, this pin provides the expansion out (WXO) information that is used to signal the next FIFO when it is activated.

The Empty and Full flags are synchronous, that is, they change state relative to either the Read Clock (RCLK) or the Write Clock

(WCLK). When entering or exiting the Empty states, the flag is updated exclusively by the RCLK. The flag denoting Full states is updated exclusively by WCLK. The synchronous flag architecture guarantees that the flags remain valid from one clock cycle to the next. The Almost Empty/Almost Full flags become synchronous if the V<sub>CC</sub>/SMODE is tied to V<sub>SS</sub>. All configurations are fabricated using an advanced 0.5μ CMOS technology. Input ESD protection is greater than 2001V, and latch up is prevented by the use of guard rings.

Table 1. Selection Guide

Description		7C4255/65-10	7C4255/65/65A-15	7C4255/65-25	7C4255/65-35
Maximum Frequency (MHz)		100	66.7	40	28.6
Maximum Access Time (ns)		8	10	15	20
Minimum Cycle Time (ns)		10	15	25	35
Minimum Data or Enable Set-Up (ns)		3	4	6	7
Minimum Data or Enable Hold (ns)		0.5	1	1	2
Maximum Flag Delay (ns)		8	10	15	20
Active Power Supply Current (I <sub>CC1</sub> ) (mA)	Commercial	45	45	45	45
	Industrial	50	50	50	50

Table 2. Density and Package

Description	CY7C4265
Density	16K x18
Package	64-pin TQFP, STQFP

**Table 3. Pin Definitions**

Signal Name	Description	I/O	Function
$D_{0-17}$	Data Inputs	I	Data inputs for an 18-bit bus.
$Q_{0-17}$	Data Outputs	O	Data outputs for an 18-bit bus.
$\overline{WEN}$	Write Enable	I	Enables the WCLK input.
$\overline{REN}$	Read Enable	I	Enables the RCLK input.
WCLK	Write Clock	I	The rising edge clocks data into the FIFO when $\overline{WEN}$ is LOW and the FIFO is not Full. When LD is asserted, WCLK writes data into the programmable flag-offset register.
RCLK	Read Clock	I	The rising edge clocks data out of the FIFO when $\overline{REN}$ is LOW and the FIFO is not Empty. When LD is asserted, RCLK reads data out of the programmable flag-offset register.
$\overline{WXO}/\overline{HF}$	Write Expansion Out/Half Full Flag	O	Dual-Mode Pin: Single device or width expansion – Half Full status flag. Cascaded – Write Expansion Out signal, connected to $\overline{WXI}$ of next device.
$\overline{EF}$	Empty Flag	O	When $\overline{EF}$ is LOW, the FIFO is empty. $\overline{EF}$ is synchronized to RCLK.
$\overline{FF}$	Full Flag	O	When $\overline{FF}$ is LOW, the FIFO is full. $\overline{FF}$ is synchronized to WCLK.
$\overline{PAE}$	Programmable Almost Empty	O	When $\overline{PAE}$ is LOW, the FIFO is almost empty based on the almost-empty offset value programmed into the FIFO. $\overline{PAE}$ is asynchronous when $V_{CC}/\overline{SMODE}$ is tied to $V_{CC}$ ; it is synchronized to RCLK when $V_{CC}/\overline{SMODE}$ is tied to $V_{SS}$ .
$\overline{PAF}$	Programmable Almost Full	O	When $\overline{PAF}$ is LOW, the FIFO is almost full based on the almost full offset value programmed into the FIFO. $\overline{PAF}$ is asynchronous when $V_{CC}/\overline{SMODE}$ is tied to $V_{CC}$ ; it is synchronized to WCLK when $V_{CC}/\overline{SMODE}$ is tied to $V_{SS}$ .
$\overline{LD}$	Load	I	When $\overline{LD}$ is LOW, $D_{0-17}$ ( $Q_{0-17}$ ) are written (read) into (from) the programmable-flag-offset register.
$\overline{FL}/\overline{RT}$	First Load/Retransmit	I	Dual-Mode Pin: Cascaded – The first device in the daisy chain has $\overline{FL}$ tied to $V_{SS}$ ; all other devices has FL tied to $V_{CC}$ . In standard mode or width expansion, FL is tied to $V_{SS}$ on all devices. Not Cascaded – Tied to $V_{SS}$ . Retransmit function is also available in stand-alone mode by strobing RT.
$\overline{WXI}$	Write Expansion Input	I	Cascaded – Connected to $\overline{WXO}$ of previous device. Not Cascaded – Tied to $V_{SS}$ .
$\overline{RXI}$	Read Expansion Input	I	Cascaded – Connected to $\overline{RXO}$ of previous device. Not Cascaded – Tied to $V_{SS}$ .
$\overline{RXO}$	Read Expansion Output	O	Cascaded – Connected to $\overline{RXI}$ of next device.
RS	Reset	I	Resets device to empty condition. A reset is required before an initial read or write operation after power up.
$\overline{OE}$	Output Enable	I	When $\overline{OE}$ is LOW, the FIFO's data outputs drive the bus to which they are connected. If $\overline{OE}$ is HIGH, the FIFO's outputs are in High Z (high-impedance) state.
$V_{CC}/\overline{SMODE}$	Synchronous Almost Empty/Almost Full Flags	I	Dual-Mode Pin: Asynchronous Almost Empty/Almost Full flags – tied to $V_{CC}$ . Synchronous Almost Empty/Almost Full flags – tied to $V_{SS}$ . (Almost Empty synchronized to RCLK, Almost Full synchronized to WCLK.)

### Maximum Ratings

Exceeding maximum ratings may impair the useful life of the device. These user guidelines are not tested.<sup>[2]</sup>

- Storage Temperature ..... -65°C to +150°C
- Ambient Temperature with Power Applied. -55°C to +125°C
- Supply Voltage to Ground Potential.....-0.5V to +7.0V
- DC Voltage Applied to Outputs in High Z State .....-0.5V to +7.0V
- DC Input Voltage ..... -0.5V to V<sub>CC</sub>+0.5V

- Output Current into Outputs (LOW)..... 20 mA
- Static Discharge Voltage..... >2001V (per MIL-STD-883, Method 3015)
- Latch Up Current ..... >200 mA

### Operating Range

Range	Ambient Temperature <sup>[3]</sup>	V <sub>CC</sub>
Commercial	0°C to +70°C	5V ± 10%
Industrial <sup>[4]</sup>	-40°C to +85°C	5V ± 10%

### Electrical Characteristics Over the Operating Range<sup>[4]</sup>

Parameter	Description	Test Conditions	7C42X5-10		7C42X5, 7C4265A-15		7C42X5-25		7C42X5-35		Unit
			Min	Max	Min	Max	Min	Max	Min	Max	
V <sub>OH</sub>	Output HIGH Voltage	V <sub>CC</sub> = Min., I <sub>OH</sub> = -2.0 mA	2.4		2.4		2.4		2.4		V
V <sub>OL</sub>	Output LOW Voltage	V <sub>CC</sub> = Min., I <sub>OL</sub> = 8.0 mA		0.4		0.4		0.4		0.4	V
V <sub>IH</sub> <sup>[5]</sup>	Input HIGH Voltage		2.0	V <sub>CC</sub>	2.0	V <sub>CC</sub>	2.0	V <sub>CC</sub>	2.0	V <sub>CC</sub>	V
V <sub>IL</sub> <sup>[5]</sup>	Input LOW Voltage		-0.5	0.8	-0.5	0.8	-0.5	0.8	-0.5	0.8	V
I <sub>IX</sub>	Input Leakage Current	V <sub>CC</sub> = Max.	-10	+10	-10	+10	-10	+10	-10	+10	µA
I <sub>OZL</sub> I <sub>OZH</sub>	Output OFF, High Z Current	OE ≥ V <sub>IH</sub> , V <sub>SS</sub> < V <sub>O</sub> < V <sub>CC</sub>	-10	+10	-10	+10	-10	+10	-10	+10	µA
I <sub>CC1</sub> <sup>[6]</sup>	Active Power Supply Current		Commercial	45		45		45		45	mA
			Industrial		50		50		50		50
I <sub>CC2</sub> <sup>[7]</sup>	Average Standby Current		Commercial	10		10		10		10	mA
			Industrial		15		15		15		15

### Capacitance<sup>[8, 9]</sup>

Parameter	Description	Test Conditions	Max	Unit
C <sub>IN</sub>	Input Capacitance	T <sub>A</sub> = 25°C, f = 1 MHz, V <sub>CC</sub> = 5.0V	5	pF
C <sub>OUT</sub>	Output Capacitance		7	pF

**Notes**

2. The Voltage on any input or I/O pin cannot exceed the power pin during power up.
3. T<sub>A</sub> is the "Instant On" case temperature.
4. See the last page of this specification for Group A subgroup testing information.
5. The V<sub>IH</sub> and V<sub>IL</sub> specifications apply for all inputs except WXI, RXI. The WXI, RXI pin is not a TTL input. It is connected to either  $\overline{RXO}$ ,  $\overline{WXO}$  of the previous device or V<sub>SS</sub>.
6. Input signals switch from 0V to 3V with a rise/fall time of less than 3 ns, clocks and clock enables switch at 20 MHz, while data inputs switch at 10 MHz. Outputs are unloaded. I<sub>CC1</sub>(typical) = (25 mA + (freq - 20 MHz) \* (1.0 mA/MHz)).
7. All inputs = V<sub>CC</sub> - 0.2V, except RCLK and WCLK (which are switching at frequency = 20 MHz), and  $\overline{FL/RT}$  which is at V<sub>SS</sub>. All outputs are unloaded.
8. Tested initially and after any design changes that may affect these parameters.
9. Tested initially and after any process changes that may affect these parameters.

Figure 2. AC Test Loads and Waveforms<sup>[10, 11]</sup>

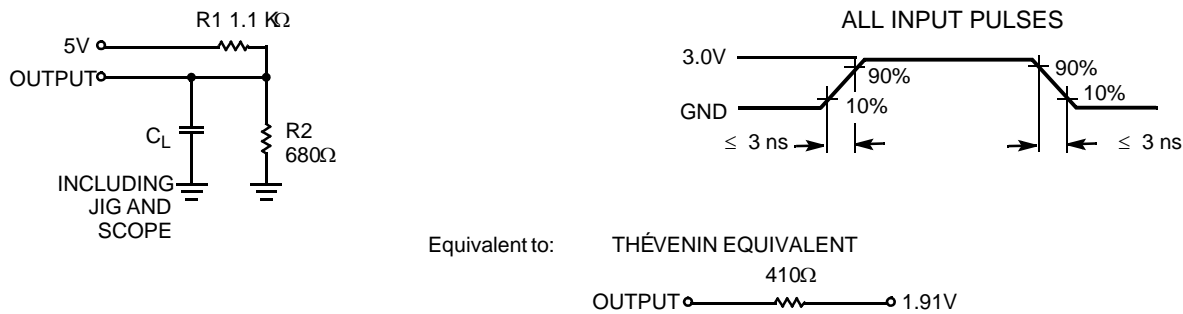

**Switching Characteristics** Over the Operating Range

Parameter	Description	7C42X5-10		7C42X5, 7C4265A-15		7C42X5-25		7C42X5-35		Unit
		Min	Max	Min	Max	Min	Max	Min	Max	
t <sub>S</sub>	Clock Cycle Frequency		100		66.7		40		28.6	MHz
t <sub>A</sub>	Data Access Time	2	8	2	10	2	15	2	20	ns
t <sub>CLK</sub>	Clock Cycle Time	10		15		25		35		ns
t <sub>CLKH</sub>	Clock HIGH Time	4.5		6		10		14		ns
t <sub>CLKL</sub>	Clock LOW Time	4.5		6		10		14		ns
t <sub>DS</sub>	Data Set Up Time	3		4		6		7		ns
t <sub>DH</sub>	Data Hold Time	0.5		1		1		2		ns
t <sub>ENS</sub>	Enable Set Up Time	3		4		6		7		ns
t <sub>ENH</sub>	Enable Hold Time	0.5		1		1		2		ns
t <sub>RS</sub>	Reset Pulse Width <sup>[12]</sup>	10		15		25		35		ns
t <sub>RSR</sub>	Reset Recovery Time	8		10		15		20		ns
t <sub>RSF</sub>	Reset to Flag and Output Time		10		15		25		35	ns
t <sub>PRT</sub>	Retransmit Pulse Width	30		35		45		55		ns
t <sub>RTR</sub>	Retransmit Recovery Time	60		65		75		85		ns
t <sub>OLZ</sub>	Output Enable to Output in Low Z <sup>[12]</sup>	0		0		0		0		ns
t <sub>OE</sub>	Output Enable to Output Valid	3	7	3	8	3	12	3	15	ns
t <sub>OHZ</sub>	Output Enable to Output in High Z <sup>[13]</sup>	3	7	3	8	3	12	3	15	ns
t <sub>WFF</sub>	Write Clock to Full Flag		8		10		15		20	ns
t <sub>REF</sub>	Read Clock to Empty Flag		8		10		15		20	ns
t <sub>PAFasynch</sub>	Clock to Programmable Almost-Full Flag <sup>[13]</sup> (Asynchronous mode, V <sub>CC</sub> /SMODE tied to V <sub>CC</sub> )		12		16		20		25	ns
t <sub>PAFsynch</sub>	Clock to Programmable Almost-Full Flag (Synchronous mode, V <sub>CC</sub> /SMODE tied to V <sub>SS</sub> )		8		10		15		20	ns
t <sub>PAEasynch</sub>	Clock to Programmable Almost-Empty Flag <sup>[14]</sup> (Asynchronous mode, V <sub>CC</sub> /SMODE tied to V <sub>CC</sub> )		12		16		20		25	ns
t <sub>PAEsynch</sub>	Clock to Programmable Almost-Full Flag (Synchronous mode, V <sub>CC</sub> /SMODE tied to V <sub>SS</sub> )		8		10		15		20	ns
t <sub>HF</sub>	Clock to Half-Full Flag		12		16		20		25	ns

**Switching Characteristics** Over the Operating Range (continued)

Parameter	Description	7C42X5-10		7C42X5, 7C4265A-15		7C42X5-25		7C42X5-35		Unit
		Min	Max	Min	Max	Min	Max	Min	Max	
t <sub>XO</sub>	Clock to Expansion Out		6		10		15		20	ns
t <sub>XI</sub>	Expansion in Pulse Width	4.5		6.5		10		14		ns
t <sub>XIS</sub>	Expansion in Set-Up Time	4		5		10		15		ns
t <sub>SKEW1</sub>	Skew Time between Read Clock and Write Clock for Full Flag	5		6		10		12		ns
t <sub>SKEW2</sub>	Skew Time between Read Clock and Write Clock for Empty Flag	5		6		10		12		ns
t <sub>SKEW3</sub>	Skew Time between Read Clock and Write Clock for Programmable Almost Empty and Programmable Almost Full Flags (Synchronous Mode only)	10		15		18		20		ns

**Notes**

- 10. C<sub>L</sub> = 30 pF for all AC parameters except for t<sub>OHZ</sub>.
- 11. C<sub>L</sub> = 5 pF for t<sub>OHZ</sub>.
- 12. Pulse widths less than minimum values are not enabled.
- 13. Values guaranteed by design, not currently tested.
- 14. t<sub>PAFasynch</sub>, t<sub>PAEasynch</sub> after program register write is not be valid until 5 ns + t<sub>PAF(E)</sub>.

## Switching Waveforms

Figure 3. Write Cycle Timing

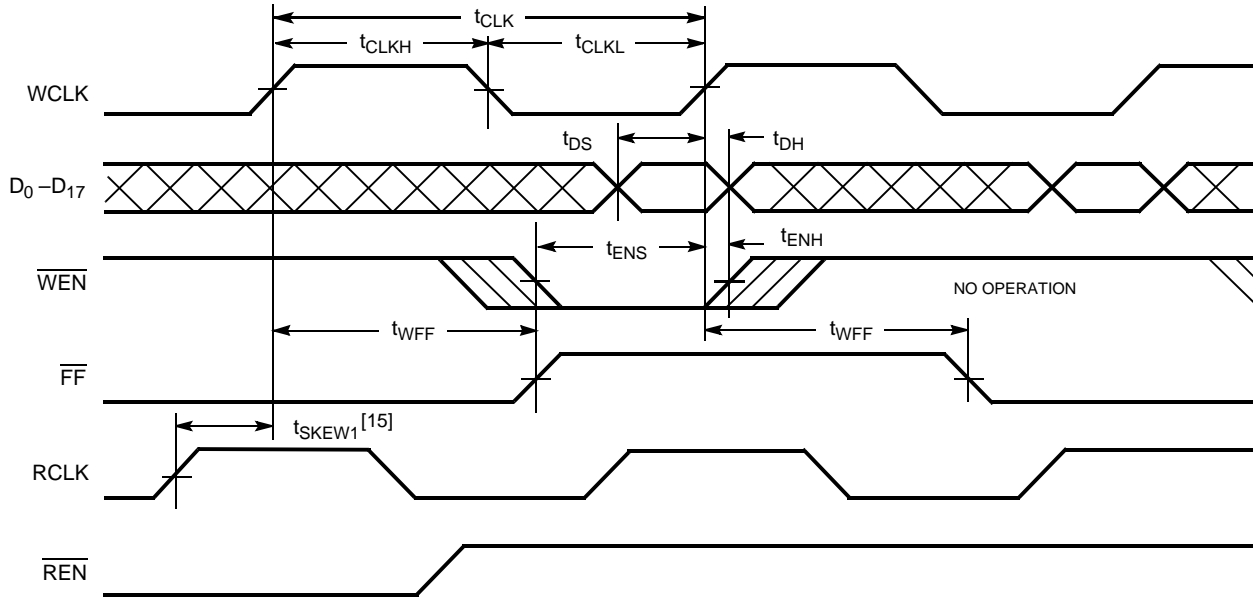
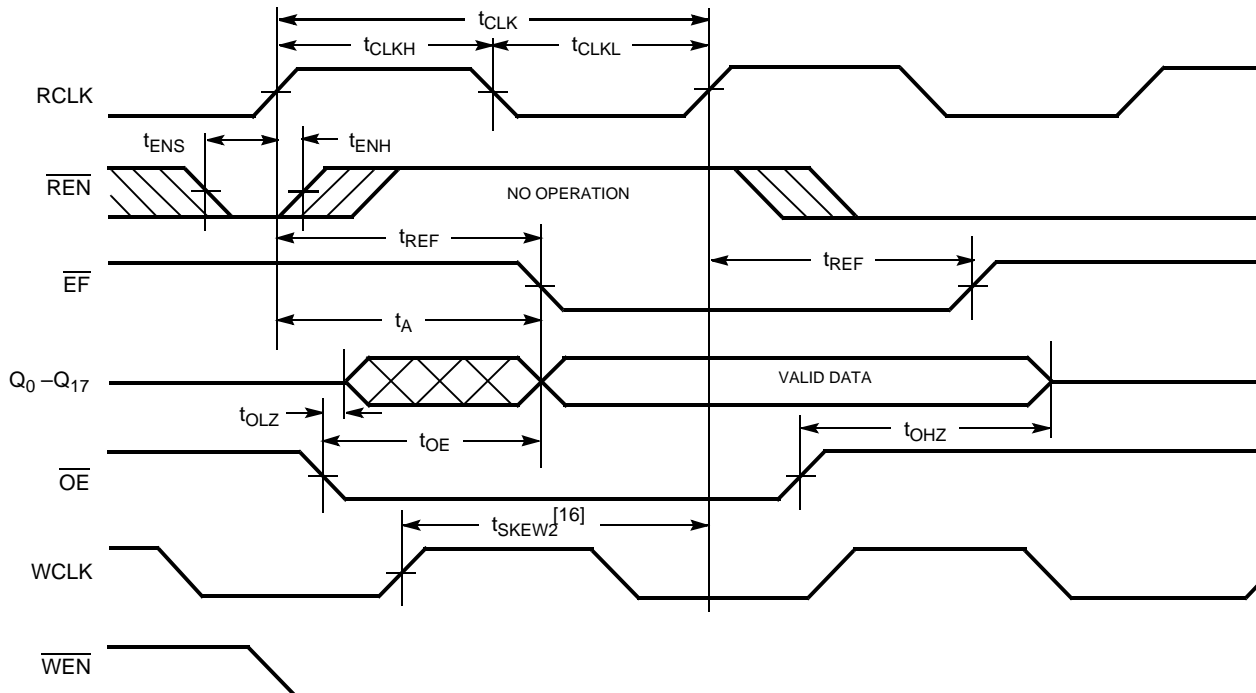

Figure 4. Read Cycle Timing



**Notes**

15.  $t_{SKEW1}$  is the minimum time between a rising RCLK edge and a rising WCLK edge to guarantee that  $\overline{FF}$  goes HIGH during the current clock cycle. If the time between the rising edge of RCLK and the rising edge of WCLK is less than  $t_{SKEW1}$ , then FF may not change state until the next WCLK rising edge.
16.  $t_{SKEW2}$  is the minimum time between a rising WCLK edge and a rising RCLK edge to guarantee that  $\overline{EF}$  goes HIGH during the current clock cycle. If the time between the rising edge of WCLK and the rising edge of RCLK is less than  $t_{SKEW2}$ , then EF may not change state until the next RCLK rising edge.



Switching Waveforms (continued)

Figure 5. Reset Timing<sup>[17]</sup>

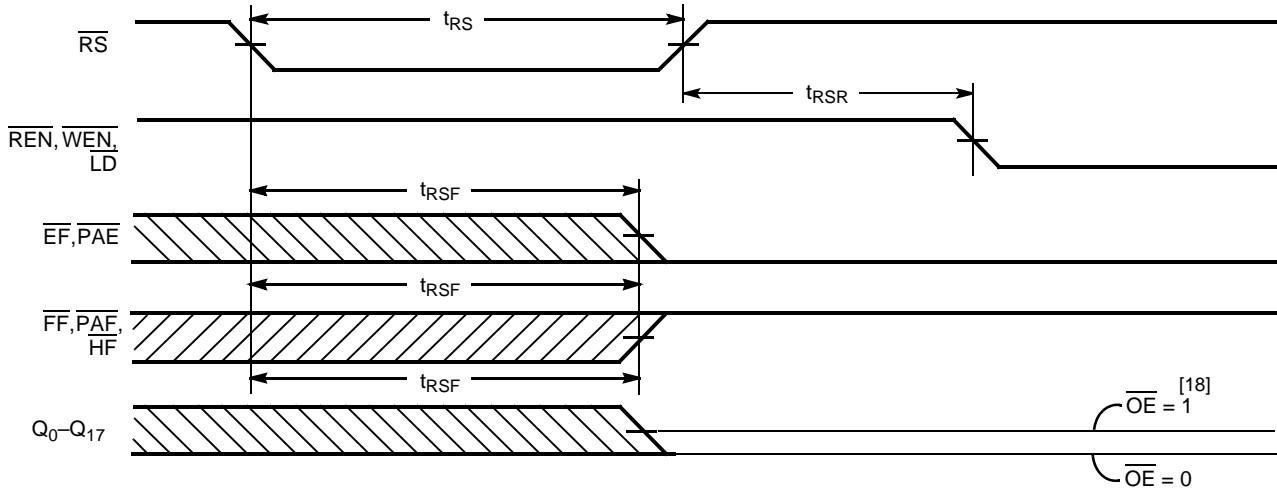
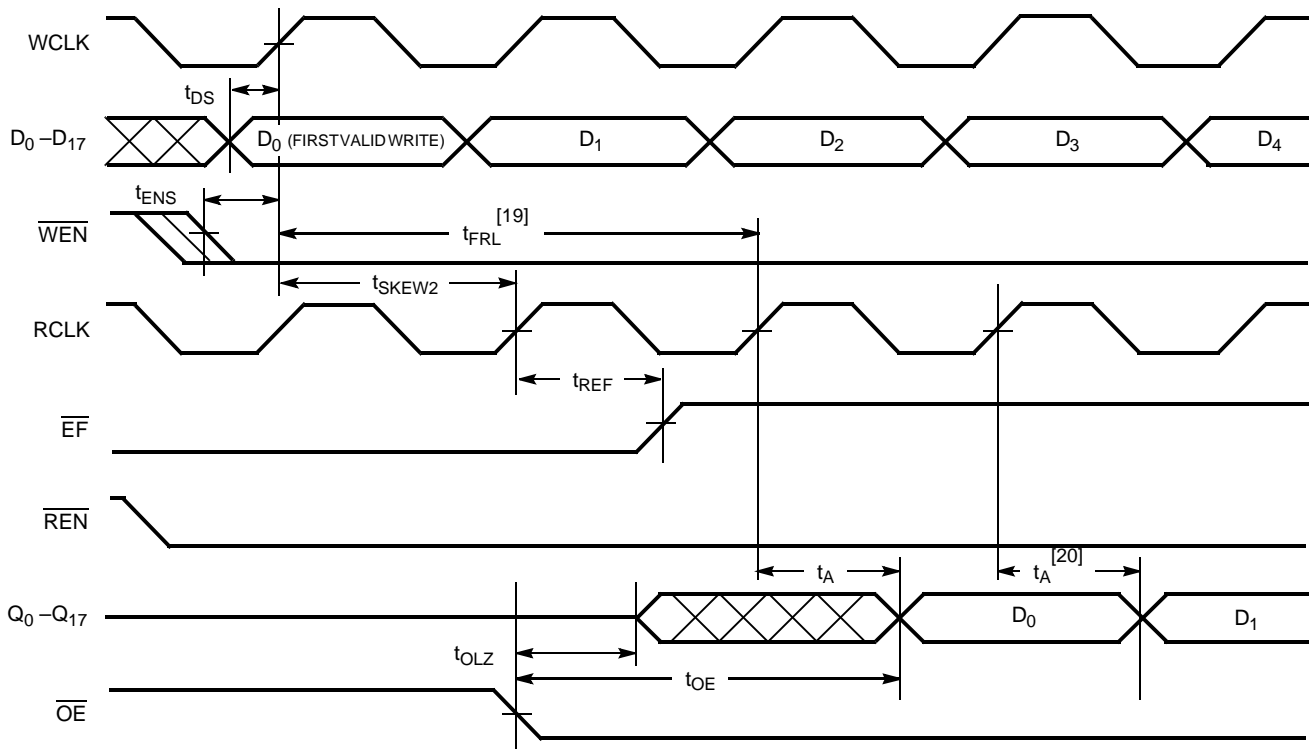

Figure 6. First Data Word Latency after Reset with Simultaneous Read and Write



Notes

17. The clocks (RCLK, WCLK) can be free-running during reset.
18. After reset, the outputs are LOW if  $\overline{OE} = 0$  and three-state if  $\overline{OE} = 1$ .
19. When  $t_{SKEW2} \geq$  minimum specification,  $t_{FRL}$  (maximum) =  $t_{CLK} + t_{SKEW2}$ . When  $t_{SKEW2} <$  minimum specification,  $t_{FRL}$  (maximum) = either  $2 \cdot t_{CLK} + t_{SKEW2}$  or  $t_{CLK} + t_{SKEW2}$ . The Latency Timing applies only at the Empty Boundary (EF = LOW).
20. The first word is available the cycle after  $\overline{EF}$  goes HIGH, always.

Switching Waveforms (continued)

Figure 7. Empty Flag Timing

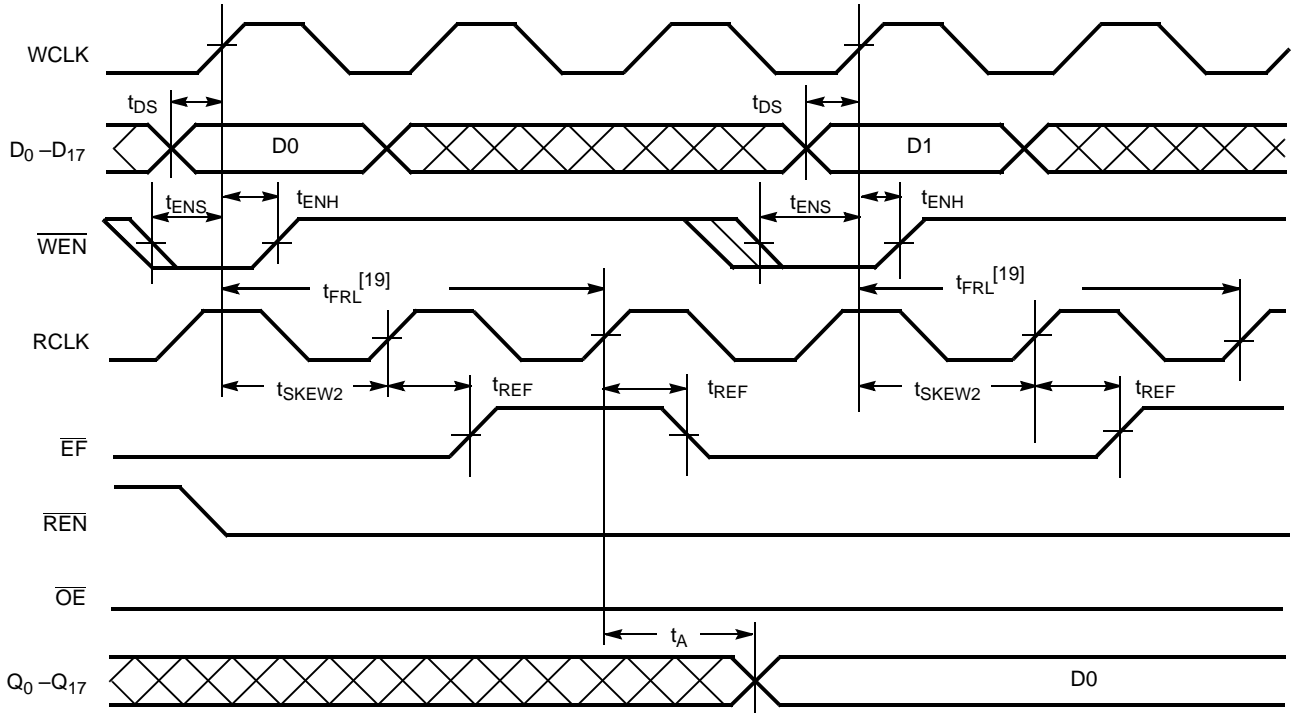
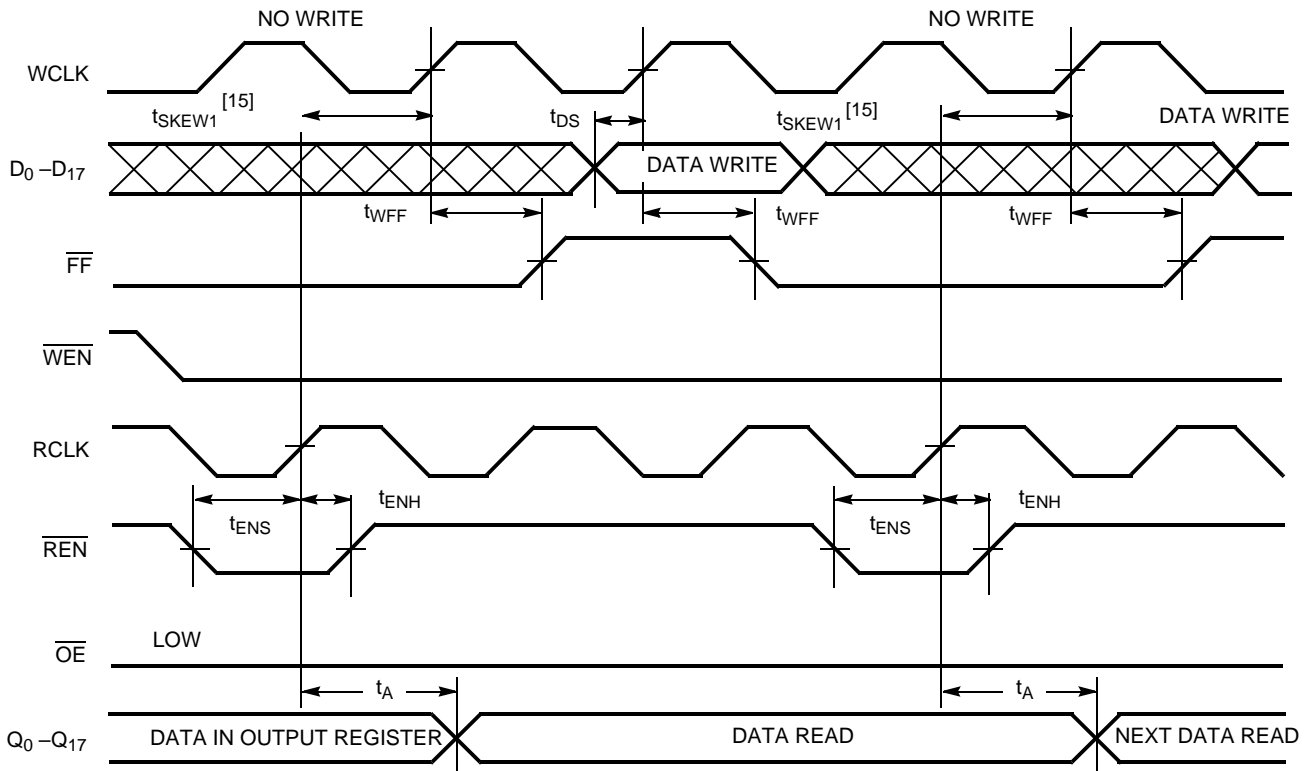

Figure 8. Full Flag Timing



Switching Waveforms (continued)

Figure 9. Half-Full Flag Timing

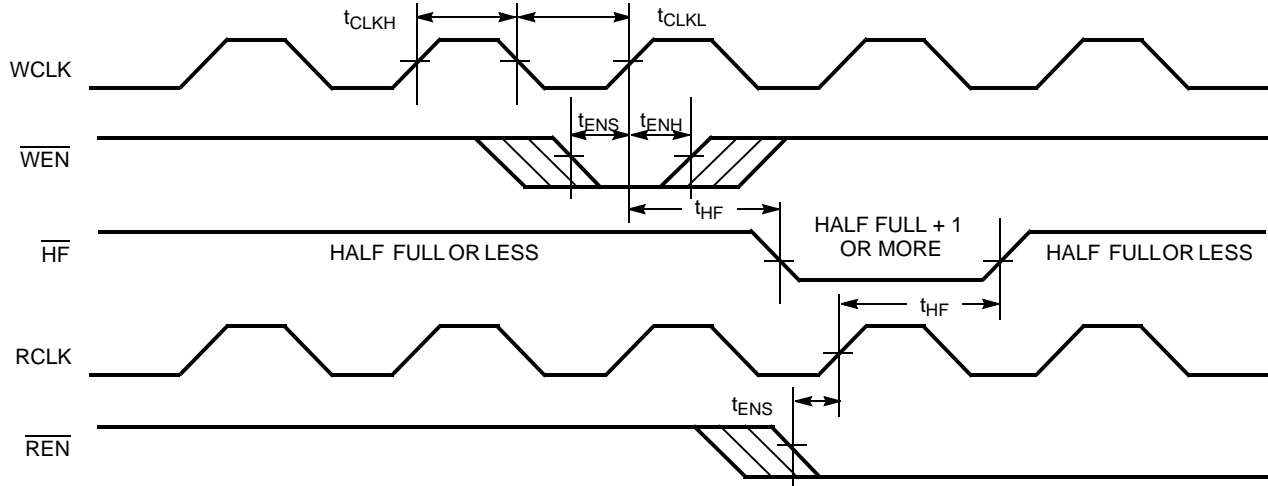
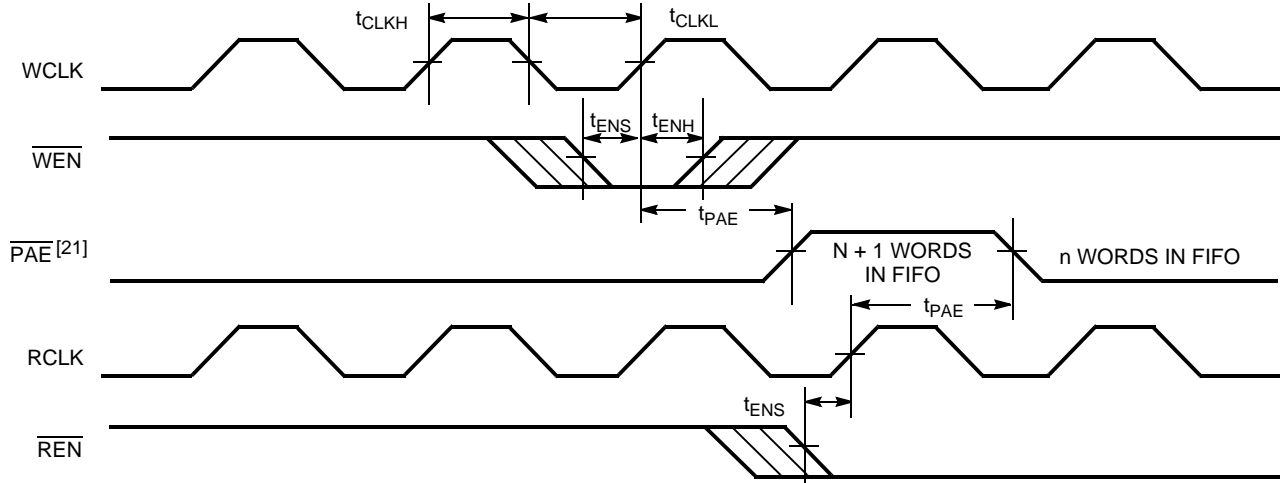

Figure 10. Programmable Almost Empty Flag Timing



Note

21. PAE is offset = n. Number of data words into FIFO already = n.

Switching Waveforms (continued)

Figure 11. Programmable Almost Empty Flag Timing (applies only in  $\overline{\text{SMODE}}$  ( $\overline{\text{SMODE}}$  is LOW))

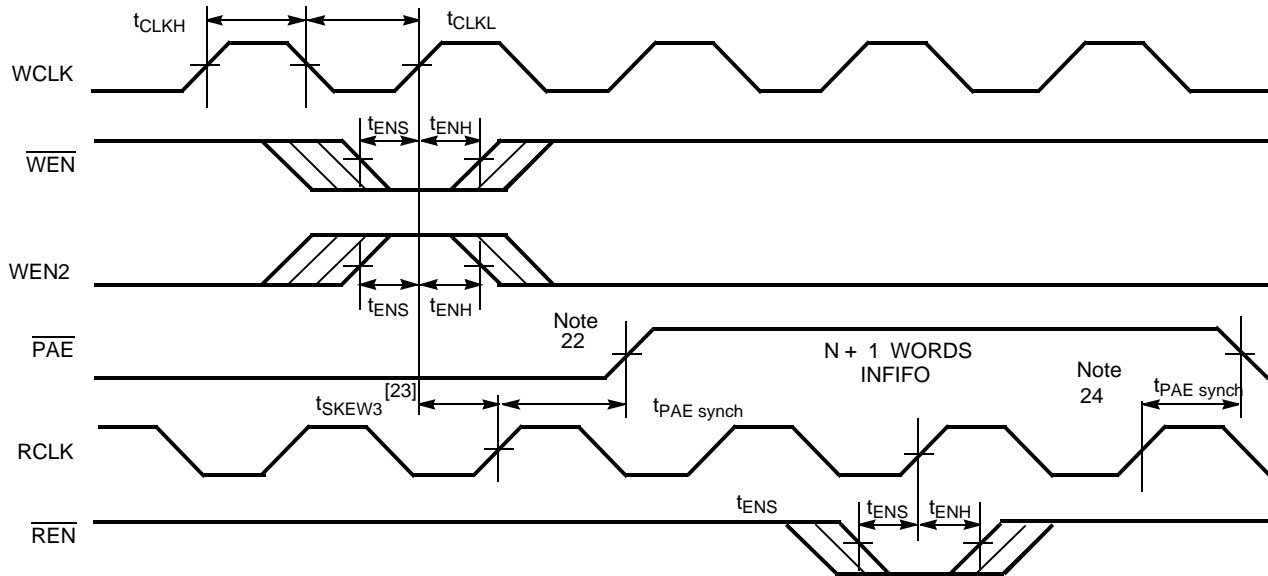
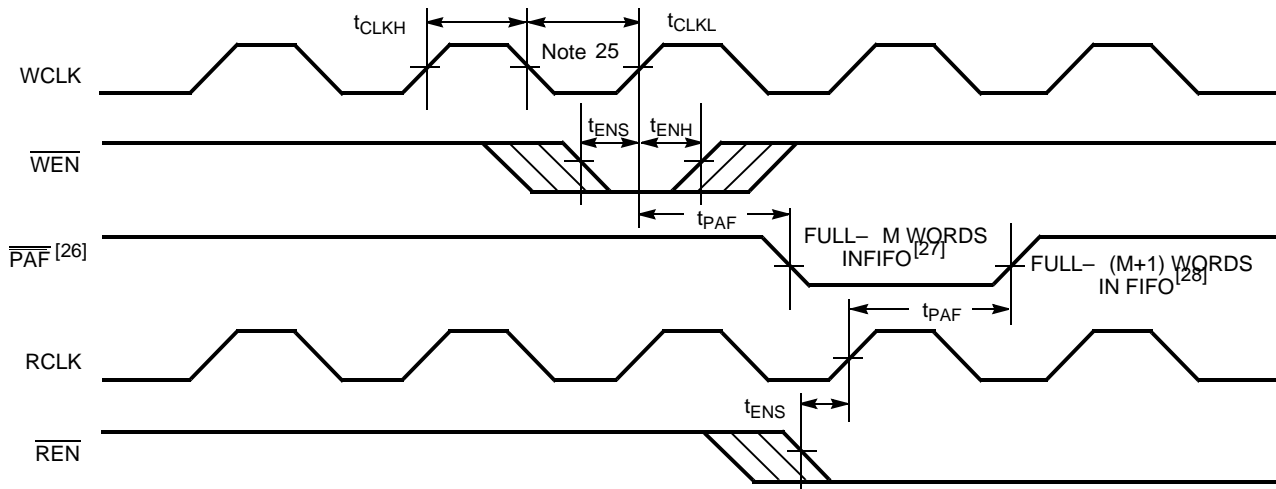

Figure 12. Programmable Almost Full Flag Timing



Notes

- 22. PAE offset = n.
- 23.  $t_{\text{SKEW3}}$  is the minimum time between a rising WCLK and a rising RCLK edge for  $\overline{\text{PAE}}$  to change state during that clock cycle. If the time between the edge of WCLK and the rising RCLK is less than  $t_{\text{SKEW3}}$ , then PAE may not change state until the next RCLK.
- 24. If a read is performed on this rising edge of the read clock, there are Empty + (n-1) words in the FIFO when  $\overline{\text{PAE}}$  goes LOW.
- 25. PAF offset = m. Number of data words written into FIFO already = 8192 - (m + 1) for the CY7C4255 and 16384 - (m + 1) for the CY7C4265/65A.
- 26. PAF is offset = m.
- 27. 16384 - m words in CY7C4265.
- 28. 16384 - (m + 1) CY7C4265.

Switching Waveforms (continued)

Figure 13. Programmable Almost Full Flag Timing (applies only in  $\overline{\text{SMODE}}$  ( $\overline{\text{SMODE}}$  is LOW))

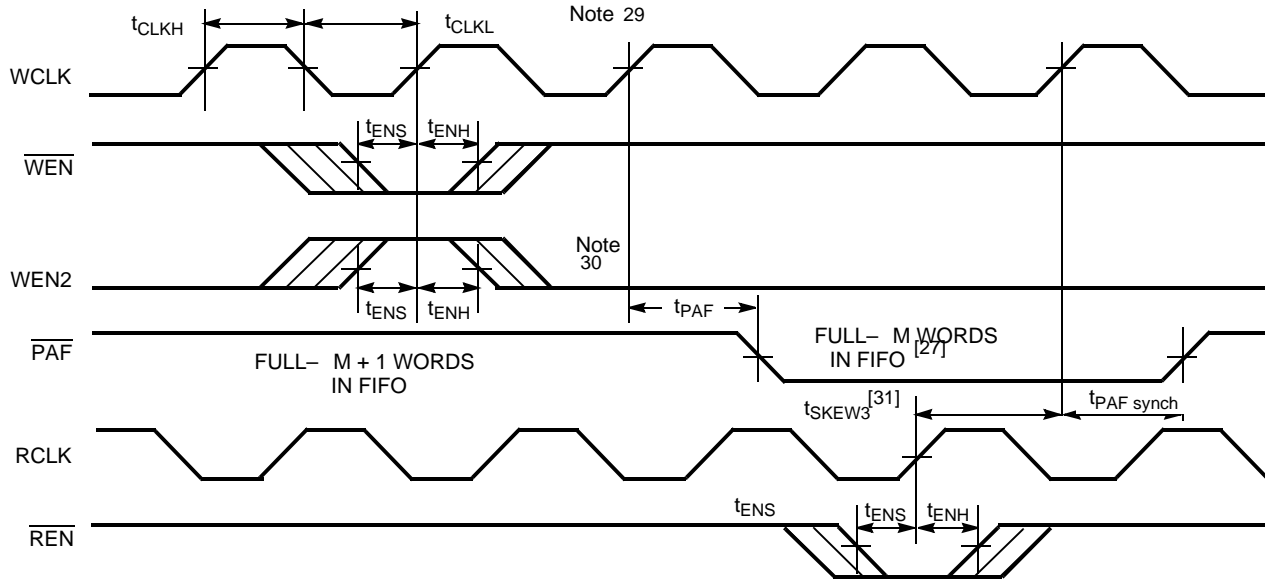
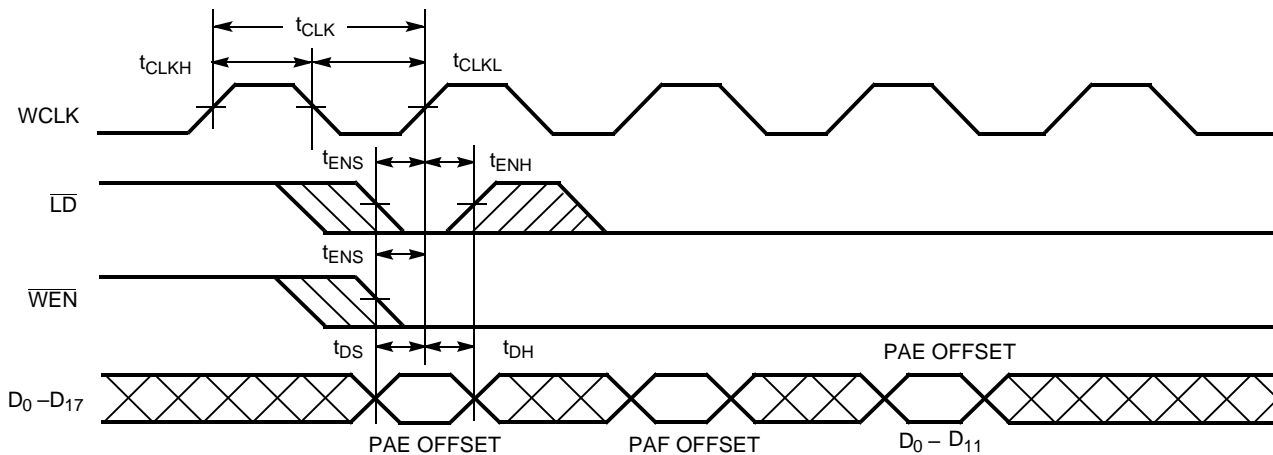

Figure 14. Write Programmable Registers



Notes

29. If a write is performed on this rising edge of the write clock, there are Full - (m - 1) words of the FIFO when  $\overline{\text{PAF}}$  goes LOW.

30. PAF offset = m.

31.  $t_{\text{SKEW3}}$  is the minimum time between a rising RCLK and a rising WCLK edge for  $\overline{\text{PAF}}$  to change state during that clock cycle. If the time between the edge of RCLK and the rising edge of WCLK is less than  $t_{\text{SKEW3}}$ , then  $\overline{\text{PAF}}$  may not change state until the next WCLK rising edge.

Switching Waveforms (continued)

Figure 15. Read Programmable Registers

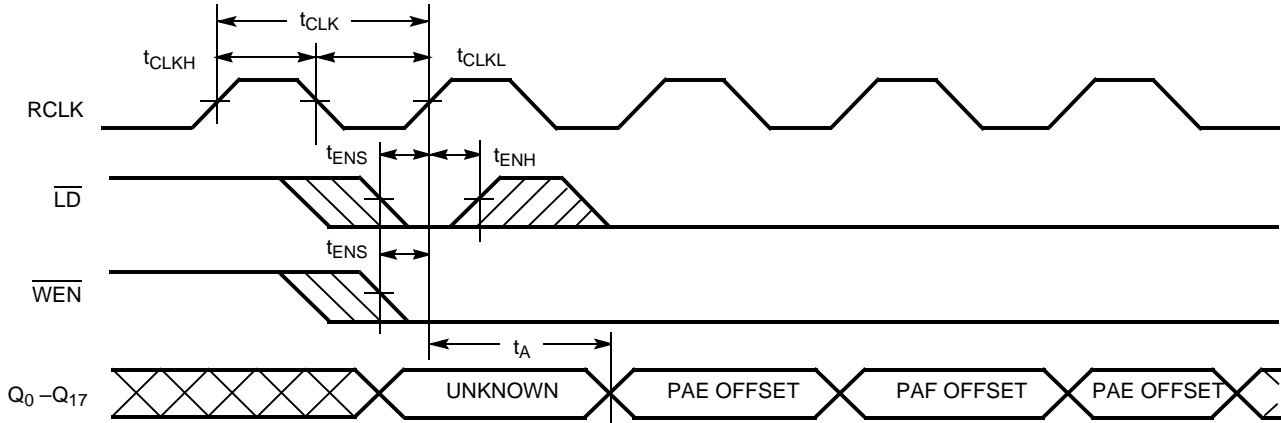

Figure 16. Write Expansion Out Timing

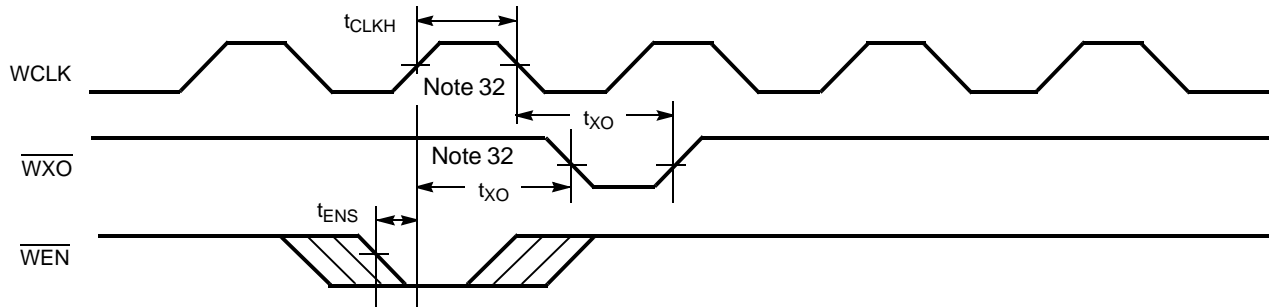

Figure 17. Read Expansion Out Timing

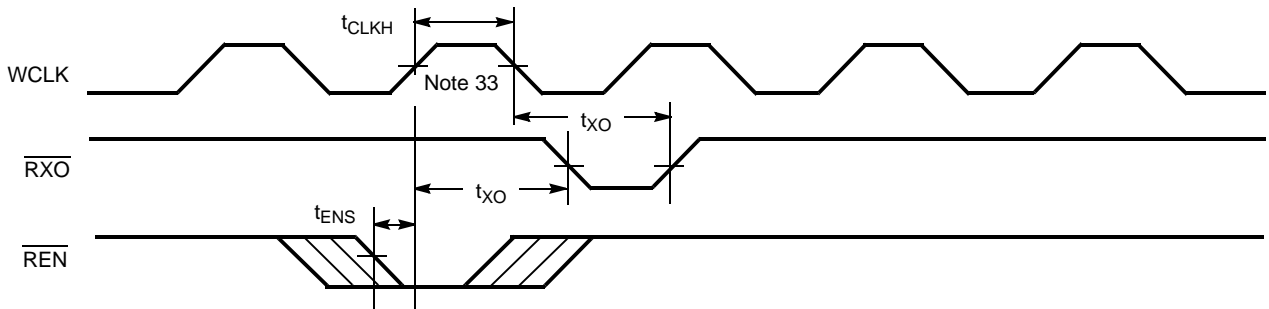
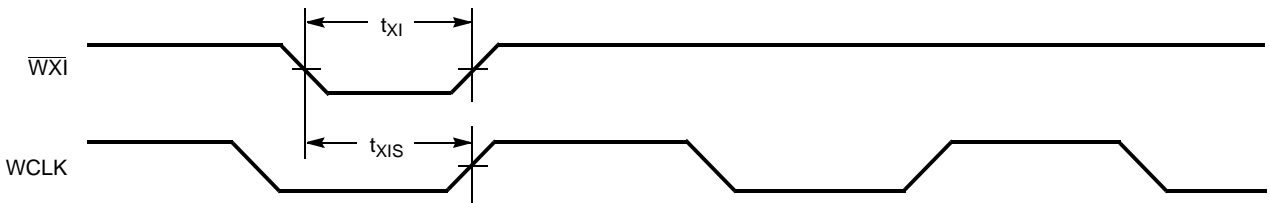

Figure 18. Write Expansion In Timing



Notes  
 32. Write to Last Physical Location.  
 33. Read from Last Physical Location.

Switching Waveforms (continued)

Figure 19. Read Expansion In Timing

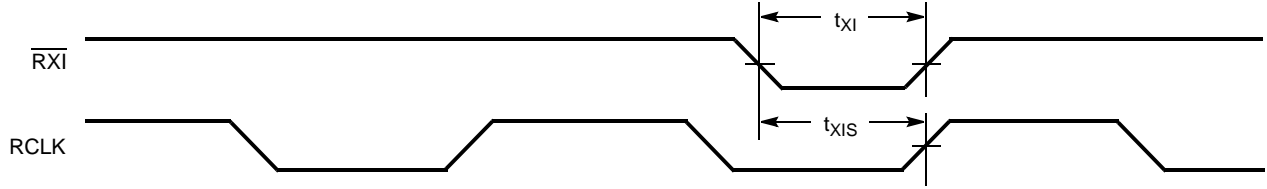
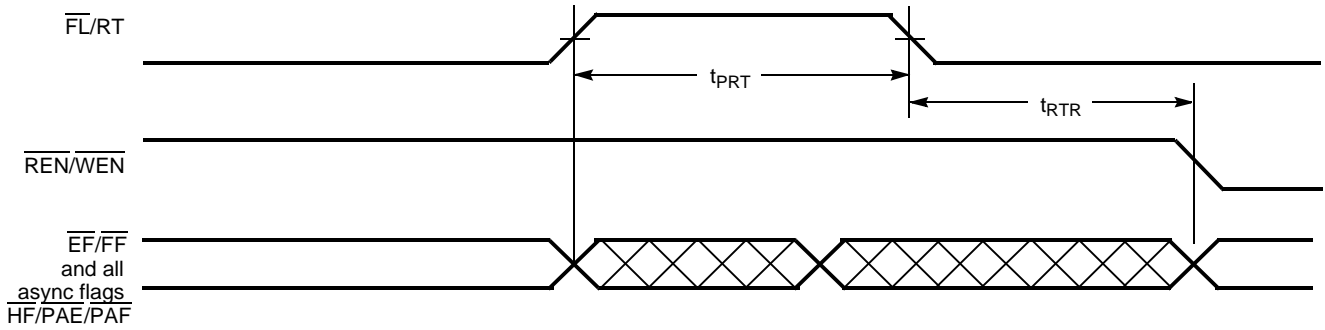

Figure 20. Retransmit Timing<sup>[34, 35, 36]</sup>



Notes

- 34. Clocks are free-running in this case.
- 35. The flags may change state during Retransmit as a result of the offset of the read and write pointers, but flags are valid at  $t_{RTR}$ .
- 36. For the synchronous PAE and PAF flags (SMODE), an appropriate clock cycle is necessary after  $t_{RTR}$  to update these flags.

## Architecture

The CY7C4256/65 consists of an array of 8K/16K words of 18 bits each (implemented by a dual-port array of SRAM cells), a read pointer, a write pointer, control signals (RCLK, WCLK, REN, WEN, RS), and flags (EF, PAE, HF, PAF, FF). The CY7C4265 also includes the control signals WXI, RXI, WXO, RXO for depth expansion.

## Resetting the FIFO

Upon power up, the FIFO must be reset with a Reset ( $\overline{RS}$ ) cycle. This causes the FIFO to enter the Empty condition signified by  $\overline{EF}$  being LOW. All data outputs go LOW after the falling edge of RS only if OE is asserted. For the FIFO to reset to its default state, a falling edge must occur on  $\overline{RS}$  and the user must not read or write while RS is LOW.

## FIFO Operation

When the  $\overline{WEN}$  signal is active (LOW), data present on the  $D_{0-17}$  pins is written into the FIFO on each rising edge of the WCLK signal. Similarly, when the REN signal is active LOW, data in the FIFO memory are presented on the  $Q_{0-17}$  outputs. New data is presented on each rising edge of RCLK while REN is active LOW and OE is LOW. REN must set up  $t_{ENS}$  before RCLK for it to be a valid read function. WEN must occur  $t_{ENS}$  before WCLK for it to be a valid write function.

An output enable ( $\overline{OE}$ ) pin is provided to three-state the  $Q_{0-17}$  outputs when OE is deasserted. When OE is enabled (LOW), data in the output register is available to the  $Q_{0-17}$  outputs after  $t_{OE}$ . If devices are cascaded, the OE function only outputs data on the FIFO that is read enabled.

The FIFO contains overflow circuitry to disallow additional writes when the FIFO is full, and under flow circuitry to disallow additional reads when the FIFO is empty. An empty FIFO maintains the data of the last valid read on its  $Q_{0-17}$  outputs even after additional reads occur.





## Programming

The CY7C4265 devices contain two 14-bit offset registers. Data present on  $D_{0-13}$  during a program write determines the distance from Empty (Full) that the Almost Empty (Almost Full) flags become active. If the user elects not to program the FIFO's flags, the default offset values are used (see Table 4). When the Load LD pin is set LOW and WEN is set LOW, data on the inputs  $D_{0-13}$  is written into the Empty offset register on the first LOW-to-HIGH transition of the Write Clock (WCLK). When the LD pin and WEN are held LOW then data is written into the Full offset register on the second LOW-to-HIGH transition of the Write Clock (WCLK). The third transition of the Write Clock (WCLK) again writes to the Empty offset register (see Table 4). Writing all offset registers does not have to occur at one time. One or two offset registers can be written and then, by bringing the LD pin HIGH, the FIFO is returned to normal read/write operation. When the LD pin is

set LOW, and  $\overline{WEN}$  is LOW, the next offset register in sequence is written.

The contents of the offset registers can be read on the output lines when the LD pin is set LOW and REN is set LOW; then, data can be read on the LOW-to-HIGH transition of the Read Clock (RCLK).

Table 4. Write Offset Register

LD	WEN	WCLK <sup>[37]</sup>	Selection
0	0		Writing to offset registers: Empty Offset Full Offset 
0	1		No Operation
1	0		Write Into FIFO
1	1		No Operation

## Flag Operation

The CY7C4265 devices provide five flag pins to indicate the condition of the FIFO contents. Empty and Full are synchronous. PAE and PAF are synchronous if  $V_{CC}/SMODE$  is tied to  $V_{SS}$ .

### Full Flag

The Full Flag ( $\overline{FF}$ ) goes LOW when device is Full. Write operations are inhibited whenever  $\overline{FF}$  is LOW regardless of the state of WEN.  $\overline{FF}$  is synchronized to WCLK: it is exclusively updated by each rising edge of WCLK.

### Empty Flag

The Empty Flag ( $\overline{EF}$ ) goes LOW when the device is empty. Read operations are inhibited whenever  $\overline{EF}$  is LOW, regardless of the state of REN.  $\overline{EF}$  is synchronized to RCLK, i.e., it is exclusively updated by each rising edge of RCLK.

### Programmable Almost Empty/Almost Full Flag

The CY7C4265 features programmable Almost Empty and Almost Full Flags. Each flag can be programmed (described in the Programming section) a specific distance from the corresponding boundary flags (Empty or Full). When the FIFO contains the number of words or fewer for which the flags have been programmed, the PAF or PAE are asserted, signifying that the FIFO is either Almost Full or Almost Empty. See Table 5 on page 17 for a description of programmable flags.

When the  $\overline{SMODE}$  pin is tied LOW, the  $\overline{PAF}$  flag signal transition is caused by the rising edge of the write clock and the PAE flag transition is caused by the rising edge of the read clock.

**Note**

37. The same selection sequence applies to reading from the registers.  $\overline{REN}$  is enabled and read is performed on the LOW-to-HIGH transition of RCLK.



## Retransmit

The retransmit feature is beneficial when transferring packets of data. It enables the receipt of data to be acknowledged by the receiver and retransmitted if necessary.

The Retransmit (RT) input is active in the stand-alone and width expansion modes. The retransmit feature is intended for use when a number of writes equal to or less than the depth of the FIFO have occurred and at least one word has been read since the last  $\overline{RS}$  cycle. A HIGH pulse on RT resets the internal read

pointer to the first physical location of the FIFO. WCLK and RCLK may be free running but must be disabled during and  $t_{RTR}$  after the retransmit pulse. With every valid read cycle after retransmit, previously accessed data is read and the read pointer is incremented until it is equal to the write pointer. Flags are governed by the relative locations of the read and write pointers and are updated during a retransmit cycle. Data written to the FIFO after activation of RT are transmitted also.

The full depth of the FIFO can be repeatedly retransmitted.

**Table 5. Flag Truth Table**

Number of Words in FIFO CY7C4265 – 16K x 18	$\overline{FF}$	$\overline{PAF}$	$\overline{HF}$	$\overline{PAE}$	$\overline{EF}$
0	H	H	H	L	L
1 to n <sup>[38]</sup>	H	H	H	L	H
(n + 1) to 8192	H	H	H	H	H
8193 to (16384 – (m + 1))	H	H	L	H	H
(16384 – m) <sup>[39]</sup> to 16383	H	L	L	H	H
16384	L	L	L	H	H

**Notes**

38. n = Empty Offset (Default Values: CY7C4265 n = 127).  
 39. m = Full Offset (Default Values: CY7C4265 n = 127).

### Width Expansion Configuration

The CY7C4265 can be expanded in width to provide word widths greater than 18 in increments of 18. During width expansion mode all control line inputs are common and all flags are available. Empty (Full) flags should be created by ANDing the Empty (Full) flags of every FIFO; the PAE and PAF flags can be detected from any one device. This technique avoids reading data from, or writing data to the FIFO that is "staggered" by one clock cycle due to the variations in skew between RCLK and WCLK. Figure 21 demonstrates a 36-word width by using two CY7C4265s.

Figure 21. Block Diagram of 8K x18/16K x 18 Synchronous FIFO Memory Used in a Width Expansion Configuration

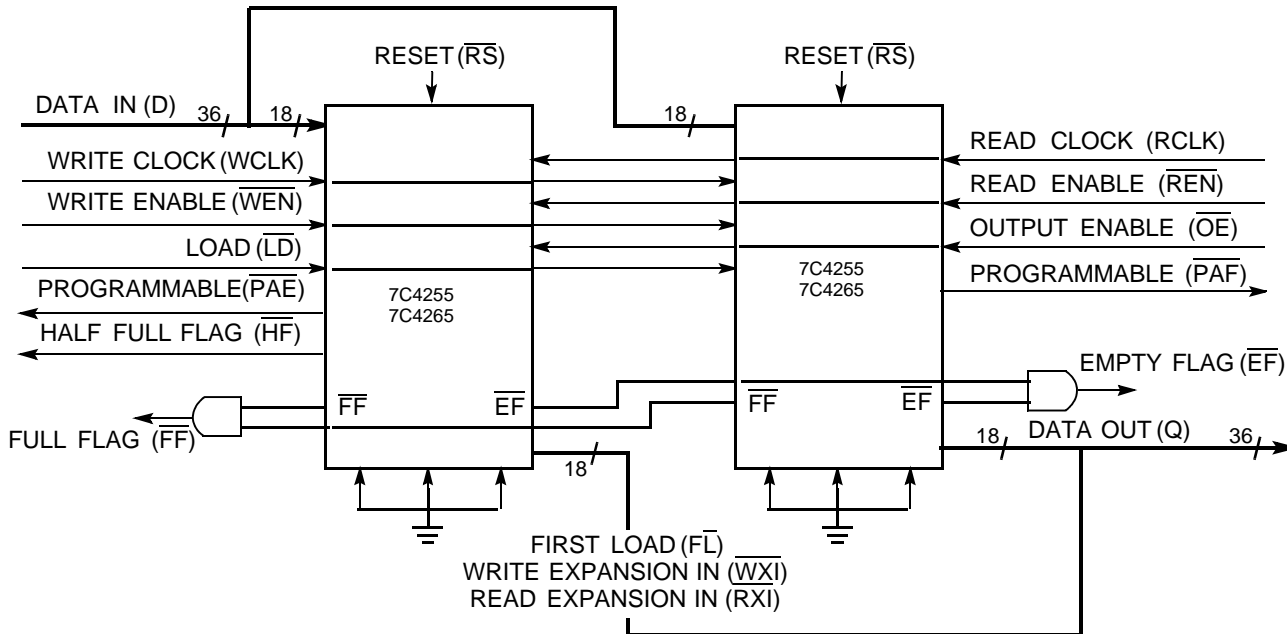

### Depth Expansion Configuration (with Programmable Flags)

The CY7C4265 can easily be adapted to applications requiring more than 8192/16384 words of buffering. Figure 22 shows Depth Expansion using three CY7C4265s. Maximum depth is limited only by signal loading. Follow these steps:

1. The first device must be designated by grounding the First Load (FL) control input.
2. All other devices must have FL in the HIGH state.
3. The Write Expansion Out (WXO) pin of each device must be tied to the Write Expansion In (WXI) pin of the next device.
4. The Read Expansion Out (RXO) pin of each device must be tied to the Read Expansion In (RXI) pin of the next device.
5. All Load (LD) pins are tied together.
6. The Half-Full Flag (HF) is not available in the Depth Expansion Configuration.
7. EF, FF, PAE, and PAF are created with composite flags by ORing together these respective flags for monitoring. The composite PAE and PAF flags are not precise.

Figure 22. Block Diagram of 8Kx18/16Kx18 Synchronous FIFO Memory with Programmable Flags used in Depth Expansion Configuration

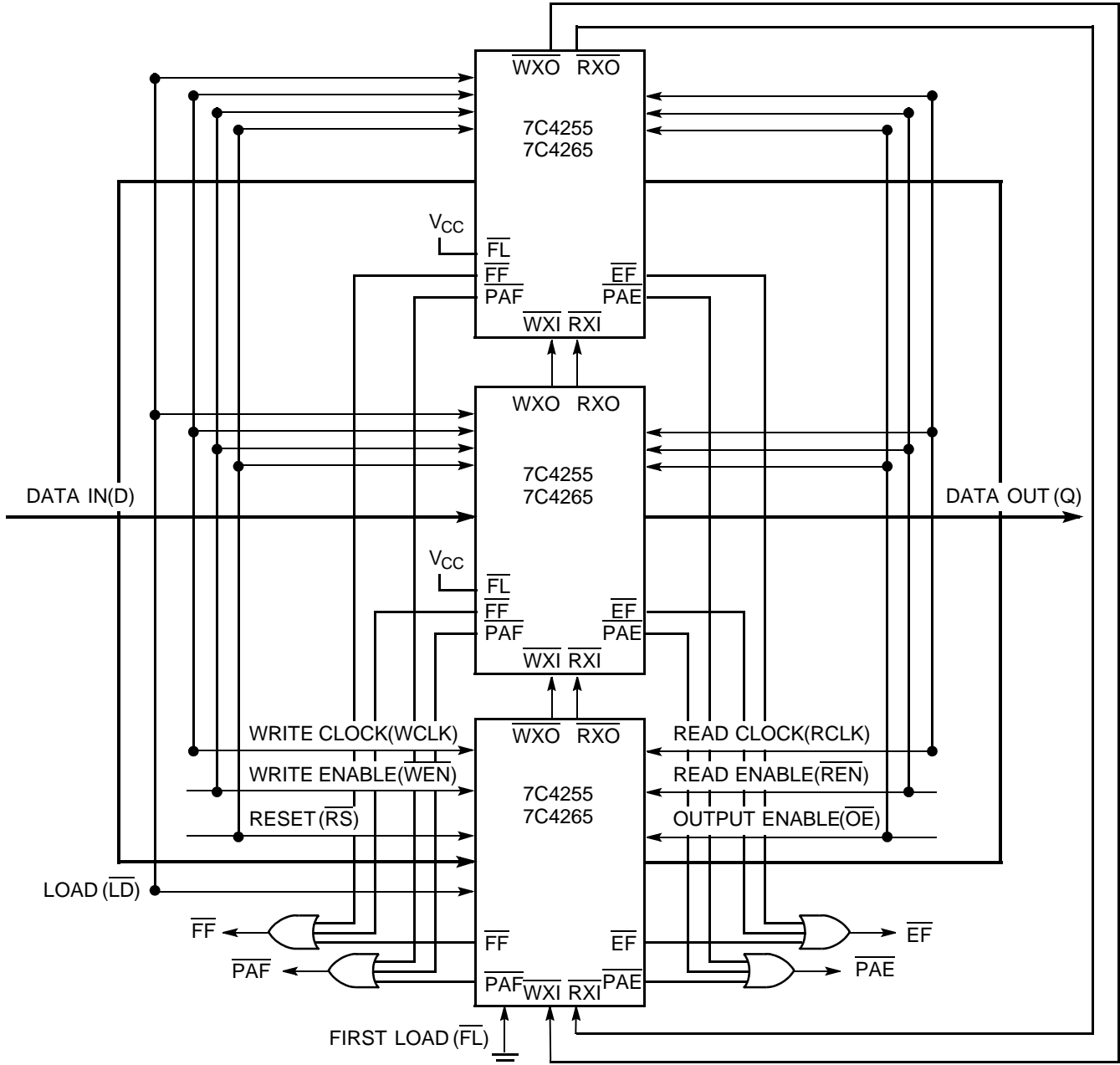
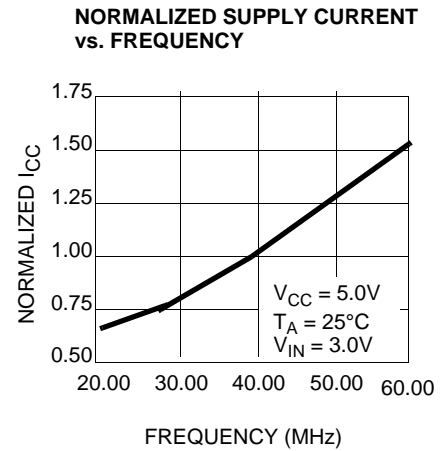
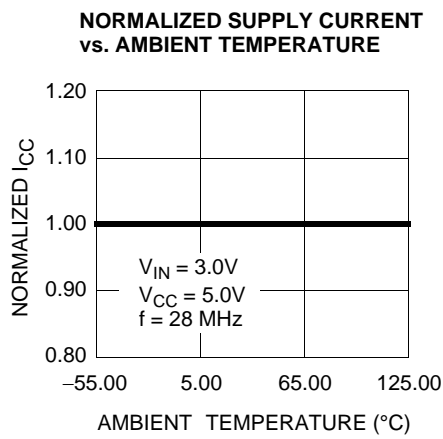
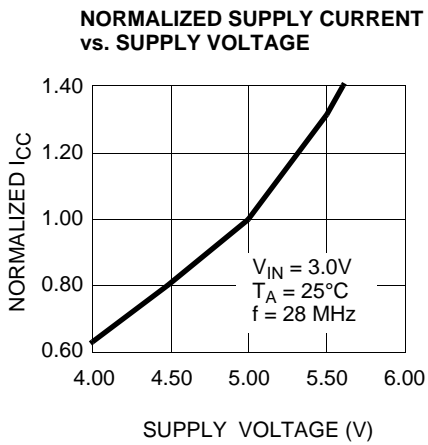
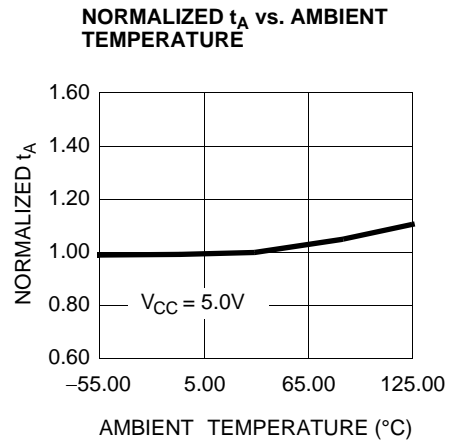
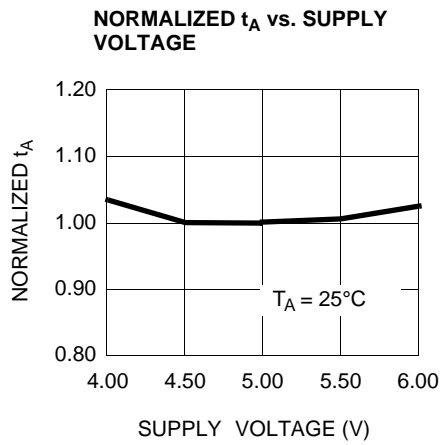

Figure 23. Typical AC and DC Characteristics



### Ordering Information

16 K x 18 Deep Sync FIFO				
Speed (ns)	Ordering Code	Package Diagram	Package Type	Operating Range
10	CY7C4265-10ASXC	51-85051	64-Pin Small Thin Quad Flatpack (Pb-free)	Commercial
	CY7C4265-10AI	51-85046	64-Pin Thin Quad Flatpack	Industrial
	CY7C4265-10AXI		64-Pin Thin Quad Flatpack (Pb-free)	
15	CY7C4265-15AXC	51-85046	64-Pin Thin Quad Flatpack (Pb-free)	Commercial

### Ordering Code Definitions

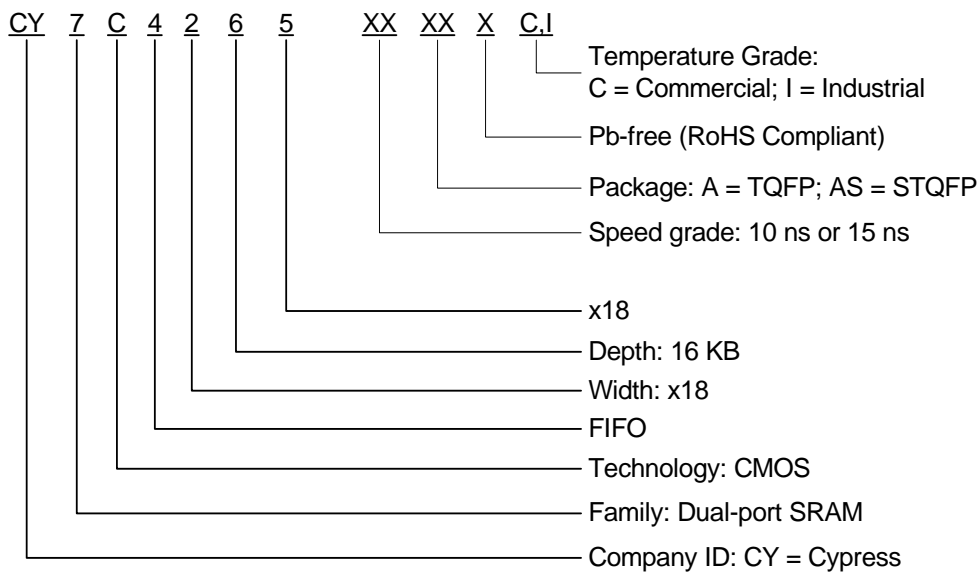

Package Diagrams

Figure 24. 64-Pin Thin Plastic Quad Flat Pack (10 x 10 x 1.4 mm), 51-85051

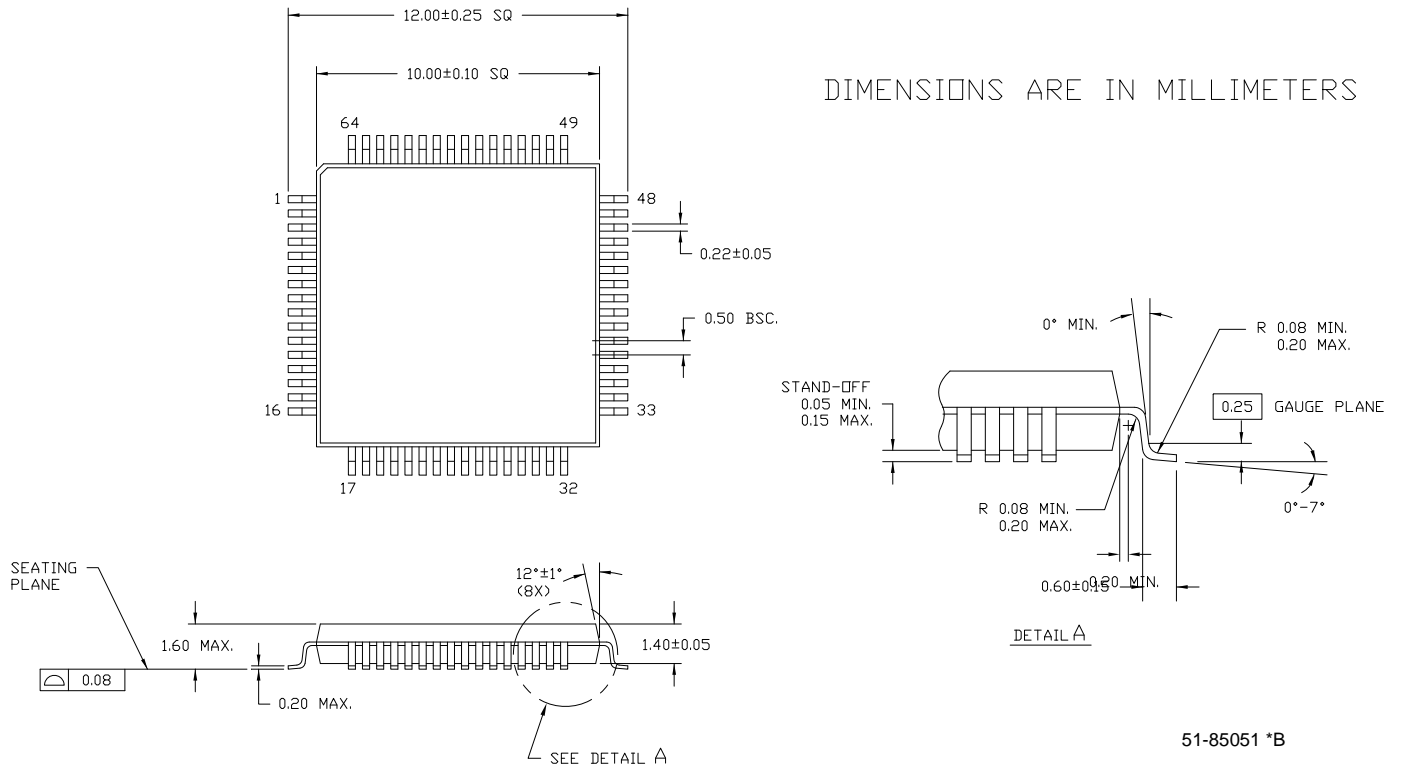
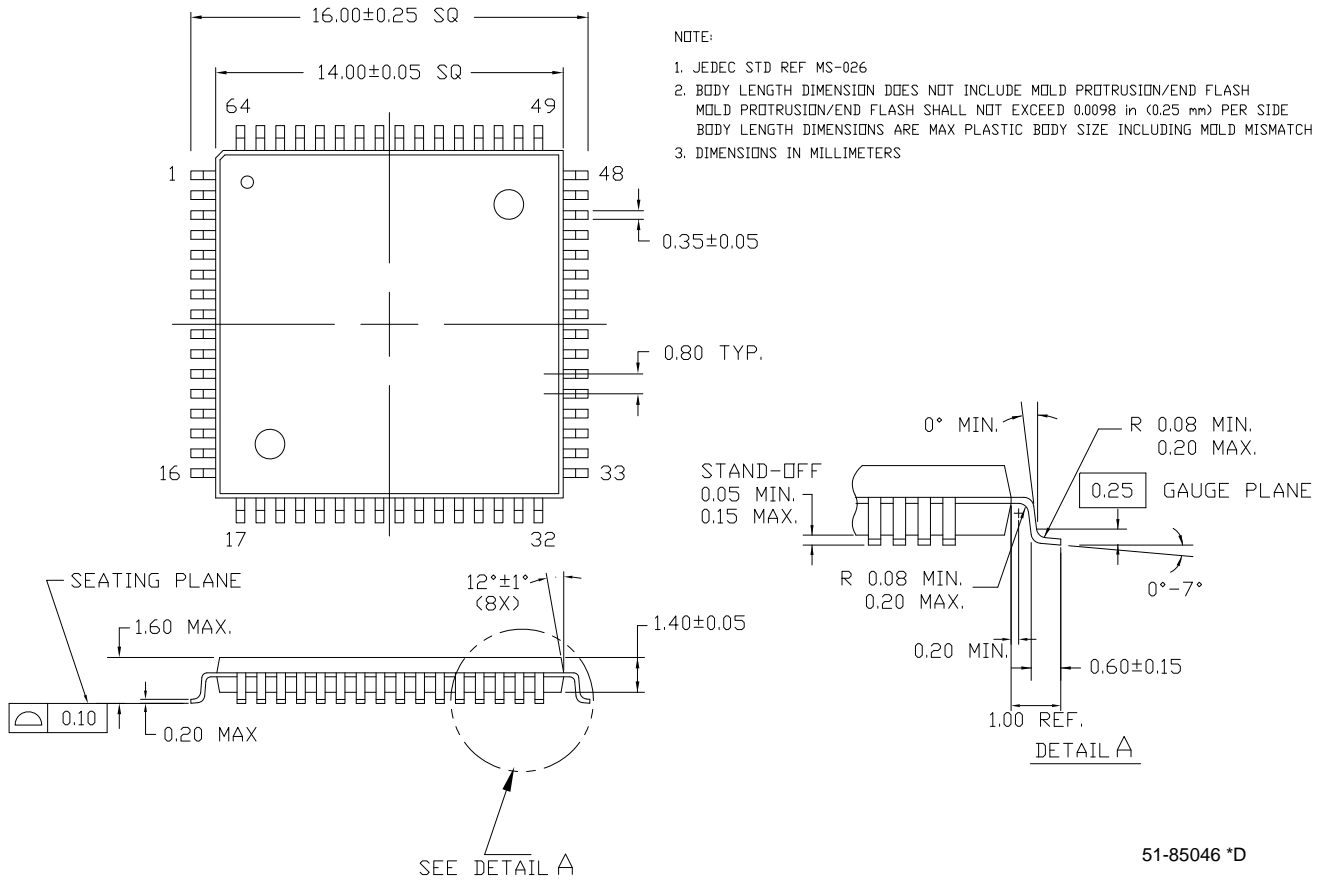

Figure 25. 64-Pin Thin Plastic Quad Flat Pack (14 x 14 x 1.4 mm), 51-85046



Document History Page

Document Title: CY7C4265 16 K x 18 Deep Sync FIFOs				
Document Number: 38-06004				
REV.	ECN NO.	Orig. of Change	Submission Date	Description of Change
**	106465	SZV	07/11/01	Change from Spec Number: 38-00468 to 38-06004
*A	122257	RBI	12/26/02	Power up requirements added to Maximum Ratings Information
*B	252889	YDT	See ECN	Removed PLCC package and pruned parts from Order Information
*C	385985	ESH	See ECN	Added Pb-Free logo to top of first page Added CY7C4265-10ASXC, CY7C4265-10AXI, CY7C4265-15AXC, CY7C4255-10AXC, CY7C4255-15AXC to ordering information
*D	2623658	VKN/PYRS	12/17/08	Added CY7C4265A part Updated Ordering information table
*E	2714768	VKN/AESA	06/04/09	Corrected defective Logic Block diagram, Pinouts, and Package diagrams
*F	2896039	RAME	03/19/10	Removed inactive parts from the data sheet. Updated title to CY7C4265 16K x 18 Deep Sync FIFOs
*G	3094385	ADMU	11/24/10	Sunset review spec. Included ordering code definitions.



## Sales, Solutions, and Legal Information

Cypress maintains a worldwide network of offices, solution centers, manufacturer's representatives, and distributors. To find the office closest to you, visit us at [Cypress Locations](#).

### Products

Automotive	<a href="http://cypress.com/go/automotive">cypress.com/go/automotive</a>
Clocks & Buffers	<a href="http://cypress.com/go/clocks">cypress.com/go/clocks</a>
Interface	<a href="http://cypress.com/go/interface">cypress.com/go/interface</a>
Lighting & Power Control	<a href="http://cypress.com/go/powerpsoc">cypress.com/go/powerpsoc</a> <a href="http://cypress.com/go/plc">cypress.com/go/plc</a>
Memory	<a href="http://cypress.com/go/memory">cypress.com/go/memory</a>
Optical & Image Sensing	<a href="http://cypress.com/go/image">cypress.com/go/image</a>
PSoC	<a href="http://cypress.com/go/psoc">cypress.com/go/psoc</a>
Touch Sensing	<a href="http://cypress.com/go/touch">cypress.com/go/touch</a>
USB Controllers	<a href="http://cypress.com/go/USB">cypress.com/go/USB</a>
Wireless/RF	<a href="http://cypress.com/go/wireless">cypress.com/go/wireless</a>

### PSoC Solutions

[psoc.cypress.com/solutions](http://psoc.cypress.com/solutions)  
PSoC 1 | PSoC 3 | PSoC 5

---

© Cypress Semiconductor Corporation, 2005-2010. The information contained herein is subject to change without notice. Cypress Semiconductor Corporation assumes no responsibility for the use of any circuitry other than circuitry embodied in a Cypress product. Nor does it convey or imply any license under patent or other rights. Cypress products are not warranted nor intended to be used for medical, life support, life saving, critical control or safety applications, unless pursuant to an express written agreement with Cypress. Furthermore, Cypress does not authorize its products for use as critical components in life-support systems where a malfunction or failure may reasonably be expected to result in significant injury to the user. The inclusion of Cypress products in life-support systems application implies that the manufacturer assumes all risk of such use and in doing so indemnifies Cypress against all charges.

Any Source Code (software and/or firmware) is owned by Cypress Semiconductor Corporation (Cypress) and is protected by and subject to worldwide patent protection (United States and foreign), United States copyright laws and international treaty provisions. Cypress hereby grants to licensee a personal, non-exclusive, non-transferable license to copy, use, modify, create derivative works of, and compile the Cypress Source Code and derivative works for the sole purpose of creating custom software and or firmware in support of licensee product to be used only in conjunction with a Cypress integrated circuit as specified in the applicable agreement. Any reproduction, modification, translation, compilation, or representation of this Source Code except as specified above is prohibited without the express written permission of Cypress.

Disclaimer: CYPRESS MAKES NO WARRANTY OF ANY KIND, EXPRESS OR IMPLIED, WITH REGARD TO THIS MATERIAL, INCLUDING, BUT NOT LIMITED TO, THE IMPLIED WARRANTIES OF MERCHANTABILITY AND FITNESS FOR A PARTICULAR PURPOSE. Cypress reserves the right to make changes without further notice to the materials described herein. Cypress does not assume any liability arising out of the application or use of any product or circuit described herein. Cypress does not authorize its products for use as critical components in life-support systems where a malfunction or failure may reasonably be expected to result in significant injury to the user. The inclusion of Cypress' product in a life-support systems application implies that the manufacturer assumes all risk of such use and in doing so indemnifies Cypress against all charges.

Use may be limited by and subject to the applicable Cypress software license agreement.