

74F779 8-Bit Bidirectional Binary Counter with 3-STATE Outputs

General Description

The 74F779 is a fully synchronous 8-stage up/down counter with multiplexed 3-STATE I/O ports for bus-oriented applications. All control functions (hold, count up, count down, synchronous load) are controlled by two mode pins (S_0 , S_1). The device also features carry lookahead for easy cascading. All state changes are initiated by the rising edge of the clock.

Features

- Multiplexed 3-STATE I/O ports
- Built-in lookahead carry capability
- Count frequency 100 MHz typ
- Supply current 80 mA typ
- Available in SOIC (300 mil only)

Ordering Code:

Order Number	Package Number	Package Description
74F779SC	M16B	16-Lead Small Outline Intergrated Circuit (SOIC), JEDEC MS-013, 0.300" Wide
74F779PC	N16E	16-Lead Plastic Dual-In-Line Package (PDIP), JEDEC MS-001, 0.300" Wide

Logic Symbol

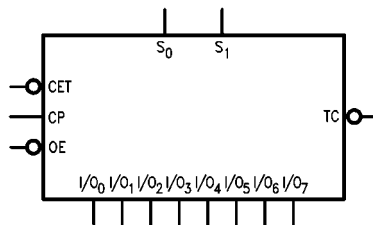

Connection Diagram

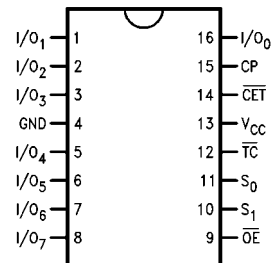

Unit Loading/Fan Out

Pin Names	Description	U.L.	
		HIGH/LOW	Input I_{IH}/I_{IL} Output I_{OH}/I_{OL}
I/O_0 – I/O_7	Data Inputs	0.25/0.33	5 μ A/–0.2 mA
	Data Outputs	75/15 (12.5)	–3 mA/24 mA (20 mA)
S_0, S_1	Select Inputs	0.25/0.33	5 μ A/–0.2 mA
\overline{OE}	Output Enable Input (Active LOW)	0.25/0.33	5 μ A/–0.2 mA
\overline{CET}	Count Enable Trickle Input (Active LOW)	0.25/0.33	5 μ A/–0.2 mA
CP	Clock Pulse Input (Active Rising Edge)	0.25/0.33	5 μ A/–0.2 mA
\overline{TC}	Terminal Count Output (Active LOW)	25/12.5	–1 mA/20 mA

Function Table

S_1	S_0	\overline{CET}	\overline{OE}	CP	Function
X	X	X	H	X	I/O_0 to I/O_7 in High Z
X	X	X	L	X	Flip-Flop Outputs Appear on I/O Lines
L	L	X	H	↗	Parallel Load All Flip-Flops
(Not LL)		H	X	↗	Hold (\overline{TC} Held HIGH)
H	L	L	X	↗	Count Up
L	H	L	X	↗	Count Down

H = HIGH Voltage Level

L = LOW Voltage Level

X = Immaterial

↗ = LOW-to-HIGH Clock Transition

(Not LL) means S_0 and S_1 should never both be LOW level at the same time.

Logic Diagram

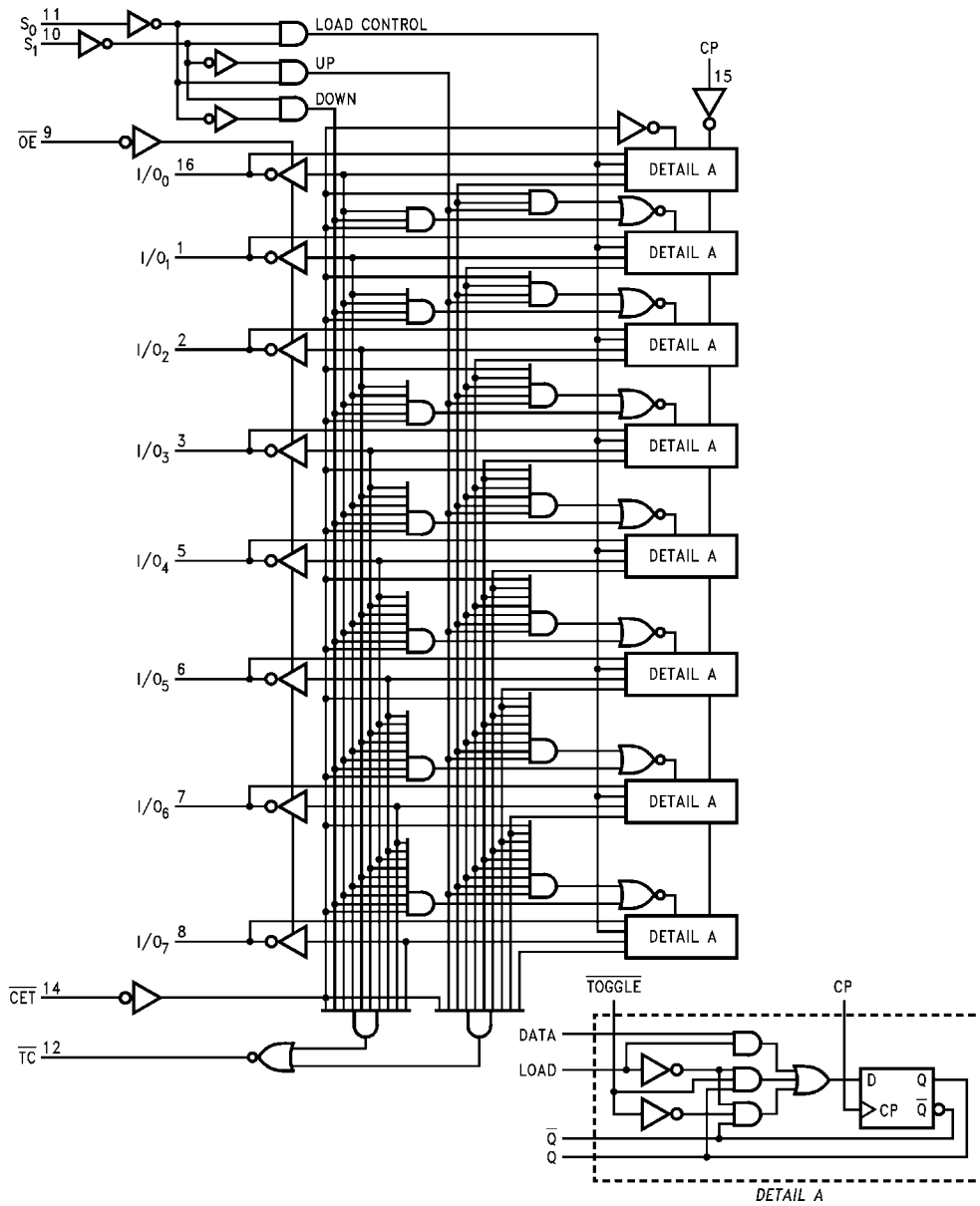

Please note that this diagram is provided only for the understanding of logic operations and should not be used to estimate propagation delays.

Absolute Maximum Ratings (Note 1)

Storage Temperature	-65°C to +150°C
Ambient Temperature under Bias	-55°C to +125°C
Junction Temperature under Bias	-55°C to +150°C
V _{CC} Pin Potential to Ground Pin	-0.5V to +7.0V
Input Voltage (Note 2)	-0.5V to +7.0V
Input Current (Note 2)	-30 mA to +5.0 mA
Voltage Applied to Output in HIGH State (with V _{CC} = 0V)	
Standard Output	-0.5V to V _{CC}
3-STATE Output	-0.5V to +5.5V
Current Applied to Output in LOW State (Max)	twice the rated I _{OL} (mA)
ESD Last Passing Voltage (Min)	4000V

Recommended Operating Conditions

Free Air Ambient Temperature	0°C to +70°C
Supply Voltage	+4.5V to +5.5V

Note 1: Absolute maximum ratings are values beyond which the device may be damaged or have its useful life impaired. Functional operation under these conditions is not implied.

Note 2: Either voltage limit or current limit is sufficient to protect inputs.

DC Electrical Characteristics

Symbol	Parameter	Min	Typ	Max	Units	V _{CC}	Conditions
V _{IH}	Input HIGH Voltage	2.0			V		Recognized as a HIGH Signal
V _{IL}	Input LOW Voltage			0.8	V		Recognized as a LOW Signal
V _{CD}	Input Clamp Diode Voltage			-1.2	V	Min	I _{IN} = -18 mA
V _{OH}	Output HIGH Voltage	10% V _{CC} 5% V _{CC}	2.4 2.7		V	Min	I _{OH} = -3 mA
V _{OL}	Output LOW Voltage	10% V _{CC} 5% V _{CC}		0.5 0.5	V	Min	I _{OL} = 20 mA I _{OL} = 20 mA
I _{IH}	Input HIGH Current			5.0	μA	Max	V _{IN} = 2.7V (Non-I/O Pins)
I _{BVI}	Input HIGH Current Breakdown Test			7.0	μA	Max	V _{IN} = 7.0V (Non-I/O Pins)
I _{BVIT}	Input HIGH Current Breakdown (I/O)			0.5	mA	Max	V _{IN} = 5.5V (I/O _n)
I _{CEX}	Output HIGH Leakage Current			50	μA	Max	V _{OUT} = V _{CC}
V _{ID}	Input Leakage Test	4.75			V	0.0	I _{ID} = 1.9 μA All other pins grounded
I _{OD}	Output Leakage Circuit Current			3.75	μA	0.0	V _{IOD} = 150 mV All other pins grounded
I _{ZZ}	Bus Drainage Test		500		μA	0.0	V _{OUT} = 5.25V
I _{IL}	Input LOW Current			-0.2	mA	Max	V _{IN} = 0.5V (Non I/O Pins)
I _{IH} + I _{OZH}	Output Leakage Current			70	μA	Max	V _{OUT} = 2.7V (I/O _n)
I _{IL} + I _{OZL}	Output Leakage Current			-200	μA	Max	V _{OUT} = 0.5V (I/O _n)
I _{OS}	Output Short-Circuit Current	-60		-150	mA	Max	V _{OUT} = 0V
I _{CCH}	Power Supply Current			90	mA	Max	V _O = HIGH
I _{CCL}	Power Supply Current			105	mA	Max	V _O = LOW
I _{CCZ}	Power Supply Current			110	mA	Max	V _O = HIGH Z

AC Electrical Characteristics							
Symbol	Parameter	T _A = +25°C V _{CC} = +5.0V C _L = 50 pF			T _A = 0°C to +70°C V _{CC} = +5.0V C _L = 50 pF		Units
		Min	Typ	Max	Min	Max	
f _{MAX}	Maximum Clock Frequency	100	105		90		
t _{PLH}	Propagation Delay	3.0	5.0	8.0	3.0	8.5	ns
t _{PHL}	CP to I/O _n	5.0	7.5	11.0	5.0	11.0	
t _{PLH}	Propagation Delay	5.0	7.5	9.0	5.0	10.0	ns
t _{PHL}	CP to \overline{TC}	5.0	9.3	10.5	5.0	11.5	
t _{PLH}	Propagation Delay	2.5	3.8	5.5	2.5	6.0	ns
t _{PHL}	\overline{CET} to \overline{TC}	4.5	6.1	8.0	4.5	8.5	
t _{PLH}	Propagation Delay	3.5	6.5	12.0	3.5	13.0	ns
t _{PHL}	SN to \overline{TC}	3.5	7.5	12.0	3.5	13.0	
t _{PZH}	Output Enable Time	3.0	5.0	7.0	3.0	8.0	ns
t _{PZL}	\overline{OE} to I/O _n	5.0	8.0	10.0	5.0	10.5	
t _{PHZ}	Output Disable Time	1.0	4.0	6.5	1.0	7.0	ns
t _{PLZ}	\overline{OE} to I/O _n	1.0	3.7	6.5	1.0	7.0	

AC Operating Requirements						
Symbol	Parameter	T _A = +25°C V _{CC} = +5.0V		T _A = 0°C to +70°C V _{CC} = +5.0V		Units
		Min	Max	Min	Max	
t _S (H)	Setup Time	5.0		5.0		ns
t _S (L)	I/O _n to CP	5.0		5.0		
t _H (H)	Hold Time	0.0		0.0		ns
t _H (L)	I/O _n to CP	0.0		0.0		
t _S (H)	Setup Time	9.5		10.0		ns
t _S (L)	S _n to CP	9.5		10.0		
t _H (H)	Hold Time	0.0		0.0		ns
t _H (L)	S _n to CP	0.0		0.0		
t _S (H)	Setup Time	7.0		7.0		ns
t _S (L)	\overline{CET} to CP	7.0		7.0		
t _H (H)	Hold Time	0.0		0.0		ns
t _H (L)	\overline{CET} to CP	0.0		0.0		
t _W (H)	Clock Pulse Width	4.0		4.0		ns
t _W (L)	HIGH or LOW	4.0		4.0		

74F779

Physical Dimensions inches (millimeters) unless otherwise noted

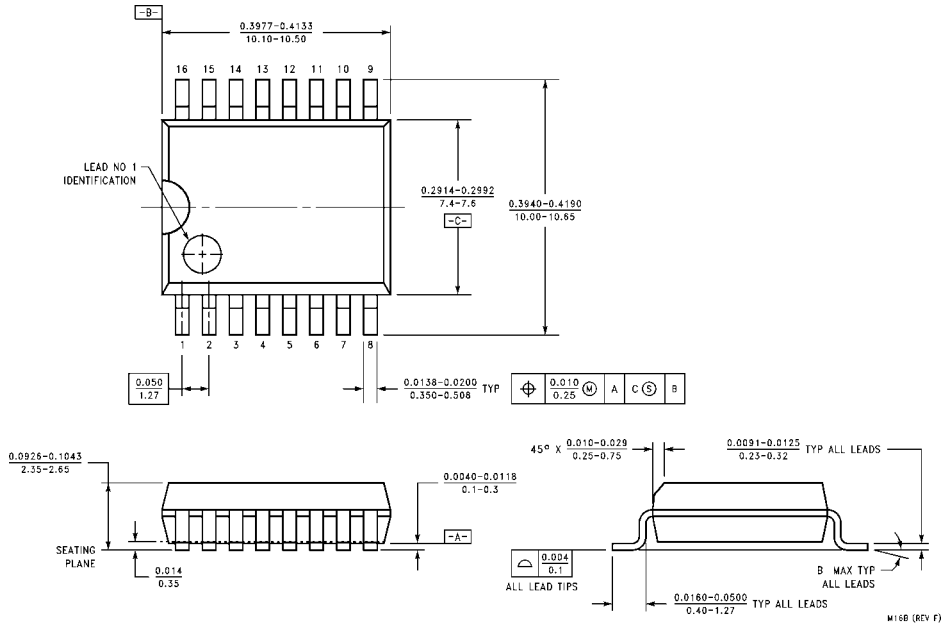

**16-Lead Small Outline Intergrated Circuit (SOIC), JEDEC MS-013, 0.300" Wide
Package Number M16B**

Physical Dimensions inches (millimeters) unless otherwise noted (Continued)

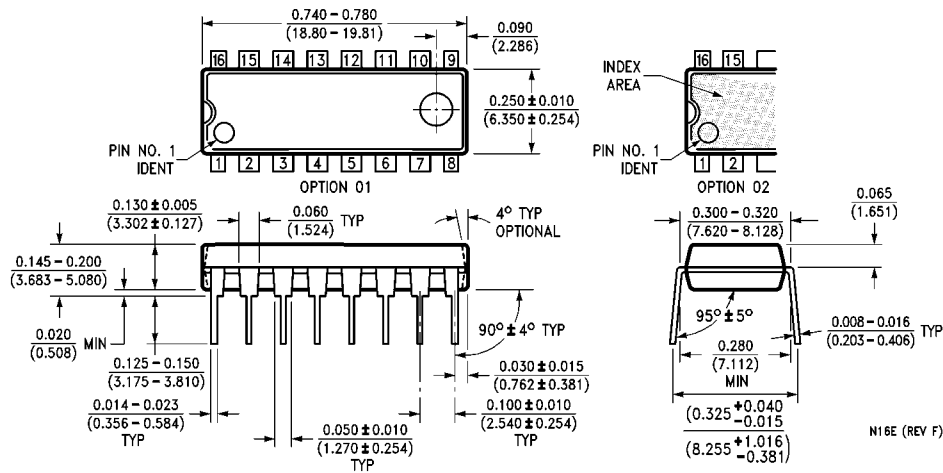

16-Lead Plastic Dual-In-Line Package (PDIP), JEDEC MS-001, 0.300" Wide Package Number N16E

Fairchild does not assume any responsibility for use of any circuitry described, no circuit patent licenses are implied and Fairchild reserves the right at any time without notice to change said circuitry and specifications.

LIFE SUPPORT POLICY

FAIRCHILD'S PRODUCTS ARE NOT AUTHORIZED FOR USE AS CRITICAL COMPONENTS IN LIFE SUPPORT DEVICES OR SYSTEMS WITHOUT THE EXPRESS WRITTEN APPROVAL OF THE PRESIDENT OF FAIRCHILD SEMICONDUCTOR CORPORATION. As used herein:

1. Life support devices or systems are devices or systems which, (a) are intended for surgical implant into the body, or (b) support or sustain life, and (c) whose failure to perform when properly used in accordance with instructions for use provided in the labeling, can be reasonably expected to result in a significant injury to the user.
2. A critical component in any component of a life support device or system whose failure to perform can be reasonably expected to cause the failure of the life support device or system, or to affect its safety or effectiveness.

www.fairchildsemi.com