

MC14521B

24-Stage Frequency Divider

The MC14521B consists of a chain of 24 flip-flops with an input circuit that allows three modes of operation. The input will function as a crystal oscillator, an RC oscillator, or as an input buffer for an external oscillator. Each flip-flop divides the frequency of the previous flip-flop by two, consequently this part will count up to $2^{24} = 16,777,216$. The count advances on the negative going edge of the clock. The outputs of the last seven-stages are available for added flexibility.

Features

- All Stages are Resettable
- Reset Disables the RC Oscillator for Low Standby Power Drain
- RC and Crystal Oscillator Outputs Are Capable of Driving External Loads
- Test Mode to Reduce Test Time
- V_{DD}' and V_{SS}' Pins Brought Out on Crystal Oscillator Inverter to Allow the Connection of External Resistors for Low-Power Operation
- Supply Voltage Range = 3.0 Vdc to 18 Vdc
- Capable of Driving Two Low-Power TTL Loads or One Low-Power Schottky TTL Load over the Rated Temperature Range
- These are Pb-Free Devices*

MAXIMUM RATINGS (Voltages Referenced to V_{SS})

Parameter	Symbol	Value	Unit
DC Supply Voltage Range	V_{DD}	-0.5 to +18.0	V
Input or Output Voltage Range (DC or Transient)	V_{in}, V_{out}	-0.5 to V_{DD} +0.5	V
Input or Output Current (DC or Transient) per Pin	I_{in}, I_{out}	± 10	mA
Power Dissipation, per Package (Note 1)	P_D	500	mW
Ambient Temperature Range	T_A	-55 to +125	$^{\circ}\text{C}$
Storage Temperature Range	T_{stg}	-65 to +150	$^{\circ}\text{C}$
Lead Temperature (8-Second Soldering)	T_L	260	$^{\circ}\text{C}$

Stresses exceeding Maximum Ratings may damage the device. Maximum Ratings are stress ratings only. Functional operation above the Recommended Operating Conditions is not implied. Extended exposure to stresses above the Recommended Operating Conditions may affect device reliability.

1. Temperature Derating: Plastic "P and D/DW"
 Packages: - 7.0 mW/ $^{\circ}\text{C}$ From 65 $^{\circ}\text{C}$ To 125 $^{\circ}\text{C}$

This device contains protection circuitry to guard against damage due to high static voltages or electric fields. However, precautions must be taken to avoid applications of any voltage higher than maximum rated voltages to this high-impedance circuit. For proper operation, V_{in} and V_{out} should be constrained to the range $V_{SS} \leq (V_{in} \text{ or } V_{out}) \leq V_{DD}$.

Unused inputs must always be tied to an appropriate logic voltage level (e.g., either V_{SS} or V_{DD}). Unused outputs must be left open.

*For additional information on our Pb-Free strategy and soldering details, please download the ON Semiconductor Soldering and Mounting Techniques Reference Manual, SOLDERRM/D.



ON Semiconductor®

<http://onsemi.com>

MARKING DIAGRAMS

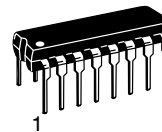

PDIP-16
P SUFFIX
CASE 648

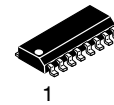
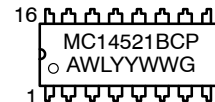

SOIC-16
D SUFFIX
CASE 751B

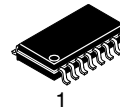
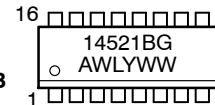

SOEIAJ-16
F SUFFIX
CASE 966



A = Assembly Location
 WL, L = Wafer Lot
 YY, Y = Year
 WW, W = Work Week
 G = Pb-Free Package

ORDERING INFORMATION

See detailed ordering and shipping information in the package dimensions section on page 2 of this data sheet.

MC14521B

BLOCK DIAGRAM

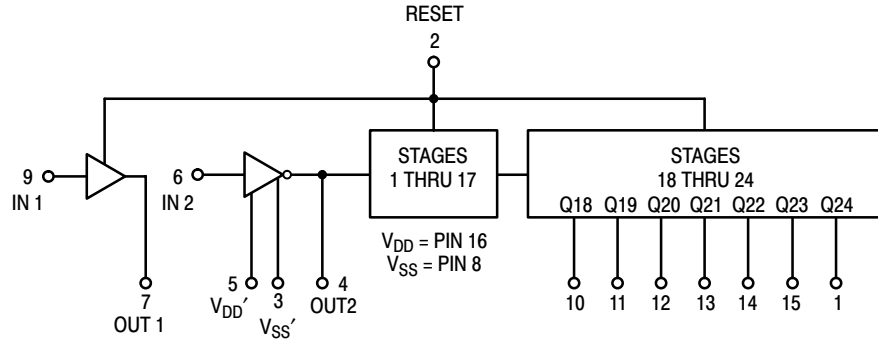

PIN ASSIGNMENT

Q24	1	16	V _{DD}
RESET	2	15	Q23
V _{SS} '	3	14	Q22
OUT 2	4	13	Q21
V _{DD} '	5	12	Q20
IN 2	6	11	Q19
OUT 1	7	10	Q18
V _{SS}	8	9	IN 1

Output	Count Capacity
Q18	2 ¹⁸ = 262,144
Q19	2 ¹⁹ = 524,288
Q20	2 ²⁰ = 1,048,576
Q21	2 ²¹ = 2,097,152
Q22	2 ²² = 4,194,304
Q23	2 ²³ = 8,388,608
Q24	2 ²⁴ = 16,777,216

ORDERING INFORMATION

Device	Package	Shipping†
MC14521BCPG	PDIP-16 (Pb-Free)	25 Units / Rail
MC14521BDG	SOIC-16 (Pb-Free)	48 Units / Rail
MC14521BDR2G	SOIC-16 (Pb-Free)	2500 / Tape & Reel
MC14521BFG	SOEIAJ-16 (Pb-Free)	50 Units / Rail
MC14521BFELG	SOEIAJ-16 (Pb-Free)	2000 / Tape & Reel

†For information on tape and reel specifications, including part orientation and tape sizes, please refer to our Tape and Reel Packaging Specifications Brochure, BRD8011/D.

MC14521B

ELECTRICAL CHARACTERISTICS (Voltages Referenced to V_{SS})

Characteristic	Symbol	V _{DD} Vdc	- 55° C		25° C			125° C		Unit	
			Min	Max	Min	Typ (Note 2)	Max	Min	Max		
Output Voltage V _{in} = V _{DD} or 0 V _{in} = 0 or V _{DD}	V _{OL}	5.0	-	0.05	-	0	0.05	-	0.05	Vdc	
		10	-	0.05	-	0	0.05	-	0.05		
15		-	0.05	-	0	0.05	-	0.05			
	V _{OH}	5.0	4.95	-	4.95	5.0	-	4.95	-	Vdc	
		10	9.95	-	9.95	10	-	9.95	-		
		15	14.95	-	14.95	15	-	14.95	-		
Input Voltage (V _O = 4.5 or 0.5 Vdc) (V _O = 9.0 or 1.0 Vdc) (V _O = 13.5 or 1.5 Vdc)	V _{IL}	5.0	-	1.5	-	2.25	1.5	-	1.5	Vdc	
		10	-	3.0	-	4.50	3.0	-	3.0		
15		-	4.0	-	6.75	4.0	-	4.0			
(V _O = 0.5 or 4.5 Vdc) (V _O = 1.0 or 9.0 Vdc) (V _O = 1.5 or 13.5 Vdc)	V _{IH}	5.0	3.5	-	3.5	2.75	-	3.5	-	Vdc	
		10	7.0	-	7.0	5.50	-	7.0	-		
		15	11	-	11	8.25	-	11	-		
Output Drive Current (V _{OH} = 4.5 Vdc) Source (V _{OH} = 9.0 Vdc) Pin 4 (V _{OH} = 13 Vdc) (V _{OH} = 2.5 Vdc) Source (V _{OH} = 4.6 Vdc) Pins 1, 7, 10, (V _{OH} = 9.5 Vdc) 11, 12, 13, 14 (V _{OH} = 13.5 Vdc) and 15 (V _{OL} = 0.4 Vdc) Sink (V _{OL} = 0.5 Vdc) (V _{OL} = 1.5 Vdc)	I _{OH}	5.0	-0.25	-	-0.2	-0.36	-	-0.14	-	mAdc	
		10	-0.62	-	-0.5	-0.9	-	-0.35	-		
		15	-1.8	-	-1.5	-3.5	-	-1.1	-		
			5.0	-3.0	-	-2.4	-4.2	-	-1.7	-	mAdc
			5.0	-0.64	-	-0.51	-0.88	-	-0.36	-	
			10	-1.6	-	-1.3	-2.25	-	-0.9	-	
15	-4.2	-	-3.4	-8.8	-	-2.4	-				
	I _{OL}	5.0	0.64	-	0.51	0.88	-	0.36	-	mAdc	
		10	1.6	-	1.3	2.25	-	0.9	-		
		15	4.2	-	3.4	8.8	-	2.4	-		
Input Current	I _{in}	15	-	±0.1	-	±0.00001	±0.1	-	±1.0	μAdc	
Input Capacitance (V _{in} = 0)	C _{in}	-	-	-	-	5.0	7.5	-	-	pF	
Quiescent Current (Per Package)	I _{DD}	5.0	-	5.0	-	0.005	5.0	-	150	μAdc	
		10	-	10	-	0.010	10	-	300		
		15	-	20	-	0.015	20	-	600		
Total Supply Current (Note 3, 4) (Dynamic plus Quiescent, Per Package) (C _L = 50 pF on all outputs, all buffers switching)	I _T	5.0 10 15	I _T = (0.42 μA/kHz) f + I _{DD} I _T = (0.85 μA/kHz) f + I _{DD} I _T = (1.40 μA/kHz) f + I _{DD}						μAdc		

2. Data labelled "Typ" is not to be used for design purposes but is intended as an indication of the IC's potential performance.

3. The formulas given are for the typical characteristics only at 25°C.

4. To calculate total supply current at loads other than 50 pF: I_T(C_L) = I_T(50 pF) + (C_L - 50) Vfk where: I_T is in μA (per package), C_L in pF, V = (V_{DD} - V_{SS}) in volts, f in kHz is input frequency, and k = 0.003.

MC14521B

SWITCHING CHARACTERISTICS (Note 5) ($C_L = 50 \text{ pF}$, $T_A = 25^\circ\text{C}$)

Characteristic	Symbol	V_{DD} Vdc	Min	Typ (Note 6)	Max	Unit
Output Rise and Fall Time (Counter Outputs) $t_{TLH}, t_{THL} = (1.5 \text{ ns/pF}) C_L + 25 \text{ ns}$ $t_{TLH}, t_{THL} = (0.75 \text{ ns/pF}) C_L + 12.5 \text{ ns}$ $t_{TLH}, t_{THL} = (0.55 \text{ ns/pF}) C_L + 12.5 \text{ ns}$	t_{TLH}, t_{THL}	5.0 10 15	- - -	100 50 40	200 100 80	ns
Propagation Delay Time Clock to Q18 $t_{PHL}, t_{PLH} = (1.7 \text{ ns/pF}) C_L + 4415 \text{ ns}$ $t_{PHL}, t_{PLH} = (0.66 \text{ ns/pF}) C_L + 1667 \text{ ns}$ $t_{PHL}, t_{PLH} = (0.5 \text{ ns/pF}) C_L + 1275 \text{ ns}$ Clock to Q24 $t_{PHL}, t_{PLH} = (1.7 \text{ ns/pF}) C_L + 5915 \text{ ns}$ $t_{PHL}, t_{PLH} = (0.66 \text{ ns/pF}) C_L + 2167 \text{ ns}$ $t_{PHL}, t_{PLH} = (0.5 \text{ ns/pF}) C_L + 1675 \text{ ns}$	t_{PHL}, t_{PLH}	5.0 10 15 5.0 10 15	- - - - - -	4.5 1.7 1.3 6.0 2.2 1.7	9.0 3.5 2.7 12 4.5 3.5	μs
Propagation Delay Time Reset to Q_n $t_{PHL} = (1.7 \text{ ns/pF}) C_L + 1215 \text{ ns}$ $t_{PHL} = (0.66 \text{ ns/pF}) C_L + 467 \text{ ns}$ $t_{PHL} = (0.5 \text{ ns/pF}) C_L + 350 \text{ ns}$	t_{PHL}	5.0 10 15	- - -	1300 500 375	2600 1000 750	ns
Clock Pulse Width	$t_{WH(cl)}$	5.0 10 15	385 150 120	140 55 40	- - -	ns
Clock Pulse Frequency	f_{cl}	5.0 10 15	- - -	3.5 9.0 12	2.0 5.0 6.5	MHz
Clock Rise and Fall Time	t_{TLH}, t_{THL}	5.0 10 15	- - -	- - -	15 5.0 4.0	μs
Reset Pulse Width	$t_{WH(R)}$	5.0 10 15	1400 600 450	700 300 225	- - -	ns
Reset Removal Time	t_{rem}	5.0 10 15	30 0 -40	-200 -160 -110	- - -	ns

5. The formulas given are for the typical characteristics only at 25°C .

6. Data labelled "Typ" is not to be used for design purposes but is intended as an indication of the IC's potential performance.

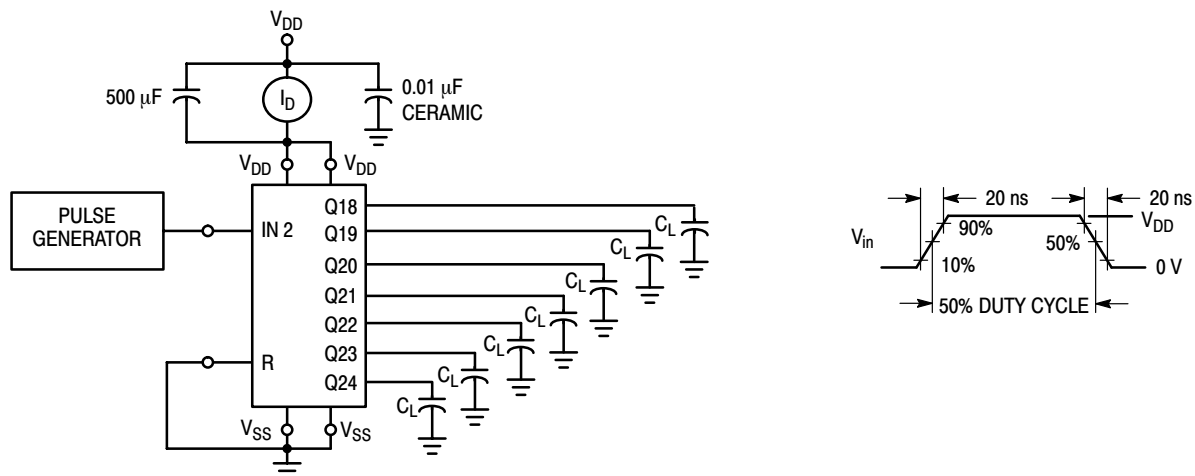

Figure 1. Power Dissipation Test Circuit and Waveform

MC14521B

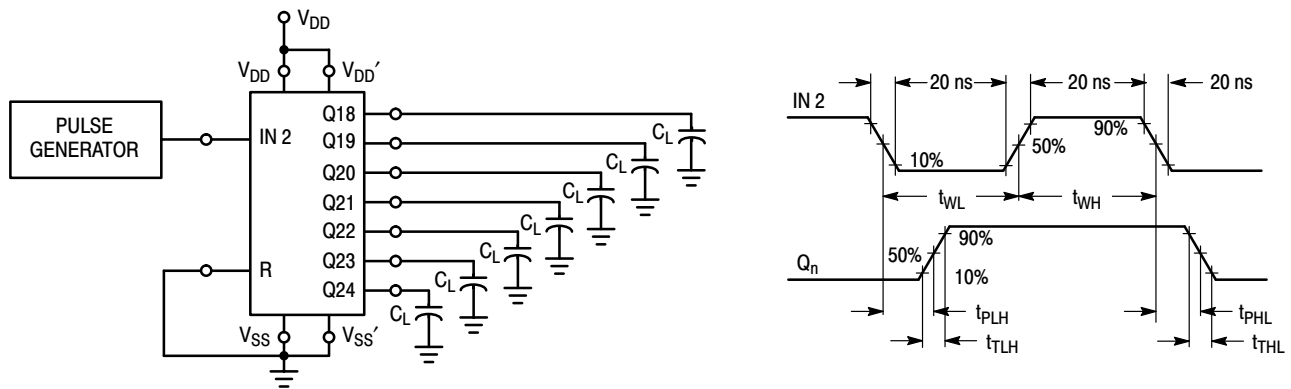
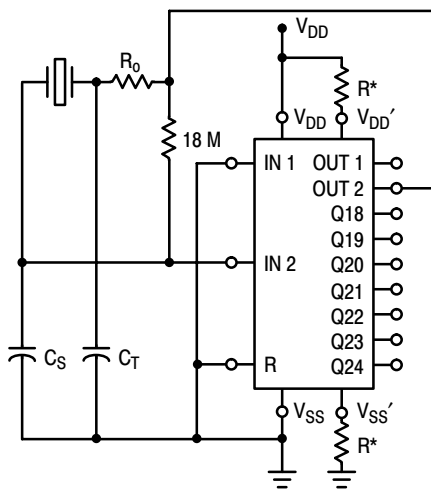

Figure 2. Switching Time Test Circuit and Waveforms



*Optional for low power operation,
 $10 \text{ k}\Omega \leq R \leq 70 \text{ k}\Omega$.

Figure 3. Crystal Oscillator Circuit

Characteristic	500 kHz Circuit	50 kHz Circuit	Unit
Crystal Characteristics			
Resonant Frequency	500	50	kHz
Equivalent Resistance, R_S	1.0	6.2	$\text{k}\Omega$
External Resistor/Capacitor Values			
R_0	47	750	$\text{k}\Omega$
C_T	82	82	pF
C_S	20	20	pF
Frequency Stability			
Frequency Change as a Function of V_{DD} ($T_A = 25^\circ\text{C}$)			
V_{DD} Change from 5.0 V to 10 V	+ 6.0	+ 2.0	ppm
V_{DD} Change from 10 V to 15 V	+ 2.0	+ 2.0	ppm
Frequency Change as a Function of Temperature ($V_{DD} = 10 \text{ V}$)			
T_A Change from -55°C to $+25^\circ\text{C}$	- 4.0	- 2.0	ppm
MC14521 only	+ 100	+ 120	ppm
Complete Oscillator*			
T_A Change from $+25^\circ\text{C}$ to $+125^\circ\text{C}$	- 2.0	- 2.0	ppm
MC14521 only	- 160	- 560	ppm
Complete Oscillator*			

*Complete oscillator includes crystal, capacitors, and resistors.

Figure 4. Typical Data for Crystal Oscillator Circuit

MC14521B

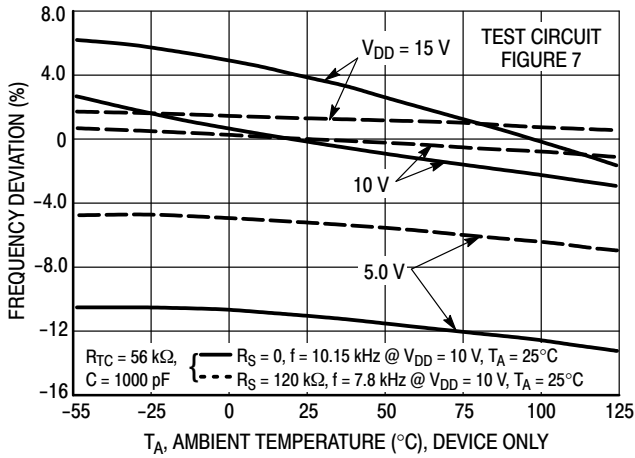

Figure 5. RC Oscillator Stability

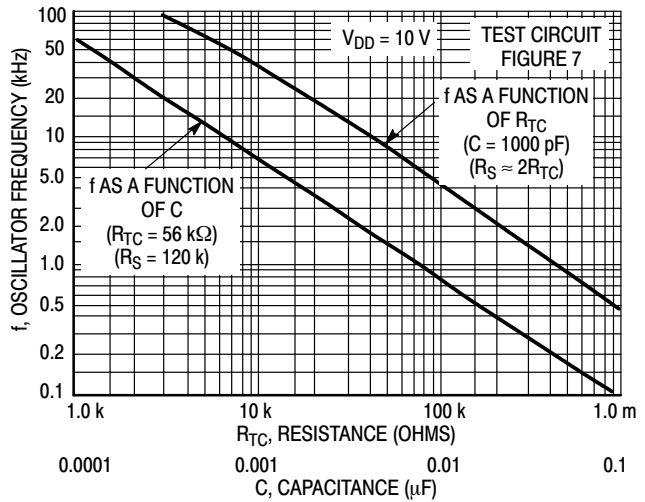

Figure 6. RC Oscillator Frequency as a Function of R_{TC} and C

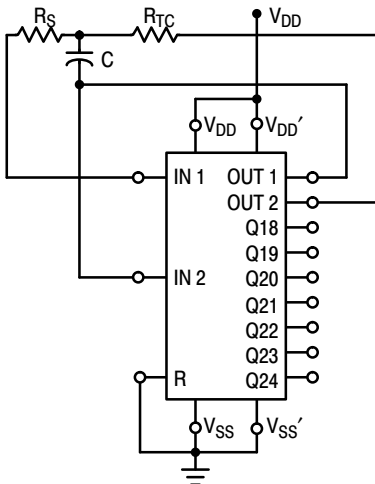

Figure 7. RC Oscillator Circuit

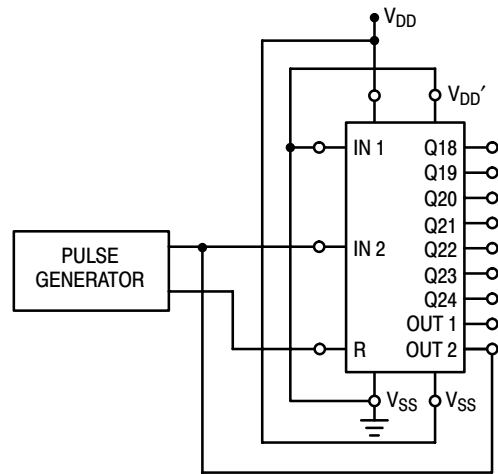

Figure 8. Functional Test Circuit

FUNCTIONAL TEST SEQUENCE

	Inputs		Outputs			Comments	
	Reset	In 2	Out 2	V_{SS}'	V_{DD}'		
<p>A test function (see Figure 8) has been included for the reduction of test time required to exercise all 24 counter stages. This test function divides the counter into three 8-stage sections, and 255 counts are loaded in each of the 8-stage sections in parallel. All flip-flops are now at a logic "1". The counter is now returned to the normal 24-stages in series configuration. One more pulse is entered into Input 2 (In 2) which will cause the counter to ripple from an all "1" state to an all "0" state.</p>	1	0	0	V_{DD}	GND	Counter is in three 8-stage sections in parallel mode. Counter is reset. In 2 and Out 2 are connected together.	
	0	1	1				First "0" to "1" transition on In 2, Out 2 node.
		0	0				255 "0" to "1" transitions are clocked into this In 2, Out 2 node.
		1	1				
		-	-				
		1	1				1
	0	0				1	
	1	0		GND	V_{DD}	1	Counter converted back to 24-stages in series mode.
	1	0				1	Out 2 converts back to an output.
	0	1				0	Counter ripples from an all "1" state to an all "0" stage.

MC14521B

LOGIC DIAGRAM

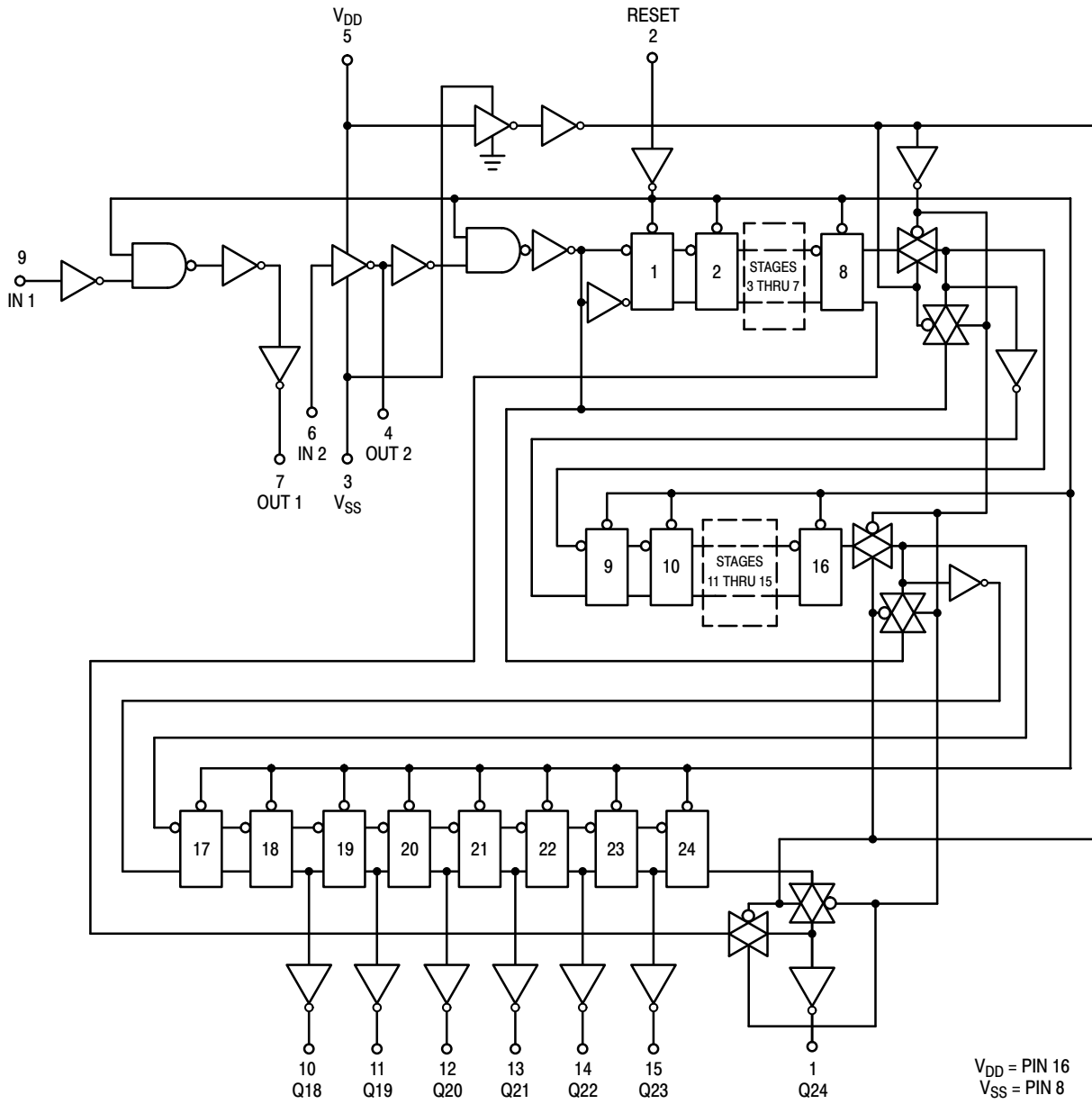

MC14521B

PACKAGE DIMENSIONS

PDIP-16 CASE 648-08 ISSUE T

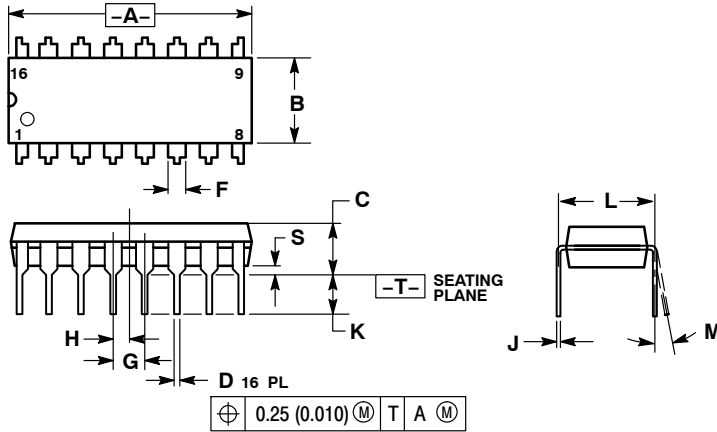

- NOTES:
1. DIMENSIONING AND TOLERANCING PER ANSI Y14.5M, 1982.
 2. CONTROLLING DIMENSION: INCH.
 3. DIMENSION L TO CENTER OF LEADS WHEN FORMED PARALLEL.
 4. DIMENSION B DOES NOT INCLUDE MOLD FLASH.
 5. ROUNDED CORNERS OPTIONAL.

DIM	INCHES		MILLIMETERS	
	MIN	MAX	MIN	MAX
A	0.740	0.770	18.80	19.55
B	0.250	0.270	6.35	6.85
C	0.145	0.175	3.69	4.44
D	0.015	0.021	0.39	0.53
F	0.040	0.70	1.02	1.77
G	0.100 BSC		2.54 BSC	
H	0.050 BSC		1.27 BSC	
J	0.008	0.015	0.21	0.38
K	0.110	0.130	2.80	3.30
L	0.295	0.305	7.50	7.74
M	0°	10°	0°	10°
S	0.020	0.040	0.51	1.01

SOIC-16 CASE 751B-05 ISSUE K

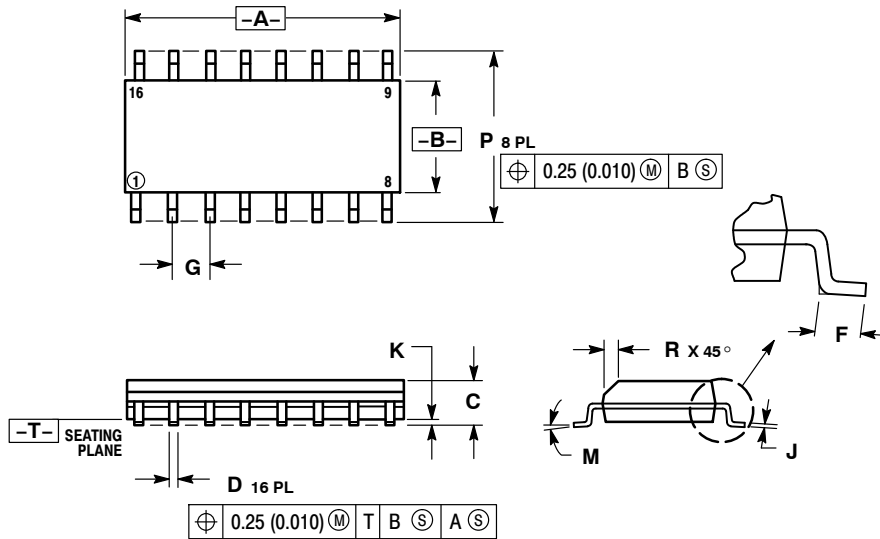

- NOTES:
1. DIMENSIONING AND TOLERANCING PER ANSI Y14.5M, 1982.
 2. CONTROLLING DIMENSION: MILLIMETER.
 3. DIMENSIONS A AND B DO NOT INCLUDE MOLD PROTRUSION.
 4. MAXIMUM MOLD PROTRUSION 0.15 (0.006) PER SIDE.
 5. DIMENSION D DOES NOT INCLUDE DAMBAR PROTRUSION. ALLOWABLE DAMBAR PROTRUSION SHALL BE 0.127 (0.005) TOTAL IN EXCESS OF THE D DIMENSION AT MAXIMUM MATERIAL CONDITION.

DIM	MILLIMETERS		INCHES	
	MIN	MAX	MIN	MAX
A	9.80	10.00	0.386	0.393
B	3.80	4.00	0.150	0.157
C	1.35	1.75	0.054	0.068
D	0.35	0.49	0.014	0.019
F	0.40	1.25	0.016	0.049
G	1.27 BSC		0.050 BSC	
J	0.19	0.25	0.008	0.009
K	0.10	0.25	0.004	0.009
M	0°	7°	0°	7°
P	5.80	6.20	0.229	0.244
R	0.25	0.50	0.010	0.019

SOLDERING FOOTPRINT

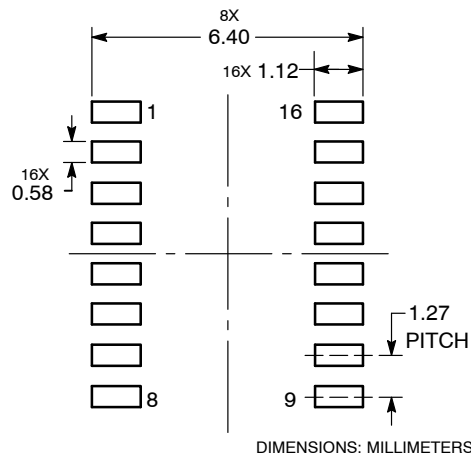

MC14521B

PACKAGE DIMENSIONS

SOEIAJ-16
CASE 966-01
ISSUE A

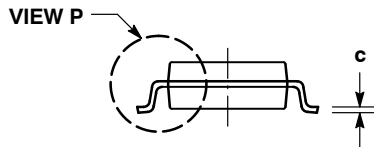
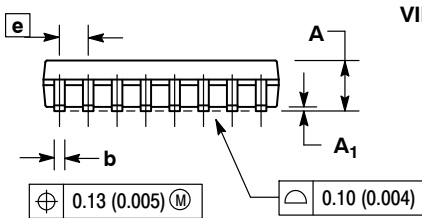
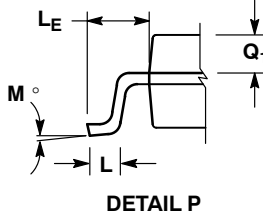
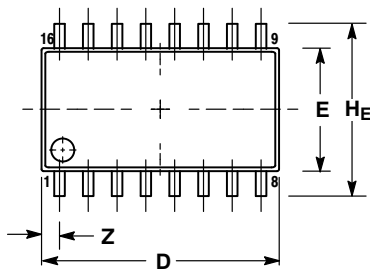

NOTES:

1. DIMENSIONING AND TOLERANCING PER ANSI Y14.5M, 1982.
2. CONTROLLING DIMENSION: MILLIMETER.
3. DIMENSIONS D AND E DO NOT INCLUDE MOLD FLASH OR PROTRUSIONS AND ARE MEASURED AT THE PARTING LINE. MOLD FLASH OR PROTRUSIONS SHALL NOT EXCEED 0.15 (0.006) PER SIDE.
4. TERMINAL NUMBERS ARE SHOWN FOR REFERENCE ONLY.
5. THE LEAD WIDTH DIMENSION (b) DOES NOT INCLUDE DAMBAR PROTRUSION. ALLOWABLE DAMBAR PROTRUSION SHALL BE 0.08 (0.003) TOTAL IN EXCESS OF THE LEAD WIDTH DIMENSION AT MAXIMUM MATERIAL CONDITION. DAMBAR CANNOT BE LOCATED ON THE LOWER RADIUS OR THE FOOT. MINIMUM SPACE BETWEEN PROTRUSIONS AND ADJACENT LEAD TO BE 0.46 (0.018).

DIM	MILLIMETERS		INCHES	
	MIN	MAX	MIN	MAX
A	---	2.05	---	0.081
A ₁	0.05	0.20	0.002	0.008
b	0.35	0.50	0.014	0.020
c	0.10	0.20	0.007	0.011
D	9.90	10.50	0.390	0.413
E	5.10	5.45	0.201	0.215
e	1.27 BSC		0.050 BSC	
HE	7.40	8.20	0.291	0.323
L	0.50	0.85	0.020	0.033
LE	1.10	1.50	0.043	0.059
M	0°	10°	0°	10°
Q ₁	0.70	0.90	0.028	0.035
Z	---	0.78	---	0.031

ON Semiconductor and  are registered trademarks of Semiconductor Components Industries, LLC (SCILLC). SCILLC reserves the right to make changes without further notice to any products herein. SCILLC makes no warranty, representation or guarantee regarding the suitability of its products for any particular purpose, nor does SCILLC assume any liability arising out of the application or use of any product or circuit, and specifically disclaims any and all liability, including without limitation special, consequential or incidental damages. "Typical" parameters which may be provided in SCILLC data sheets and/or specifications can and do vary in different applications and actual performance may vary over time. All operating parameters, including "Typicals" must be validated for each customer application by customer's technical experts. SCILLC does not convey any license under its patent rights nor the rights of others. SCILLC products are not designed, intended, or authorized for use as components in systems intended for surgical implant into the body, or other applications intended to support or sustain life, or for any other application in which the failure of the SCILLC product could create a situation where personal injury or death may occur. Should Buyer purchase or use SCILLC products for any such unintended or unauthorized application, Buyer shall indemnify and hold SCILLC and its officers, employees, subsidiaries, affiliates, and distributors harmless against all claims, costs, damages, and expenses, and reasonable attorney fees arising out of, directly or indirectly, any claim of personal injury or death associated with such unintended or unauthorized use, even if such claim alleges that SCILLC was negligent regarding the design or manufacture of the part. SCILLC is an Equal Opportunity/Affirmative Action Employer. This literature is subject to all applicable copyright laws and is not for resale in any manner.

PUBLICATION ORDERING INFORMATION

LITERATURE FULFILLMENT:

Literature Distribution Center for ON Semiconductor
P.O. Box 5163, Denver, Colorado 80217 USA
Phone: 303-675-2175 or 800-344-3860 Toll Free USA/Canada
Fax: 303-675-2176 or 800-344-3867 Toll Free USA/Canada
Email: orderlit@onsemi.com

N. American Technical Support: 800-282-9855 Toll Free
USA/Canada
Europe, Middle East and Africa Technical Support:
Phone: 421 33 790 2910
Japan Customer Focus Center
Phone: 81-3-5773-3850

ON Semiconductor Website: www.onsemi.com

Order Literature: <http://www.onsemi.com/orderlit>

For additional information, please contact your local Sales Representative

MC14521B/D