

## SYNCHRONOUS PRESETTABLE 4-BIT COUNTER

- HIGH SPEED :  
 $f_{MAX} = 62 \text{ MHz (TYP.) at } V_{CC} = 6V$
- LOW POWER DISSIPATION:  
 $I_{CC} = 4\mu\text{A (MAX.) at } T_A = 25^\circ\text{C}$
- HIGH NOISE IMMUNITY:  
 $V_{NIH} = V_{NIL} = 28\% V_{CC} \text{ (MIN.)}$
- SYMMETRICAL OUTPUT IMPEDANCE:  
 $|I_{OH}| = I_{OL} = 4\text{mA (MIN)}$
- BALANCED PROPAGATION DELAYS:  
 $t_{PLH} \cong t_{PHL}$
- WIDE OPERATING VOLTAGE RANGE:  
 $V_{CC} \text{ (OPR)} = 2V \text{ to } 6V$
- PIN AND FUNCTION COMPATIBLE WITH  
 74 SERIES 161

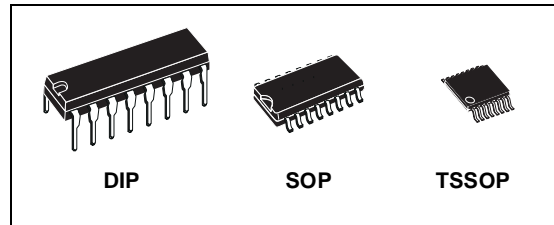

### ORDER CODES

PACKAGE	TUBE	T & R
DIP	M74HC161B1R	
SOP	M74HC161M1R	M74HC161RM13TR
TSSOP		M74HC161TTR

### DESCRIPTION

The M74HC161 is an high speed CMOS SYNCHRONOUS 4-BIT BINARY PRESETTABLE COUNTER fabricated with silicon gate C<sup>2</sup>MOS technology.

The CLOCK input is active on the rising edge. Both LOAD and CLEAR inputs are active LOW. Presetting is synchronous on the rising edge of the clock, the function is cleared asynchronously.

Two enable inputs (TE and PE) and CARRY output are provided to enable easy cascading of counters, which facilitates easy implementation of N-bit counters without using external gates.

All inputs are equipped with protection circuits against static discharge and transient excess voltage.

### PIN CONNECTION AND IEC LOGIC SYMBOLS

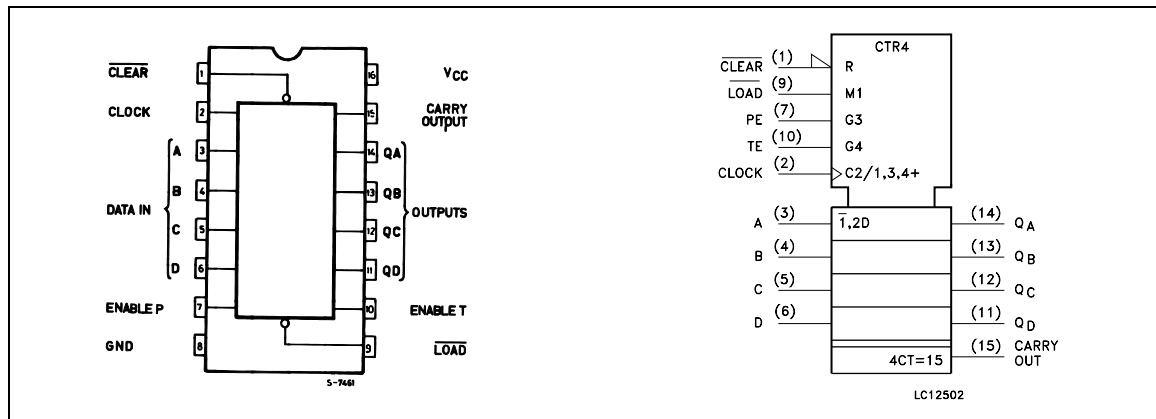

# M74HC161

## INPUT AND OUTPUT EQUIVALENT CIRCUIT

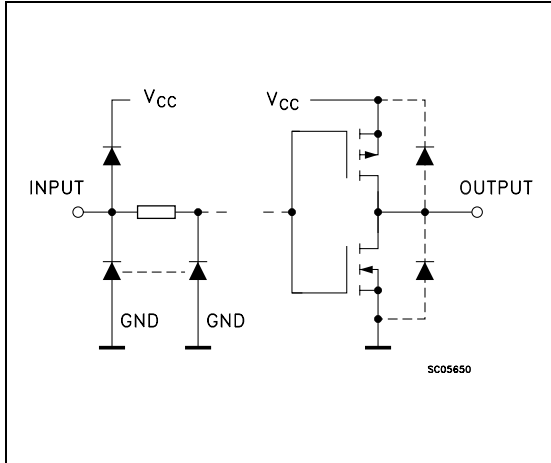

## PIN DESCRIPTION

PIN No	SYMBOL	NAME AND FUNCTION
1	$\overline{\text{CLEAR}}$	Asynchronous Master Reset
2	CLOCK	Clock Input (LOW to HIGH, Edge-triggered)
3, 4, 5, 6	A, B, C, D	Data Inputs
7	PE	Count Enable Input
10	TE	Count Enable Carry Input
9	LOAD	Parallel Enable Input
14, 13, 12, 11	QA to QD	Flip Flop Outputs
15	CARRY	Terminal Count Output
8	GND	Ground (0V)
16	Vcc	Positive Supply Voltage

## TRUTH TABLE

INPUTS					OUTPUTS				FUNCTION
$\overline{\text{CLEAR}}$	$\overline{\text{LOAD}}$	PE	TE	CLOCK	QA	QB	QC	QD	
L	X	X	X	X	L	L	L	L	RESET TO "0"
H	L	X	X		A	B	C	D	PRESET DATA
H	H	X	L		NO CHANGE				NO COUNT
H	H	L	X		NO CHANGE				NO COUNT
H	H	H	H		COUNT UP				COUNT
H	X	X	X		NO CHANGE				NO COUNT

X : Don't Care  
 A, B, C, D : Logic level of data inputs  
 Carry : CARRY = TE·QA·QB·QC·QD

## LOGIC DIAGRAM

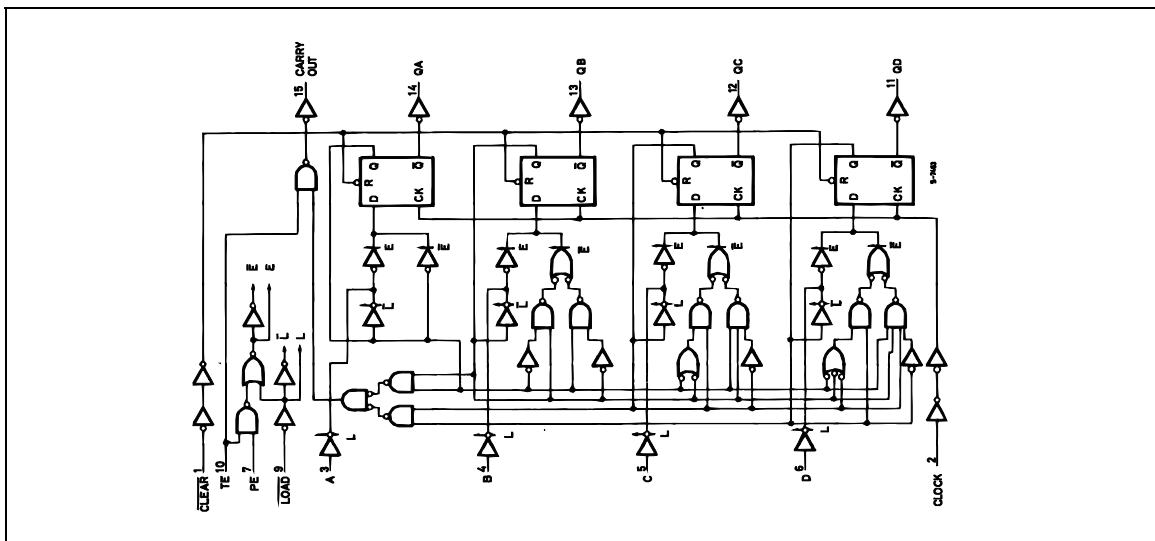

This logic diagram has not be used to estimate propagation delays

## TIMING CHART

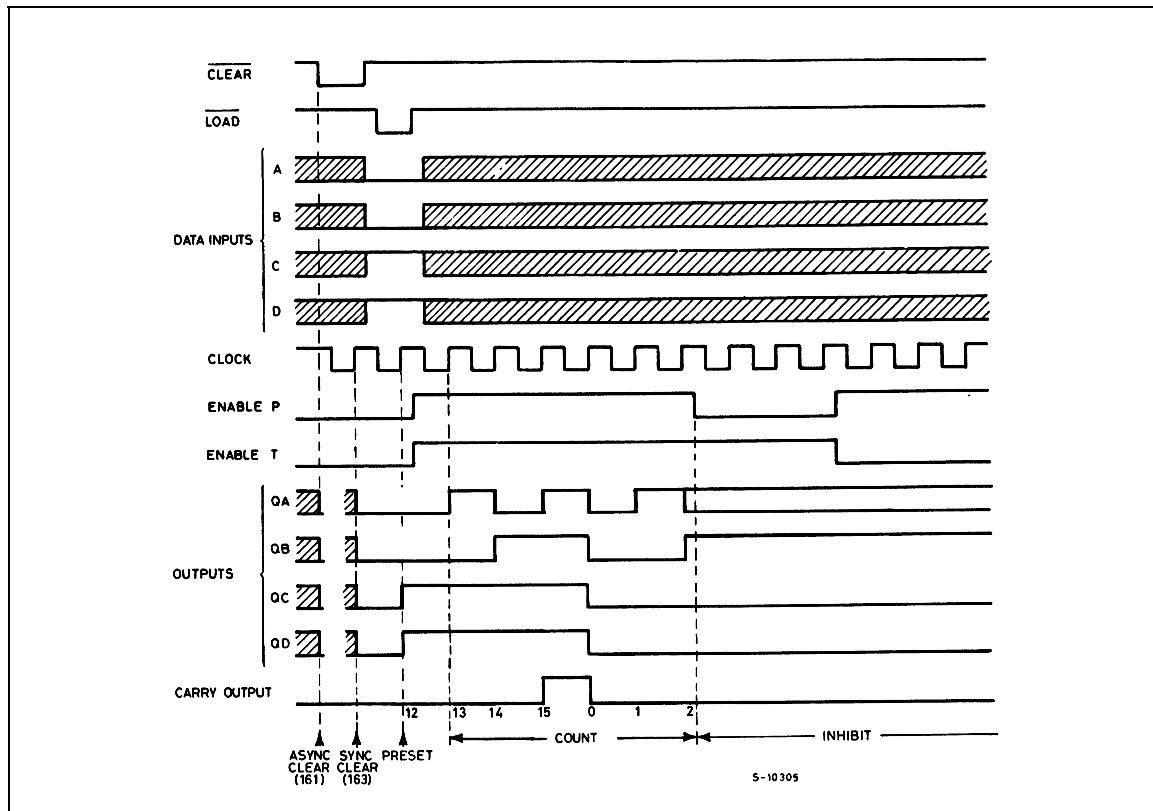

## ABSOLUTE MAXIMUM RATINGS

Symbol	Parameter	Value	Unit
$V_{CC}$	Supply Voltage	-0.5 to +7	V
$V_I$	DC Input Voltage	-0.5 to $V_{CC} + 0.5$	V
$V_O$	DC Output Voltage	-0.5 to $V_{CC} + 0.5$	V
$I_{IK}$	DC Input Diode Current	$\pm 20$	mA
$I_{OK}$	DC Output Diode Current	$\pm 20$	mA
$I_O$	DC Output Current	$\pm 25$	mA
$I_{CC}$ or $I_{GND}$	DC $V_{CC}$ or Ground Current	$\pm 50$	mA
$P_D$	Power Dissipation	500(*)	mW
$T_{stg}$	Storage Temperature	-65 to +150	$^{\circ}\text{C}$
$T_L$	Lead Temperature (10 sec)	300	$^{\circ}\text{C}$

Absolute Maximum Ratings are those values beyond which damage to the device may occur. Functional operation under these conditions is not implied

(\*) 500mW at 65  $^{\circ}\text{C}$ ; derate to 300mW by 10mW/ $^{\circ}\text{C}$  from 65 $^{\circ}\text{C}$  to 85 $^{\circ}\text{C}$

RECOMMENDED OPERATING CONDITIONS

Symbol	Parameter	Value	Unit	
$V_{CC}$	Supply Voltage	2 to 6	V	
$V_I$	Input Voltage	0 to $V_{CC}$	V	
$V_O$	Output Voltage	0 to $V_{CC}$	V	
$T_{op}$	Operating Temperature	-55 to 125	°C	
$t_r, t_f$	Input Rise and Fall Time	$V_{CC} = 2.0V$	0 to 1000	ns
		$V_{CC} = 4.5V$	0 to 500	ns
		$V_{CC} = 6.0V$	0 to 400	ns

DC SPECIFICATIONS

Symbol	Parameter	Test Condition		Value						Unit	
				$T_A = 25^\circ C$			$-40 \text{ to } 85^\circ C$		$-55 \text{ to } 125^\circ C$		
				Min.	Typ.	Max.	Min.	Max.	Min.		Max.
$V_{IH}$	High Level Input Voltage	$V_{CC}$ (V)		1.5			1.5		1.5	V	
				3.15			3.15		3.15		
				4.2			4.2		4.2		
$V_{IL}$	Low Level Input Voltage	$V_{CC}$ (V)				0.5		0.5		0.5	V
						1.35		1.35		1.35	
						1.8		1.8		1.8	
$V_{OH}$	High Level Output Voltage	$V_{CC}$ (V)	$I_O = -20 \mu A$	1.9	2.0		1.9		1.9	V	
				4.4	4.5		4.4		4.4		
				5.9	6.0		5.9		5.9		
				4.18	4.31		4.13		4.10		
				5.68	5.8		5.63		5.60		
$V_{OL}$	Low Level Output Voltage	$V_{CC}$ (V)	$I_O = 20 \mu A$		0.0	0.1		0.1		0.1	V
					0.0	0.1		0.1		0.1	
					0.0	0.1		0.1		0.1	
					0.17	0.26		0.33		0.40	
					0.18	0.26		0.33		0.40	
$I_I$	Input Leakage Current	6.0	$V_I = V_{CC}$ or GND			$\pm 0.1$		$\pm 1$		$\pm 1$	$\mu A$
$I_{CC}$	Quiescent Supply Current	6.0	$V_I = V_{CC}$ or GND			4		40		80	$\mu A$

AC ELECTRICAL CHARACTERISTICS ( $C_L = 50 \text{ pF}$ , Input  $t_r = t_f = 6 \text{ ns}$ )

Symbol	Parameter	Test Condition		Value						Unit		
		$V_{CC}$ (V)		$T_A = 25^\circ\text{C}$			$-40 \text{ to } 85^\circ\text{C}$		$-55 \text{ to } 125^\circ\text{C}$			
				Min.	Typ.	Max.	Min.	Max.	Min.		Max.	
$t_{TLH}$ $t_{THL}$	Output Transition Time	2.0			25	75			95		110	ns
		4.5			7	15			19		22	
		6.0			6	13			16		19	
$t_{PLH}$ $t_{PHL}$	Propagation Delay Time (CLOCK - Q)	2.0			48	125			155		190	ns
		4.5			16	25			31		38	
		6.0			14	21			26		32	
$t_{PLH}$ $t_{PHL}$	Propagation Delay Time (CLOCK - CARRY)	2.0			57	150			190		225	ns
		4.5			19	30			38		45	
		6.0			16	26			32		38	
$t_{PLH}$ $t_{PHL}$	Propagation Delay Time (TE - CARRY)	2.0			39	100			125		150	ns
		4.5			13	20			25		30	
		6.0			11	17			21		26	
$t_{PLH}$	Propagation Delay Time ( $\overline{\text{CLEAR}}$ - Q)	2.0			60	150			190		225	ns
		4.5			20	30			38		45	
		6.0			17	26			32		38	
$t_{PHL}$	Propagation Delay Time ( $\overline{\text{CLEAR}}$ - CARRY)	2.0			72	200			250		300	ns
		4.5			24	40			50		60	
		6.0			20	34			43		51	
$f_{MAX}$	Maximum Clock Frequency	2.0			6.2	18			5		4.2	MHz
		4.5			31	53			25		21	
		6.0			37	62			30		25	
$t_{W(H)}$ $t_{W(L)}$	Minimum Pulse Width (CLOCK)	2.0			18	75			95		110	ns
		4.5			6	15			19		22	
		6.0			6	13			16		19	
$t_{W(L)}$	Minimum Pulse Width (CLEAR)	2.0			24	75			95		110	ns
		4.5			7	15			19		22	
		6.0			6	13			16		19	
$t_s$	Minimum Set-up Time (LOAD, PE, TE)	2.0			40	100			125		150	ns
		4.5			10	20			25		30	
		6.0			8	17			21		26	
$t_s$	Minimum Set-up Time (A, B, C, D)	2.0			20	75			95		110	ns
		4.5			5	15			19		22	
		6.0			3	13			16		19	
$t_h$	Minimum Hold Time (A, B - CLOCK)	2.0				0			0		0	ns
		4.5				0			0		0	
		6.0				0			0		0	
$t_{REM}$	Minimum Removal Time	2.0			18	50			65		75	ns
		4.5			4	10			13		15	
		6.0			3	9			11		13	

**CAPACITIVE CHARACTERISTICS**

Symbol	Parameter	Test Condition $V_{CC}$ (V)	Value						Unit	
			$T_A = 25^\circ\text{C}$			-40 to 85°C		-55 to 125°C		
			Min.	Typ.	Max.	Min.	Max.	Min.		Max.
$C_{IN}$	Input Capacitance	5.0		5	10		10		10	pF
$C_{PD}$	Power Dissipation Capacitance (note 1)	5.0		50						pF

1)  $C_{PD}$  is defined as the value of the IC's internal equivalent capacitance which is calculated from the operating current consumption without load. (Refer to Test Circuit). Average operating current can be obtained by the following equation.  $I_{CC(oper)} = C_{PD} \times V_{CC} \times f_{IN} + I_{CC}$

**TEST CIRCUIT**

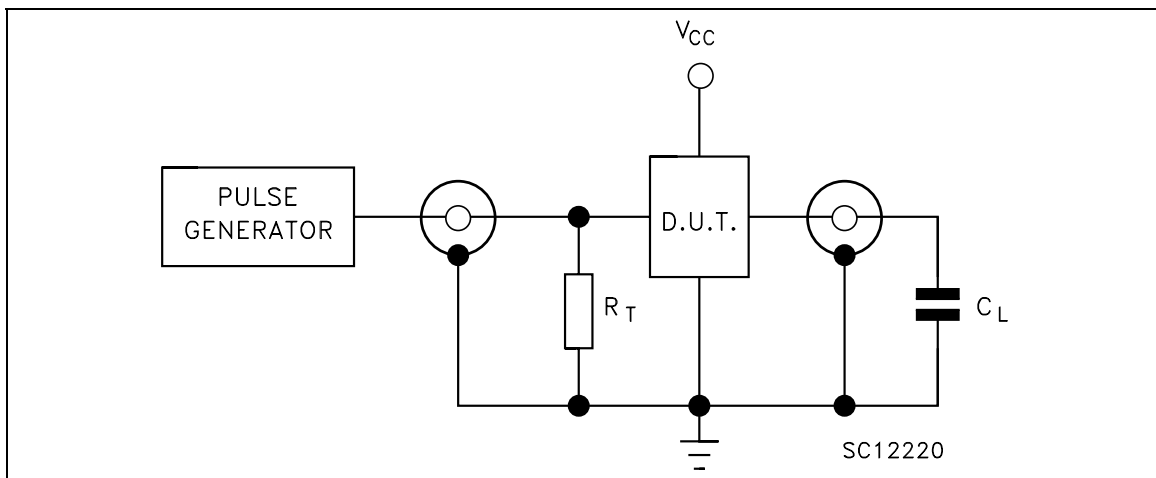

$C_L = 50\text{pF}$  or equivalent (includes jig and probe capacitance)  
 $R_T = Z_{OUT}$  of pulse generator (typically  $50\Omega$ )

**WAVEFORM 1: PROPAGATION DELAY TIMES, CLOCK MINIMUM PULSE WIDTH**

( $f=1\text{MHz}$ ; 50% duty cycle)

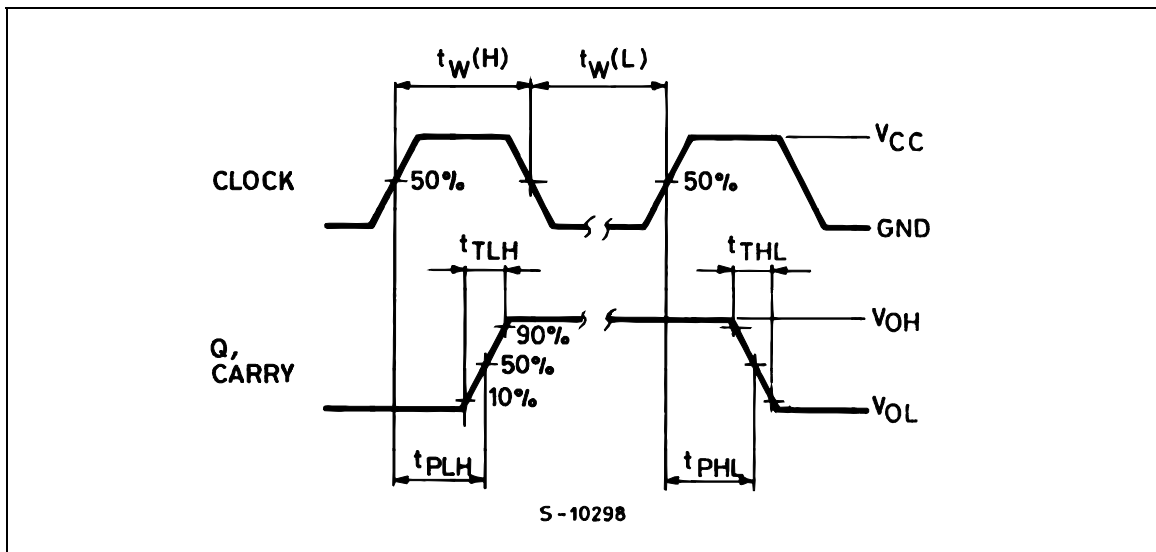

**WAVEFORM 2 : PROPAGATION DELAY TIMES, CLEAR MINIMUM PULSE WIDTH (CLEAR MODE)**  
 (f=1MHz; 50% duty cycle)

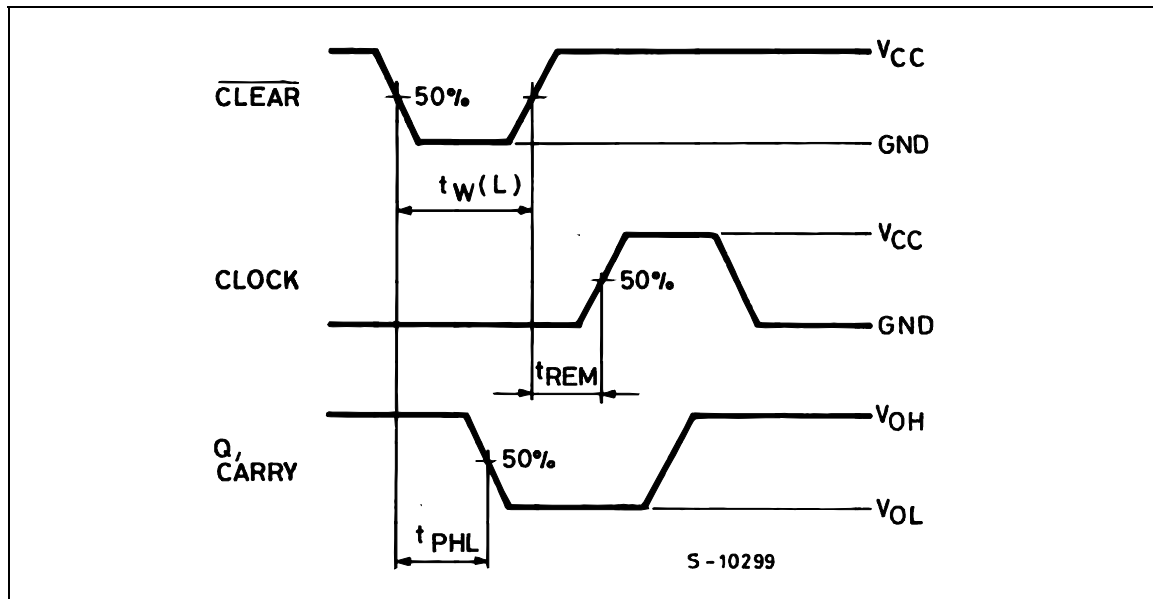

**WAVEFORM 3 : SETUP AND HOLD TIMES (PRESET MODE)** (f=1MHz; 50% duty cycle)

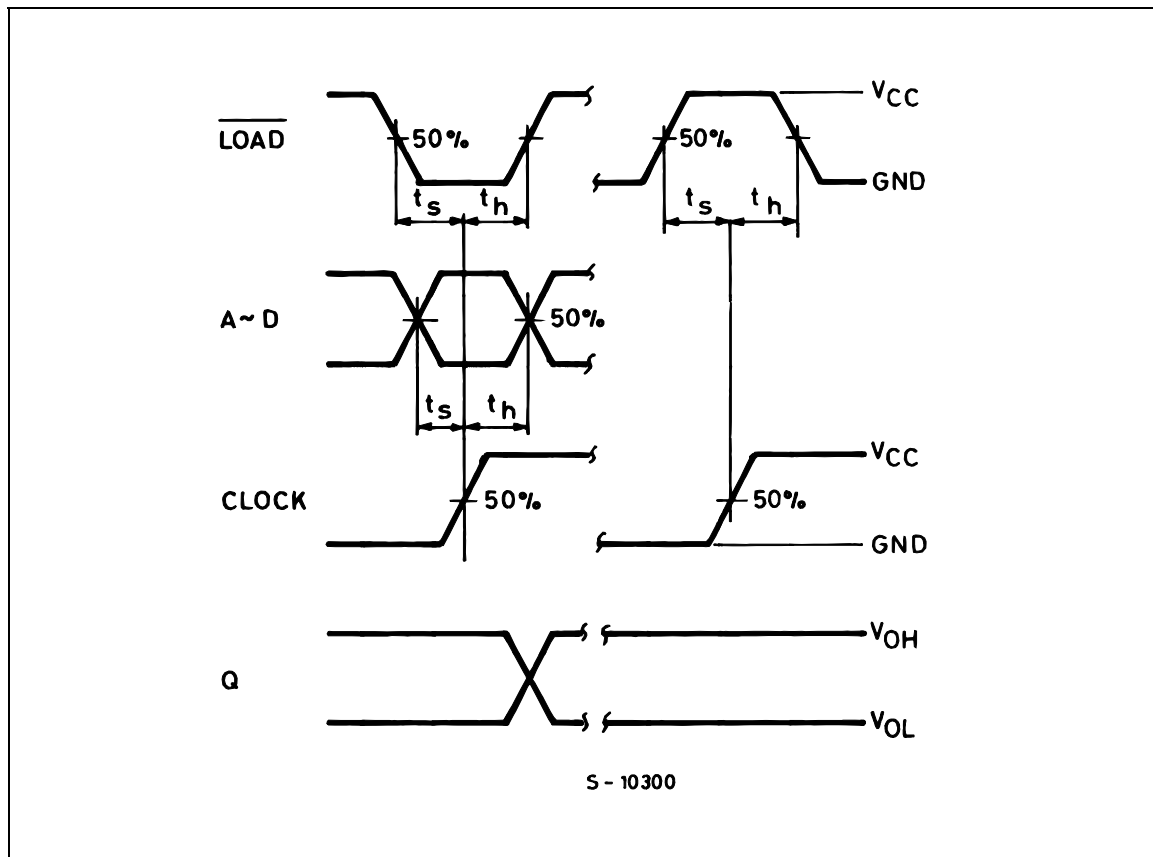

WAVEFORM 4 : SETUP AND HOLD TIMES (COUNTENABLE MODE) (f=1MHz; 50% duty cycle)

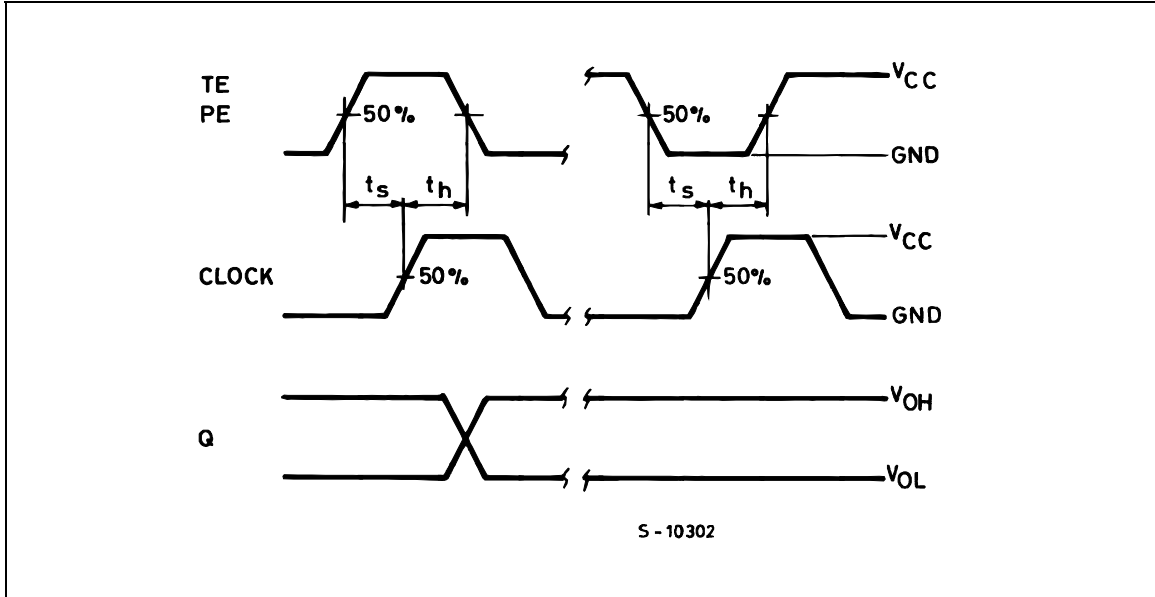

WAVEFORM 5 : PROPAGATION DELAY TIMES (CASCADE MODE) (f=1MHz; 50% duty cycle)

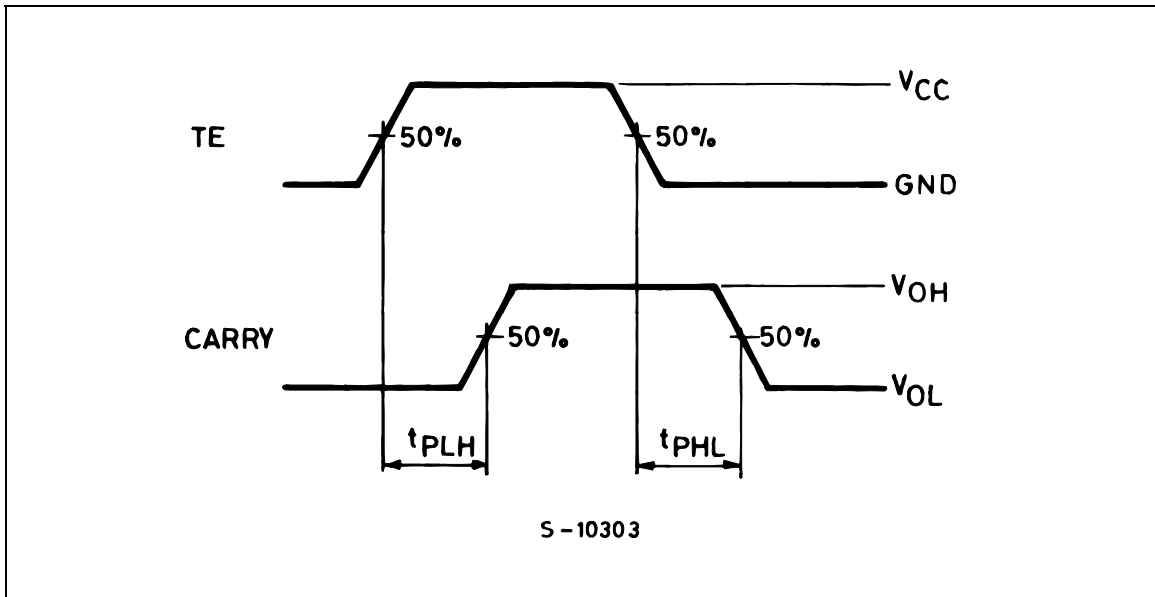



**Plastic DIP-16 (0.25) MECHANICAL DATA**

DIM.	mm.			inch		
	MIN.	TYP	MAX.	MIN.	TYP.	MAX.
a1	0.51			0.020		
B	0.77		1.65	0.030		0.065
b		0.5			0.020	
b1		0.25			0.010	
D			20			0.787
E		8.5			0.335	
e		2.54			0.100	
e3		17.78			0.700	
F			7.1			0.280
I			5.1			0.201
L		3.3			0.130	
Z			1.27			0.050

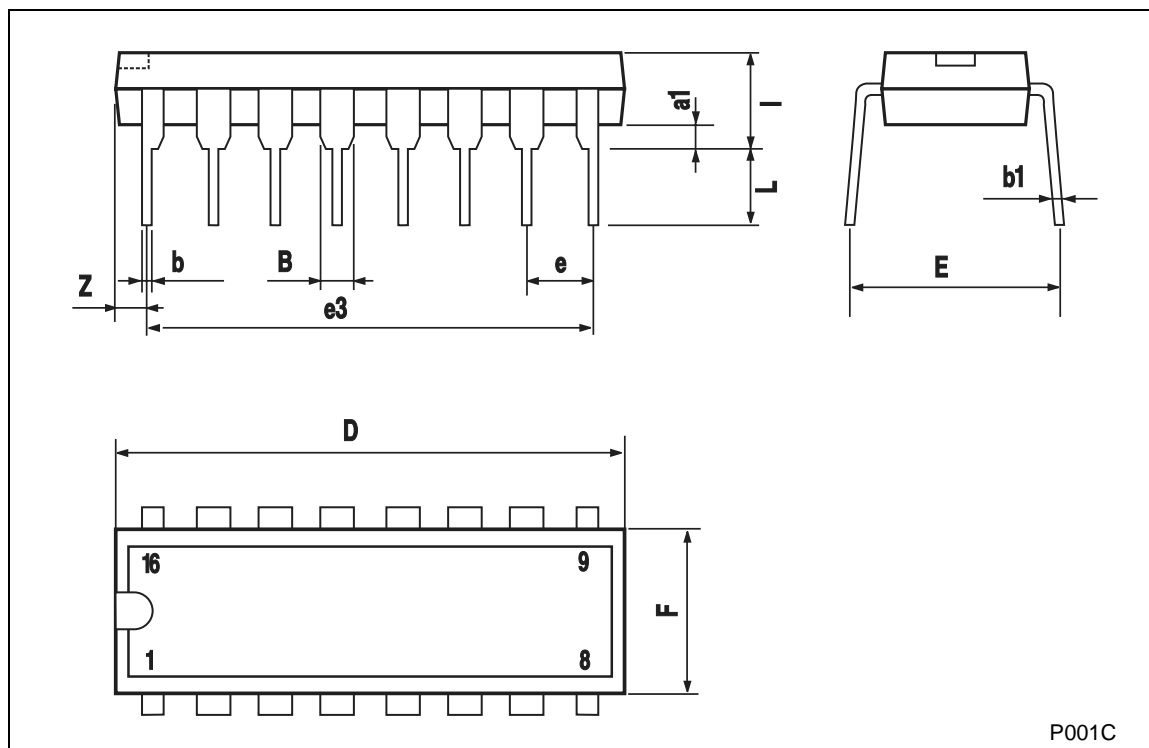

## SO-16 MECHANICAL DATA

DIM.	mm.			inch		
	MIN.	TYP	MAX.	MIN.	TYP.	MAX.
A			1.75			0.068
a1	0.1		0.2	0.003		0.007
a2			1.65			0.064
b	0.35		0.46	0.013		0.018
b1	0.19		0.25	0.007		0.010
C		0.5			0.019	
c1	45° (typ.)					
D	9.8		10	0.385		0.393
E	5.8		6.2	0.228		0.244
e		1.27			0.050	
e3		8.89			0.350	
F	3.8		4.0	0.149		0.157
G	4.6		5.3	0.181		0.208
L	0.5		1.27	0.019		0.050
M			0.62			0.024
S	8° (max.)					

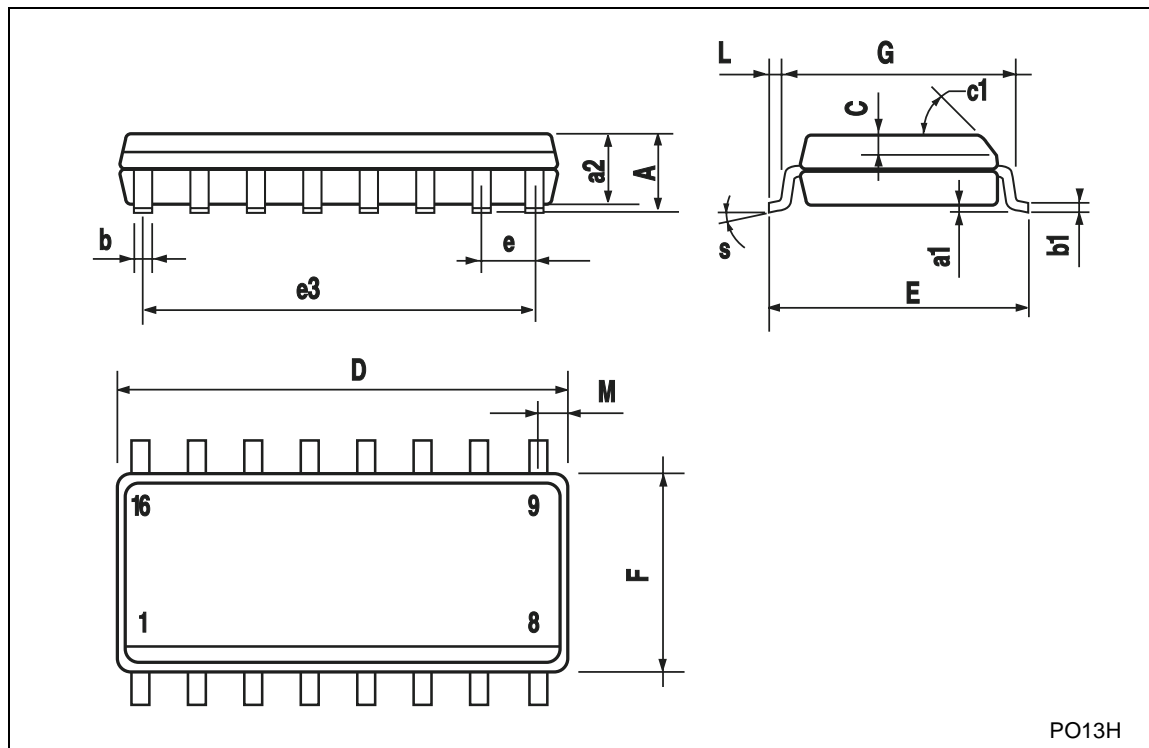

## TSSOP16 MECHANICAL DATA

DIM.	mm.			inch		
	MIN.	TYP	MAX.	MIN.	TYP.	MAX.
A			1.2			0.047
A1	0.05		0.15	0.002	0.004	0.006
A2	0.8	1	1.05	0.031	0.039	0.041
b	0.19		0.30	0.007		0.012
c	0.09		0.20	0.004		0.0089
D	4.9	5	5.1	0.193	0.197	0.201
E	6.2	6.4	6.6	0.244	0.252	0.260
E1	4.3	4.4	4.48	0.169	0.173	0.176
e		0.65 BSC			0.0256 BSC	
K	0°		8°	0°		8°
L	0.45	0.60	0.75	0.018	0.024	0.030

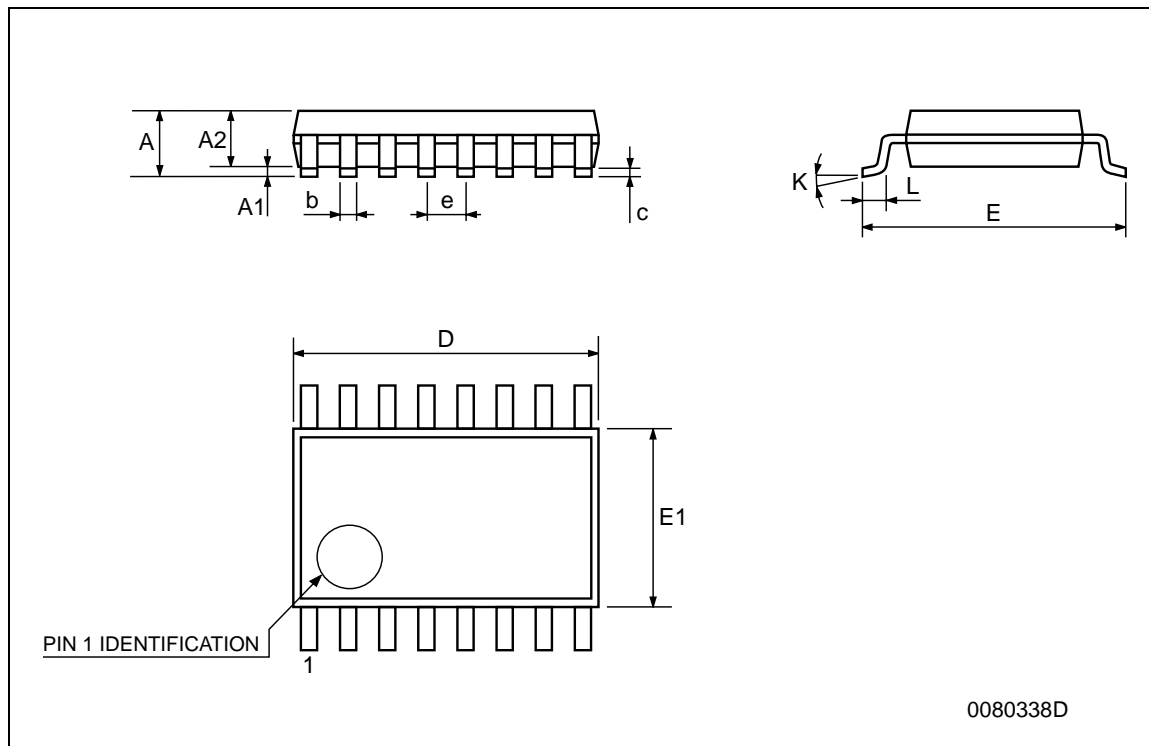

Information furnished is believed to be accurate and reliable. However, STMicroelectronics assumes no responsibility for the consequences of use of such information nor for any infringement of patents or other rights of third parties which may result from its use. No license is granted by implication or otherwise under any patent or patent rights of STMicroelectronics. Specifications mentioned in this publication are subject to change without notice. This publication supersedes and replaces all information previously supplied. STMicroelectronics products are not authorized for use as critical components in life support devices or systems without express written approval of STMicroelectronics.

© The ST logo is a registered trademark of STMicroelectronics

© 2001 STMicroelectronics - Printed in Italy - All Rights Reserved  
STMicroelectronics GROUP OF COMPANIES

Australia - Brazil - China - Finland - France - Germany - Hong Kong - India - Italy - Japan - Malaysia - Malta - Morocco  
Singapore - Spain - Sweden - Switzerland - United Kingdom

© <http://www.st.com>

