



# 74VHCT16244A

## 16-BIT BUS BUFFER WITH 3-STATE OUTPUTS (NON INVERTED)

- HIGH SPEED:  
 $t_{PD} = 5.4 \text{ ns}$  (TYP.) at  $V_{CC} = 5V$
- LOW POWER DISSIPATION:  
 $I_{CC} = 4 \mu\text{A}$  (MAX.) at  $T_A = 25^\circ\text{C}$
- COMPATIBLE WITH TTL OUTPUTS:  
 $V_{IH} = 2V$  (MIN.)  $V_{IL} = 0.8$  (MAX.)
- POWER DOWN PROTECTION ON INPUTS
- SYMMETRICAL OUTPUT IMPEDANCE:  
 $|I_{OH}| = I_{OL} = 8 \text{ mA}$  (MIN)
- BALANCED PROPAGATION DELAYS:  
 $t_{PLH} \approx t_{PHL}$
- OPERATING VOLTAGE RANGE:  
 $V_{CC}(\text{OPR}) = 4.5V$  to  $5.5V$
- PIN AND FUNCTION COMPATIBLE WITH  
74 SERIES 16244
- IMPROVED LATCH-UP IMMUNITY
- LOW NOISE:  $V_{OLP} = 0.9V$  (MAX.)

### DESCRIPTION

The 74VHCT16244A is an advanced high-speed CMOS 16-BIT BUS BUFFER (3-STATE) fabricated with sub-micron silicon gate and double-layer metal wiring C<sup>2</sup>MOS technology.

Any  $\overline{nG}$  output control governs four BUS BUFFERS. Output Enable inputs ( $\overline{nG}$ ) tied together give full 16 bit operation.

When  $\overline{nG}$  is LOW, the outputs are enabled. When  $\overline{nG}$  is HIGH, the output are in high impedance state.

The device is designed to be used with 3-state memory address drivers, etc.

Power down protection is provided on all inputs and 0 to 7V can be accepted on inputs with no regard to the supply voltage. This device can be used to interface 5V to 3V.

All inputs and outputs are equipped with protection circuits against static discharge, giving them 2KV ESD immunity and transient excess voltage.



### ORDER CODES

PACKAGE	TUBE	T & R
TSSOP		74VHCT16244ATTR

### PIN CONNECTION

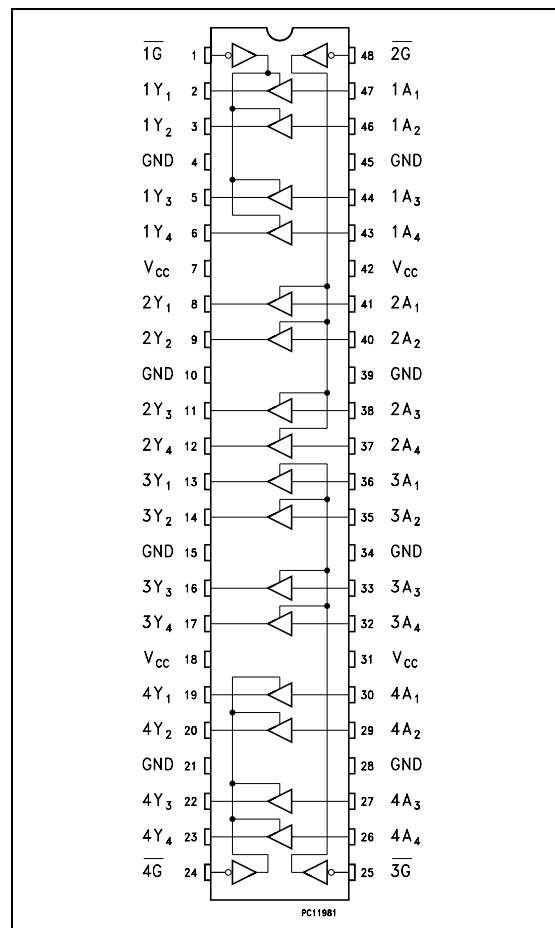

INPUT EQUIVALENT CIRCUIT

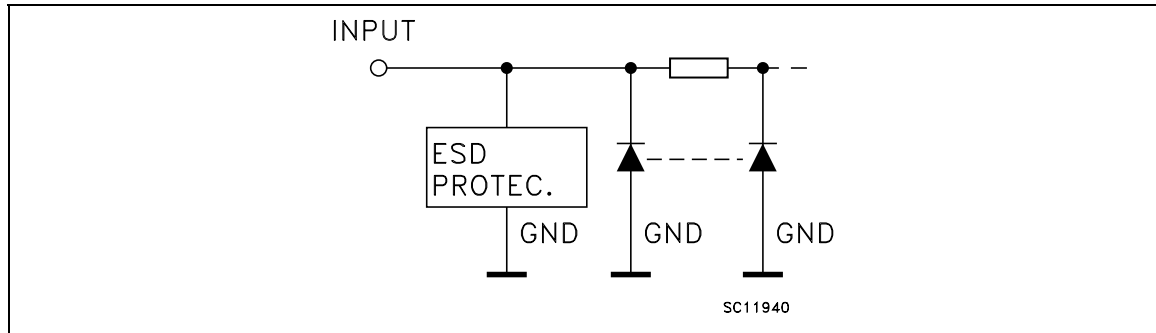

PIN DESCRIPTION

PIN No	SYMBOL	NAME AND FUNCTION
1	1G	Output Enable Input
2, 3, 5, 6	1Y1 to 1Y4	Data Outputs
8, 9, 11, 12	2Y1 to 2Y4	Data Outputs
13, 14, 16, 17	3Y1 to 3Y4	Data Outputs
19, 20, 22, 23	4Y1 to 4Y4	Data Outputs
24	4G	Output Enable Input
25	3G	Output Enable Input
30, 29, 27, 26	4A1 to 4A4	Data Outputs
36, 35, 33, 32	3A1 to 3A4	Data Outputs
41, 40, 38, 37	2A1 to 2A4	Data Outputs
47, 46, 44, 43	1A1 to 1A4	Data Outputs
48	2G	Output Enable Input
4, 10, 15, 21, 28, 34, 39, 45	GND	Ground (0V)
7, 18, 31, 42	V <sub>CC</sub>	Positive Supply Voltage

IEC LOGIC SYMBOLS

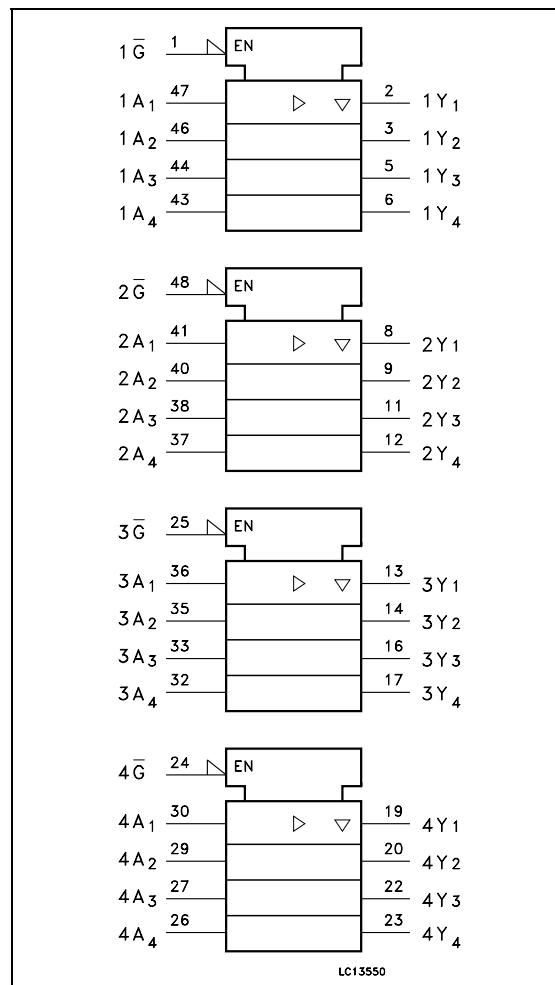

TRUTH TABLE

INPUTS		OUTPUT
$\bar{G}$	A <sub>n</sub>	Y <sub>n</sub>
L	L	L
L	H	H
H	X	Z

X : Don't Care  
Z : High Impedance

**ABSOLUTE MAXIMUM RATINGS**

Symbol	Parameter	Value	Unit
$V_{CC}$	Supply Voltage	-0.5 to +7.0	V
$V_I$	DC Input Voltage	-0.5 to +7.0	V
$V_O$	DC Output Voltage	-0.5 to $V_{CC} + 0.5$	V
$I_{IK}$	DC Input Diode Current	- 20	mA
$I_{OK}$	DC Output Diode Current	$\pm 20$	mA
$I_O$	DC Output Current	$\pm 25$	mA
$I_{CC}$ or $I_{GND}$	DC $V_{CC}$ or Ground Current	$\pm 75$	mA
$T_{stg}$	Storage Temperature	-65 to +150	°C
$T_L$	Lead Temperature (10 sec)	300	°C

Absolute Maximum Ratings are those values beyond which damage to the device may occur. Functional operation under these conditions is not implied

**RECOMMENDED OPERATING CONDITIONS**

Symbol	Parameter	Value	Unit
$V_{CC}$	Supply Voltage	4.5 to 5.5	V
$V_I$	Input Voltage	0 to 5.5	V
$V_O$	Output Voltage	0 to $V_{CC}$	V
$T_{op}$	Operating Temperature	-55 to 125	°C
dt/dv	Input Rise and Fall Time (note 1) ( $V_{CC} = 5.0 \pm 0.5V$ )	0 to 20	ns/V

1)  $V_{IN}$  from 0.8V to 2.0V

## DC SPECIFICATIONS

Symbol	Parameter	Test Condition		Value						Unit	
		V <sub>CC</sub> (V)		T <sub>A</sub> = 25°C			-40 to 85°C		-55 to 125°C		
				Min.	Typ.	Max.	Min.	Max.	Min.		Max.
V <sub>IH</sub>	High Level Input Voltage	4.5 to 5.5		2			2		2		V
V <sub>IL</sub>	Low Level Input Voltage	4.5 to 5.5				0.8		0.8		0.8	V
V <sub>OH</sub>	High Level Output Voltage	4.5	I <sub>O</sub> =-50 μA	4.4	4.5		4.4		4.4		V
		4.5	I <sub>O</sub> =-8 mA	3.94			3.8		3.7		
V <sub>OL</sub>	Low Level Output Voltage	4.5	I <sub>O</sub> =50 μA		0.0	0.1		0.1		0.1	V
		4.5	I <sub>O</sub> =8 mA			0.36		0.44		0.55	
I <sub>OZ</sub>	High Impedance Output Leakage Current	5.5	V <sub>I</sub> = V <sub>IH</sub> or V <sub>IL</sub> V <sub>O</sub> = V <sub>CC</sub> or GND			±0.25		± 2.5		± 2.5	μA
I <sub>I</sub>	Input Leakage Current	0 to 5.5	V <sub>I</sub> = 5.5V or GND			± 0.1		± 1		± 1	μA
I <sub>CC</sub>	Quiescent Supply Current	5.5	V <sub>I</sub> = V <sub>CC</sub> or GND			4		40		40	μA

AC ELECTRICAL CHARACTERISTICS (Input t<sub>r</sub> = t<sub>f</sub> = 3ns)

Symbol	Parameter	Test Condition		Value						Unit	
		V <sub>CC</sub> (*) (V)	C <sub>L</sub> (pF)	T <sub>A</sub> = 25°C			-40 to 85°C		-55 to 125°C		
				Min.	Typ.	Max.	Min.	Max.	Min.		Max.
t <sub>PLH</sub> t <sub>PHL</sub>	Propagation Delay Time	5.0	15		5.4	8.5	1.0	9.5	1.0	10.0	ns
		5.0	50		7	9.5	1.0	10.5	1.0	11.0	
t <sub>PLZ</sub> t <sub>PHZ</sub>	Output Disable Time	5.0	15	RL = 1KΩ	7.7	10.4	1.0	12.0	1.0	12.0	ns
		5.0	50		8.2	11.4	1.0	13.0	1.0	13.0	
t <sub>PZL</sub> t <sub>PZH</sub>	Output Enable Time	5.0	50	RL = 1KΩ	8.8	11.4	1.0	13.0	1.0	13.0	ns

(\*) Voltage range is 5.0V ± 0.5V

## CAPACITIVE CHARACTERISTICS

Symbol	Parameter	Test Condition		Value						Unit	
		V <sub>CC</sub> (V)		T <sub>A</sub> = 25°C			-40 to 85°C		-55 to 125°C		
				Min.	Typ.	Max.	Min.	Max.	Min.		Max.
C <sub>IN</sub>	Input Capacitance				4	10		10		10	pF
C <sub>OUT</sub>	Output Capacitance				6						pF
C <sub>PD</sub>	Power Dissipation Capacitance (note 1)	5.0	f <sub>IN</sub> = 10MHz		21						pF

1) C<sub>PD</sub> is defined as the value of the IC's internal equivalent capacitance which is calculated from the operating current consumption without load. (Refer to Test Circuit). Average operating current can be obtained by the following equation. I<sub>CC(opr)</sub> = C<sub>PD</sub> × V<sub>CC</sub> × f<sub>IN</sub> + I<sub>CC/16</sub> (per Latch)

## DYNAMIC SWITCHING CHARACTERISTICS

Symbol	Parameter	Test Condition		Value				Unit			
		$V_{CC}$ (V)	$C_L = 50 \text{ pF}$	$T_A = 25^\circ\text{C}$			$-40 \text{ to } 85^\circ\text{C}$		$-55 \text{ to } 125^\circ\text{C}$		
				Min.	Typ.	Max.	Min.		Max.	Min.	Max.
$V_{OLP}$	Dynamic Low Voltage Quiet Output (note 1, 2)	5.0	$C_L = 50 \text{ pF}$		0.6	0.9					V
$V_{OLV}$				-0.9	-0.6						
$V_{IHD}$	Dynamic High Voltage Input (note 1, 3)	5.0		3.5						V	
$V_{ILD}$	Dynamic Low Voltage Input (note 1, 3)	5.0				1.5				V	

1) Worst case package.

2) Max number of outputs defined as (n). Data inputs are driven 0V to 5.0V, (n-1) outputs switching and one output at GND.

3) Max number of data inputs (n) switching. (n-1) switching 0V to 5.0V. Inputs under test switching: 5.0V to threshold ( $V_{ILD}$ ), 0V to threshold ( $V_{IHD}$ ),  $f=1\text{MHz}$ .

## TEST CIRCUIT

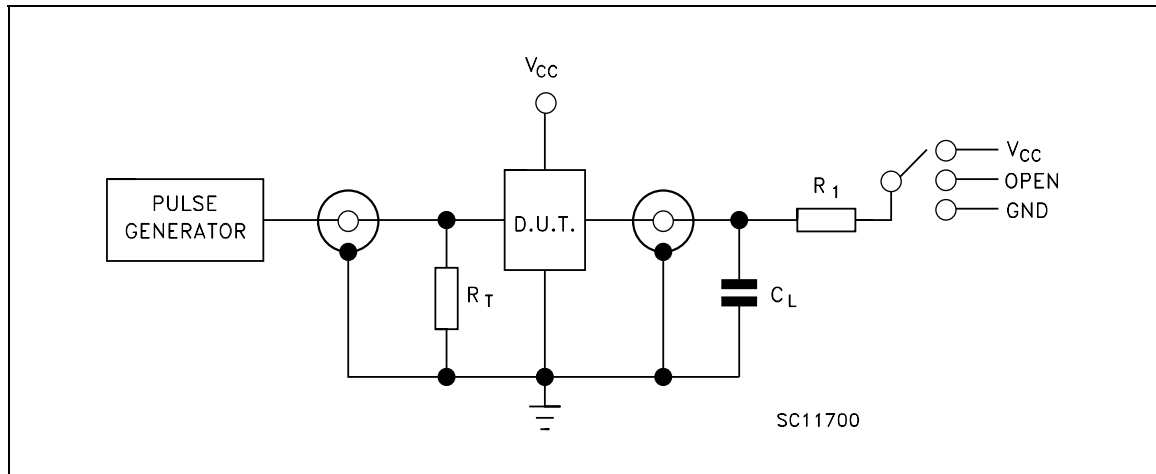

TEST	SWITCH
$t_{PLH}$ , $t_{PHL}$	Open
$t_{PZL}$ , $t_{PLZ}$	$V_{CC}$
$t_{PZH}$ , $t_{PHZ}$	GND

$C_L = 15/50 \text{ pF}$  or equivalent (includes jig and probe capacitance)

$R_L = R_1 = 1\text{K}\Omega$  or equivalent

$R_T = Z_{OUT}$  of pulse generator (typically  $50\Omega$ )

WAVEFORM 1: PROPAGATION DELAYS (f=1MHz; 50% duty cycle)

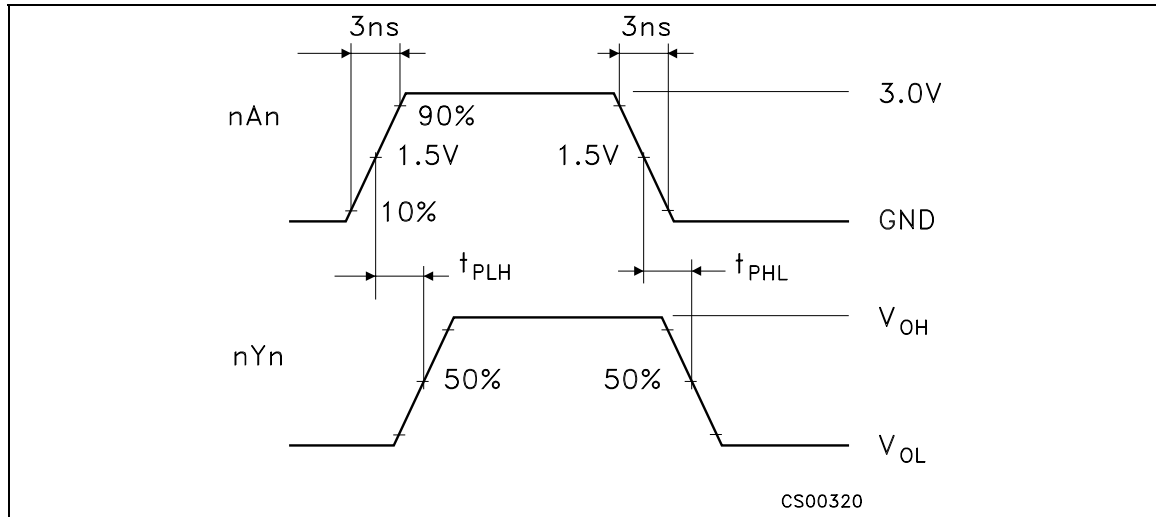

WAVEFORM 2: OUTPUT ENABLE AND DISABLE TIME (f=1MHz; 50% duty cycle)

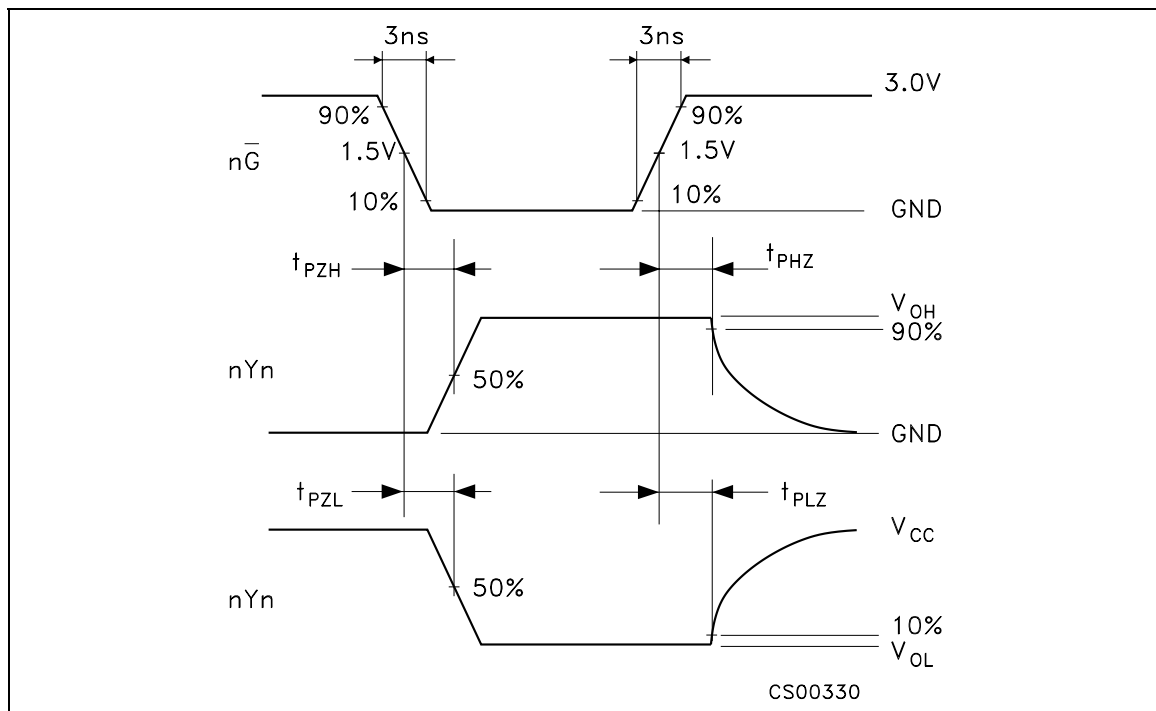

## TSSOP48 MECHANICAL DATA

DIM.	mm.			inch		
	MIN.	TYP	MAX.	MIN.	TYP.	MAX.
A			1.2			0.047
A1	0.05		0.15	0.002		0.006
A2		0.9			0.035	
b	0.17		0.27	0.0067		0.011
c	0.09		0.20	0.0035		0.0079
D	12.4		12.6	0.488		0.496
E		8.1 BSC			0.318 BSC	
E1	6.0		6.2	0.236		0.244
e		0.5 BSC			0.0197 BSC	
K	0°		8°	0°		8°
L	0.50		0.75	0.020		0.030

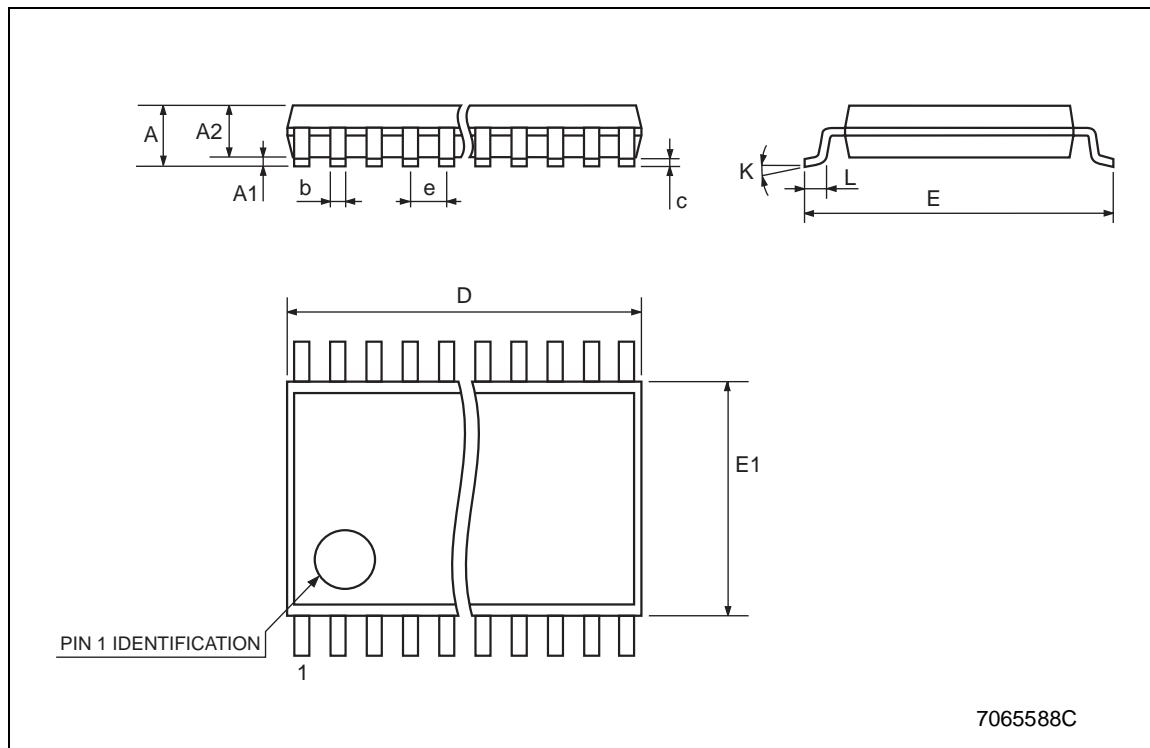

## Tape &amp; Reel TSSOP48 MECHANICAL DATA

DIM.	mm.			inch		
	MIN.	TYP.	MAX.	MIN.	TYP.	MAX.
A			330			12.992
C	12.8		13.2	0.504		0.519
D	20.2			0.795		
N	60			2.362		
T			30.4			1.197
Ao	8.7		8.9	0.343		0.350
Bo	13.1		13.3	0.516		0.524
Ko	1.5		1.7	0.059		0.067
Po	3.9		4.1	0.153		0.161
P	11.9		12.1	0.468		0.476

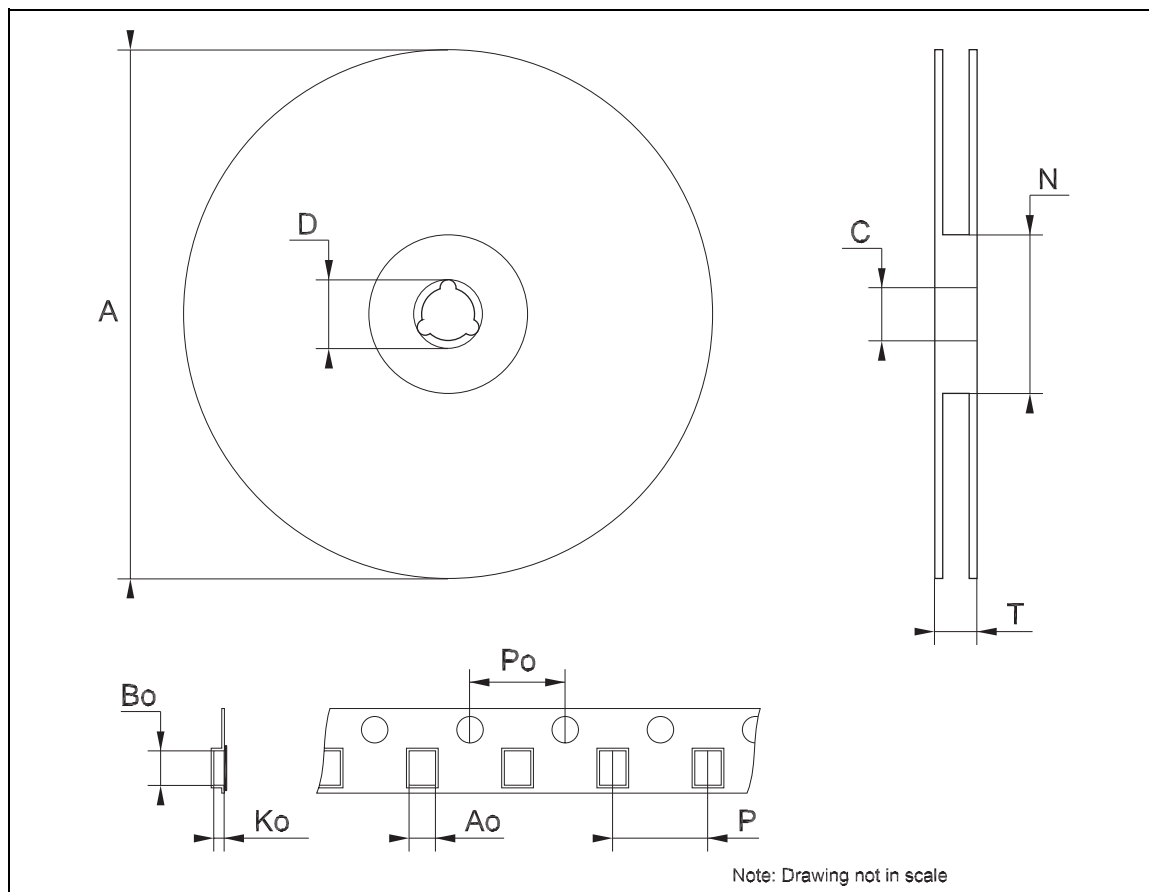



Information furnished is believed to be accurate and reliable. However, STMicroelectronics assumes no responsibility for the consequences of use of such information nor for any infringement of patents or other rights of third parties which may result from its use. No license is granted by implication or otherwise under any patent or patent rights of STMicroelectronics. Specifications mentioned in this publication are subject to change without notice. This publication supersedes and replaces all information previously supplied. STMicroelectronics products are not authorized for use as critical components in life support devices or systems without express written approval of STMicroelectronics.

© The ST logo is a registered trademark of STMicroelectronics

© 2003 STMicroelectronics - Printed in Italy - All Rights Reserved  
STMicroelectronics GROUP OF COMPANIES

Australia - Brazil - Canada - China - Finland - France - Germany - Hong Kong - India - Israel - Italy - Japan - Malaysia - Malta - Morocco  
Singapore - Spain - Sweden - Switzerland - United Kingdom - United States.

© <http://www.st.com>

