



74ACT16541

16-BIT BUS BUFFER WITH 3-STATE OUTPUTS (NON INVERTED)

- HIGH SPEED: $t_{PD} = 4.8ns$ (TYP.) at $V_{CC} = 5V$
- LOW POWER DISSIPATION:
 $I_{CC} = 8\mu A$ (MAX.) at $T_A=25^\circ C$
- COMPATIBLE WITH TTL OUTPUTS
 $V_{IH} = 2V$ (MIN.), $V_{IL} = 0.8V$ (MAX.)
- 50Ω TRANSMISSION LINE DRIVING CAPABILITY
- SYMMETRICAL OUTPUT IMPEDANCE:
 $|I_{OH}| = I_{OL} = 24mA$ (MIN)
- OPERATING VOLTAGE RANGE:
 V_{CC} (OPR) = 4.5V to 5.5V
- IMPROVED LATCH-UP IMMUNITY



TSSOP

ORDER CODES

PACKAGE	TUBE	T & F.
TSSOP		74ACT16541TTR

DESCRIPTION

The 74ACT16541 is an advanced high-speed CMOS 16-BIT BUS BUFFER (3-STATE) fabricated with sub-micron silicon gate and double-layer metal wiring C²MOS technology.

This is composed of two 8-bit sections with separate output-enable signals. For either 8-bit buffers section, the 3 STATE control gate operates as a two input AND such that if either $\overline{nG1}$ and $\overline{nG2}$ are high, all outputs are in the high impedance state.

This device is designed to interface directly High Speed CMOS systems with TTL and NMOS components.

All inputs and outputs are equipped with protection circuits against static discharge, giving them 2KV ESD immunity and transient excess voltage.

PIN CONNECTION

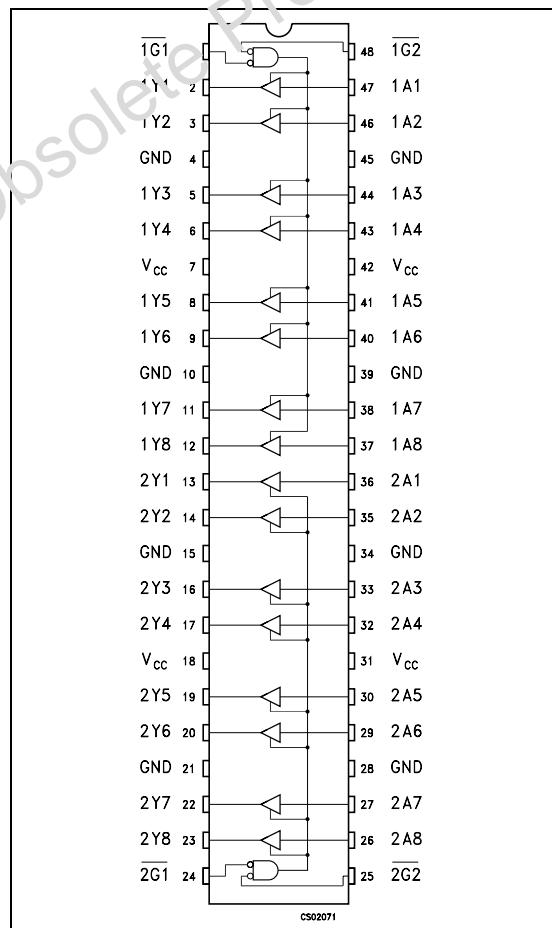

INPUT AND OUTPUT EQUIVALENT CIRCUIT

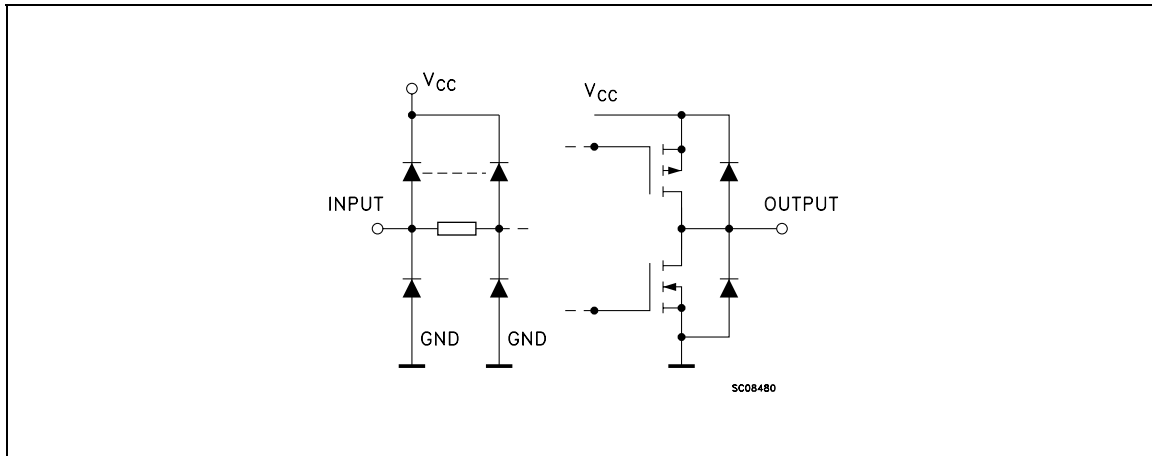

PIN DESCRIPTION

PIN No	SYMBOL	NAME QND FUNCTION
1, 48	1G1, 1G2	Output Enable Inputs
2, 3, 5, 6, 8, 9, 11, 12	1Y1 to 1Y8	Data Outputs
13, 14, 16, 17, 19, 20, 22, 23	2Y1 to 2Y8	Data Outputs
24, 25	2G1, 2G2	Output Enable Inputs
36, 35, 33, 32, 30, 29, 27, 26	2A1 to 2A8	Data Outputs
47, 46, 44, 43, 41, 40, 38, 37	1A1 to 1A8	Data Outputs
4, 10, 15, 21, 28, 34, 39, 45	GND	Ground (0V)
7, 18, 31, 42	V _{CC}	Positive Supply Voltage

IEC LOGIC SYMBOLS

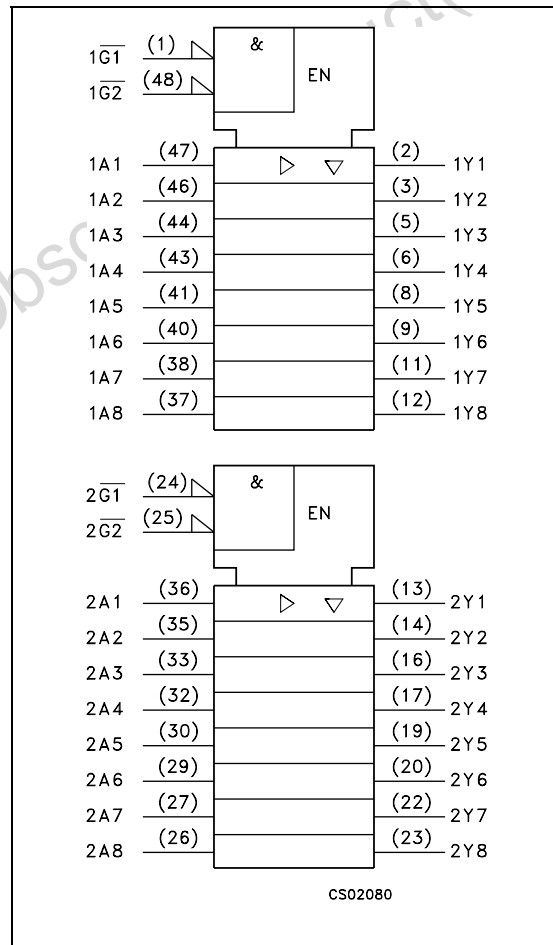

TRUTH TABLE

INPUTS			OUTPUT
$\overline{G1}$	$\overline{G2}$	A _n	Y _n
H	X	X	Z
X	H	X	Z
L	L	H	H
L	L	L	L

X : Don't Care"
Z : High Impedance

ABSOLUTE MAXIMUM RATINGS

Symbol	Parameter	Value	Unit
V_{CC}	Supply Voltage	-0.5 to +7	V
V_I	DC Input Voltage	-0.5 to $V_{CC} + 0.5$	V
V_O	DC Output Voltage	-0.5 to $V_{CC} + 0.5$	V
I_{IK}	DC Input Diode Current	± 20	mA
I_{OK}	DC Output Diode Current	± 20	mA
I_O	DC Output Current	± 50	mA
I_{CC} or I_{GND}	DC V_{CC} or Ground Current	± 400	mA
T_{stg}	Storage Temperature	-65 to +150	°C
T_L	Lead Temperature (10 sec)	300	°C

Absolute Maximum Ratings are those values beyond which damage to the device may occur. Functional operation under these conditions is not implied.

RECOMMENDED OPERATING CONDITIONS

Symbol	Parameter	Value	Unit
V_{CC}	Supply Voltage	4.5 to 5.5	V
V_I	Input Voltage	0 to V_{CC}	V
V_O	Output Voltage	0 to V_{CC}	V
T_{op}	Operating Temperature	-55 to 125	°C
dt/dv	Input Rise and Fall Time $V_{CC} = 4.5$ to $5.5V$ (note 1)	8	ns/V

1) V_{IN} from 0.8V to 2.0V

DC SPECIFICATIONS

Symbol	Parameter	Test Condition		Value						Unit	
		V _{CC} (V)		T _A = 25°C			-40 to 85°C		-55 to 125°C		
				Min.	Typ.	Max.	Min.	Max.	Min.		Max.
V _{IH}	High Level Input Voltage	4.5	V _O = 0.1 V or V _{CC} -0.1V	2.0	1.5		2.0		2.0		V
		5.5		2.0	1.5		2.0		2.0		
V _{IL}	Low Level Input Voltage	4.5	V _O = 0.1 V or V _{CC} -0.1V		1.5	0.8		0.8		0.8	V
		5.5			1.5	0.8		0.8		0.8	
V _{OH}	High Level Output Voltage	4.5	I _O = -50 μA	4.4	4.49		4.4		4.4		V
		5.5	I _O = -50 μA	5.4	5.49		5.4		5.4		
		4.5	I _O = -24 mA	3.86			3.76		3.7		
		5.5	I _O = -24 mA	4.86			4.76		4.7		
V _{OL}	Low Level Output Voltage	4.5	I _O = 50 μA		0.001	0.1		0.1		0.1	V
		5.5	I _O = 50 μA		0.001	0.1		0.1		0.1	
		4.5	I _O = 24 mA			0.36		0.44		0.5	
		5.5	I _O = 24 mA			0.36		0.44		0.5	
I _I	Input Leakage Current	5.5	V _I = V _{CC} or GND			± 0.1		± 1		± 1	μA
I _{OZ}	High Impedance Output Leakage Current	5.5	V _I = V _{IH} or V _{IL} V _O = V _{CC} or GND			± 0.5		± 5		± 5	μA
I _{CCT}	Max I _{CC} /Input	5.5	V _I = V _{CC} - 2.1V		0.6			1.5		1.6	mA
I _{CC}	Quiescent Supply Current	5.5	V _I = V _{CC} or GND			8		80		80	μA
I _{OLD}	Dynamic Output Current (note 1, 2)	5.5	V _{OLD} = 1.65 V max					75		50	mA
I _{OHD}			V _{OHD} = 3.85 V min					-75		-50	mA

1) Maximum test duration 2ms, one output loaded at time

2) Incident wave switching is guaranteed on transmission lines with impedances as low as 50Ω

AC ELECTRICAL CHARACTERISTICS (C_L = 50 pF, R_L = 500 Ω, Input t_r = t_f = 3ns)

Symbol	Parameter	Test Condition		Value						Unit	
		V _{CC} (V)		T _A = 25°C			-40 to 85°C		-55 to 125°C		
				Min.	Typ.	Max.	Min.	Max.	Min.		Max.
t _{PLH}	Propagation Delay Time	5.0(*)			3.1	4.6		9		9	ns
t _{PHL}					4.8	6.8		9.2		9.2	
t _{PZL}	Output Enable Time	5.0(*)			6.5	9.2		11.0		11.0	ns
t _{PZH}					5.7	8.0		10.0		10.0	
t _{PLZ}	Output Disable Time	5.0(*)			6.0	7.9		10.7		10.7	ns
t _{PHZ}					5.3	6.8		9.7		9.7	

(*) Voltage range is 5.0V ± 0.5V

CAPACITIVE CHARACTERISTICS

Symbol	Parameter	Test Condition		Value						Unit	
		V_{CC} (V)		$T_A = 25^\circ\text{C}$			-40 to 85°C		-55 to 125°C		
				Min.	Typ.	Max.	Min.	Max.	Min.		Max.
C_{IN}	Input Capacitance	5.0			3.7						pF
C_{OUT}	Output Capacitance	5.0			13						pF
C_{PD}	Power Dissipation Capacitance (note 1)	5.0	$f_{IN} = 10\text{MHz}$		25						pF

1) C_{PD} is defined as the value of the IC's internal equivalent capacitance which is calculated from the operating current consumption without load. (Refer to Test Circuit). Average operating current can be obtained by the following equation. $I_{CC(opr)} = C_{PD} \times V_{CC} \times f_{IN} + I_{CC}/16$ (per circuit)

TEST CIRCUIT

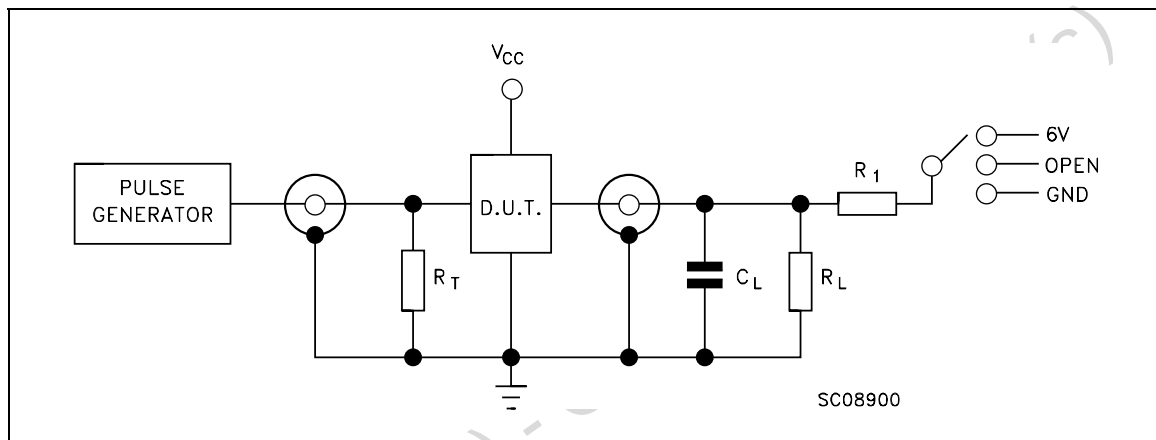

Test	Switch
t_{PLH} , t_{PHL}	Open
t_{PZL} , t_{PLZ}	$2V_{CC}$
t_{PZH} , t_{PHZ}	GND

$C_L = 50\text{pF}$ or equivalent (includes jig and probe capacitance)
 $R_L = R_1 = 500\Omega$ or equivalent
 $R_T = Z_{OUT}$ of pulse generator (typically 50Ω)

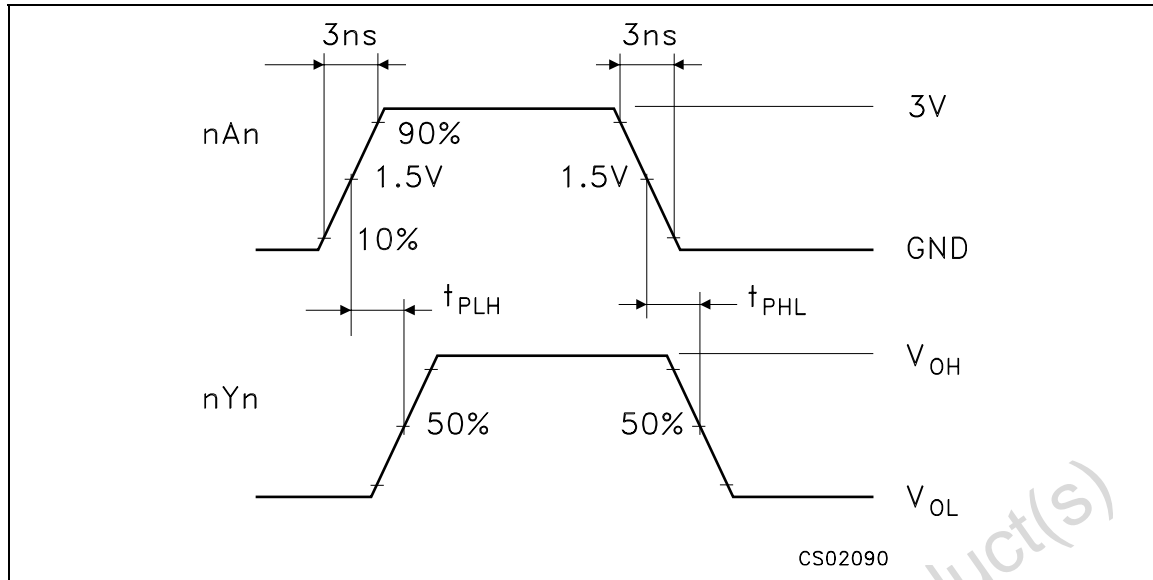
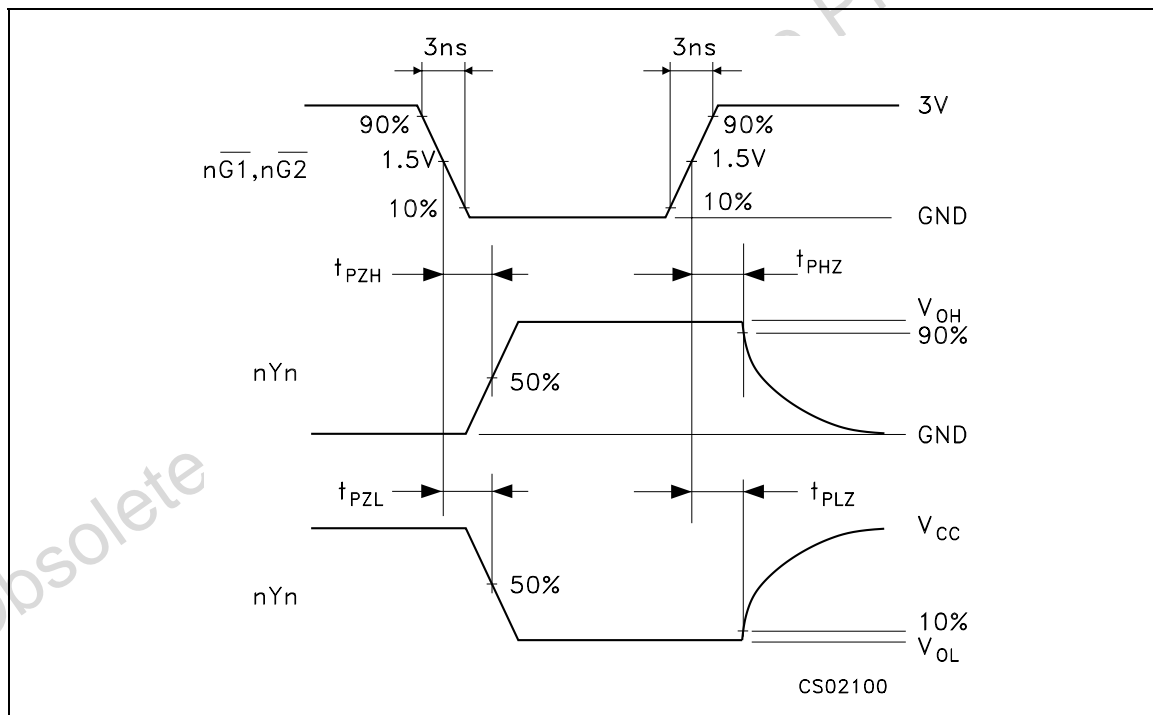
WAVEFORM 1: PROPAGATION DELAYS (f=1MHz; 50% duty cycle)**WAVEFORM 2: OUTPUT ENABLE AND DISABLE TIMES** (f=1MHz; 50% duty cycle)

TSSOP48 MECHANICAL DATA

DIM.	mm.			inch		
	MIN.	TYP	MAX.	MIN.	TYP.	MAX.
A			1.2			0.047
A1	0.05		0.15	0.002		0.006
A2		0.9			0.035	
b	0.17		0.27	0.0067		0.011
c	0.09		0.20	0.0035		0.0079
D	12.4		12.6	0.488		0.496
E		8.1 BSC			0.318 BSC	
E1	6.0		6.2	0.236		0.244
e		0.5 BSC			0.0197 BSC	
K	0°		8°	0°		8°
L	0.50		0.75	0.020		0.030

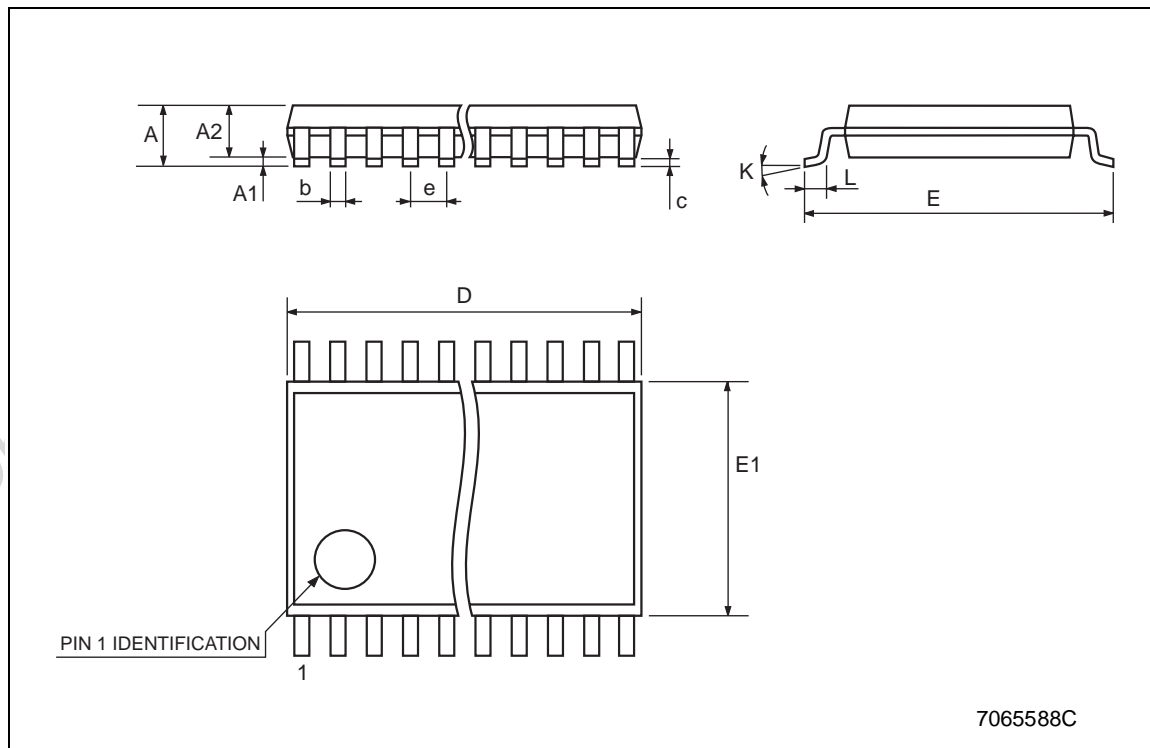

Tape & Reel TSSOP48 MECHANICAL DATA

DIM.	mm.			inch		
	MIN.	TYP.	MAX.	MIN.	TYP.	MAX.
A			330			12.992
C	12.8		13.2	0.504		0.519
D	20.2			0.795		
N	60			2.362		
T			30.4			1.197
Ao	8.7		8.9	0.343		0.350
Bo	13.1		13.3	0.516		0.524
Ko	1.5		1.7	0.059		0.067
Po	3.9		4.1	0.153		0.161
P	11.9		12.1	0.468		0.476

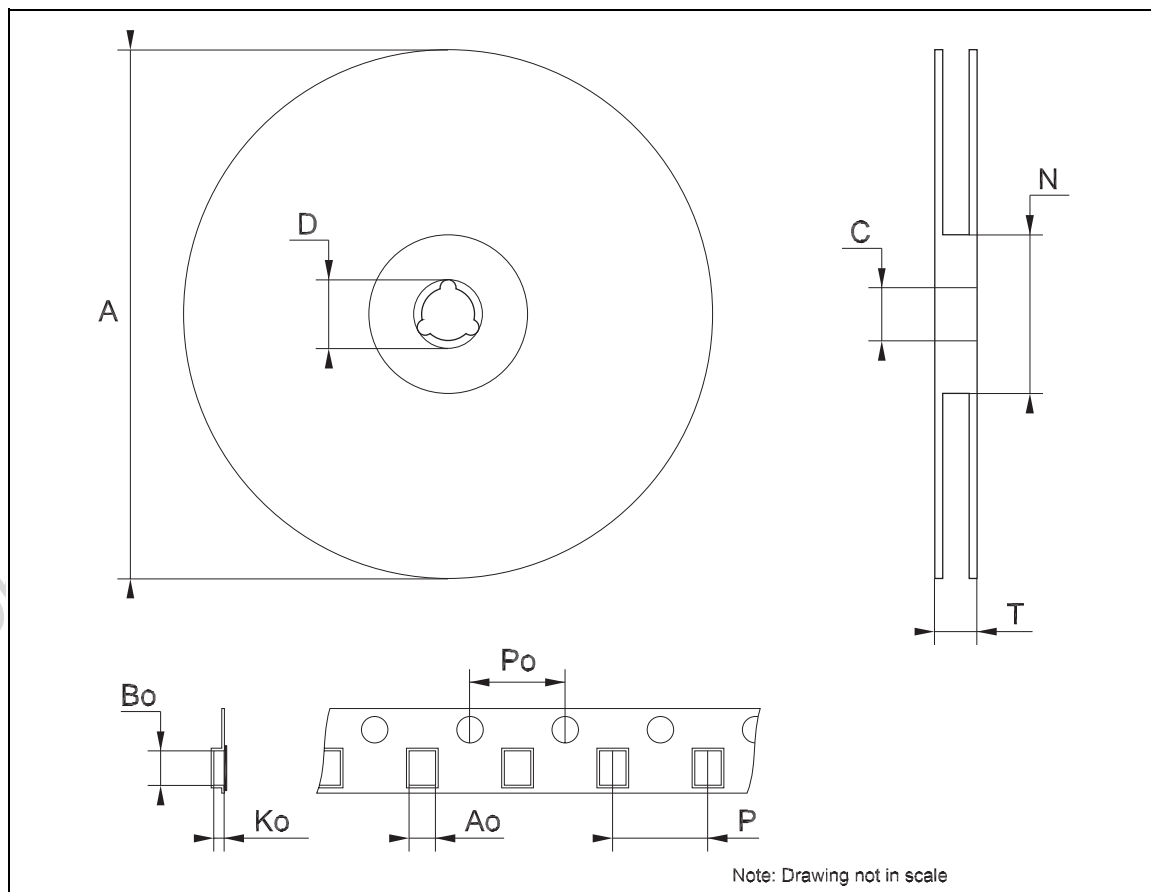

Information furnished is believed to be accurate and reliable. However, STMicroelectronics assumes no responsibility for the consequences of use of such information nor for any infringement of patents or other rights of third parties which may result from its use. No license is granted by implication or otherwise under any patent or patent rights of STMicroelectronics. Specifications mentioned in this publication are subject to change without notice. This publication supersedes and replaces all information previously supplied. STMicroelectronics products are not authorized for use as critical components in life support devices or systems without express written approval of STMicroelectronics.

© The ST logo is a registered trademark of STMicroelectronics

© 2003 STMicroelectronics - Printed in Italy - All Rights Reserved
STMicroelectronics GROUP OF COMPANIES

Australia - Brazil - Canada - China - Finland - France - Germany - Hong Kong - India - Israel - Italy - Japan - Malaysia - Malta - Morocco
Singapore - Spain - Sweden - Switzerland - United Kingdom - United States.

© <http://www.st.com>

