



# 74AC16244

## 16-BIT BUS BUFFER WITH 3-STATE OUTPUTS (NON INVERTED)

- HIGH SPEED:  
 $t_{PD} = 4.5 \text{ ns (TYP.) at } V_{CC} = 5V$
- LOW POWER DISSIPATION:  
 $I_{CC} = 8 \mu\text{A (MAX.) at } T_A = 25^\circ\text{C}$
- HIGH NOISE IMMUNITY:  
 $V_{NIH} = V_{NIL} = 28\% V_{CC} \text{ (MIN.)}$
- POWER DOWN PROTECTION ON INPUTS
- SYMMETRICAL OUTPUT IMPEDANCE:  
 $|I_{OH}| = I_{OL} = 24 \text{ mA (MIN)}$
- BALANCED PROPAGATION DELAYS:  
 $t_{PLH} \approx t_{PHL}$
- OPERATING VOLTAGE RANGE:  
 $V_{CC}(\text{OPR}) = 2V \text{ to } 6V$
- PIN AND FUNCTION COMPATIBLE WITH  
74 SERIES 16244
- IMPROVED LATCH-UP IMMUNITY

### DESCRIPTION

The 74AC16244 is an advanced high-speed CMOS 16-BIT BUS BUFFER (3-STATE) fabricated with sub-micron silicon gate and double-layer metal wiring C<sup>2</sup>MOS technology.

Any  $\overline{nG}$  output control governs four BUS BUFFERS. Output Enable inputs ( $\overline{nG}$ ) tied together give full 16 bit operation.

When  $\overline{nG}$  is LOW, the outputs are enabled. When  $\overline{nG}$  is HIGH, the output are in high impedance state.

The device is designed to be used with 3-state memory address drivers, etc.



TSSOP

### ORDER CODES

PACKAGE	TUBE	T & F.
TSSOP		74AC16244TTR

### PIN CONNECTION

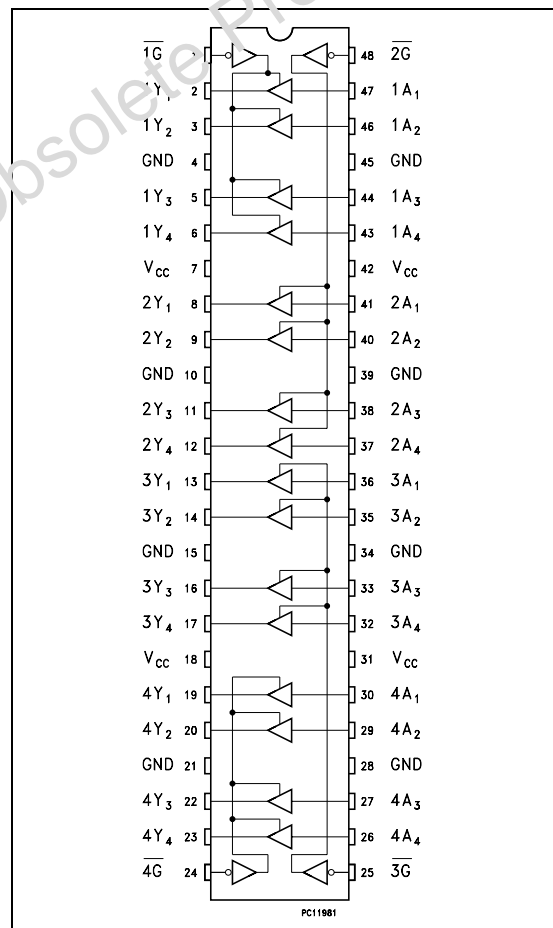

INPUT AND OUTPUT EQUIVALENT CIRCUIT

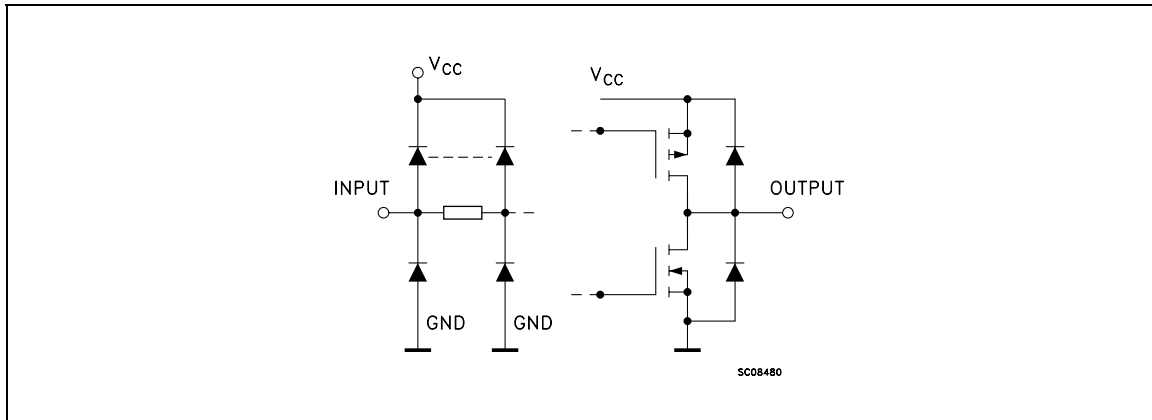

PIN DESCRIPTION

PIN No	SYMBOL	NAME AND FUNCTION
1	1G	Output Enable Input
2, 3, 5, 6	1Y1 to 1Y4	Data Outputs
8, 9, 11, 12	2Y1 to 2Y4	Data Outputs
13, 14, 16, 17	3Y1 to 3Y4	Data Outputs
19, 20, 22, 23	4Y1 to 4Y4	Data Outputs
24	4G	Output Enable Input
25	3G	Output Enable Input
30, 29, 27, 26	4A1 to 4A4	Data Outputs
36, 35, 33, 32	3A1 to 3A4	Data Outputs
41, 40, 38, 37	2A1 to 2A4	Data Outputs
47, 46, 44, 43	1A1 to 1A4	Data Outputs
48	2G	Output Enable Input
4, 10, 15, 21, 28, 34, 39, 45	GND	Ground (0V)
7, 18, 31, 42	V <sub>CC</sub>	Positive Supply Voltage

TRUTH TABLE

INPUTS		OUTPUT
$\bar{G}$	A <sub>n</sub>	Y <sub>n</sub>
L	L	L
L	H	H
H	X	Z

X : Don't Care  
Z : High Impedance

IEC LOGIC SYMBOLS

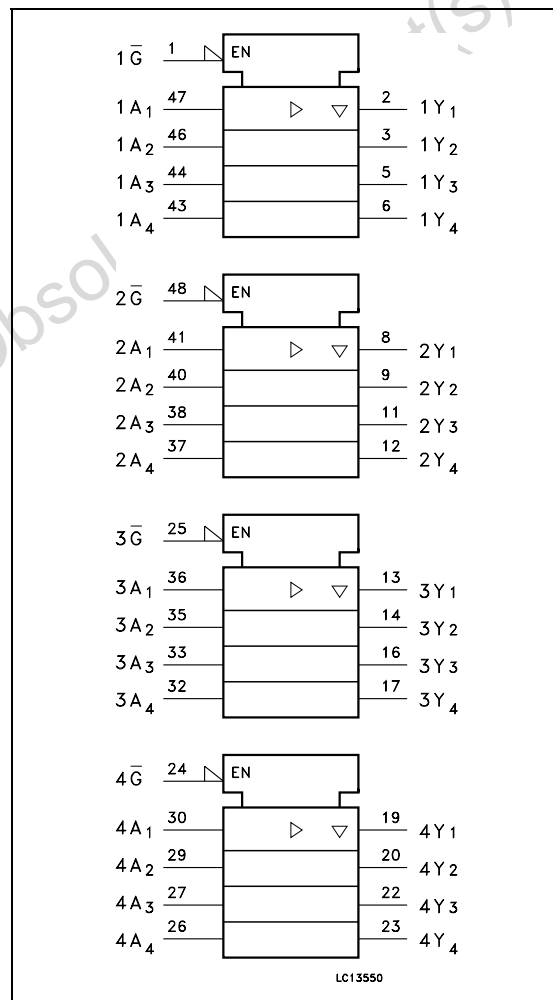

**ABSOLUTE MAXIMUM RATINGS**

Symbol	Parameter	Value	Unit
$V_{CC}$	Supply Voltage	-0.5 to +7.0	V
$V_I$	DC Input Voltage	-0.5 to +7.0	V
$V_O$	DC Output Voltage	-0.5 to $V_{CC} + 0.5$	V
$I_{IK}$	DC Input Diode Current	$\pm 20$	mA
$I_{OK}$	DC Output Diode Current	$\pm 50$	mA
$I_O$	DC Output Current	$\pm 50$	mA
$I_{CC}$ or $I_{GND}$	DC $V_{CC}$ or Ground Current	$\pm 400$	mA
$T_{stg}$	Storage Temperature	-65 to +150	°C
$T_L$	Lead Temperature (10 sec)	300	°C

Absolute Maximum Ratings are those values beyond which damage to the device may occur. Functional operation under these conditions is not implied.

**RECOMMENDED OPERATING CONDITIONS**

Symbol	Parameter	Value	Unit
$V_{CC}$	Supply Voltage	2 to 6	V
$V_I$	Input Voltage	0 to $V_{CC}$	V
$V_O$	Output Voltage	0 to $V_{CC}$	V
$T_{op}$	Operating Temperature	-55 to 125	°C
dt/dv	Input Rise and Fall Time (note 1) $V_{CC} = 3.0, 4.5$ or $5.5$	0 to 8	ns/V

1)  $V_{IN}$  from 30% to 70% of  $V_{CC}$

## DC SPECIFICATIONS

Symbol	Parameter	Test Condition		Value						Unit	
		V <sub>CC</sub> (V)		T <sub>A</sub> = 25 °C			-40 to 85°C		-55 to 125°C		
				Min.	Typ.	Max.	Min.	Max.	Min.		Max.
V <sub>IH</sub>	High Level Input Voltage	3.0	V <sub>O</sub> = 0.1 V or V <sub>CC</sub> -0.1V	2.1	1.5		2.1		2.1		V
		4.5		3.15	2.25		3.15		3.15		
		5.5		3.85	2.75		3.85		3.85		
V <sub>IL</sub>	Low Level Input Voltage	3.0	V <sub>O</sub> = 0.1 V or V <sub>CC</sub> -0.1V		1.5	0.9		0.9		0.9	V
		4.5			2.25	1.35		1.35		1.35	
		5.5			2.75	1.65		1.65		1.65	
V <sub>OH</sub>	High Level Output Voltage	3.0	I <sub>O</sub> = -50 μA	2.9	2.99		2.9		2.9		V
		4.5	I <sub>O</sub> = -50 μA	4.4	4.49		4.4		4.4		
		5.5	I <sub>O</sub> = -50 μA	5.4	5.49		5.4		5.4		
		3.0	I <sub>O</sub> = -12 mA	2.56			2.46		2.46		
		4.5	I <sub>O</sub> = -24 mA	3.86			3.76		3.76		
		5.5	I <sub>O</sub> = -24 mA	4.86			4.76		4.76		
V <sub>OL</sub>	Low Level Output Voltage	3.0	I <sub>O</sub> = 50 μA		0.002	0.1		0.1		0.1	V
		4.5	I <sub>O</sub> = 50 μA		0.001	0.1		0.1		0.1	
		5.5	I <sub>O</sub> = 50 μA		0.001	0.1		0.1		0.1	
		3.0	I <sub>O</sub> = 12 mA			0.36		0.44		0.44	
		4.5	I <sub>O</sub> = 24 mA			0.36		0.44		0.44	
I <sub>I</sub>	Input Leakage Current	5.5	V <sub>I</sub> = V <sub>CC</sub> or GND			± 0.1		± 1		± 1	μA
I <sub>OZ</sub>	High Impedance Output Leakage Current	5.5	V <sub>I</sub> = V <sub>IH</sub> or V <sub>IL</sub> V <sub>O</sub> = V <sub>CC</sub> or GND			± 0.5		± 5		± 5	μA
I <sub>CC</sub>	Quiescent Supply Current	5.5	V <sub>I</sub> = V <sub>CC</sub> or GND			8		80		80	μA

AC ELECTRICAL CHARACTERISTICS (C<sub>L</sub> = 50 pF, R<sub>L</sub> = 500 Ω, Input t<sub>r</sub> = t<sub>f</sub> = 3n)

Symbol	Parameter	Test Condition		Value						Unit	
		V <sub>CC</sub> (V)	C <sub>L</sub> (pF)	T <sub>A</sub> = 25 °C			-40 to 85°C		-55 to 125°C		
				Min.	Typ.	Max.	Min.	Max.	Min.		Max.
t <sub>PLH</sub> t <sub>PHL</sub>	Propagation Delay Time A to Y	3.3 <sup>(*)</sup>			6	8.5		11.5		11.5	ns
		5.0 <sup>(**)</sup>			4.5	7.0		9.0		9.0	
t <sub>PZL</sub> t <sub>PZH</sub>	Output Enable Time	3.3 <sup>(*)</sup>			8	10.5		14.0		14.0	ns
		5.0 <sup>(**)</sup>			5.5	8.0		10.0		10.0	
t <sub>PLZ</sub> t <sub>PHZ</sub>	Output Disable Time	3.3 <sup>(*)</sup>			7.3	9.0		11.5		11.5	ns
		5.0 <sup>(**)</sup>			5.5	8.0		14.0		14.0	

(\*) Voltage range is 3.3V ± 0.3V

(\*\*) Voltage range is 5.0V ± 0.5V

## CAPACITIVE CHARACTERISTICS

Symbol	Parameter	Test Condition		Value						Unit	
		$V_{CC}$ (V)		$T_A = 25^\circ\text{C}$			$-40 \text{ to } 85^\circ\text{C}$		$-55 \text{ to } 125^\circ\text{C}$		
				Min.	Typ.	Max.	Min.	Max.	Min.		Max.
$C_{IN}$	Input Capacitance				7	10		10		10	pF
$C_{OUT}$	Output Capacitance				14						pF
$C_{PD}$	Power Dissipation Capacitance (note 1)	5.0	$f_{IN} = 10\text{MHz}$		25						pF

1)  $C_{PD}$  is defined as the value of the IC's internal equivalent capacitance which is calculated from the operating current consumption without load. (Refer to Test Circuit). Average operating current can be obtained by the following equation.  $I_{CC(oper)} = C_{PD} \times V_{CC} \times f_{IN} + I_{CC}/16$  (per Latch)

## TEST CIRCUIT

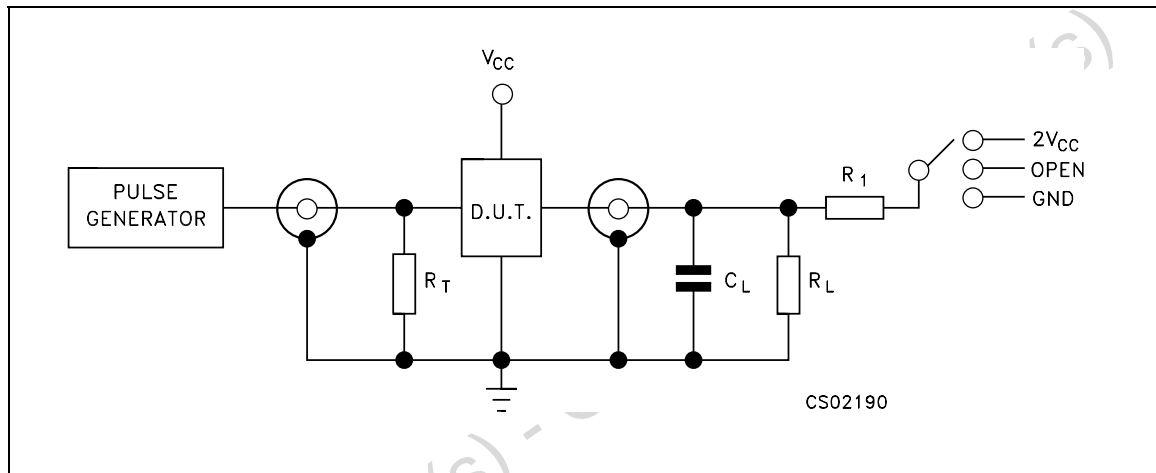

TEST	SWITCH
$t_{PLH}, t_{PHL}$	Open
$t_{PZL}, t_{PLZ}$	$V_{CC}$
$t_{PZH}, t_{PHZ}$	GND

$C_L = 50 \text{ pF}$  or equivalent (includes jig and probe capacitance)

$R_L = R_1 = 500\Omega$  or equivalent

$R_T = Z_{OUT}$  of pulse generator (typically  $50\Omega$ )

WAVEFORM 1: PROPAGATION DELAYS (f=1MHz; 50% duty cycle)

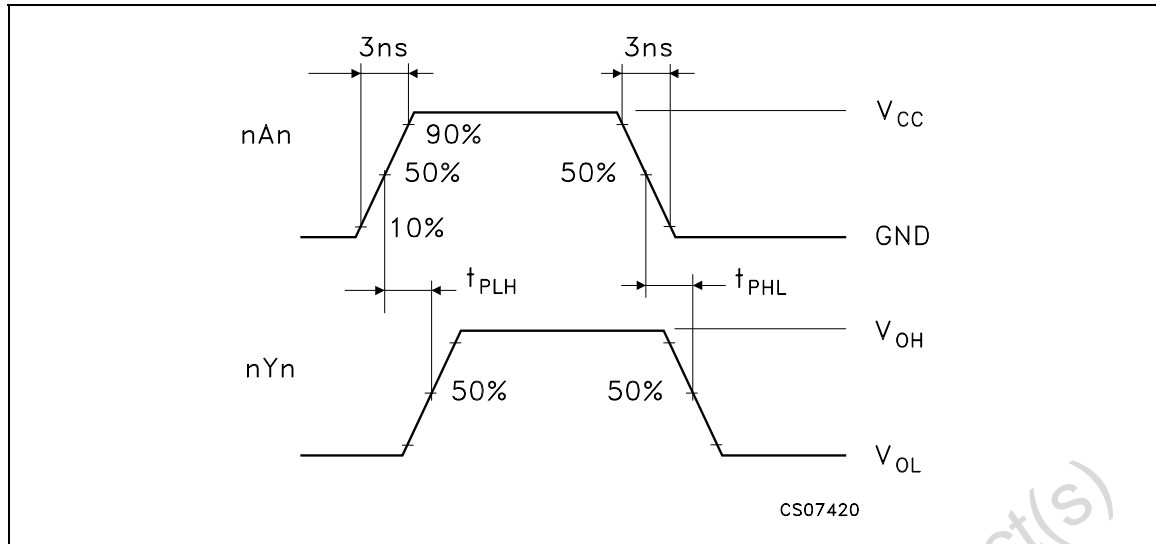

WAVEFORM 2: OUTPUT ENABLE AND DISABLE TIME (f=1MHz; 50% duty cycle)

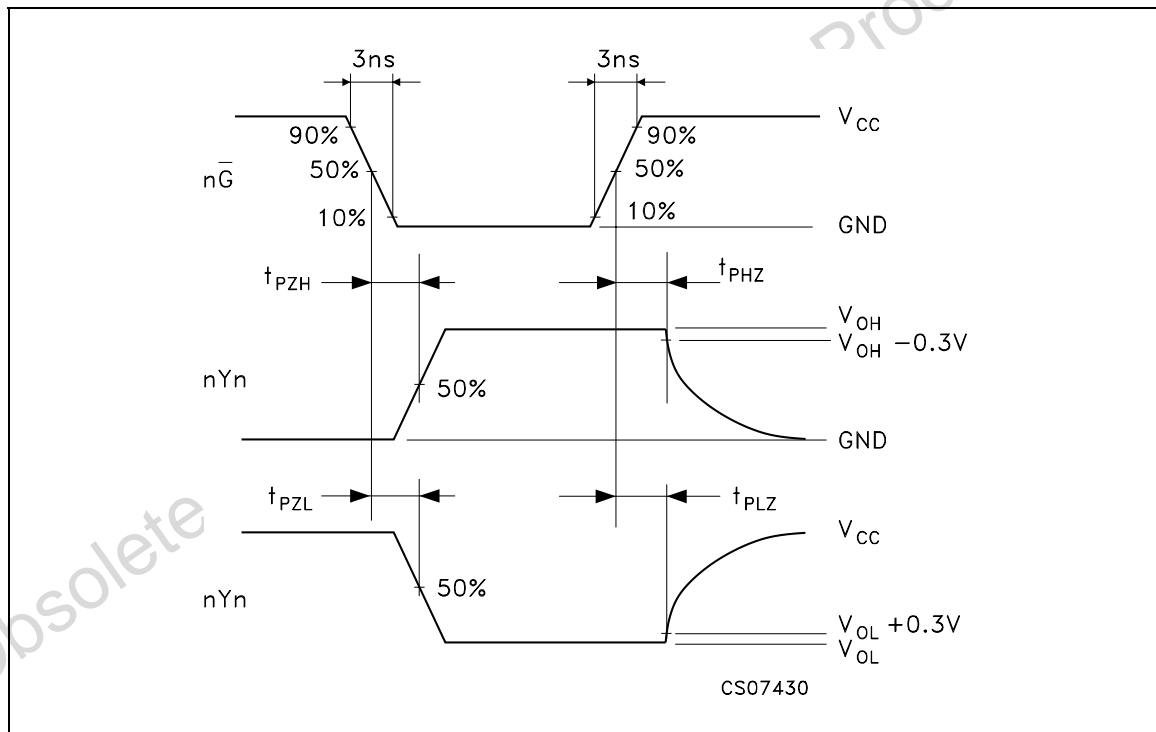

## TSSOP48 MECHANICAL DATA

DIM.	mm.			inch		
	MIN.	TYP	MAX.	MIN.	TYP.	MAX.
A			1.2			0.047
A1	0.05		0.15	0.002		0.006
A2		0.9			0.035	
b	0.17		0.27	0.0067		0.011
c	0.09		0.20	0.0035		0.0079
D	12.4		12.6	0.488		0.496
E		8.1 BSC			0.318 BSC	
E1	6.0		6.2	0.236		0.244
e		0.5 BSC			0.0197 BSC	
K	0°		8°	0°		8°
L	0.50		0.75	0.020		0.030

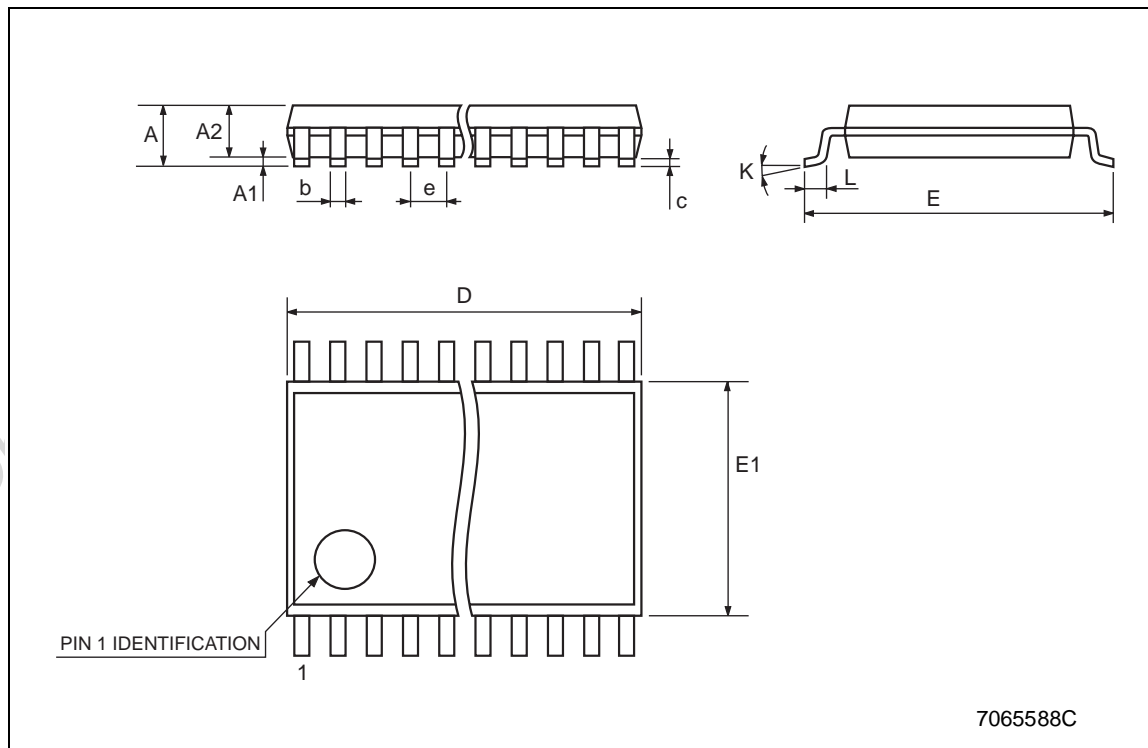

7065588C

## Tape &amp; Reel TSSOP48 MECHANICAL DATA

DIM.	mm.			inch		
	MIN.	TYP.	MAX.	MIN.	TYP.	MAX.
A			330			12.992
C	12.8		13.2	0.504		0.519
D	20.2			0.795		
N	60			2.362		
T			30.4			1.197
Ao	8.7		8.9	0.343		0.350
Bo	13.1		13.3	0.516		0.524
Ko	1.5		1.7	0.059		0.067
Po	3.9		4.1	0.153		0.161
P	11.9		12.1	0.468		0.476

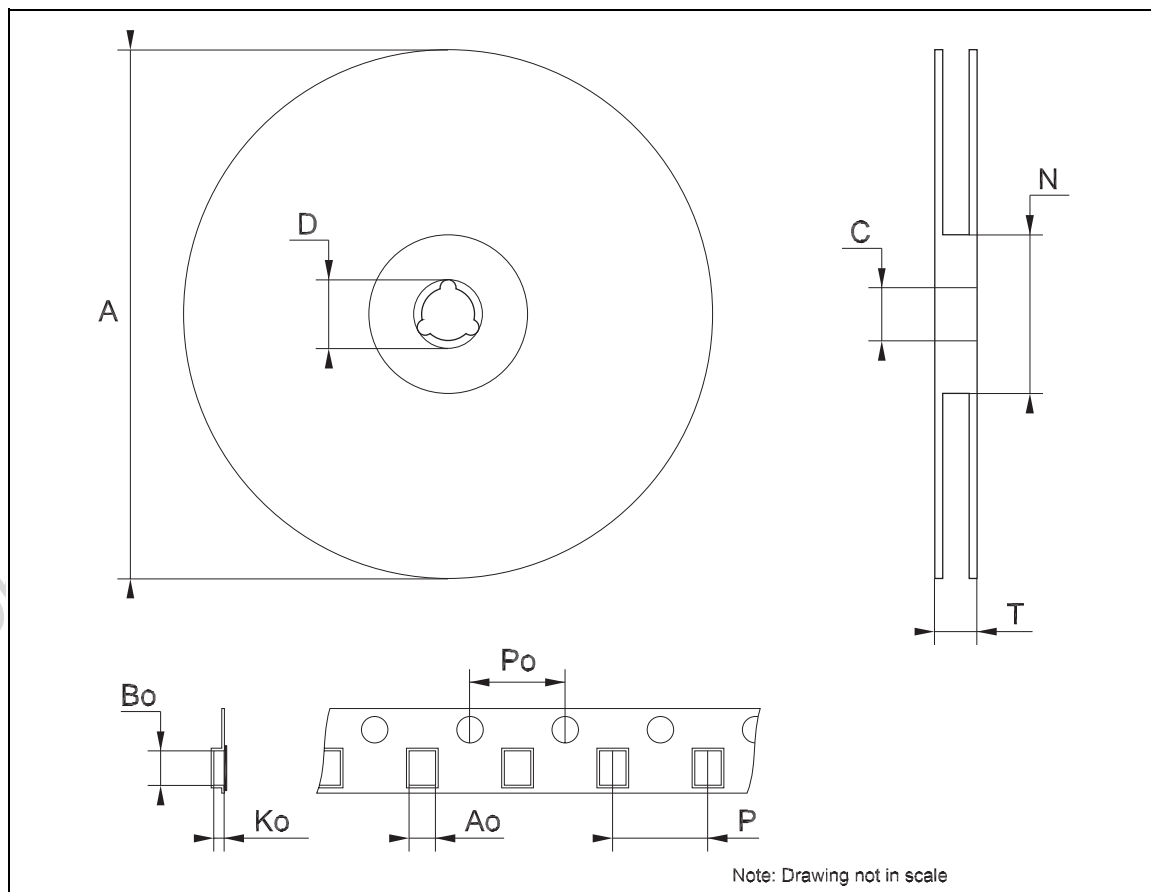



Information furnished is believed to be accurate and reliable. However, STMicroelectronics assumes no responsibility for the consequences of use of such information nor for any infringement of patents or other rights of third parties which may result from its use. No license is granted by implication or otherwise under any patent or patent rights of STMicroelectronics. Specifications mentioned in this publication are subject to change without notice. This publication supersedes and replaces all information previously supplied. STMicroelectronics products are not authorized for use as critical components in life support devices or systems without express written approval of STMicroelectronics.

© The ST logo is a registered trademark of STMicroelectronics

© 2003 STMicroelectronics - Printed in Italy - All Rights Reserved  
STMicroelectronics GROUP OF COMPANIES

Australia - Brazil - Canada - China - Finland - France - Germany - Hong Kong - India - Israel - Italy - Japan - Malaysia - Malta - Morocco  
Singapore - Spain - Sweden - Switzerland - United Kingdom - United States.

© <http://www.st.com>

