

LM1877

Dual Audio Power Amplifier

General Description

The LM1877 is a monolithic dual power amplifier designed to deliver 2W/channel continuous into 8Ω loads. The LM1877 is designed to operate with a low number of external components, and still provide flexibility for use in stereo phonographs, tape recorders and AM-FM stereo receivers, etc. Each power amplifier is biased from a common internal regulator to provide high power supply rejection, and output Q point centering. The LM1877 is internally compensated for all gains greater than 10.

Features

- 2W/channel
- -65 dB ripple rejection, output referred
- -65 dB channel separation, output referred

- Wide supply range, 6V–24V
- Very low cross-over distortion
- Low audio band noise
- AC short circuit protected
- Internal thermal shutdown

Applications

- Multi-channel audio systems
- Stereo phonographs
- Tape recorders and players
- AM-FM radio receivers
- Servo amplifiers
- Intercom systems
- Automotive products

Connection Diagram

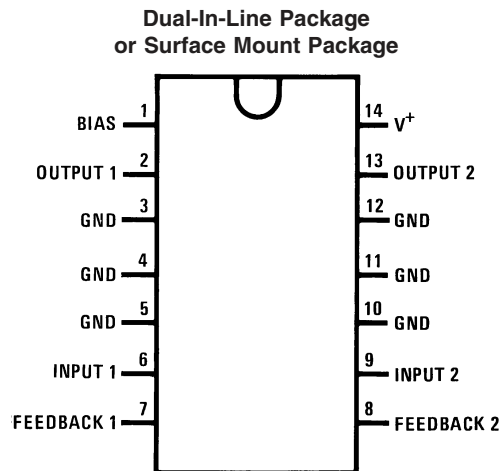

00791301

Top View
Order Number LM1877M-9 or LM1877N-9
See NS Package Number M14B or N14A

Equivalent Schematic Diagram

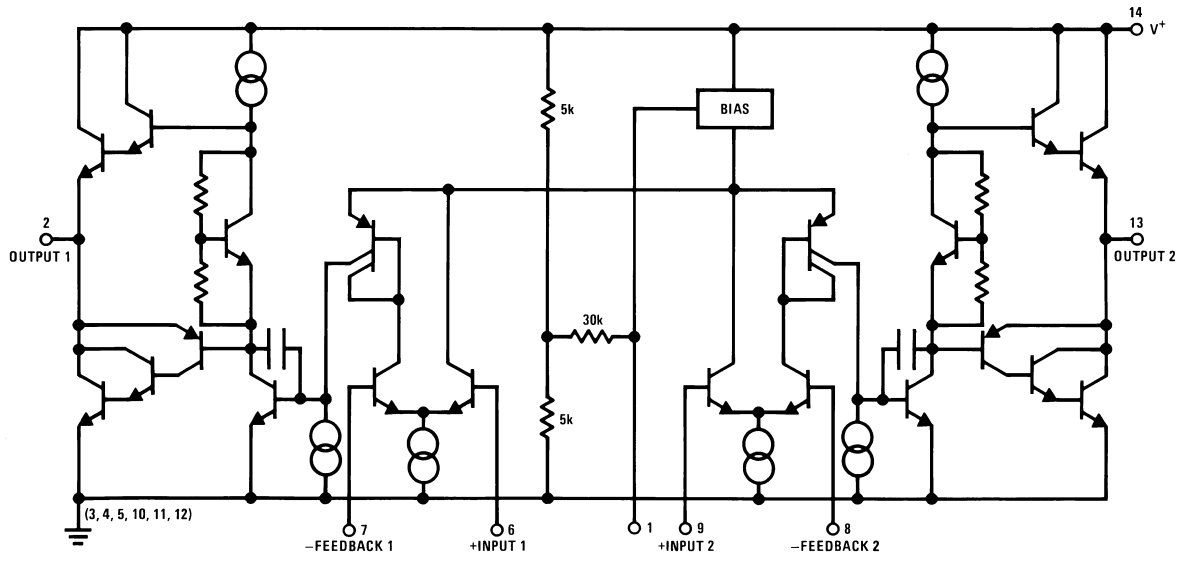

00791302

Absolute Maximum Ratings (Note 1)

If Military/Aerospace specified devices are required, please contact the National Semiconductor Sales Office/Distributors for availability and specifications.

Supply Voltage	26V
Input Voltage	±0.7V
Operating Temperature	0°C to +70°C
Storage Temperature	-65°C to +150°C
Junction Temperature	150°C
Lead Temperature	
N-Package Soldering (10 sec.)	260°C

M-Package Infared (15 sec.)	220°C
M-Package Vapor Phase (60 sec.)	215°C
Thermal Resistance	
θ_{JC} (N-Package)	30°C/W
θ_{JA} (N-Package)	79°C/W
θ_{JC} (M-Package)	27°C/W
θ_{JA} (M-Package)	114°C/W

Note 1: Absolute Maximum Ratings indicate limits beyond which damage to the device may occur. Operating Ratings indicate conditions for which the device is functional, but do not guarantee specific performance limits.

Electrical Characteristics

$V_S = 20V$, $T_A = 25^\circ C$, (Note 2) $R_L = 8\Omega$, $A_V = 50$ (34 dB) unless otherwise specified

Parameter	Conditions	Min	Typ	Max	Units
Total Supply Current	$P_O = 0W$		25	50	mA
Output Power LM1877	THD = 10% $V_S = 20V$, $R_L = 8\Omega$ $V_S = 12V$, $R_L = 8\Omega$	2.0	1.3		W/Ch W/Ch
Total Harmonic Distortion LM1877	$f = 1$ kHz, $V_S = 14V$				
	$P_O = 50$ mW/Channel		0.075		%
	$P_O = 500$ mW/Channel		0.045		%
	$P_O = 1$ W/Channel		0.055		%
Output Swing	$R_L = 8\Omega$		$V_S - 6$		Vp-p
Channel Separation	$C_F = 50$ μF , $C_{IN} = 0.1$ μF , $f = 1$ kHz, Output Referred				
	$V_S = 20V$, $V_O = 4$ Vrms	-50	-70		dB
	$V_S = 7V$, $V_O = 0.5$ Vrms		-60		dB
PSRR Power Supply Rejection Ratio	$C_F = 50$ μF , $C_{IN} = 0.1$ μF , $f = 120$ Hz, Output Referred				
	$V_S = 20V$, $V_{RIPPLE} = 1$ Vrms	-50	-65		dB
	$V_S = 7V$, $V_{RIPPLE} = 0.5$ Vrms		-40		dB
Noise	Equivalent Input Noise				
	$R_S = 0$, $C_{IN} = 0.1$ μF , BW = 20 Hz–20 kHz, Output Noise Wideband		2.5		μV
	$R_S = 0$, $C_N = 0.1$ μF , $A_V 200$		0.80		mV
Open Loop Gain	$R_S = 0$, $f = 100$ kHz, $R_L = 8\Omega$		70		dB
Input Offset Voltage			15		mV
Input Bias Current			50		nA
Input Impedance	Open Loop		4		M Ω
DC Output Level	$V_S = 20V$	9	10	11	V
Slew Rate			2.0		V/ μs
Power Bandwidth			65		kHz
Current Limit			1.0		A

Note 2: For operation at ambient temperature greater than 25°C, the LM1877 must be derated based on a maximum 150°C junction temperature.

Typical Performance Characteristics

Device Dissipation vs Ambient Temperature

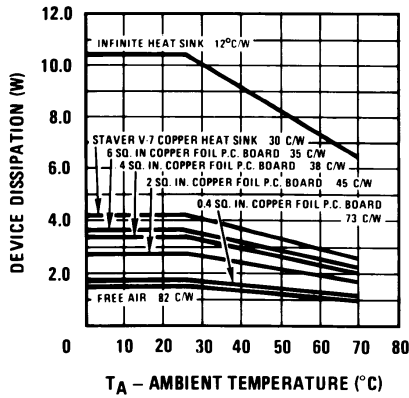

00791310

Power Supply Rejection Ratio (Referred to the Output) vs Frequency

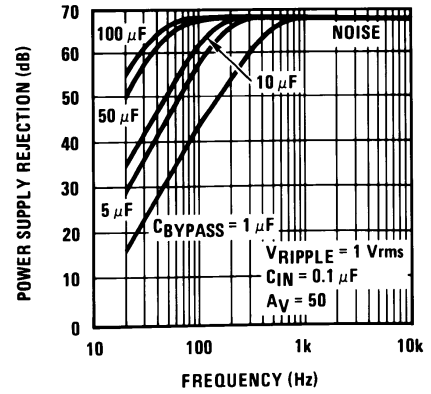

00791311

Power Supply Rejection Ratio (Referred to the Output) vs Frequency

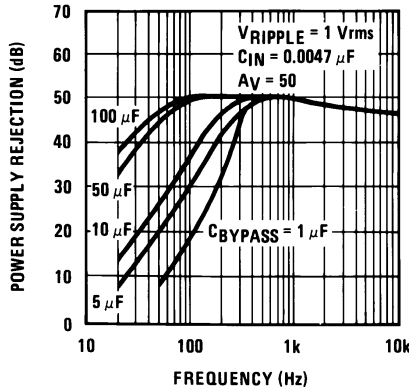

00791312

Power Supply Rejection Ratio (Referred to the Output) vs Supply Voltage

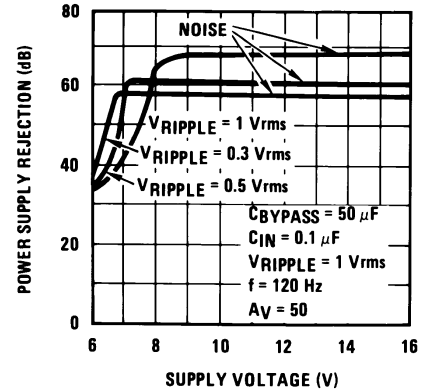

00791313

Channel Separation (Referred to the Output) vs Frequency

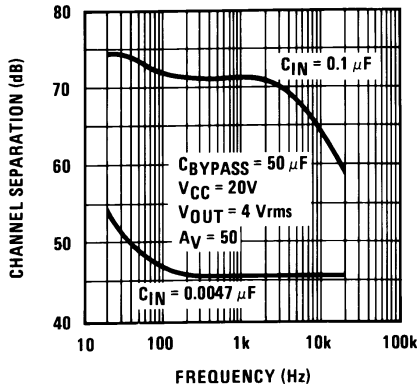

00791314

Channel Separation (Referred to the Output) vs Frequency

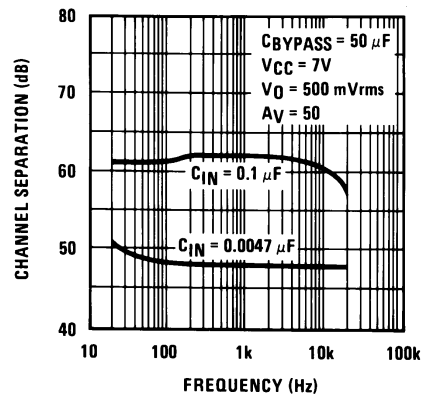

00791315

Typical Performance Characteristics (Continued)

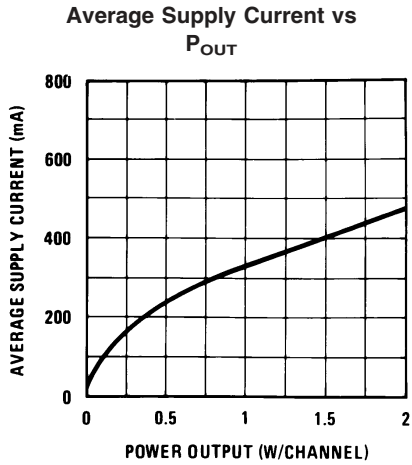

00791316

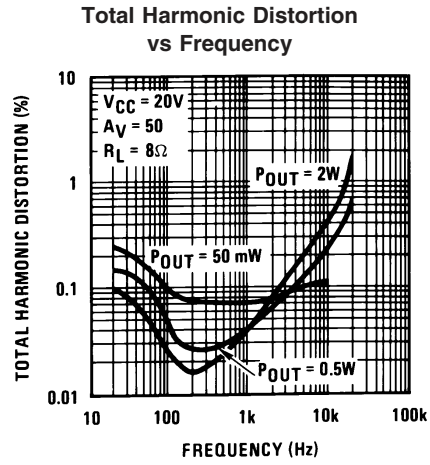

00791317

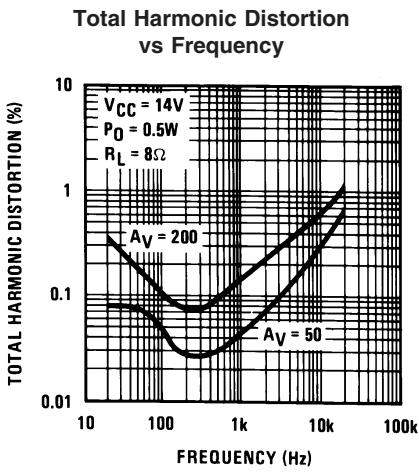

00791318

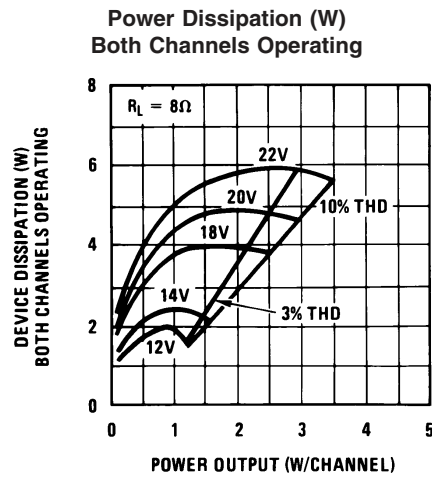

00791319

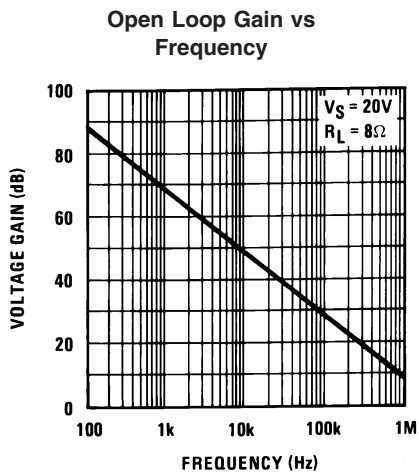

00791320

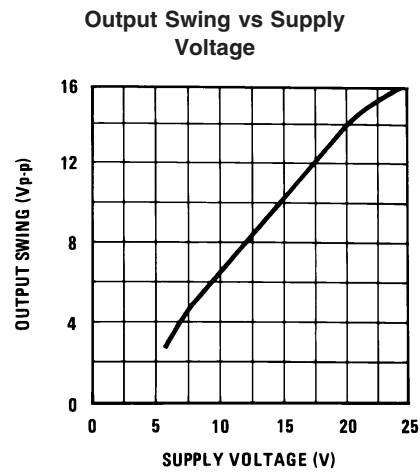

00791321

Typical Applications

Stereo Phonograph Amplifier with Bass Tone Control

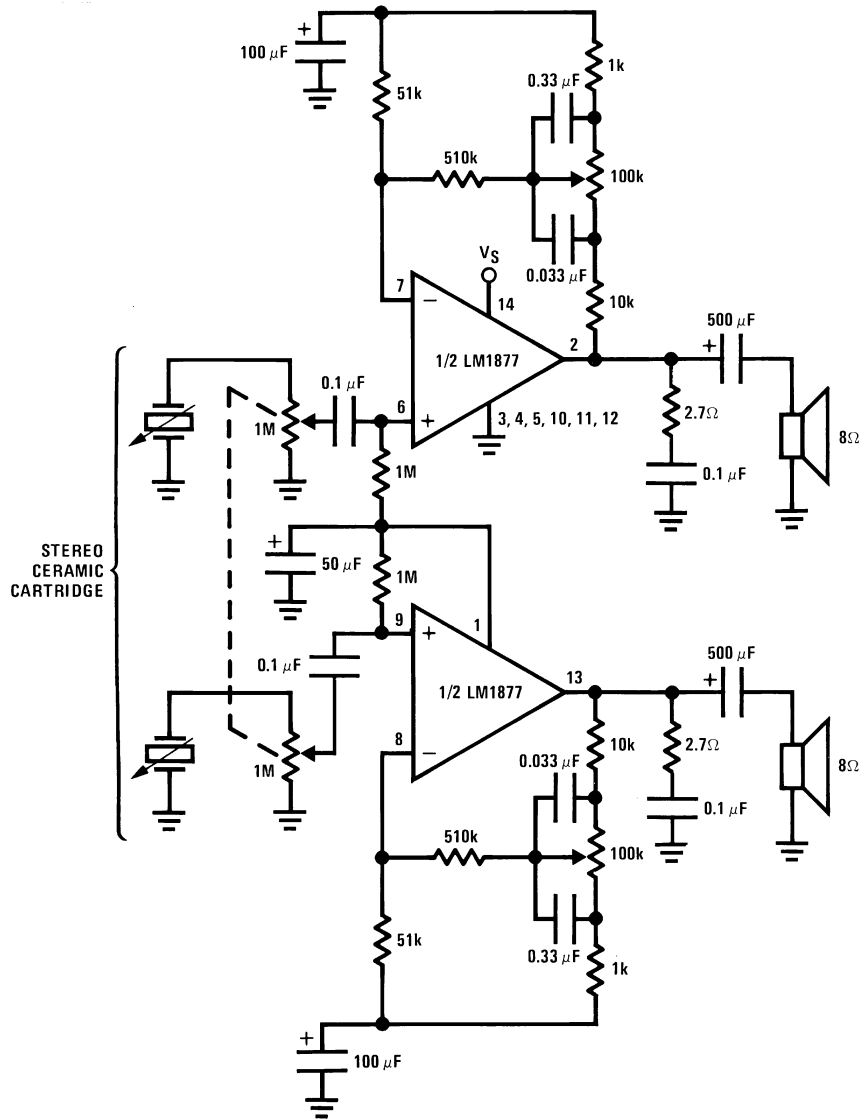

00791304

Frequency Response of Bass Tone Control

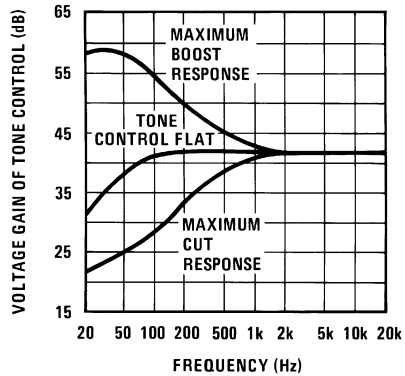

00791305

Inverting Unity Gain Amplifier

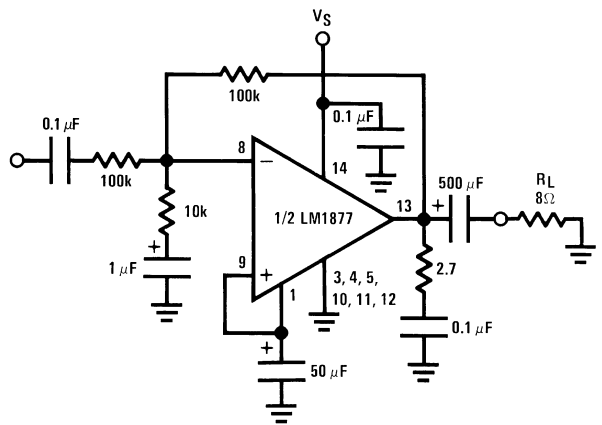

00791306

Typical Applications (Continued)

Stereo Amplifier with $A_V = 200$

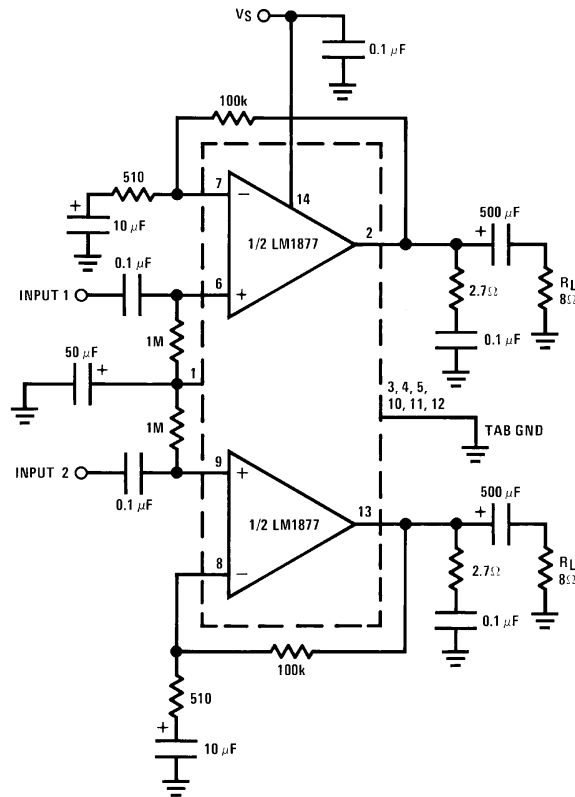

00791307

Non-Inverting Amplifier Using Split Supply

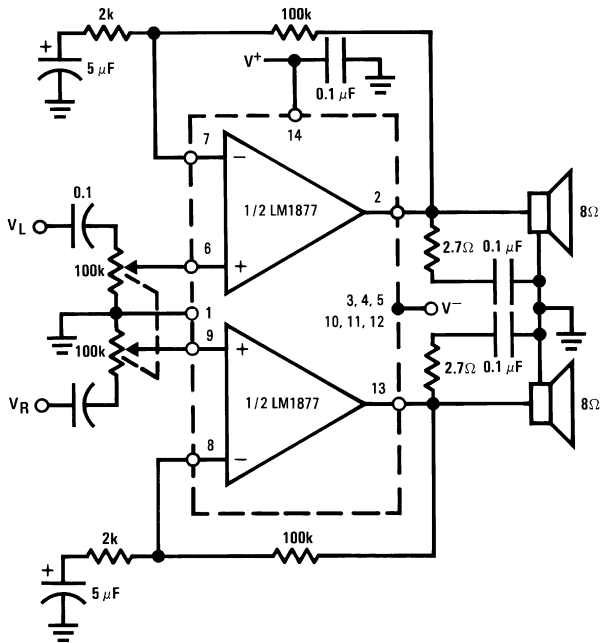

00791308

Typical Split Supply

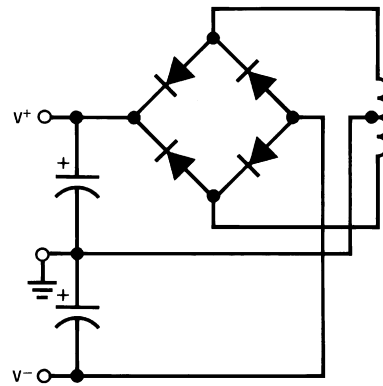

00791309

Physical Dimensions inches (millimeters) unless otherwise noted

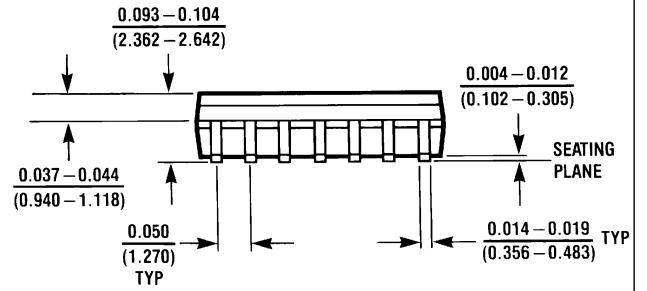
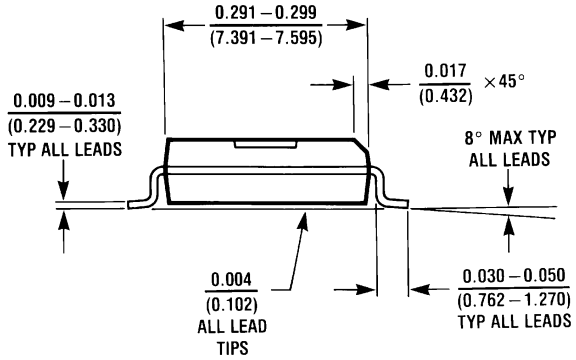
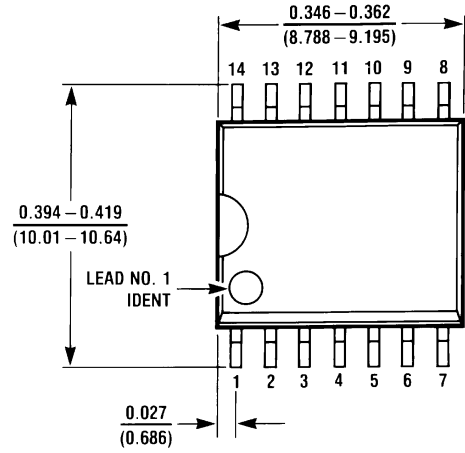

M14B (REV D)

Molded SOIC Package (M)
Order Number LM1877M-9
NS Package Number M14B

Physical Dimensions inches (millimeters) unless otherwise noted (Continued)

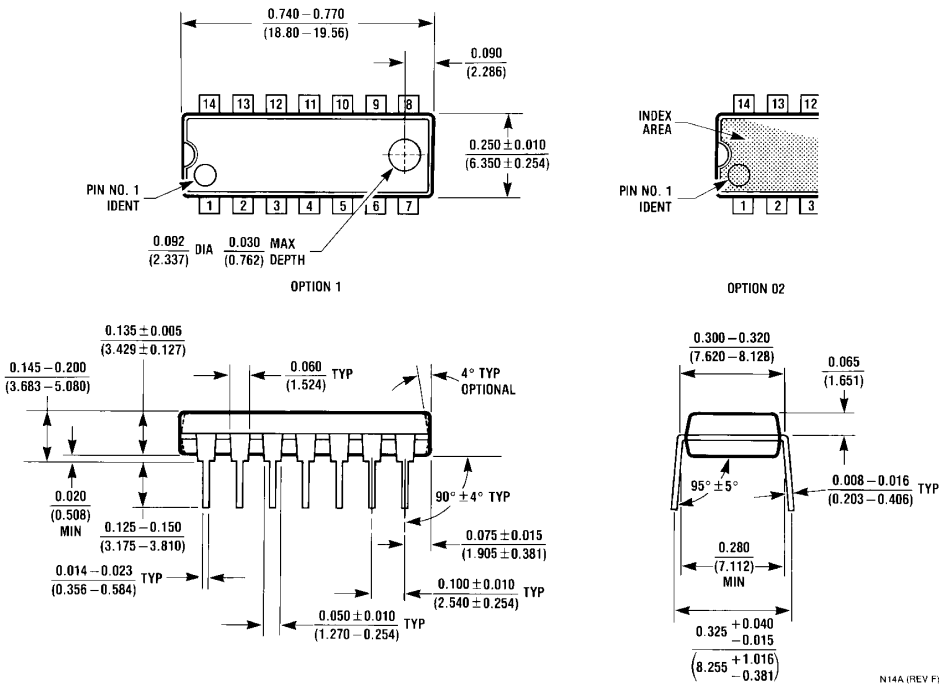

**Molded Dual-In-Line Package (N)
Order Number LM1877N-9
NS Package Number N14A**

National does not assume any responsibility for use of any circuitry described, no circuit patent licenses are implied and National reserves the right at any time without notice to change said circuitry and specifications.

For the most current product information visit us at www.national.com.

LIFE SUPPORT POLICY

NATIONAL'S PRODUCTS ARE NOT AUTHORIZED FOR USE AS CRITICAL COMPONENTS IN LIFE SUPPORT DEVICES OR SYSTEMS WITHOUT THE EXPRESS WRITTEN APPROVAL OF THE PRESIDENT AND GENERAL COUNSEL OF NATIONAL SEMICONDUCTOR CORPORATION. As used herein:

1. Life support devices or systems are devices or systems which, (a) are intended for surgical implant into the body, or (b) support or sustain life, and whose failure to perform when properly used in accordance with instructions for use provided in the labeling, can be reasonably expected to result in a significant injury to the user.
2. A critical component is any component of a life support device or system whose failure to perform can be reasonably expected to cause the failure of the life support device or system, or to affect its safety or effectiveness.

BANNED SUBSTANCE COMPLIANCE

National Semiconductor certifies that the products and packing materials meet the provisions of the Customer Products Stewardship Specification (CSP-9-111C2) and the Banned Substances and Materials of Interest Specification (CSP-9-111S2) and contain no "Banned Substances" as defined in CSP-9-111S2.



National Semiconductor
Americas Customer Support Center
Email: new.feedback@nsc.com
Tel: 1-800-272-9959

National Semiconductor
Europe Customer Support Center
Fax: +49 (0) 180-530 85 86
Email: europe.support@nsc.com
Deutsch Tel: +49 (0) 69 9508 6208
English Tel: +44 (0) 870 24 0 2171
Français Tel: +33 (0) 1 41 91 8790

National Semiconductor
Asia Pacific Customer Support Center
Email: ap.support@nsc.com

National Semiconductor
Japan Customer Support Center
Fax: 81-3-5639-7507
Email: jpn.feedback@nsc.com
Tel: 81-3-5639-7560

www.national.com