



74ALVCH16244

LOW VOLTAGE CMOS 16-BIT BUS BUFFER (3-STATE) WITH 3.6V TOLERANT INPUTS AND OUTPUTS

- 3.6V TOLERANT INPUTS AND OUTPUTS
- HIGH SPEED :
 $t_{PD} = 3.0 \text{ ns (MAX.) at } V_{CC} = 3.0 \text{ to } 3.6\text{V}$
 $t_{PD} = 3.7 \text{ ns (MAX.) at } V_{CC} = 2.3 \text{ to } 2.7\text{V}$
 $t_{PD} = 5.1 \text{ ns (MAX.) at } V_{CC} = 1.65\text{V}$
- POWER DOWN PROTECTION ON INPUTS AND OUTPUTS
- SYMMETRICAL OUTPUT IMPEDANCE:
 $I_{OH} = I_{OL} = 24\text{mA (MIN) at } V_{CC} = 3.0\text{V}$
 $I_{OH} = I_{OL} = 12\text{mA (MIN) at } V_{CC} = 2.3\text{V}$
 $I_{OH} = I_{OL} = 4\text{mA (MIN) at } V_{CC} = 1.65\text{V}$
- OPERATING VOLTAGE RANGE:
 $V_{CC(OPR)} = 1.65\text{V to } 3.6\text{V}$
- BUS HOLD PROVIDED ON DATA INPUTS
- PIN AND FUNCTION COMPATIBLE WITH 74 SERIES 16244
- LATCH-UP PERFORMANCE EXCEEDS 300mA (JESD 17)
- ESD PERFORMANCE:
HBM > 2000V (MIL STD 883 method 3015);
MM > 200V

DESCRIPTION

The 74ALVCH16244 is a low voltage CMOS 16 BIT BUS BUFFER (NON INVERTED) fabricated with sub-micron silicon gate and five-layer metal wiring C²MOS technology. It is ideal for low power and very high speed 1.65 to 3.6V applications; it can be interfaced to 3.6V signal environment for both inputs and outputs.

Any \overline{nG} output control governs four BUS BUFFERS. Output Enable input (\overline{nG}) tied together gives full 16-bit operation.

When \overline{nG} is LOW, the outputs are enabled. When \overline{nG} is HIGH, the output are in high impedance state.

Active bus-hold circuitry is provided to hold unused or floating data inputs at a valid logic level. This device is designed to be used with 3 state memory address drivers, etc.

All inputs and outputs are equipped with protection circuits against static discharge, giving them 2KV ESD immunity and transient excess voltage.



ORDER CODES

| PACKAGE | TUBE | T & R |
|---------|------|-----------------|
| TSSOP | | 74ALVCH16244TTR |

PIN CONNECTION

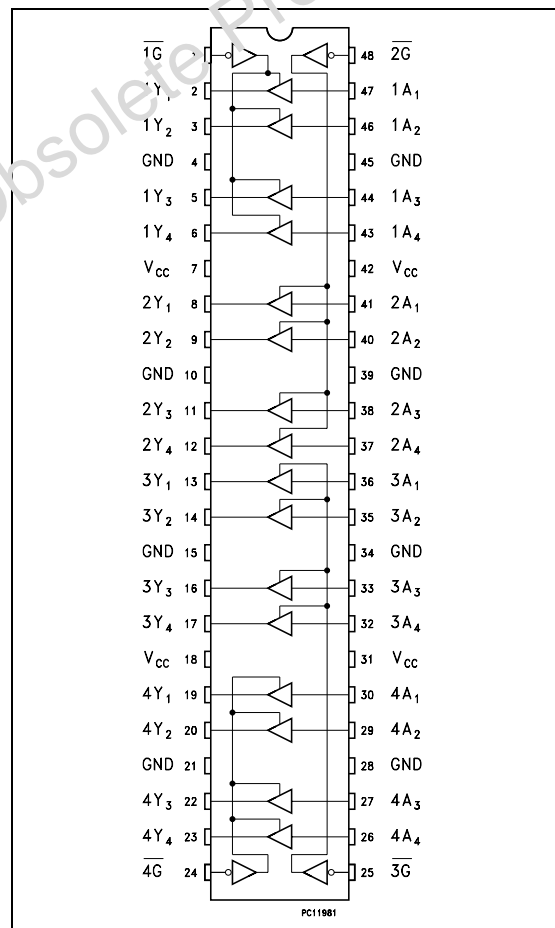

INPUT AND OUTPUT EQUIVALENT CIRCUIT

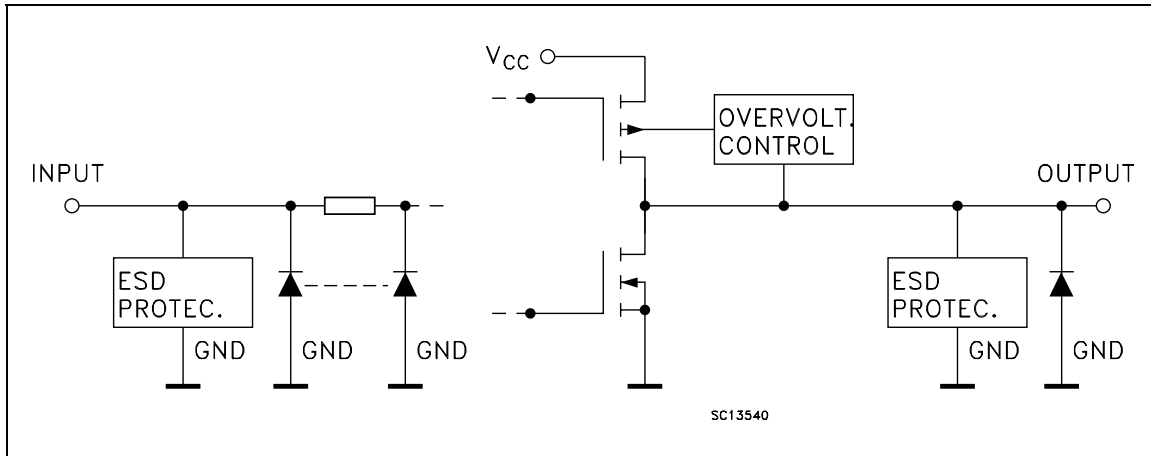

PIN DESCRIPTION

| PIN No | SYMBOL | NAME AND FUNCTION |
|-------------------------------|-----------------|-------------------------|
| 1 | 1 \bar{G} | Output Enable Input |
| 2, 3, 5, 6 | 1Y1 to 1Y4 | Data Outputs |
| 8, 9, 11, 12 | 2Y1 to 2Y4 | Data Outputs |
| 13, 14, 16, 17 | 3Y1 to 3Y4 | Data Outputs |
| 19, 20, 22, 23 | 4Y1 to 4Y4 | Data Outputs |
| 24 | 4G | Output Enable Input |
| 25 | 3 \bar{G} | Output Enable Input |
| 30, 29, 27, 26 | 4A1 to 4A4 | Data Outputs |
| 36, 35, 33, 32 | 3A1 to 3A4 | Data Outputs |
| 41, 40, 38, 37 | 2A1 to 2A4 | Data Outputs |
| 47, 46, 44, 43 | 1A1 to 1A4 | Data Outputs |
| 48 | 2G | Output Enable Input |
| 4, 10, 15, 21, 28, 34, 39, 45 | GND | Ground (0V) |
| 7, 18, 31, 42 | V _{CC} | Positive Supply Voltage |

IEC LOGIC SYMBOLS

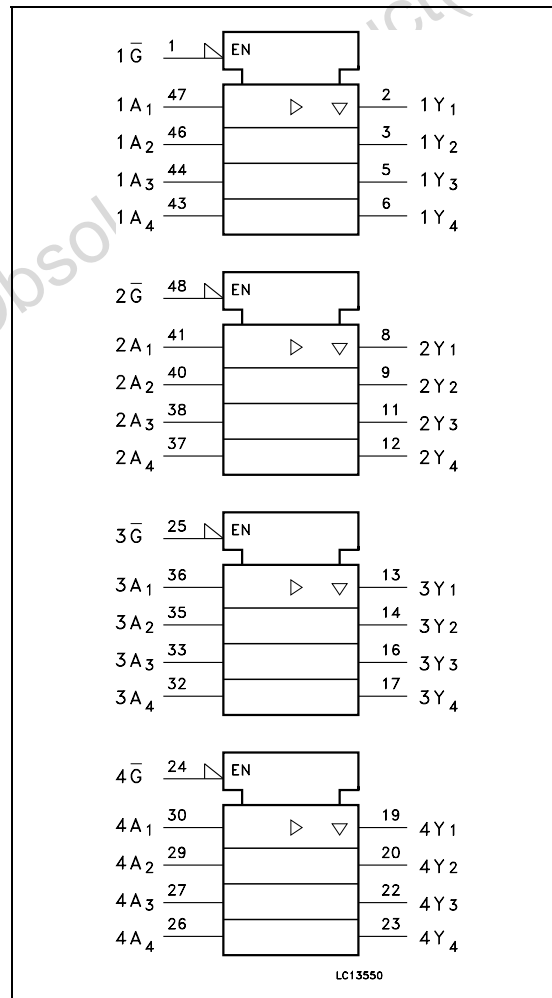

TRUTH TABLE

| INPUTS | | OUTPUT |
|-----------|----------------|----------------|
| \bar{G} | A _n | Y _n |
| L | L | L |
| L | H | H |
| H | X | Z |

X : Don't Care
Z : High Impedance

ABSOLUTE MAXIMUM RATINGS

| Symbol | Parameter | Value | Unit |
|-----------------------|--|------------------------|------|
| V_{CC} | Supply Voltage | -0.5 to +4.6 | V |
| V_I | DC Input Voltage | -0.5 to +4.6 | V |
| V_O | DC Output Voltage (OFF State) | -0.5 to +4.6 | V |
| V_O | DC Output Voltage (High or Low State) (note 1) | -0.5 to $V_{CC} + 0.5$ | V |
| I_{IK} | DC Input Diode Current | - 50 | mA |
| I_{OK} | DC Output Diode Current (note 2) | - 50 | mA |
| I_O | DC Output Current | ± 50 | mA |
| I_{CC} or I_{GND} | DC V_{CC} or Ground Current per Supply Pin | ± 100 | mA |
| P_D | Power Dissipation | 400 | mW |
| T_{stg} | Storage Temperature | -65 to +150 | °C |
| T_L | Lead Temperature (10 sec) | 300 | °C |

Absolute Maximum Ratings are those values beyond which damage to the device may occur. Functional operation under these conditions is not implied

1) I_O absolute maximum rating must be observed

2) $V_O < GND$, $V_O > V_{CC}$

RECOMMENDED OPERATING CONDITIONS

| Symbol | Parameter | Value | Unit |
|---------------------|---|---------------|------|
| V_{CC} | Supply Voltage | 1.65 to 3.6 | V |
| V_I | Input Voltage | -0.3 to 3.6 | V |
| V_O | Output Voltage (OFF State) | 0 to 3.6 | V |
| V_O | Output Voltage (High or Low State) | 0 to V_{CC} | V |
| I_{OH} , I_{OL} | High or Low Level Output Current ($V_{CC} = 3.0$ to $3.6V$) | ± 24 | mA |
| I_{OH} , I_{OL} | High or Low Level Output Current ($V_{CC} = 2.3$ to $2.7V$) | ± 12 | mA |
| I_{OH} , I_{OL} | High or Low Level Output Current ($V_{CC} = 1.65V$) | ± 4 | mA |
| T_{op} | Operating Temperature | -55 to 125 | °C |
| dt/dv | Input Rise and Fall Time (note 1) | 0 to 10 | ns/V |

1) V_{IN} from 0.8V to 2V at $V_{CC} = 3.0V$

DC SPECIFICATIONS

| Symbol | Parameter | Test Condition | | Value | | | | Unit |
|--------------------|---------------------------------------|------------------------|--|----------------------|----------------------|----------------------|----------------------|------|
| | | V _{CC} (V) | | -40 to 85 °C | | -55 to 125 °C | | |
| | | | | Min. | Max. | Min. | Max. | |
| V _{IH} | High Level Input Voltage | 1.65 to 1.95 | | 0.65 V _{CC} | | 0.65 V _{CC} | | V |
| | | 2.3 to 2.7 | | 1.7 | | 1.7 | | |
| | | 2.7 to 3.6 | | 2.0 | | 2.0 | | |
| V _{IL} | Low Level Input Voltage | 1.65 to 1.95 | | | 0.35 V _{CC} | | 0.35 V _{CC} | V |
| | | 2.3 to 2.7 | | | 0.7 | | 0.7 | |
| | | 2.7 to 3.6 | | | 0.8 | | 0.8 | |
| V _{OH} | High Level Output Voltage | 1.65 to 3.6 | I _O =-100 μA | V _{CC} -0.2 | | V _{CC} -0.2 | | V |
| | | 1.65 | I _O =-4 mA | 1.2 | | 1.2 | | |
| | | 2.3 | I _O =-6 mA | 2.0 | | 2.0 | | |
| | | 2.3 | I _O =-12 mA | 1.7 | | 1.7 | | |
| | | 2.7 | I _O =-12 mA | 2.2 | | 2.2 | | |
| | | 3.0 | I _O =-12 mA | 2.4 | | 2.4 | | |
| | | 3.0 | I _O =-24 mA | 2.0 | | 2.0 | | |
| V _{OL} | Low Level Output Voltage | 1.65 to 3.6 | I _O =100 μA | | 0.2 | | 0.2 | V |
| | | 1.65 | I _O =4 mA | | 0.45 | | 0.45 | |
| | | 2.3 | I _O =6 mA | | 0.4 | | 0.4 | |
| | | 2.3 | I _O =12 mA | | 0.7 | | 0.7 | |
| | | 2.7 | I _O =12 mA | | 0.4 | | 0.4 | |
| | | 3.0 | I _O =24 mA | | 0.55 | | 0.55 | |
| I _I | Input Leakage Current | 3.6 | V _I = 0 or 3.6V | | ± 5 | | ± 5 | μA |
| I _{IHOLD} | Input Hold Current | 1.65 | V _I = 0.58 V | + 25 | | + 25 | | μA |
| | | 1.65 | V _I = 1.07 V | - 25 | | - 25 | | |
| | | 2.3 | V _I = 0.7 V | + 45 | | + 45 | | |
| | | 2.3 | V _I = 1.7 V | - 45 | | - 45 | | |
| | | 3.0 | V _I = 0.8 V | + 75 | | + 75 | | |
| | | 3.0 | V _I = 2 V | - 75 | | - 75 | | |
| | | 3.6 | V _I = 0 to 3.6V | | ± 500 | | ± 500 | |
| I _{off} | Power Off Leakage Current | 0 | V _I or V _O = 3.6V | | 10 | | 20 | μA |
| I _{OZ} | High Impedance Output Leakage Current | 3.6 | V _I = V _{IH} or V _{IL} V _O = 0 to V _{CC} | | ± 5 | | ± 10 | μA |
| I _{CC} | Quiescent Supply Current | 3.6 | V _I = V _{CC} or GND I _O = 0 | | 20 | | 40 | μA |
| ΔI _{CC} | I _{CC} incr. per Input | 3.0 to 3.6 | V _{IH} = V _{CC} - 0.6V | | 500 | | 750 | μA |

AC ELECTRICAL CHARACTERISTICS

| Symbol | Parameter | Test Condition | | | | Value | | | | Unit |
|-----------------------------------|------------------------|------------------------|------------------------|-----------------------|---|--------------|------|---------------|------|------|
| | | V _{CC} (V) | C _L (pF) | R _L (Ω) | t _s = t _r (ns) | -40 to 85 °C | | -55 to 125 °C | | |
| | | | | | | Min. | Max. | Min. | Max. | |
| t _{PLH} t _{PHL} | Propagation Delay Time | 1.65 to 1.95 | 30 | 1000 | 2.0 | 1 | 5.1 | 1 | 5.1 | ns |
| | | 2.3 to 2.7 | 30 | 500 | 2.0 | 1 | 3.7 | 1 | 3.7 | |
| | | 2.7 | 50 | 500 | 2.5 | 1 | 3.6 | 1 | 3.6 | |
| | | 3.0 to 3.6 | 50 | 500 | 2.5 | 1 | 3.0 | 1 | 3.0 | |
| t _{PZL} t _{PZH} | Output Enable Time | 1.65 to 1.95 | 30 | 1000 | 2.0 | 1 | 7.1 | 1 | 7.1 | |
| | | 2.3 to 2.7 | 30 | 500 | 2.0 | 1 | 5.7 | 1 | 5.7 | |
| | | 2.7 | 50 | 500 | 2.5 | 1 | 5.4 | 1 | 5.4 | |
| | | 3.0 to 3.6 | 50 | 500 | 2.5 | 1 | 4.4 | 1 | 4.4 | |
| t _{PLZ} t _{PHZ} | Output Disable Time | 1.65 to 1.95 | 30 | 1000 | 2.0 | 1 | 6.5 | 1 | 6.5 | |
| | | 2.3 to 2.7 | 30 | 500 | 2.0 | 1 | 5.2 | 1 | 5.2 | |
| | | 2.7 | 50 | 500 | 2.5 | 1 | 4.6 | 1 | 4.6 | |
| | | 3.0 to 3.6 | 50 | 500 | 2.5 | 1 | 4.1 | 1 | 4.1 | |

1) Skew is defined as the absolute value of the difference between the actual propagation delay for any two outputs of the same device switching in the same direction, either HIGH or LOW ($t_{OSLH} = |t_{PLHm} - t_{PLHn}|$, $t_{OSHL} = |t_{PHLm} - t_{PHLn}|$)
 2) Parameter guaranteed by design

CAPACITIVE CHARACTERISTICS

| Symbol | Parameter | Test Condition | | Value | | | Unit |
|------------------|--|------------------------|--|------------------------|------|------|------|
| | | V _{CC} (V) | | T _A = 25 °C | | | |
| | | | | Min. | Typ. | Max. | |
| C _{IN} | Input Capacitance Control Inputs | 3.3 | V _{IN} = V _{CC} or GND | | 3 | | pF |
| C _{IN} | Input Capacitance Data Inputs | 3.3 | V _{IN} = V _{CC} or GND | | 6 | | pF |
| C _{OUT} | Output Capacitance | 3.3 | V _{IN} = 0 to V _{CC} | | 7 | | pF |
| C _{PD} | Power Dissipation Capacitance Output enabled (note 1) | 3.3 | f _{IN} = 10MHz C _L = 50pF V _{IN} = 0 or V _{CC} | | 19 | | pF |
| | | 2.5 | | | 16 | | |
| C _{PD} | Power Dissipation Capacitance Output disabled (note 1) | 3.3 | | | 5 | | |
| | | 2.5 | | | 4 | | |

1) C_{PD} is defined as the value of the IC's internal equivalent capacitance which is calculated from the operating current consumption without load. (Refer to Test Circuit). Average operating current can be obtained by the following equation. $I_{CC(opr)} = C_{PD} \times V_{CC} \times f_{IN} + I_{CC}/16$ (per circuit)

74ALVCH16244

TEST CIRCUIT

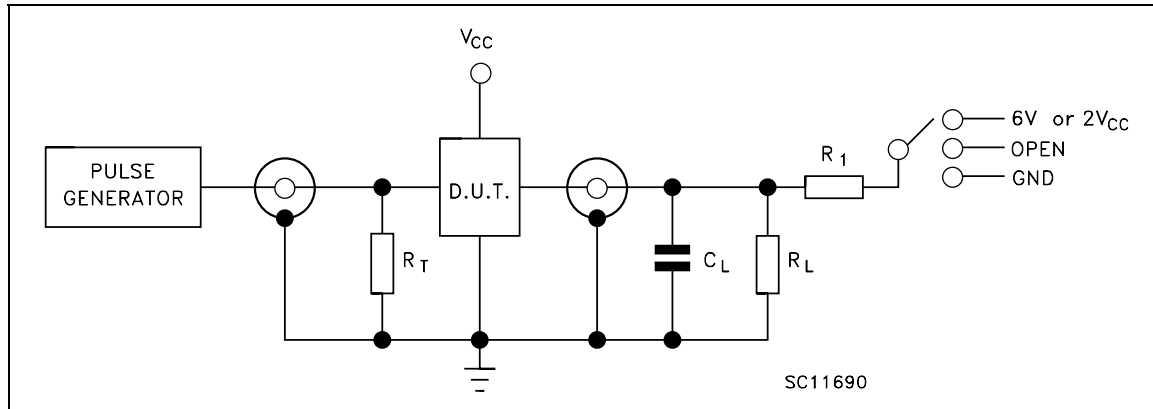

| TEST | SWITCH |
|--|-----------|
| t_{PLH} , t_{PHL} | Open |
| t_{PZL} , t_{PLZ} ($V_{CC} = 3.0$ to $3.6V$) | 6V |
| t_{PZL} , t_{PLZ} ($V_{CC} = 2.3$ to $2.7V$) | $2V_{CC}$ |
| t_{PZH} , t_{PHZ} | GND |

$R_T = Z_{OUT}$ of pulse generator (typically 50Ω)

TEST CIRCUIT AND WAVEFORM SYMBOL VALUE

| Symbol | V_{CC} | | | |
|-------------|-----------------|-----------------|------------------|------------------|
| | 3.0 to 3.6V | 2.7V | 2.3 to 2.7V | 1.65 to 1.95V |
| V_{IH} | 2.7V | 2.7V | V_{CC} | V_{CC} |
| V_M | 1.5V | 1.5V | $V_{CC}/2$ | $V_{CC}/2$ |
| V_X | $V_{OL} + 0.3V$ | $V_{OL} + 0.3V$ | $V_{OL} + 0.15V$ | $V_{OL} + 0.15V$ |
| V_Y | $V_{OH} - 0.3V$ | $V_{OH} - 0.3V$ | $V_{OH} - 0.15V$ | $V_{OH} - 0.15V$ |
| C_L | 50pF | 50pF | 30pF | 30pF |
| $R_L = R_1$ | 500 Ω | 500 Ω | 500 Ω | 1000 Ω |
| $t_r = t_f$ | <2.5ns | <2.5ns | <2.0ns | <2.0ns |

TSSOP48 MECHANICAL DATA

| DIM. | mm. | | | inch | | |
|------|------|---------|------|--------|------------|--------|
| | MIN. | TYP | MAX. | MIN. | TYP. | MAX. |
| A | | | 1.2 | | | 0.047 |
| A1 | 0.05 | | 0.15 | 0.002 | | 0.006 |
| A2 | | 0.9 | | | 0.035 | |
| b | 0.17 | | 0.27 | 0.0067 | | 0.011 |
| c | 0.09 | | 0.20 | 0.0035 | | 0.0079 |
| D | 12.4 | | 12.6 | 0.488 | | 0.496 |
| E | | 8.1 BSC | | | 0.318 BSC | |
| E1 | 6.0 | | 6.2 | 0.236 | | 0.244 |
| e | | 0.5 BSC | | | 0.0197 BSC | |
| K | 0° | | 8° | 0° | | 8° |
| L | 0.50 | | 0.75 | 0.020 | | 0.030 |

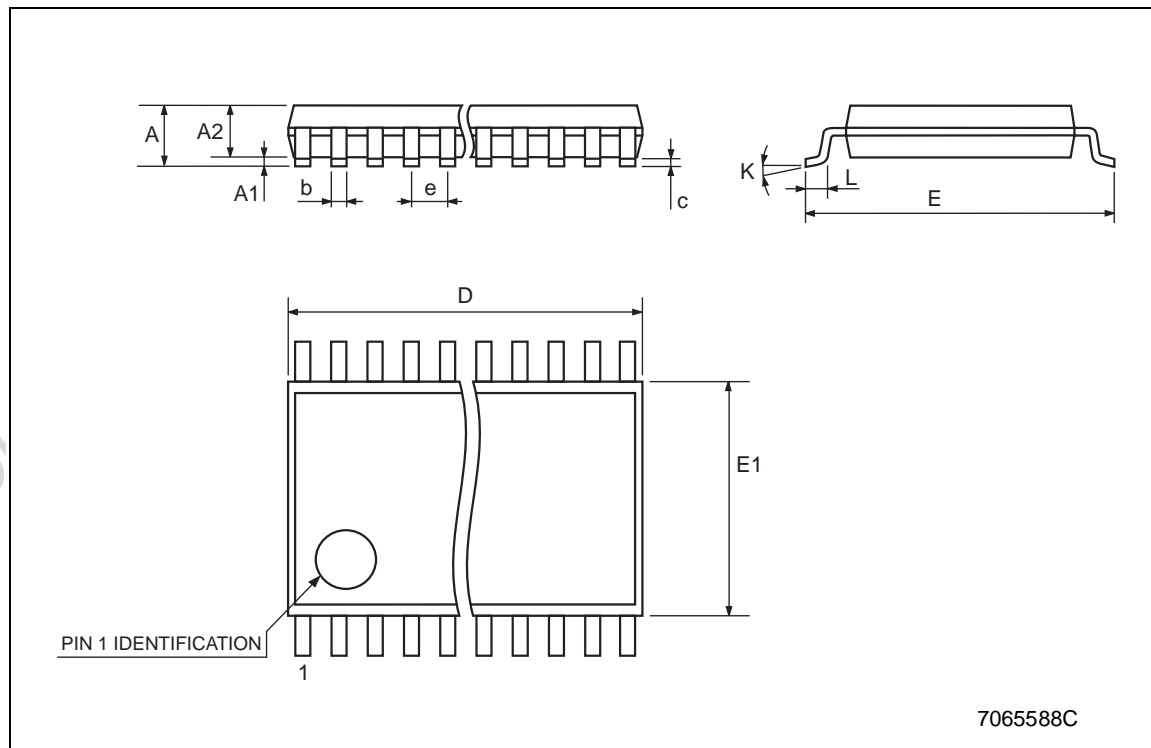

Tape & Reel TSSOP48 MECHANICAL DATA

| DIM. | mm. | | | inch | | |
|------|------|------|------|-------|------|--------|
| | MIN. | TYP. | MAX. | MIN. | TYP. | MAX. |
| A | | | 330 | | | 12.992 |
| C | 12.8 | | 13.2 | 0.504 | | 0.519 |
| D | 20.2 | | | 0.795 | | |
| N | 60 | | | 2.362 | | |
| T | | | 30.4 | | | 1.197 |
| Ao | 8.7 | | 8.9 | 0.343 | | 0.350 |
| Bo | 13.1 | | 13.3 | 0.516 | | 0.524 |
| Ko | 1.5 | | 1.7 | 0.059 | | 0.067 |
| Po | 3.9 | | 4.1 | 0.153 | | 0.161 |
| P | 11.9 | | 12.1 | 0.468 | | 0.476 |

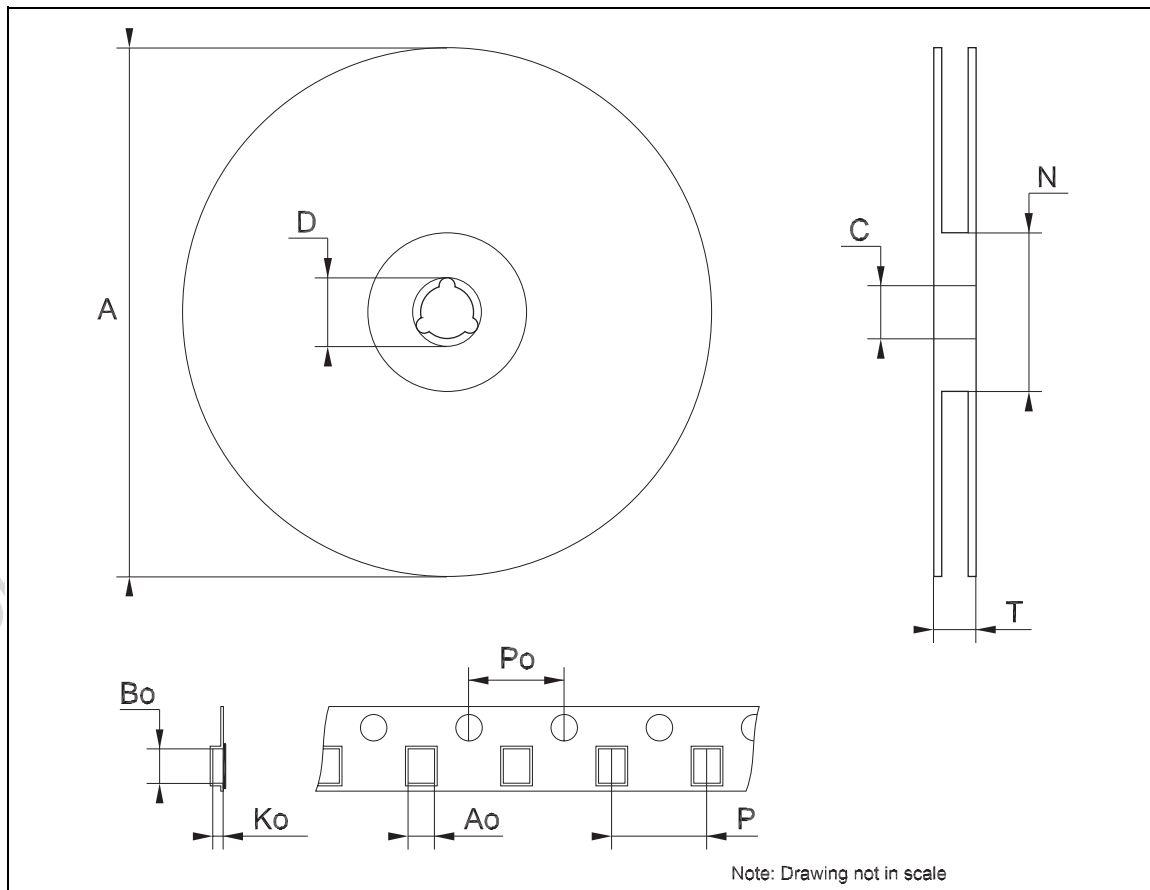

Information furnished is believed to be accurate and reliable. However, STMicroelectronics assumes no responsibility for the consequences of use of such information nor for any infringement of patents or other rights of third parties which may result from its use. No license is granted by implication or otherwise under any patent or patent rights of STMicroelectronics. Specifications mentioned in this publication are subject to change without notice. This publication supersedes and replaces all information previously supplied. STMicroelectronics products are not authorized for use as critical components in life support devices or systems without express written approval of STMicroelectronics.

© The ST logo is a registered trademark of STMicroelectronics

© 2003 STMicroelectronics - Printed in Italy - All Rights Reserved
STMicroelectronics GROUP OF COMPANIES

Australia - Brazil - Canada - China - Finland - France - Germany - Hong Kong - India - Israel - Italy - Japan - Malaysia - Malta - Morocco
Singapore - Spain - Sweden - Switzerland - United Kingdom - United States.

© <http://www.st.com>