

## OCTAL BUS BUFFER WITH 3 STATE OUTPUTS (NON INVERTED)

- HIGH SPEED:  $t_{PD} = 3.9 \text{ ns}$  (TYP.) at  $V_{CC} = 5V$
- LOW POWER DISSIPATION:  
 $I_{CC} = 4 \mu\text{A}$  (MAX.) at  $T_A = 25^\circ\text{C}$
- HIGH NOISE IMMUNITY:  
 $V_{NIH} = V_{NIL} = 28\% V_{CC}$  (MIN.)
- POWER DOWN PROTECTION ON INPUTS
- SYMMETRICAL OUTPUT IMPEDANCE:  
 $|I_{OH}| = I_{OL} = 8 \text{ mA}$  (MIN)
- BALANCED PROPAGATION DELAYS:  
 $t_{PLH} \cong t_{PHL}$
- OPERATING VOLTAGE RANGE:  
 $V_{CC}(\text{OPR}) = 2V \text{ to } 5.5V$
- PIN AND FUNCTION COMPATIBLE WITH 74 SERIES 244
- IMPROVED LATCH-UP IMMUNITY
- LOW NOISE:  $V_{OLP} = 0.9V$  (MAX.)

### DESCRIPTION

The 74VHC244 is an advanced high-speed CMOS OCTAL BUS BUFFER (3-STATE) fabricated with sub-micron silicon gate and double-layer metal wiring C<sup>2</sup>MOS technology.  $\overline{G}$  output enable governs four BUS BUFFERS. This device is designed to be used with 3 state memory address drivers, etc.

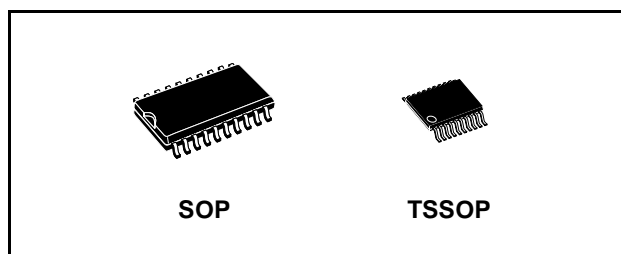

Table 1: Order Codes

PACKAGE	T & R
SOP	74VHC244MTR
TSSOP	74VHC244TTR

Power down protection is provided on all inputs and 0 to 7V can be accepted on inputs with no regard to the supply voltage. This device can be used to interface 5V to 3V.

All inputs and outputs are equipped with protection circuits against static discharge, giving them 2KV ESD immunity and transient excess voltage.

Figure 1: Pin Connection And IEC Logic Symbols

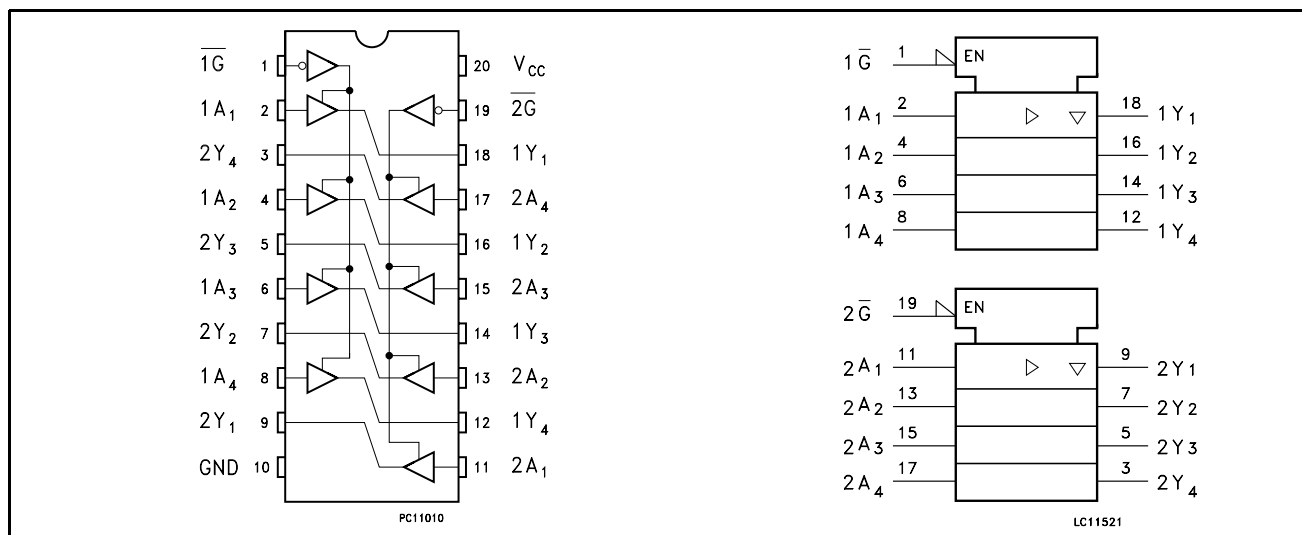

Figure 2: Input Equivalent Circuit

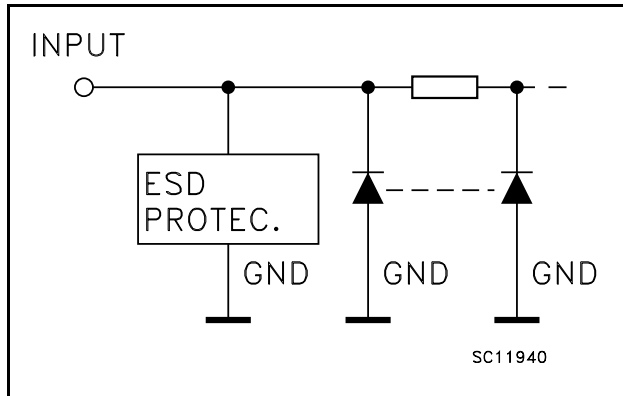

Table 2: Pin Description

PIN N°	SYMBOL	NAME AND FUNCTION
1	1G	Output Enable Input
2, 4, 6, 8	1A1 to 1A4	Data Inputs
9, 7, 5, 3	2Y1 to 2Y4	Data Outputs
11, 13, 15, 17	2A1 to 2A4	Data Inputs
18, 16, 14, 12	1Y1 to 1Y4	Data Outputs
19	2G	Output Enable Input
10	GND	Ground (0V)
20	V <sub>CC</sub>	Positive Supply Voltage

Table 3: Truth Table

INPUTS		OUTPUT
$\overline{\text{G}}$	An	Yn
L	L	L
L	H	H
H	X	Z

X : Don't Care  
Z : High Impedance

Table 4: Absolute Maximum Ratings

Symbol	Parameter	Value	Unit
V <sub>CC</sub>	Supply Voltage	-0.5 to +7.0	V
V <sub>I</sub>	DC Input Voltage	-0.5 to +7.0	V
V <sub>O</sub>	DC Output Voltage	-0.5 to V <sub>CC</sub> + 0.5	V
I <sub>IK</sub>	DC Input Diode Current	- 20	mA
I <sub>OK</sub>	DC Output Diode Current	± 20	mA
I <sub>O</sub>	DC Output Current	± 25	mA
I <sub>CC</sub> or I <sub>GND</sub>	DC V <sub>CC</sub> or Ground Current	± 75	mA
T <sub>stg</sub>	Storage Temperature	-65 to +150	°C
T <sub>L</sub>	Lead Temperature (10 sec)	300	°C

Absolute Maximum Ratings are those values beyond which damage to the device may occur. Functional operation under these conditions is not implied

Table 5: Recommended Operating Conditions

Symbol	Parameter	Value	Unit
V <sub>CC</sub>	Supply Voltage	2 to 5.5	V
V <sub>I</sub>	Input Voltage	0 to 5.5	V
V <sub>O</sub>	Output Voltage	0 to V <sub>CC</sub>	V
T <sub>op</sub>	Operating Temperature	-55 to 125	°C
dt/dv	Input Rise and Fall Time (note 1) (V <sub>CC</sub> = 3.3 ± 0.3V) (V <sub>CC</sub> = 5.0 ± 0.5V)	0 to 100 0 to 20	ns/V

1) V<sub>IN</sub> from 30% to 70% of V<sub>CC</sub>

Table 6: DC Specifications

Symbol	Parameter	Test Condition		Value						Unit	
		V <sub>CC</sub> (V)		T <sub>A</sub> = 25°C			-40 to 85°C		-55 to 125°C		
				Min.	Typ.	Max.	Min.	Max.	Min.		Max.
V <sub>IH</sub>	High Level Input Voltage	2.0		1.5			1.5		1.5		V
		3.0 to 5.5		0.7V <sub>CC</sub>			0.7V <sub>CC</sub>		0.7V <sub>CC</sub>		
V <sub>IL</sub>	Low Level Input Voltage	2.0				0.5		0.5		0.5	V
		3.0 to 5.5				0.3V <sub>CC</sub>		0.3V <sub>CC</sub>		0.3V <sub>CC</sub>	
V <sub>OH</sub>	High Level Output Voltage	2.0	I <sub>O</sub> =-50 μA	1.9	2.0		1.9		1.9		V
		3.0	I <sub>O</sub> =-50 μA	2.9	3.0		2.9		2.9		
		4.5	I <sub>O</sub> =-50 μA	4.4	4.5		4.4		4.4		
		3.0	I <sub>O</sub> =-4 mA	2.58			2.48		2.4		
		4.5	I <sub>O</sub> =-8 mA	3.94			3.8		3.7		
V <sub>OL</sub>	Low Level Output Voltage	2.0	I <sub>O</sub> =50 μA		0.0	0.1		0.1		0.1	V
		3.0	I <sub>O</sub> =50 μA		0.0	0.1		0.1		0.1	
		4.5	I <sub>O</sub> =50 μA		0.0	0.1		0.1		0.1	
		3.0	I <sub>O</sub> =4 mA			0.36		0.44		0.55	
		4.5	I <sub>O</sub> =8 mA			0.36		0.44		0.55	
I <sub>OZ</sub>	High Impedance Output Leakage Current	5.5	V <sub>I</sub> = V <sub>IH</sub> or V <sub>IL</sub> V <sub>O</sub> = V <sub>CC</sub> or GND			±0.25		± 2.5		± 2.5	μA
I <sub>I</sub>	Input Leakage Current	0 to 5.5	V <sub>I</sub> = 5.5V or GND			± 0.1		± 1		± 1	μA
I <sub>CC</sub>	Quiescent Supply Current	5.5	V <sub>I</sub> = V <sub>CC</sub> or GND			4		40		40	μA

Table 7: AC Electrical Characteristics (Input  $t_r = t_f = 3\text{ns}$ )

Symbol	Parameter	Test Condition			Value						Unit	
		$V_{CC}$ (V)	$C_L$ (pF)		$T_A = 25^\circ\text{C}$			$-40$ to $85^\circ\text{C}$		$-55$ to $125^\circ\text{C}$		
					Min.	Typ.	Max.	Min.	Max.	Min.		Max.
$t_{PLH}$ $t_{PHL}$	Propagation Delay Time	3.3(*)	15			5.8	8.4	1.0	10.0	1.0	10.0	ns
		3.3(*)	50			8.3	11.9	1.0	13.5	1.0	13.5	
		5.0(**)	15			3.9	5.5	1.0	6.5	1.0	6.5	
		5.0(**)	50			5.4	7.5	1.0	8.5	1.0	8.5	
$t_{PZL}$ $t_{PZH}$	Output Enable Time	3.3(*)	15	$R_L = 1\text{K}\Omega$		6.6	10.6	1.0	12.5	1.0	12.5	ns
		3.3(*)	50	$R_L = 1\text{K}\Omega$		9.1	14.1	1.0	16.0	1.0	16.0	
		5.0(**)	15	$R_L = 1\text{K}\Omega$		4.7	7.3	1.0	8.5	1.0	8.5	
		5.0(**)	50	$R_L = 1\text{K}\Omega$		6.2	9.3	1.0	10.5	1.0	10.5	
$t_{PLZ}$ $t_{PHZ}$	Output Disable Time	3.3(*)	50	$R_L = 1\text{K}\Omega$		10.3	14.0	1.0	16.0	1.0	16.0	ns
		5.0(**)	50	$R_L = 1\text{K}\Omega$		6.7	9.2	1.0	10.5	1.0	10.5	
$t_{OSLH}$ $t_{OSHL}$	Output to Output Skew time (note 1)	3.3(*)	50				1.5		1.5		1.5	ns
		5.0(**)	50				1.0		1.0		1.0	

(\*) Voltage range is  $3.3\text{V} \pm 0.3\text{V}$ (\*\*) Voltage range is  $5.0\text{V} \pm 0.5\text{V}$ Note 1: Parameter guaranteed by design.  $t_{solH} = |t_{pLHm} - t_{pLHn}|$ ,  $t_{soHL} = |t_{pHLm} - t_{pHLn}|$ 

Table 8: Capacitive Characteristics

Symbol	Parameter	Test Condition			Value						Unit	
					$T_A = 25^\circ\text{C}$			$-40$ to $85^\circ\text{C}$		$-55$ to $125^\circ\text{C}$		
					Min.	Typ.	Max.	Min.	Max.	Min.		Max.
$C_{IN}$	Input Capacitance					4	10		10		10	pF
$C_{OUT}$	Output Capacitance					6						pF
$C_{PD}$	Power Dissipation Capacitance (note 1)					19						pF

1)  $C_{PD}$  is defined as the value of the IC's internal equivalent capacitance which is calculated from the operating current consumption without load. (Refer to Test Circuit). Average operating current can be obtained by the following equation.  $I_{CC(opr)} = C_{PD} \times V_{CC} \times f_{IN} + I_{CC}/8$  (per circuit)

Table 9: Dynamic Switching Characteristics

Symbol	Parameter	Test Condition		Value						Unit	
		V <sub>CC</sub> (V)	C <sub>L</sub> = 50 pF	T <sub>A</sub> = 25°C			-40 to 85°C		-55 to 125°C		
				Min.	Typ.	Max.	Min.	Max.	Min.		Max.
V <sub>OLP</sub>	Dynamic Low Voltage Quiet Output (note 1, 2)	5.0	C <sub>L</sub> = 50 pF		0.6	0.9					V
V <sub>OLV</sub>				-0.9	-0.6						
V <sub>IHD</sub>	Dynamic High Voltage Input (note 1, 3)	5.0		3.5						V	
V <sub>ILD</sub>	Dynamic Low Voltage Input (note 1, 3)	5.0				1.5				V	

1) Worst case package.

2) Max number of outputs defined as (n). Data inputs are driven 0V to 5.0V, (n-1) outputs switching and one output at GND.

3) Max number of data inputs (n) switching. (n-1) switching 0V to 5.0V. Inputs under test switching: 5.0V to threshold (V<sub>ILD</sub>), 0V to threshold (V<sub>IHD</sub>), f=1MHz.

Table 10: Test Circuit

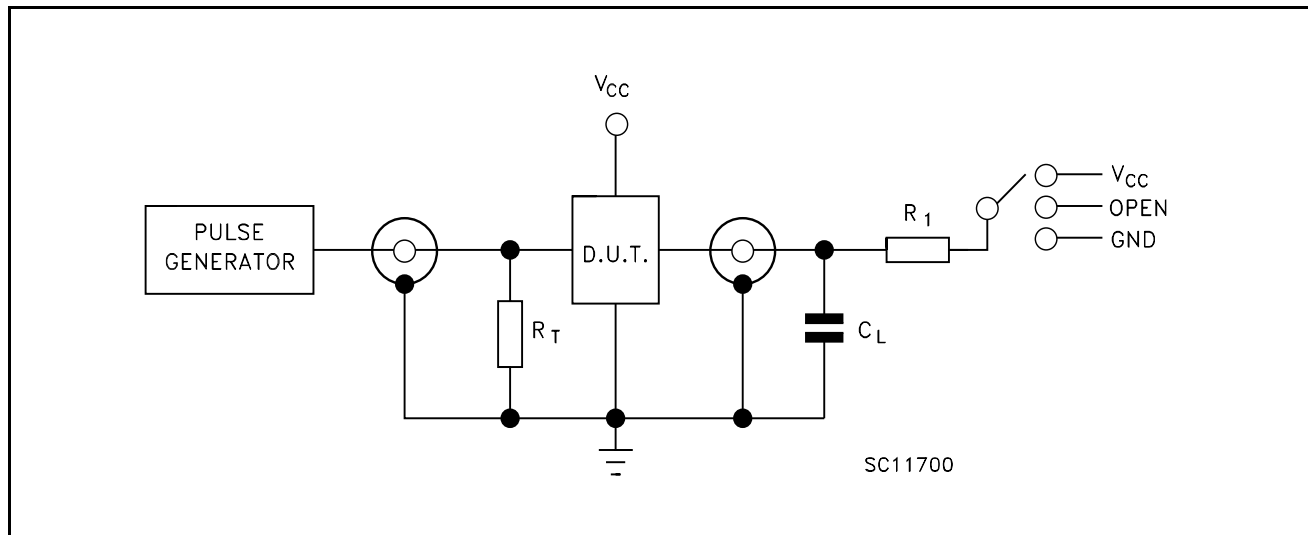

TEST	SWITCH
t <sub>PLH</sub> , t <sub>PHL</sub>	Open
t <sub>PZL</sub> , t <sub>PLZ</sub>	V <sub>CC</sub>
t <sub>PZH</sub> , t <sub>PHZ</sub>	GND

C<sub>L</sub> = 15/ 50pF or equivalent (includes jig and probe capacitance)

R<sub>L</sub> = R<sub>1</sub> = 1KΩ or equivalent

R<sub>T</sub> = Z<sub>OUT</sub> of pulse generator (typically 50Ω)

Figure 3: Waveform - Propagation Delays (f=1MHz; 50% duty cycle)

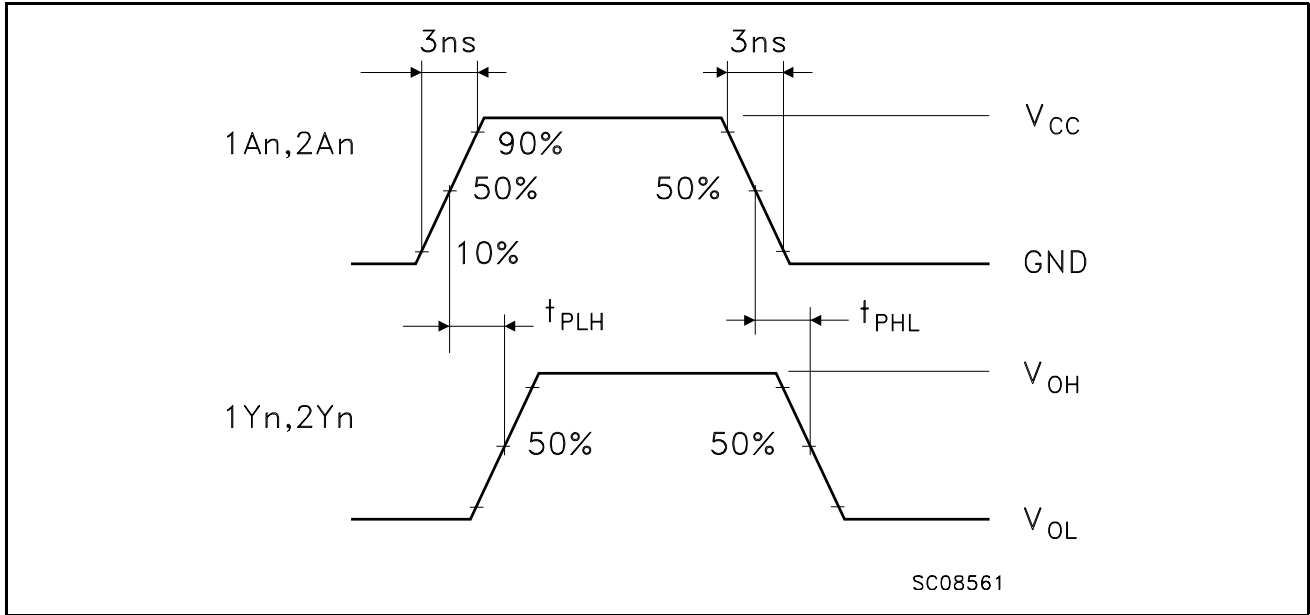
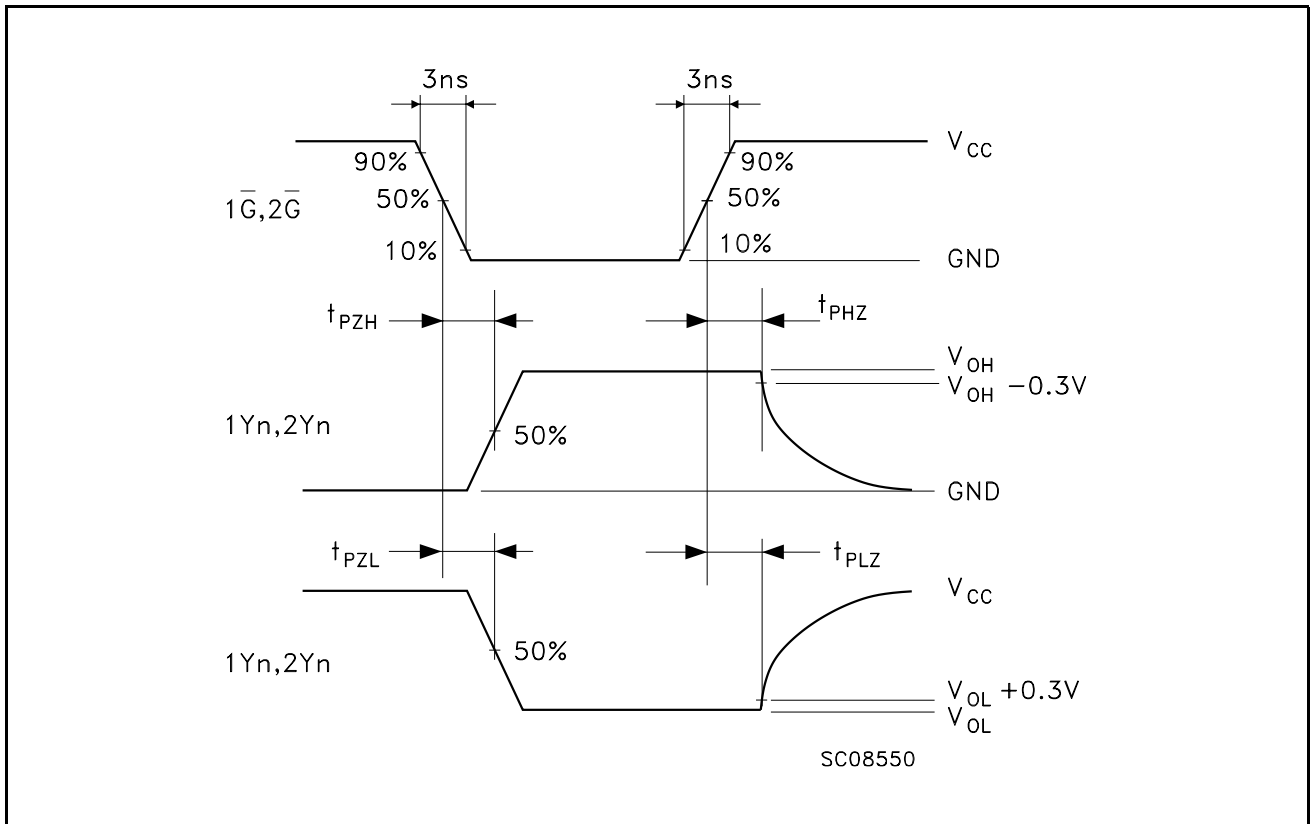
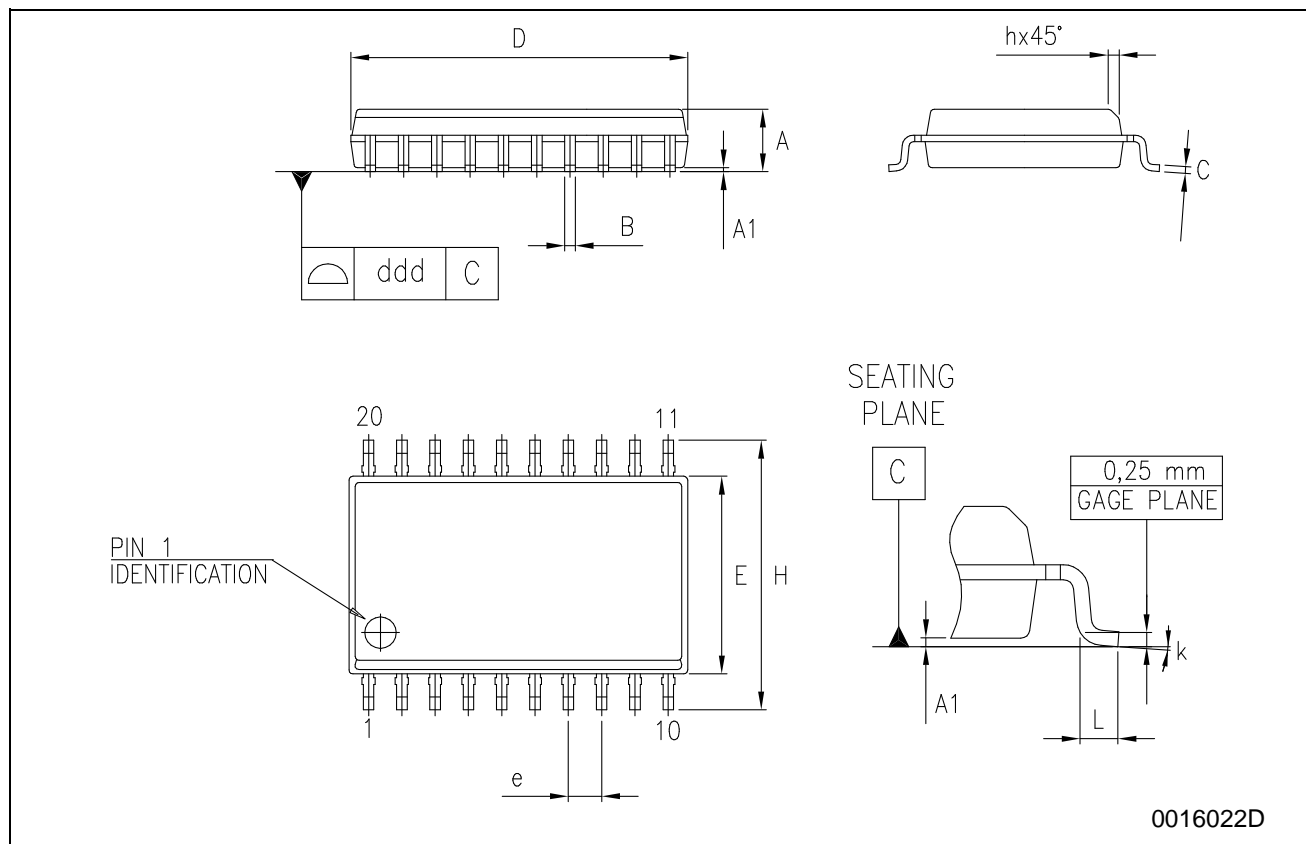

Figure 4: Waveform - Output Enable And Disable Time (f=1MHz; 50% duty cycle)



## SO-20 MECHANICAL DATA

DIM.	mm.			inch		
	MIN.	TYP	MAX.	MIN.	TYP.	MAX.
A	2.35		2.65	0.093		0.104
A1	0.1		0.30	0.004		0.012
B	0.33		0.51	0.013		0.020
C	0.23		0.32	0.009		0.013
D	12.60		13.00	0.496		0.512
E	7.4		7.6	0.291		0.299
e		1.27			0.050	
H	10.00		10.65	0.394		0.419
h	0.25		0.75	0.010		0.030
L	0.4		1.27	0.016		0.050
k	0°		8°	0°		8°
ddd			0.100			0.004



## TSSOP20 MECHANICAL DATA

DIM.	mm.			inch		
	MIN.	TYP	MAX.	MIN.	TYP.	MAX.
A			1.2			0.047
A1	0.05		0.15	0.002	0.004	0.006
A2	0.8	1	1.05	0.031	0.039	0.041
b	0.19		0.30	0.007		0.012
c	0.09		0.20	0.004		0.0079
D	6.4	6.5	6.6	0.252	0.256	0.260
E	6.2	6.4	6.6	0.244	0.252	0.260
E1	4.3	4.4	4.48	0.169	0.173	0.176
e		0.65 BSC			0.0256 BSC	
K	0°		8°	0°		8°
L	0.45	0.60	0.75	0.018	0.024	0.030

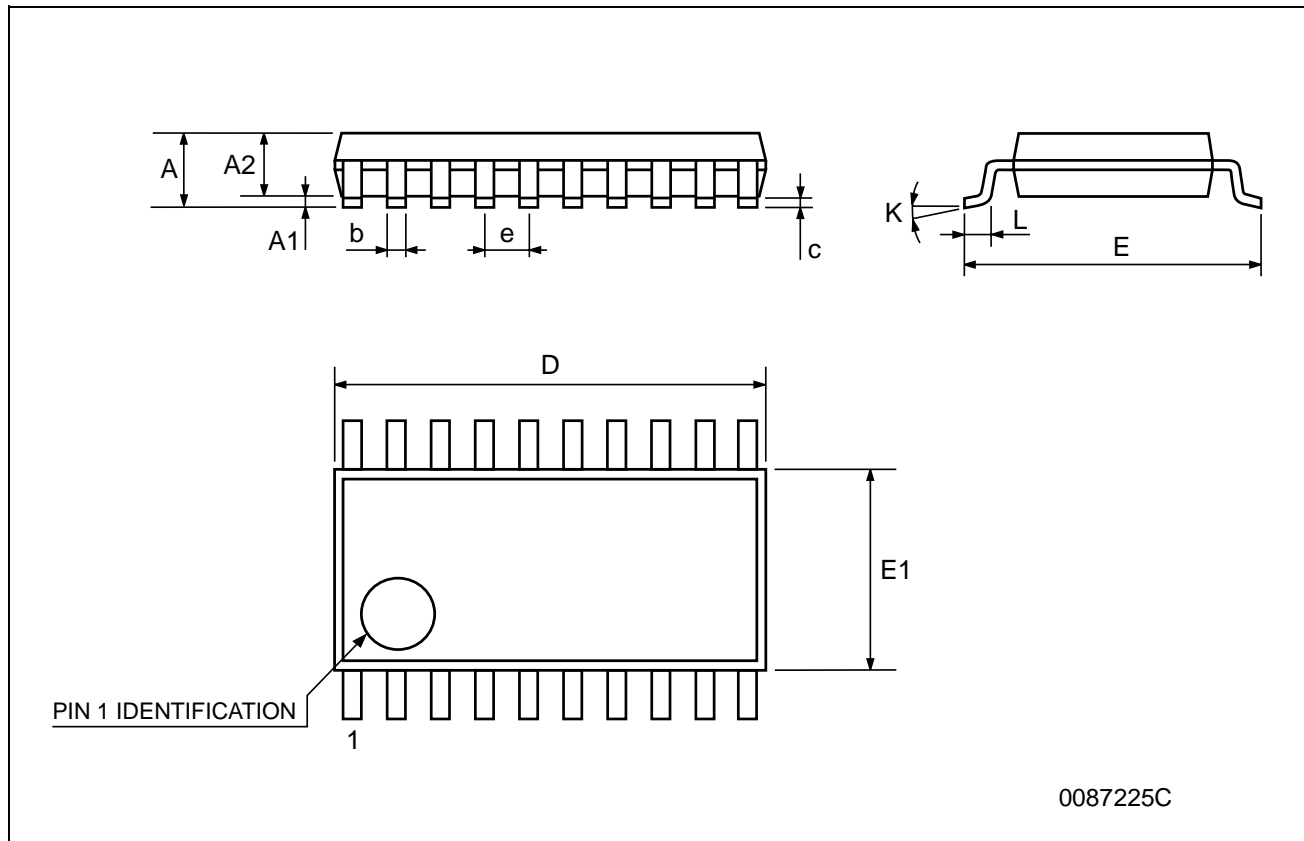



## Tape &amp; Reel SO-20 MECHANICAL DATA

DIM.	mm.			inch		
	MIN.	TYP.	MAX.	MIN.	TYP.	MAX.
A			330			12.992
C	12.8		13.2	0.504		0.519
D	20.2			0.795		
N	60			2.362		
T			30.4			1.197
Ao	10.8		11	0.425		0.433
Bo	13.2		13.4	0.520		0.528
Ko	3.1		3.3	0.122		0.130
Po	3.9		4.1	0.153		0.161
P	11.9		12.1	0.468		0.476

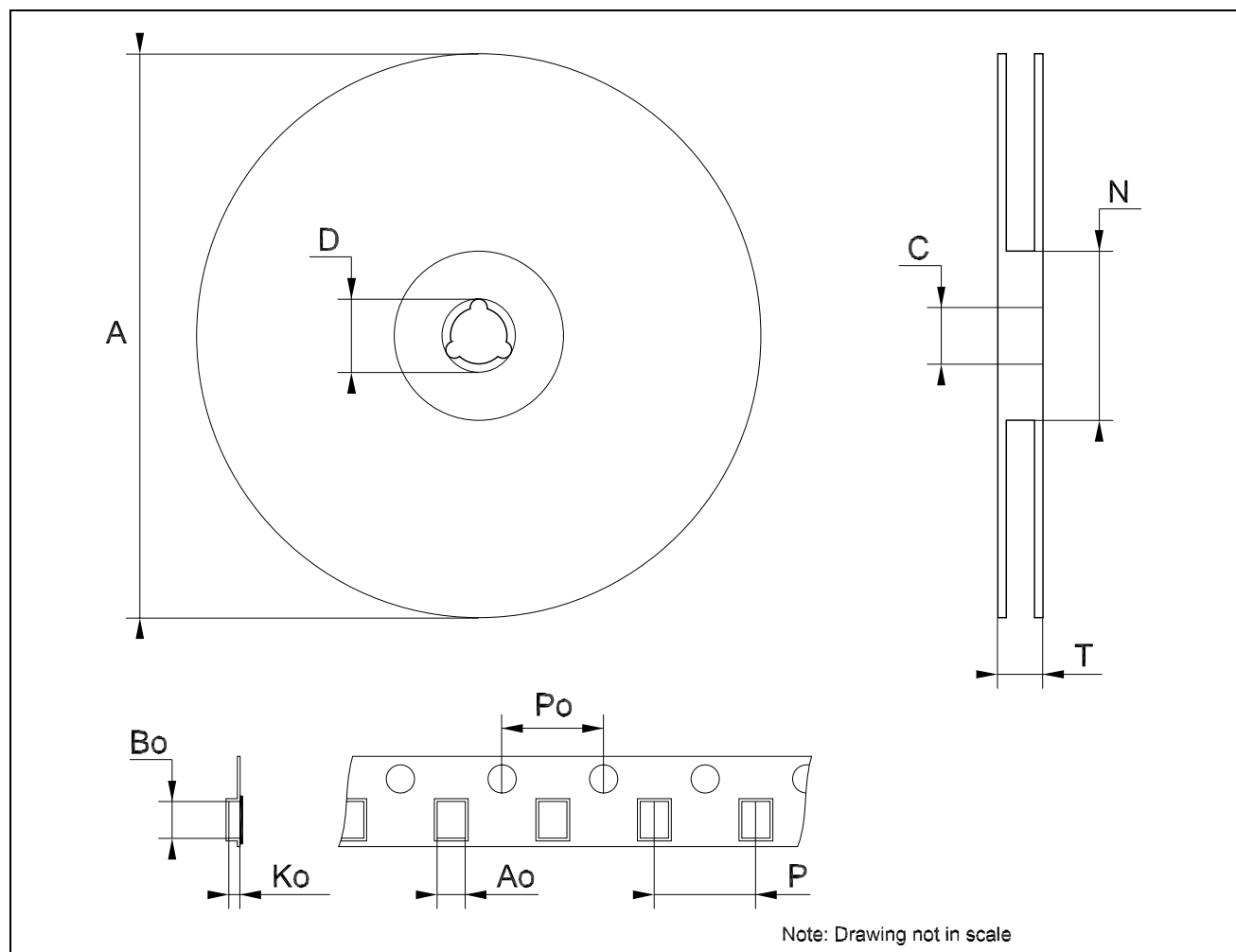

## Tape &amp; Reel TSSOP20 MECHANICAL DATA

DIM.	mm.			inch		
	MIN.	TYP.	MAX.	MIN.	TYP.	MAX.
A			330			12.992
C	12.8		13.2	0.504		0.519
D	20.2			0.795		
N	60			2.362		
T			22.4			0.882
Ao	6.8		7	0.268		0.276
Bo	6.9		7.1	0.272		0.280
Ko	1.7		1.9	0.067		0.075
Po	3.9		4.1	0.153		0.161
P	11.9		12.1	0.468		0.476

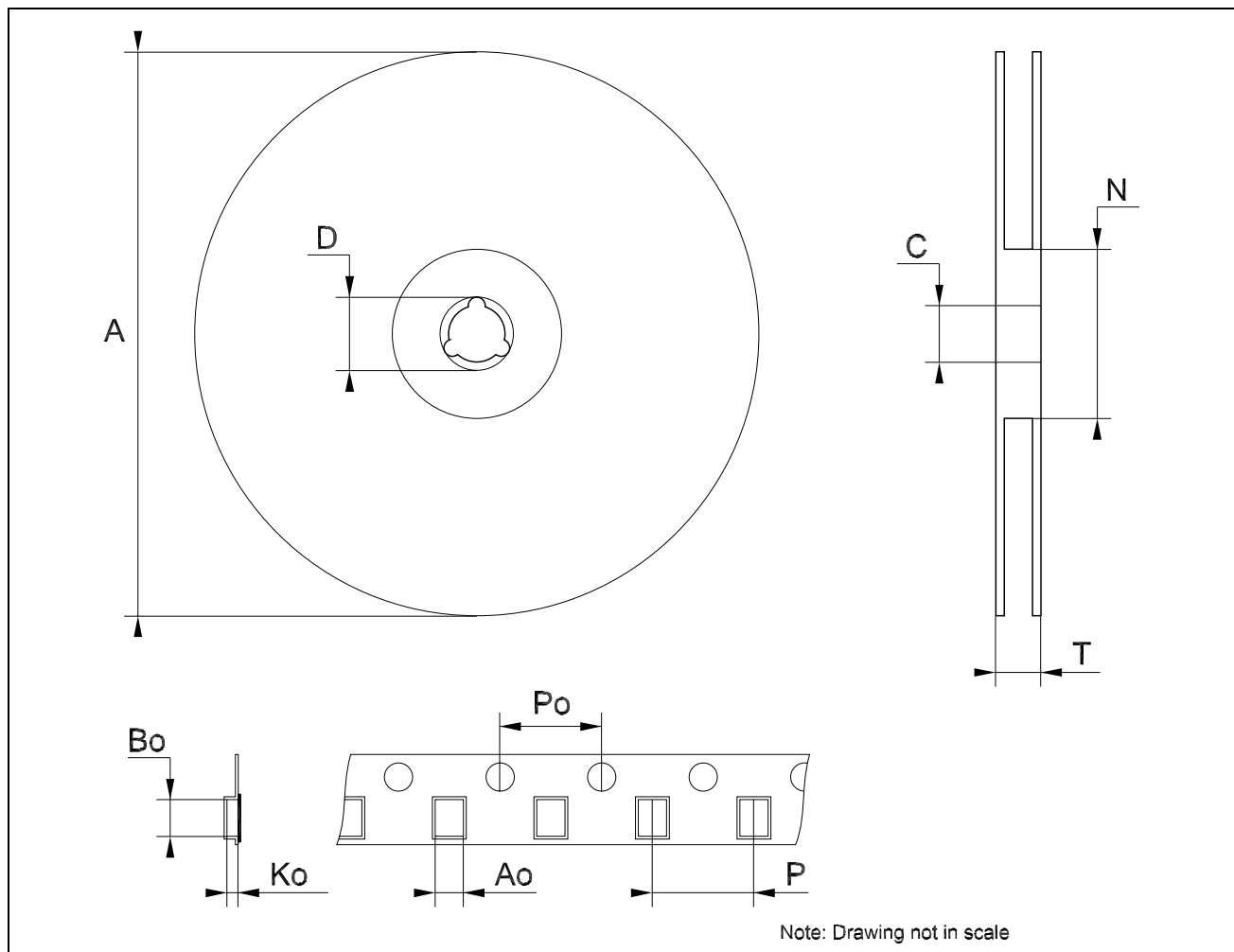

**Table 11: Revision History**

Date	Revision	Description of Changes
12-Nov-2004	3	Order Codes Revision - pag. 1.

Information furnished is believed to be accurate and reliable. However, STMicroelectronics assumes no responsibility for the consequences of use of such information nor for any infringement of patents or other rights of third parties which may result from its use. No license is granted by implication or otherwise under any patent or patent rights of STMicroelectronics. Specifications mentioned in this publication are subject to change without notice. This publication supersedes and replaces all information previously supplied. STMicroelectronics products are not authorized for use as critical components in life support devices or systems without express written approval of STMicroelectronics.

The ST logo is a registered trademark of STMicroelectronics

All other names are the property of their respective owners

© 2004 STMicroelectronics - All Rights Reserved

STMicroelectronics group of companies

Australia - Belgium - Brazil - Canada - China - Czech Republic - Finland - France - Germany - Hong Kong - India - Israel - Italy - Japan -  
Malaysia - Malta - Morocco - Singapore - Spain - Sweden - Switzerland - United Kingdom - United States of America

[www.st.com](http://www.st.com)