



LOW-NOISE VERTICAL DEFLECTION SYSTEM

FEATURES SUMMARY

- COMPLETE VERTICAL DEFLECTION SYSTEM
- LOW NOISE
- SUITABLE FOR HIGH DEFINITION MONITORS
- ESD PROTECTED

DESCRIPTION

The TDA1175P is a monolithic integrated circuit in POWERDIP16 plastic package. It is intended for use in black and white and colour TV receivers. Low-noise makes this device particularly suitable for use in monitors.

The functions incorporated are: synchronization circuit, oscillator and ramp generator, high power gain amplifier, flyback generator, voltage regulator.

Figure 1. Package

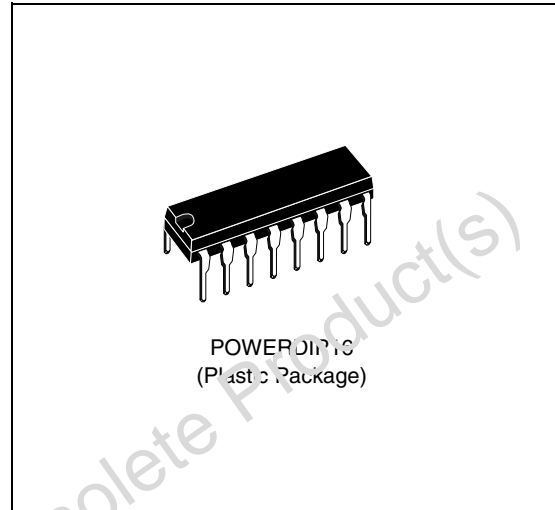
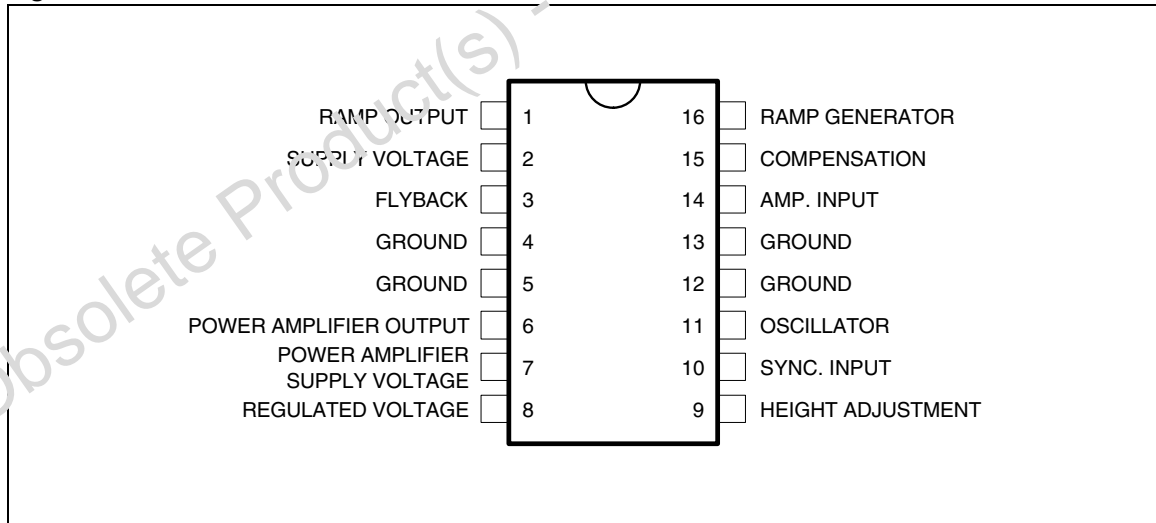

Figure 2. Pin Connections



TDA1175P

Figure 3. Block Diagram

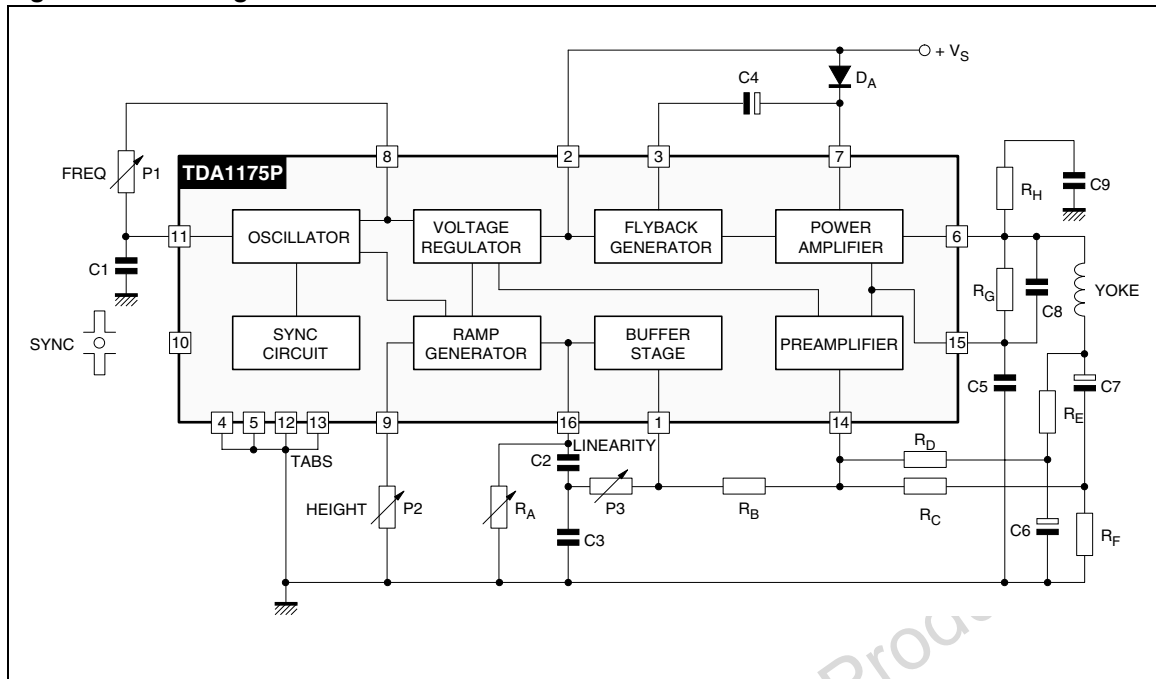

Table 1. Absolute Maximum Ratings

Symbol	Parameter	Value	Unit
V_S	Supply Voltage at Pin 2	35	V
V_6, V_7	Flyback Peak Voltage	60	V
V_{14}	Power Amplifier Input Voltage	+ 10 - 0.5	V
I_O	Output Peak Current (non repetitive) at $t = 2\text{ms}$	2	A
I_O	Output Peak Current at $f = 50\text{Hz}$, $t \leq 10\mu\text{s}$	2.5	A
I_O	Output Peak Current at $f = 50\text{Hz}$, $t > 10\mu\text{s}$	1.5	A
I_3	Pin 3 DC Current at $V_6 < V_2$	100	mA
I_3	Pin 3 Peak to Peak Flyback Current for $f = 50\text{Hz}$, $t_{fly} \leq 1.5\text{ms}$	1.8	A
I_{10}	Pin 10 Current	± 20	mA
P_{TOT}	Power Dissipation at $T_{tab} = 90^\circ\text{C}$	4.3	W
	Power Dissipation at $T_{amb} = 70^\circ\text{C}$ (free air) (1)	1	W
T_{STG}, T_j	Storage and Junction Temperature	- 40 to 150	$^\circ\text{C}$

Table 2. Thermal Data

Symbol	Parameter	Value	Unit
$R_{th(j-tab)}$	Thermal Resistance Junction-pin Max.	12	$^\circ\text{C}/\text{W}$
$R_{th(j-amb)}$	Thermal Resistance Junction-ambient Max.	80	$^\circ\text{C}/\text{W}^{(1)}$

Note: 1. Obtained with tabs soldered to printed circuit with minimized copper area.

ELECTRICAL CHARACTERISTICS(T_{amb} = 25°C, unless otherwise specified)**Table 3. DC CHARACTERISTICS**(Refer to the test circuits, V_S = 35V)

Symbol	Parameter	Test Conditions	Min.	Typ.	Max.	Unit	Fig.
I ₂	Pin 2 Quiescent Current	I ₃ = 0		7	14	mA	5
I ₇	Pin 7 Quiescent Current	I ₆ = 0		8	17	mA	5
-I ₁₁	Oscillator Bias Current	V ₁₁ = 1V		0.1	1	μA	4
-I ₁₄	Amplifier Input Bias Current	V ₁₄ = 1V		1	10	μA	5
-I ₁₆	Ramp Generator Bias Current	V ₁₆ = 0		0.02	0.3	μA	4
-I ₁₆	Ramp Generator Current	I ₉ = 20μA, V ₁₆ = 0	18.5	20	21.5	μA	5
$\frac{\Delta I_{16}}{I_{16}}$	Ramp Generator Non-linearity	ΔV ₁₆ = 0 to 12V, I ₉ = 20μA		0.2	1	%	5
V _S	Supply Voltage Range		10		35	V	
V ₁	Pin 1 Saturation Voltage to Ground	I ₁ = 1mA		1	14	V	
V ₃	Pin 3 Saturation Voltage to Ground	I ₃ = 10mA		1.5	2.5	V	4
V ₆	Quiescent output Voltage	V _S = 10V, R1 = 1kΩ, R2 = 1kΩ V _S = 35V, R1 = 3kΩ, R2 = 1kΩ	4.1 8.2	4.4 8.8	4.7 9.4	V V	4 4
V _{6L}	Output Saturation Voltage to Ground	- I ₆ = 0.1A - I ₆ = 0.8A		0.9 1.8	1.2 2.2	V V	6 6
V _{6H}	Output Saturation Voltage to Supply	I ₆ = 0.1A I ₆ = 0.8A		1.4 2.8	2.1 3.1	V V	7 7
V ₈	Regulated Voltage at Pin 8		6.5	6.7	6.9	V	5
V ₉	Regulated Voltage at Pin 9	I ₉ = 20μA	6.6	6.8	7	V	5
$\frac{ \Delta V_8 }{\Delta V_S} \quad \frac{ \Delta V_9 }{\Delta V_S}$	Regulated Voltage Drift with Supply Voltage	ΔV _S = 10 to 35V		1	2	mV/V	5
V ₁₄	Amplifier Input Reference Voltage	V ₁₀ ≤ 0.4V	2.20	2.27	2.35	V	

Table 4. AC CHARACTERISTICS(Refer to the AC test circuit, $V_S = 22V$, $f = 50Hz$)

Symbol	Parameter	Test Conditions	Min.	Typ.	Max.	Unit	Fig.
I_S	Supply Current	$I_Y = 1_{APP}$		140		mA	8
I_{10}	Sync. Input Current (positive or negative)		0.5		2	mA	8
V_6	Flyback Voltage	$I_Y = 1_{APP}$		45		V	8
t_{fly}	Flyback Time	$I_Y = 1_{APP}$		0.7		ms	8
V_{ON}	Peak to Peak Output Noise	Pin 11 Connected to GND		18	30	mV _{pp}	8
f_O	Free Running Frequency	(P1 + R1) = 300k Ω C9 = 0.1 μ F	36	43.5		Hz	8
f_{OPER}	Operating Frequency Range		10		120	Hz	8
Δf	Synchronization Range	$I_{10} = 0.5mA$, C9 = 0.1 μ F (P1+R1) = 300k Ω	14			Hz	8
$\frac{\Delta f}{\Delta V_S}$	Frequency Drift with Supply Voltage	$V_S = 10$ to 35V		0.00 5		Hz/V	8
$\frac{ \Delta f }{\Delta T_{ab}}$	Frequency Drift with tab Temperature	$T_{tab} = 40$ to 120 $^{\circ}C$		0.01		Hz/ $^{\circ}C$	8

DC TEST CIRCUITS

Figure 4.

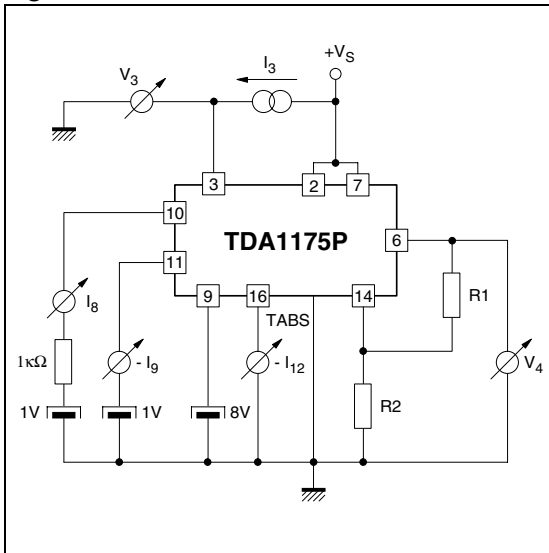

Figure 6.

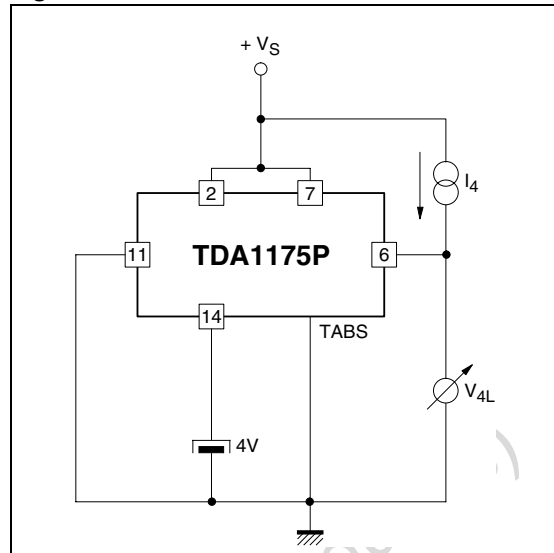

Figure 5.

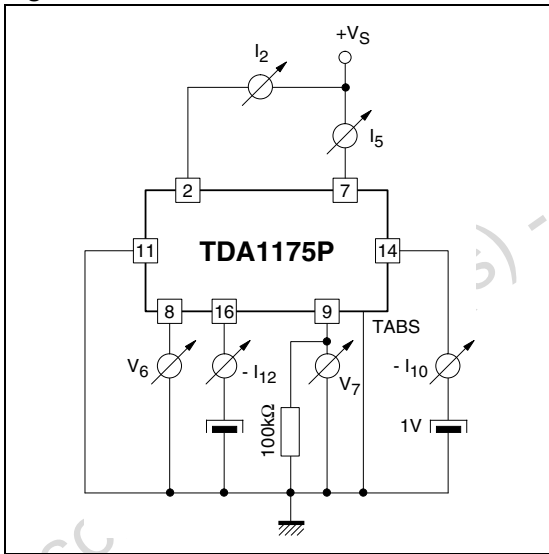
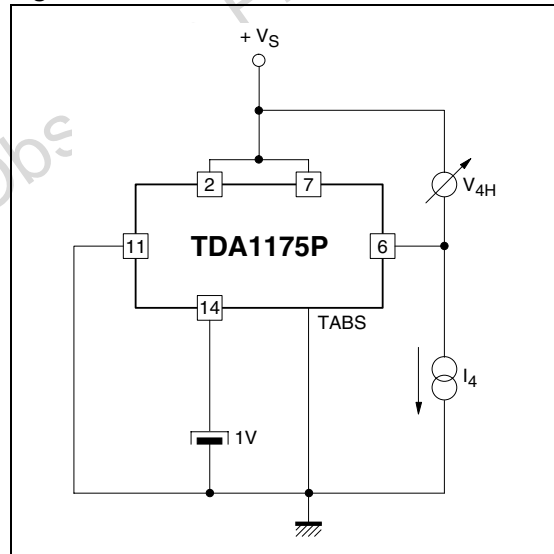

Figure 7.



TDA1175P

Figure 8. AC Test and Application Circuit for Large Screen B/W TV Set 10Ω/20mH/1A_{pp}

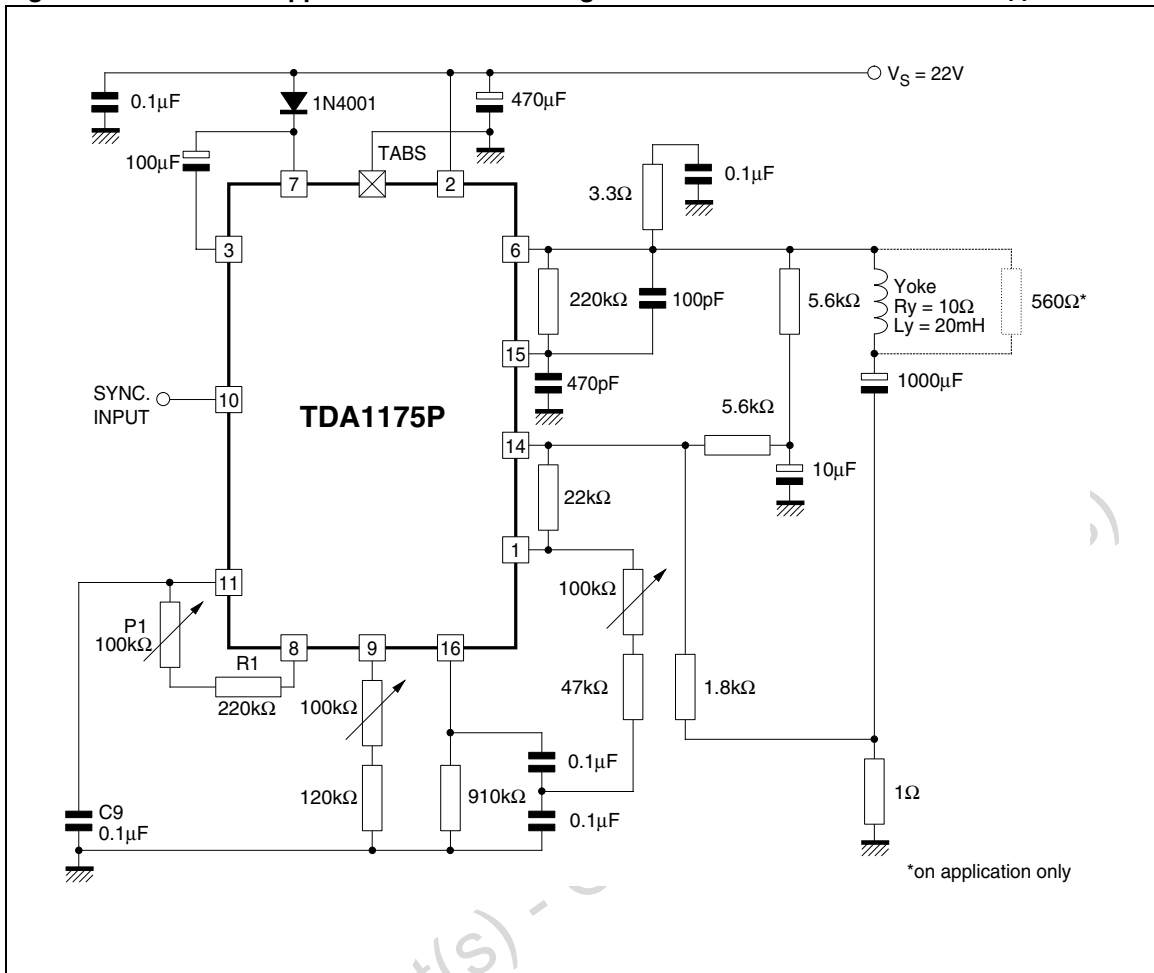

Figure 9. Typical Application Circuit for VGA Monitor ($R_Y = 10\Omega$, $L_Y = 20mH$, $I_Y = 0.8A_{pp}$)

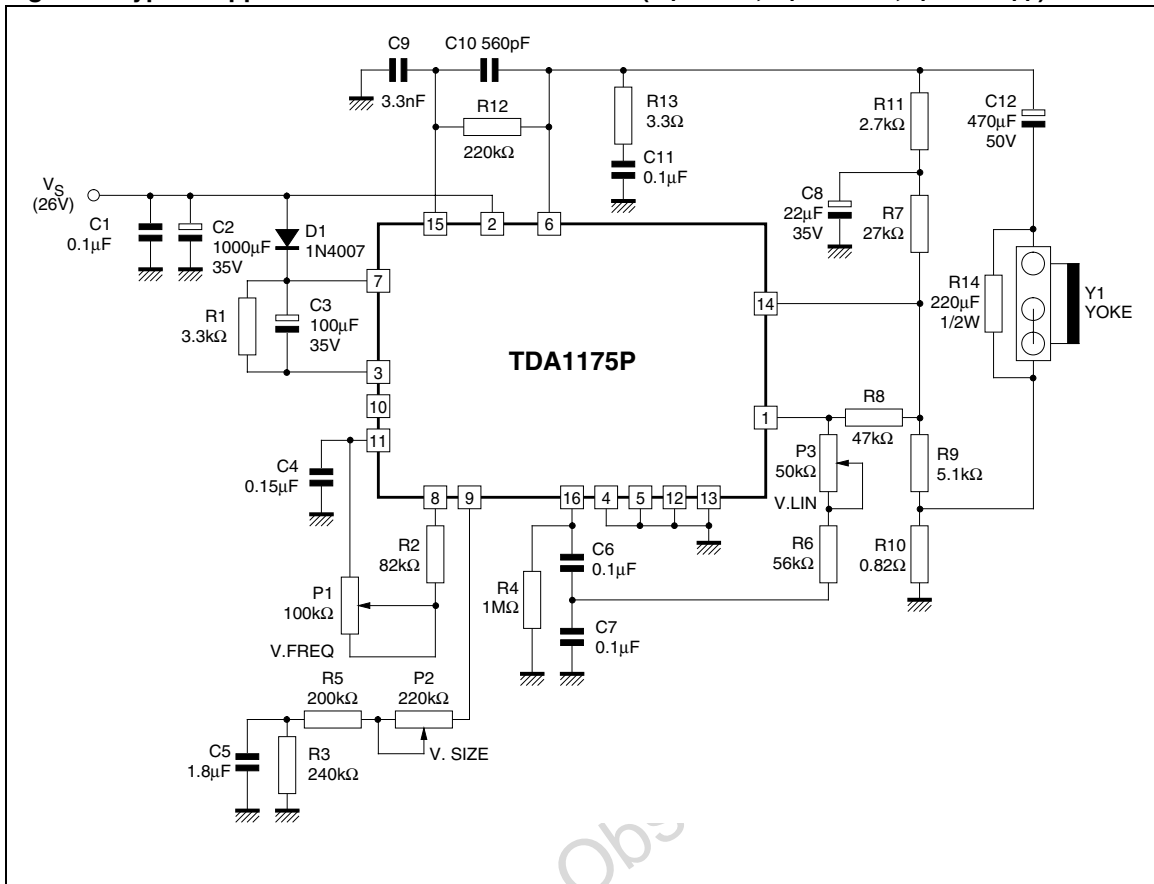

Figure 10. P.C. Board and Components Layout of the Circuit of Figure 9 (1:1 scale)

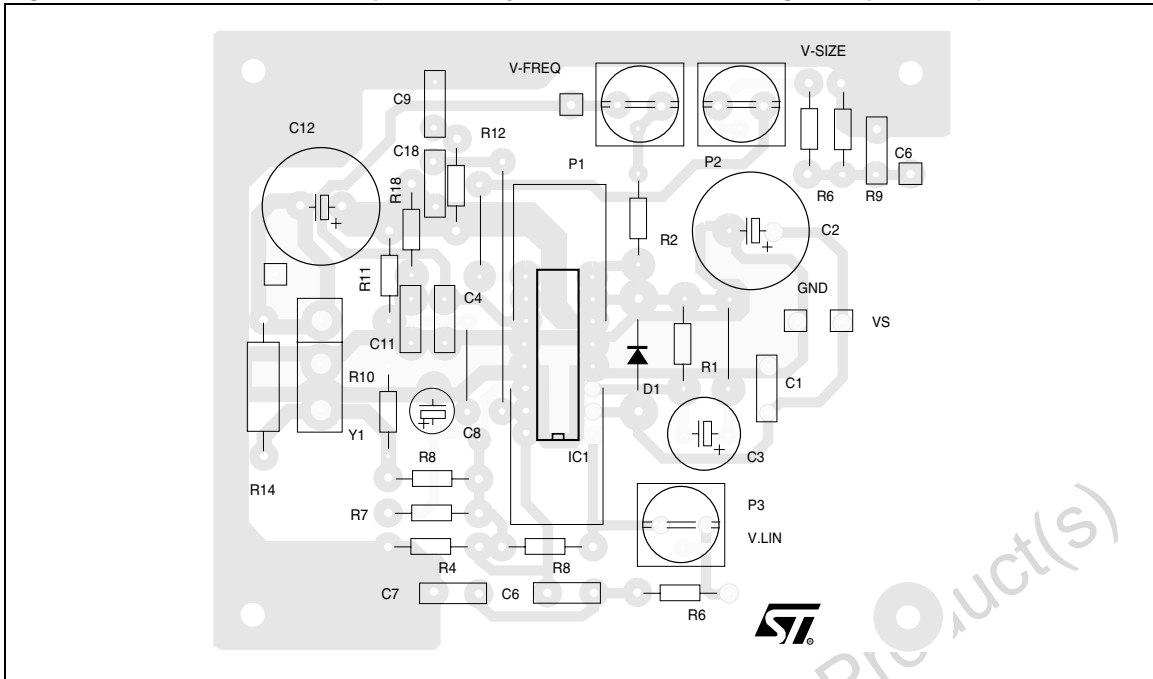

Table 5. Bill of Material

Item	Qty	Reference	Part
1	4	C1, C6, C7, C11	0.1 μ F
2	1	C2	1000 μ F 35V
3	1	C3	100 μ F 35V
4	1	C4	0.15 μ F
5	1	C5	1.8nF
6	1	C8	22 μ F 35V
7	1	C9	3.3nF
8	1	C10	560pF
9	1	C12	470 μ F 50V
10	1	D1	1N4007
11	1	IC1	TDA1175P
12	1	P1	100k Ω POT
13	1	P2	220k Ω POT
14	1	P3	50k Ω POT

Item	Qty	Reference	Part
15	1	R1	3.3k Ω
16	1	R2	82k Ω
17	1	R3	240k Ω
18	1	R4	1M Ω
19	1	R5	200k Ω
20	1	R6	56k Ω
21	1	R7	27k Ω
22	1	R8	47k Ω
23	1	R9	5.1k Ω
24	1	R10	0.82 Ω
25	1	R11	2.7k Ω
26	1	R12	220k Ω
27	1	R13	3.3 Ω
28	1	R14	220 Ω 1/2W
29	1	Y1	YOKE

MOUNTING INSTRUCTION

The $R_{th(j-a)}$ can be reduced by soldering the GND pins to a suitable copper area of the printed circuit board (Figure 11) or to an external heatsink (Figure 12).

The diagram of Figure 13 shows the maximum dissippable power P_{tot} and the $R_{th(j-a)}$ as a function of the side "l" of two equal square copper areas having a thickness of 35μ (1.4 mils).

During soldering the pins temperature must not exceed 260°C and the soldering time must not be longer than 12 seconds.

The external heatsink or printed circuit copper area must be connected to electrical ground.

Figure 11. Example of P.C. Board Copper Area

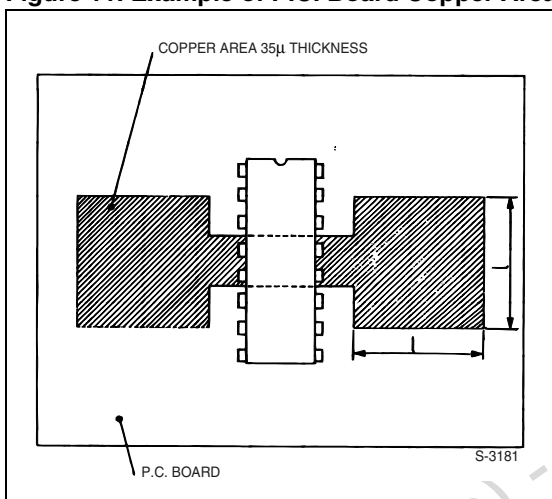

Figure 12. External Heatsink Mounting Example

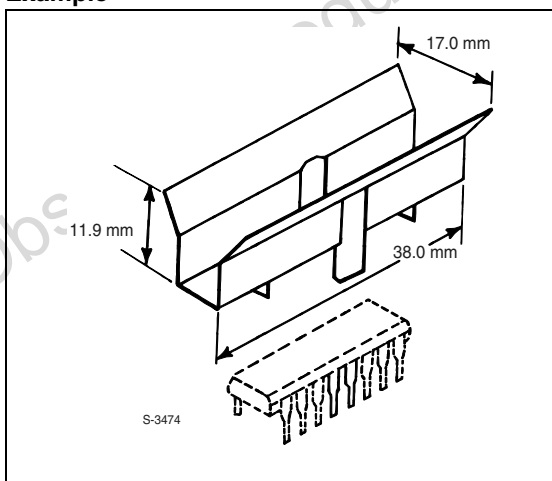

Figure 13. Maximum Power Dissipation and Junction-ambient Thermal Resistance versus "l"

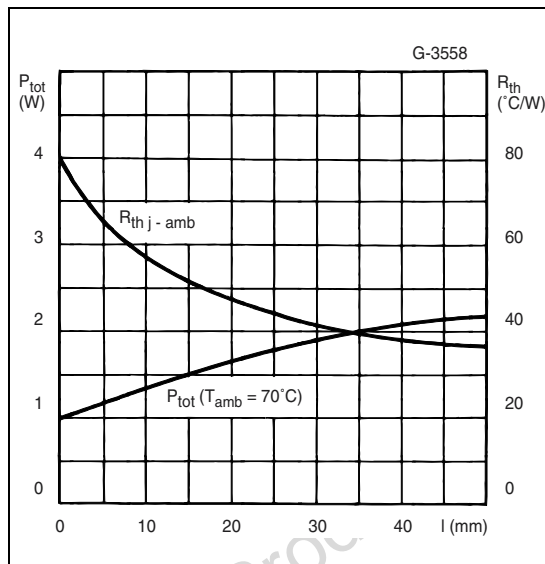
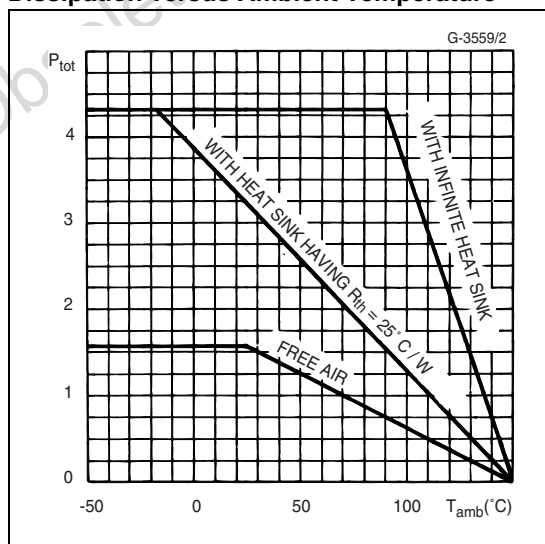

Figure 14. Maximum Allowable Power Dissipation versus Ambient Temperature



TDA1175P

PART NUMBERING

Table 6. Order Codes

Part Number	Package	Temperature Range
TDA1175P	POWERDIP16	-25 to 85 °C

Obsolete Product(s) - Obsolete Product(s)

PACKAGE MECHANICAL

Table 7. POWERDIP16 - Mechanical Data

Symbol	millimeters			inches		
	Typ	Min	Max	Typ	Min	Max
a1	0.51			0.020		
B	0.85		1.4	0.033		0.055
b		0.5			0.020	
b1	0.38		0.5	0.015		0.020
D			20			0.787
E		8.8			0.346	
e		2.54			0.100	
e3		17.78			0.700	
F			7.1			0.280
i			5.1			0.201
L		3.3			0.130	
Z			1.27			0.050

Figure 15. POWERDIP16 - Package Dimensions

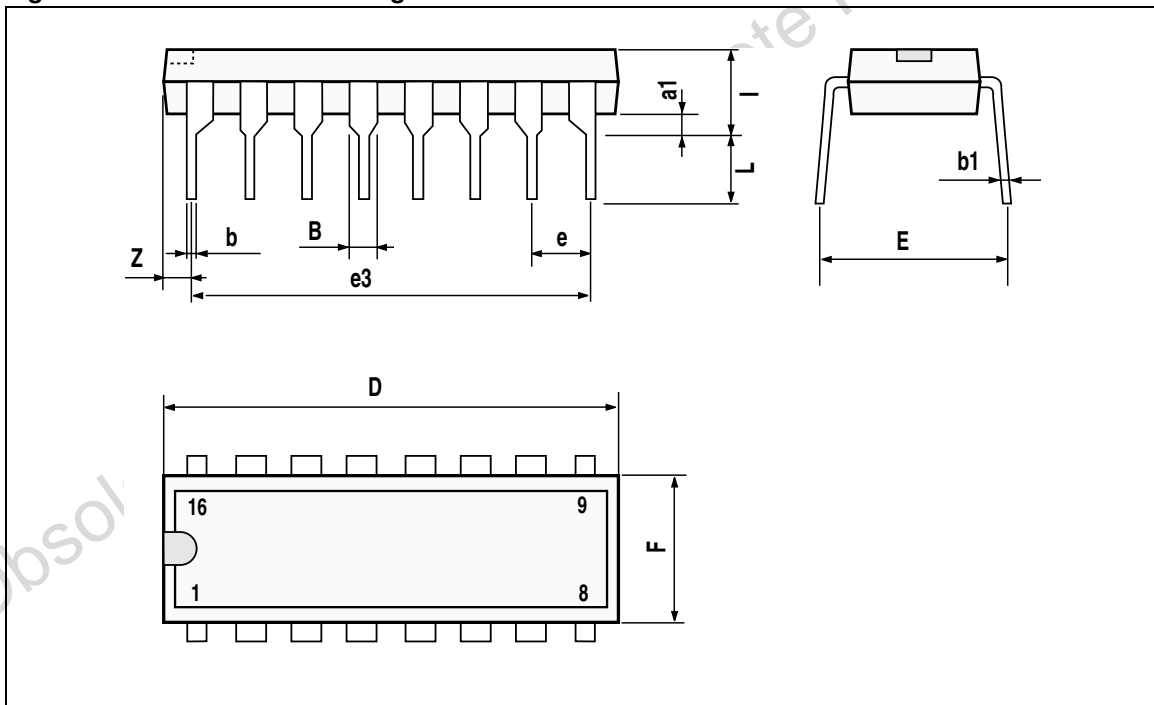

Note: Drawing is not to scale

REVISION HISTORY

Table 8. Revision History

Date	Revision	Description of Changes
August-1995	1	First Issue
14-Apr-2004	2	Stylesheet update. No content change.

Obsolete Product(s) - Obsolete Product(s)

Information furnished is believed to be accurate and reliable. However, STMicroelectronics assumes no responsibility for the consequences of use of such information nor for any infringement of patents or other rights of third parties which may result from its use. No license is granted by implication or otherwise under any patent or patent rights of STMicroelectronics. Specifications mentioned in this publication are subject to change without notice. This publication supersedes and replaces all information previously supplied. STMicroelectronics products are not authorized for use as critical components in life support devices or systems without express written approval of STMicroelectronics.

The ST logo is a registered trademark of STMicroelectronics.
All other names are the property of their respective owners

© 2004 STMicroelectronics - All rights reserved

STMicroelectronics GROUP OF COMPANIES

Australia - Belgium - Brazil - Canada - China - Czech Republic - Finland - France - Germany - Hong Kong - India - Israel - Italy - Japan -
Malaysia - Malta - Morocco - Singapore - Spain - Sweden - Switzerland - United Kingdom - United States

www.st.com

