

VIDEO CELLULAR MATRIX

- 6 Video Inputs - 8 Video Outputs
- 2 Internal Selectable YC Adders
- 15MHz Bandwidth @ -3dB
- Selectable 0.5/6.5dB Gain FOR EACH Output
- High Impedance Switch for each Output (3-state operation)
- Programmable Clamp Mode on each Input (sync bottom or average value)
- -60dB Crosstalk @ 5MHz
- 4 Sub-address Capability
- I²C Bus Control

DESCRIPTION

This device is intended for switching between video and chroma signals such as CVBS, SVHS, baseband CVBS, MAC. Each input clamp mode, each output gain, all switching are controlled through the I²C bus. The 8 outputs can be set separately in high impedance state, to enable parallel DC connection of several devices (up to 4).

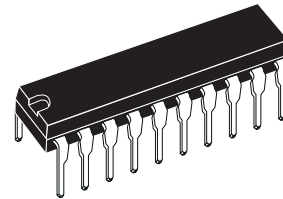

**DIP20
(Plastic Package)**

ORDER CODE: TEA6425

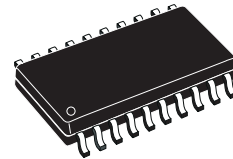

**SO20L
(Plastic Micropackage)**

ORDER CODE: TEA6425D

Figure 1. Pin Connections

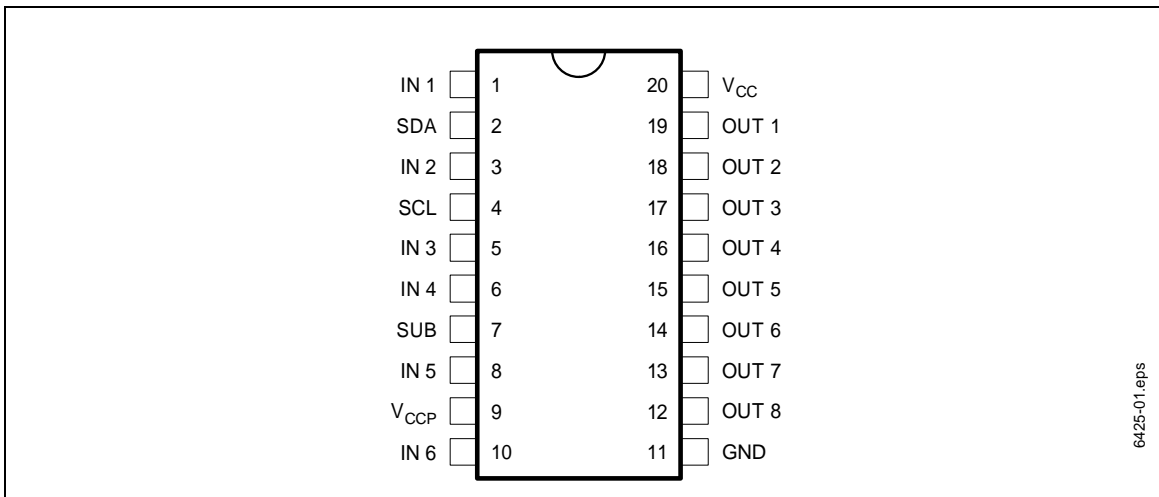

6425-01.eps

TEA6425

Figure 2. Block Diagram

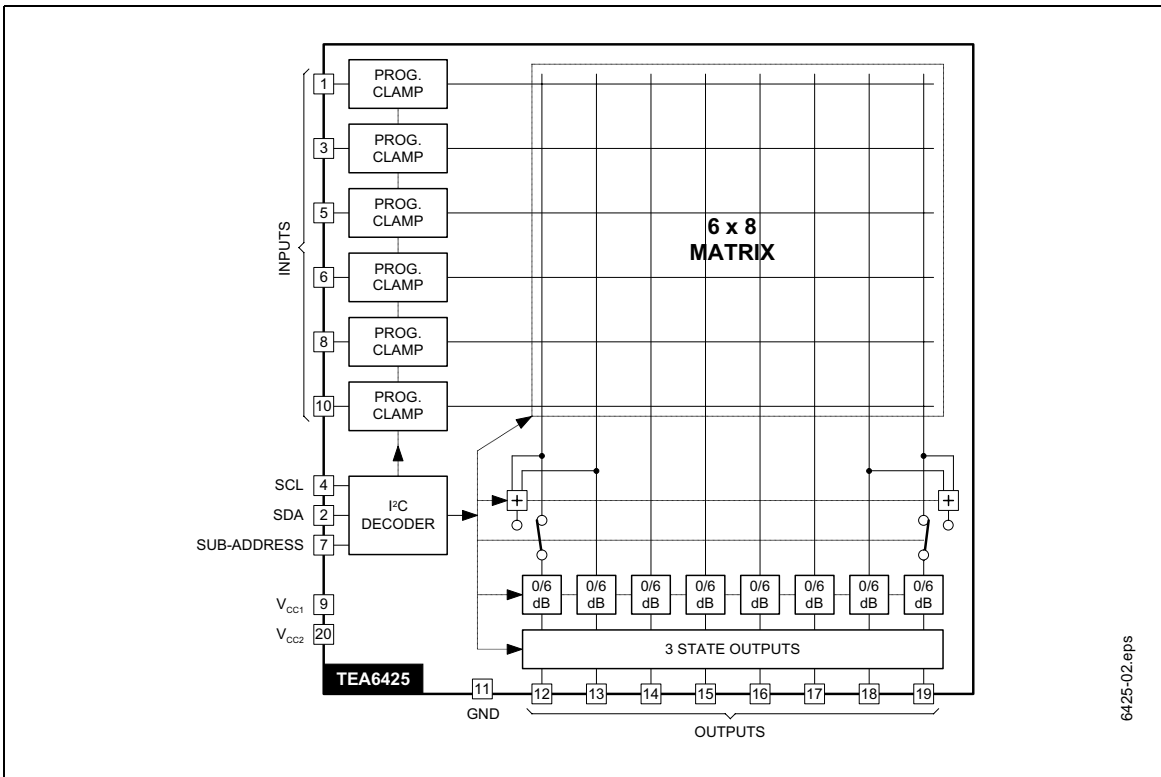

6425-02.eps

Figure 3. Cellular Matrix Connections

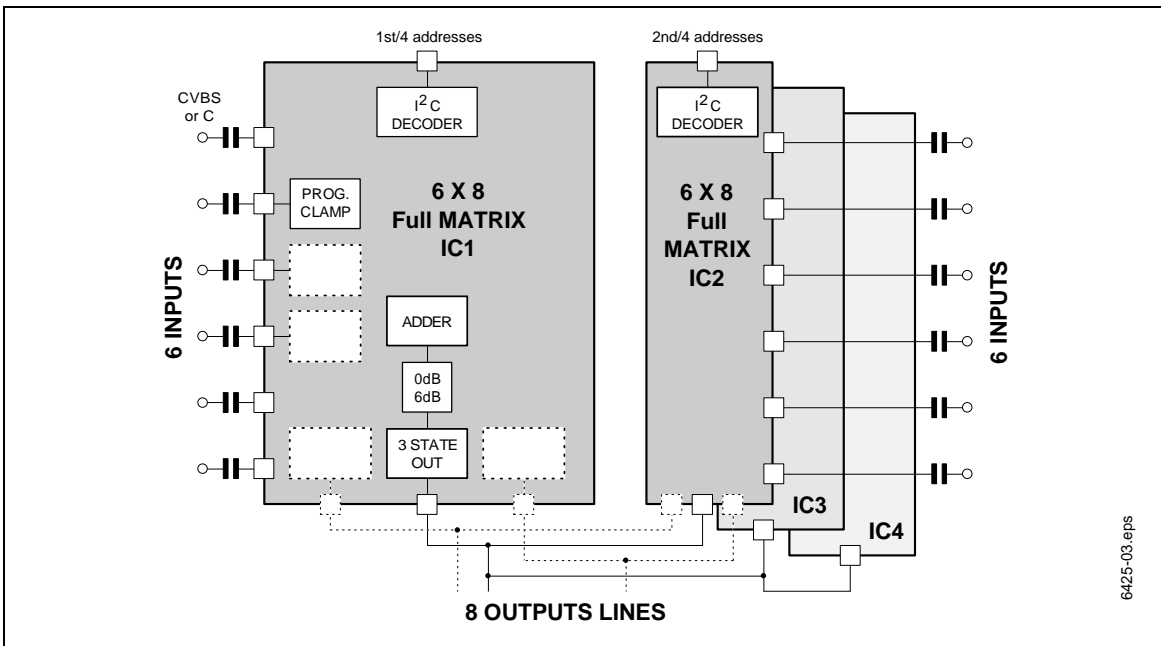

6425-03.eps

ABSOLUTE MAXIMUM RATINGS

Symbol	Parameter	Value	Unit
V_{CC}	Supply Voltage	12	V
V_i	Voltage at Pin i to GND	0, V_{CC}	V
T_{oper}	Operating Ambient Temperature	0, + 70	°C
T_{stg}	Storage Temperature	-20, + 150	°C

THERMAL DATA

Symbol	Parameter	Value	Unit
$R_{th(j-a)}$	Junction-ambient Thermal Resistance	Min. 80	°C/W

ELECTRICAL CHARACTERISTICS ($V_{CC} = 8V$, $T_{amb} = 25^{\circ}C$, $V_{IN} = 1V$, Gain = 6.5dB, $C_{load} = 20pF$, $R_{load} = 4.7k\Omega$; Gain condition, clamp and 3-state are controlled by I²C bus, unless otherwise specified)

Symbol	Parameter	Test Conditions	Min.	Typ.	Max.	Unit
SUPPLY						
V_{CC}	Supply Voltage		7.2	8	8.8	V
I_{CC}	Supply Current			45	60	mA
RR	Supply Voltage Rejection	f = 1kHz	40	46		dB
VIDEO INPUTS (clamping at bottom sync level)						
V_{IN}	Max. Signal Amplitude	Clamp Active	2			V_{PP}
V_{clamp}	Clamp Level	Clamp Active	1.7	2	2.3	V
V_{DC}	Input DC Level	Clamp Inactive	2.7	3	3.3	V
I_{IN}	Leakage Current	1 input connected to 1 output		2	5	μA
I_{clamp}	Clamp Current	$V_{clamp} - 200mV$		0.9	3	mA
VIDEO OUTPUTS						
R_{OUT}	Output Resistance			15	50	W
Z_{HI}	Output "off" Impedance	no load	50			kΩ
C_{HI}	C_{OUT} in 3-state	no load		3		pF
G1	Voltage Gain	f = 100kHz	0	0.5	1	dB
G2	Voltage Gain	f = 100kHz	6	6.5	7	dB
V_{sync}	Top Level Sync (Y or CVBS)	G = 6.5dB, Clamp Active	1	1.25	2	V
V_{bias}	Output Mean Level (chroma)	G = 0.5dB, Clamp Inactive	2	2.4	3	V
		G = 6.5dB, Clamp Inactive	3	3.4	4	V
	Isolation "off" State	f = 5MHz	60			dB
	Crosstalk Attenuation between Channels	f = 5MHz	50	60		dB
B	Bandwidth	$C_{load} = 20pF$, G = 6.5dB at ± 0.5dB at ± 1dB at - 3dB		5 10 21		MHz

FUNCTIONAL DESCRIPTION

This device is controlled via the I²C bus. 4 addresses can be selected by a 4-level detector on Pin 7, thus enabling parallel connection of 4 devices.

Via the I²C bus :

- The input signals can be clamped at their negative peak (top sync).
- The gain factor of the outputs can be selected between 0.5 and 6.5dB.

- Each of the 6 inputs can be connected to the 8 outputs.

- Each output can individually be set in a high impedance state.

Two internal SVHS mixers will add the selected Y and C inputs. Two dedicated outputs will have the option to select this added signal also.

TEA6425

I²C BUS CHARACTERISTICS

Symbol	Parameter	Test Conditions	Standard Mode		Fast Mode		Unit
			Min.	Max.	Min.	Max.	
SCL							
V _{IL}	Low Level Input Voltage		- 0.3	+ 1.5	- 0.3	+ 1.5	V
V _{IH}	High Level Input Voltage		3.0	V _{CC} + 0.5	3.0	V _{CC} + 0.5	V
I _{LI}	Input Leakage Current	V _I = 0 to V _{DD}	- 10	+ 10	- 10	+ 10	μA
f _{SCL}	Clock Frequency		0	100	0	400	kHz
t _R	Input Rise Time	1.5V to 3V		1000		300	ns
t _F	Input Fall Time	1.5V to 3V		300		300	ns
C _I	Input Capacitance			10		10	pF
SDA							
V _{IL}	Low Level Input Voltage		- 0.3	+ 1.5	- 0.3	+ 1.5	V
V _{IH}	High Level Input Voltage		3.0	V _{CC} + 0.5	3.0	V _{CC} + 0.5	V
I _{LI}	Input Leakage Current	V _I = 0 to V _{DD}	- 10	+ 10	- 10	+ 10	μA
C _I	Input Capacitance			10		10	pF
t _R	Input Rise Time	1.5V to 3V		1000		300	ns
t _F	Input Fall Time	1.5V to 3V		300		300	ns
V _{OL}	Low Level Output Voltage	I _{OL} = 3mA		0.4		0.4	V
t _F	Output Fall Time	3V to 1.5V		250		250	ns
C _L	Load Capacitance			400		400	pF
TIMING							
t _{LOW}	Clock Low Period		4.7		1.3		μs
t _{HIGH}	Clock High Period		4.0		0.6		μs
t _{SU, DAT}	Data Set-up Time		250		100		ns
t _{HD, DAT}	Data Hold Time		0	340	0	340	ns
t _{SU, STO}	Set-up Time from Clock High to Stop		4.0		0.6		μs
t _{BUF}	Start Set-up Time following a Stop		4.7		1.3		μs
t _{HD, STA}	Start Hold Time		4.0		0.6		μs
t _{SU, STA}	Start Set-up Time following Clock Low-to-High Transition		4.7		0.6		μs

Figure 4. I²C Bus Timing

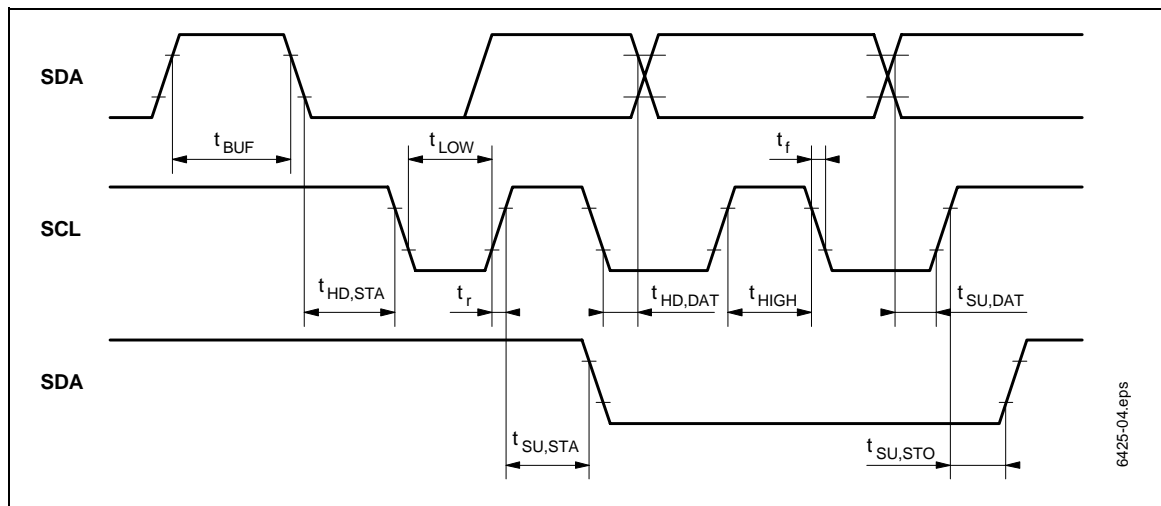

I²C BUS SELECTION**I²C Bus Slave Address**

Address	A6	A5	A4	A3	A2	A1	A0	R/W
Value	1	0	0	1	0	A 1	A0	0

I²C Sub-Address

Symbol	Parameter	Conditions	Pin 7 Voltage (Typ)	Unit
Vsub	Slave address HEXA	Sub-address (see note)		
		A1 A0		
1	90	0 0	GND	V
2	96	1 1	V _{CC}	V
3	94	1 0	1/3	V _{CC}
4	92	0 1	2/3	V _{CC}

Note: The first 3 levels are defined by connecting the sub-address pin to the appropriate level. Sub-address 4 will be selected when this pin is left open.

1st Data Byte

	b7	b6	b5	b4	b3	b2	b1	b0	Selected Output
	a2	a1	a0	*	*	*	*	1	
Output Select	0	0	0	*	*	*	*	0	OUT1
	0	0	1	*	*	*	*	0	OUT2
	0	1	0	*	*	*	*	0	OUT3
	0	1	1	*	*	*	*	0	OUT4
	1	0	0	*	*	*	*	0	OUT5
	1	0	1	*	*	*	*	0	OUT6
	1	1	0	*	*	*	*	0	OUT7
	1	1	1	*	*	*	*	0	OUT8

2nd Data Byte

	b7	b6	b5	b4	b3	b2	b1	b0	Selected Output
	a2	a1	a0	*	*	*	*	1	
Input Select	0	0	0	*	*	*	*	1	IN1
	0	0	1	*	*	*	*	1	IN2
	0	1	0	*	*	*	*	1	IN3
	0	1	1	*	*	*	*	1	IN4
	1	0	0	*	*	*	*	1	IN5
	1	0	1	*	*	*	*	1	IN6
Clamp	*	*	*	0	*	*	*	1	Free
	*	*	*	1	*	*	*	1	Clamped
Gain	*	*	*	*	0	*	*	1	0.5dB
	*	*	*	*	1	*	*	1	6.5dB
Mixer	*	*	*	*	*	0	*	1	Disabled
	*	*	*	*	*	1	*	1	Enabled
Tri-state	*	*	*	*	*	*	0	1	Low impedance
	*	*	*	*	*	*	1	1	Tri-state

Power-on-Reset

When active: outputs in 3-state, inputs are clamped

Symbol	Parameter	Test Conditions	Min.	Typ.	Max.	Unit
Reset	Start of Reset	Incr. V _{CC}			2.5	V
		Decr. V _{CC}			4.2	V
	End of Reset	Incr. V _{CC}	4.5			V

TEA6425

PIN CONFIGURATIONS

Figure 5. Video IN

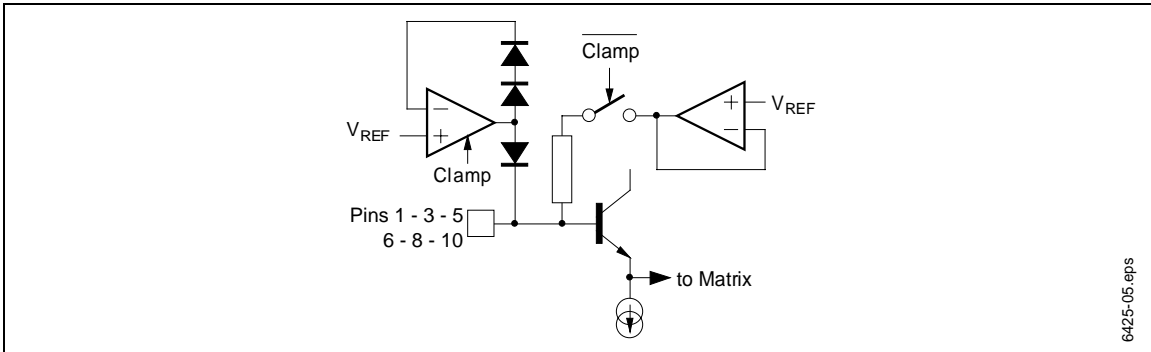

6425-05.eps

Figure 6. Video OUT

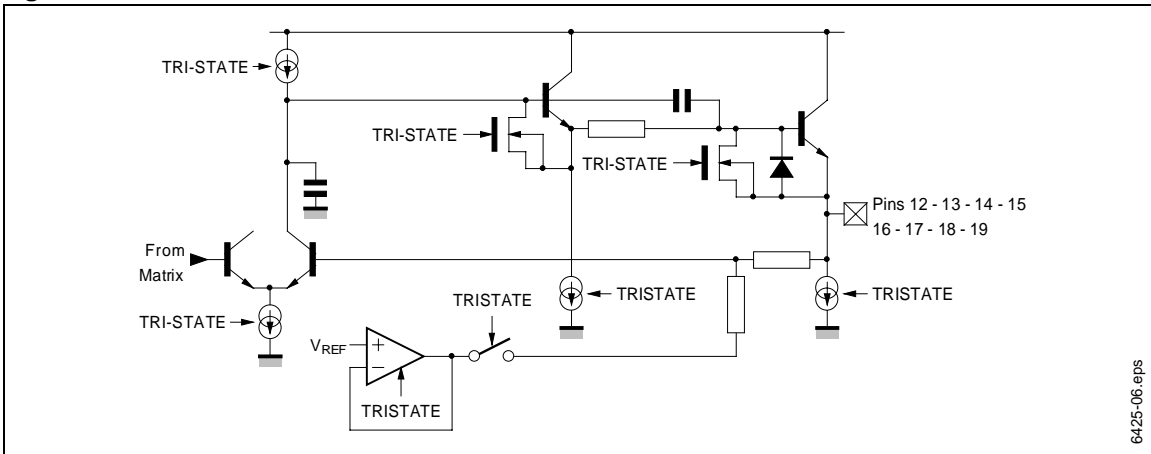

6425-06.eps

Figure 7. PROG Pin

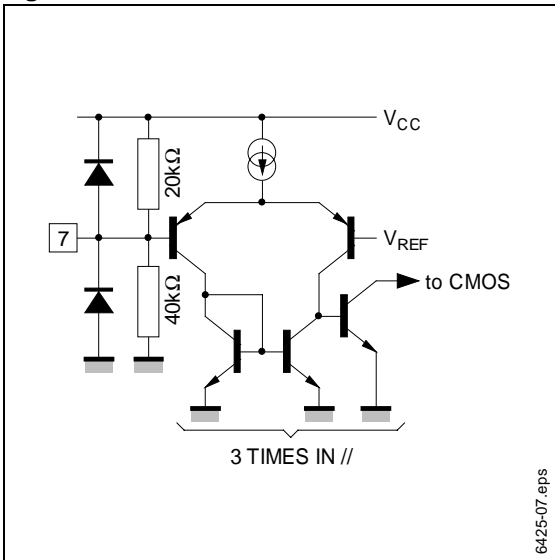

6425-07.eps

Figure 8. Bus Inputs

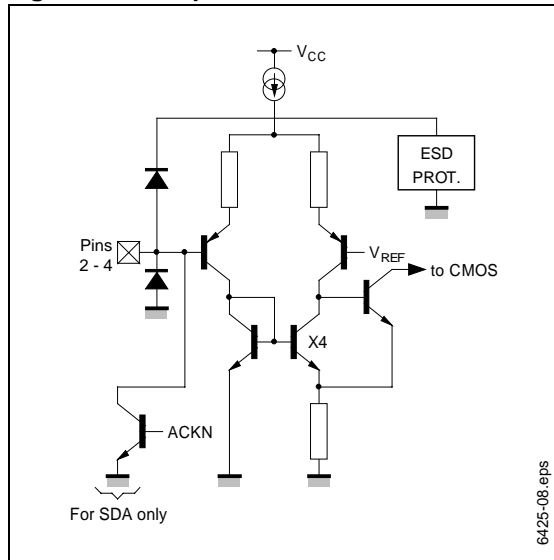

6425-08.eps

Figure 9. Typical Application

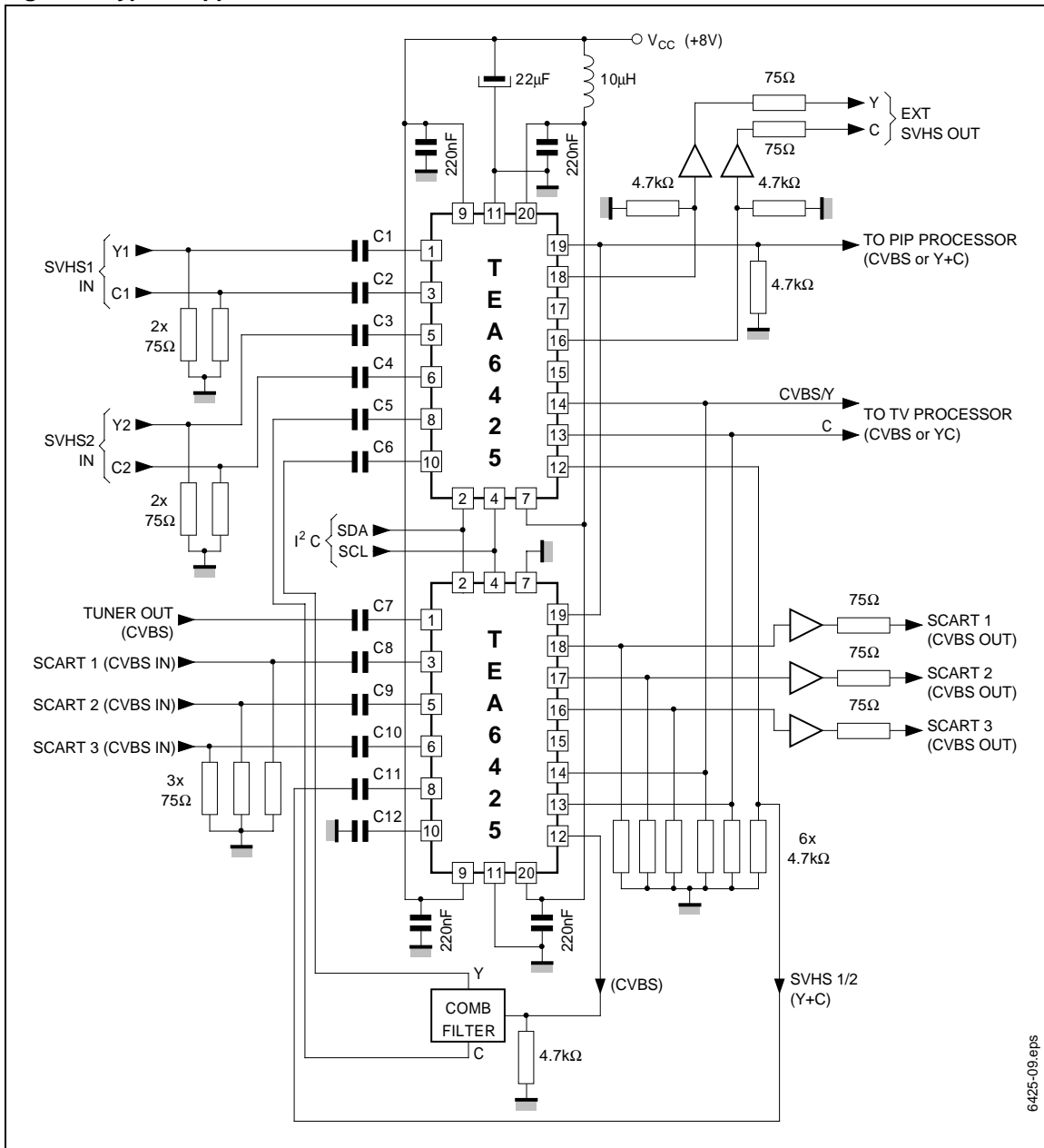

TEA6425

PACKAGE MECHANICAL DATA

20 PINS - PLASTIC DIP

Figure 10. 20-Pin Package

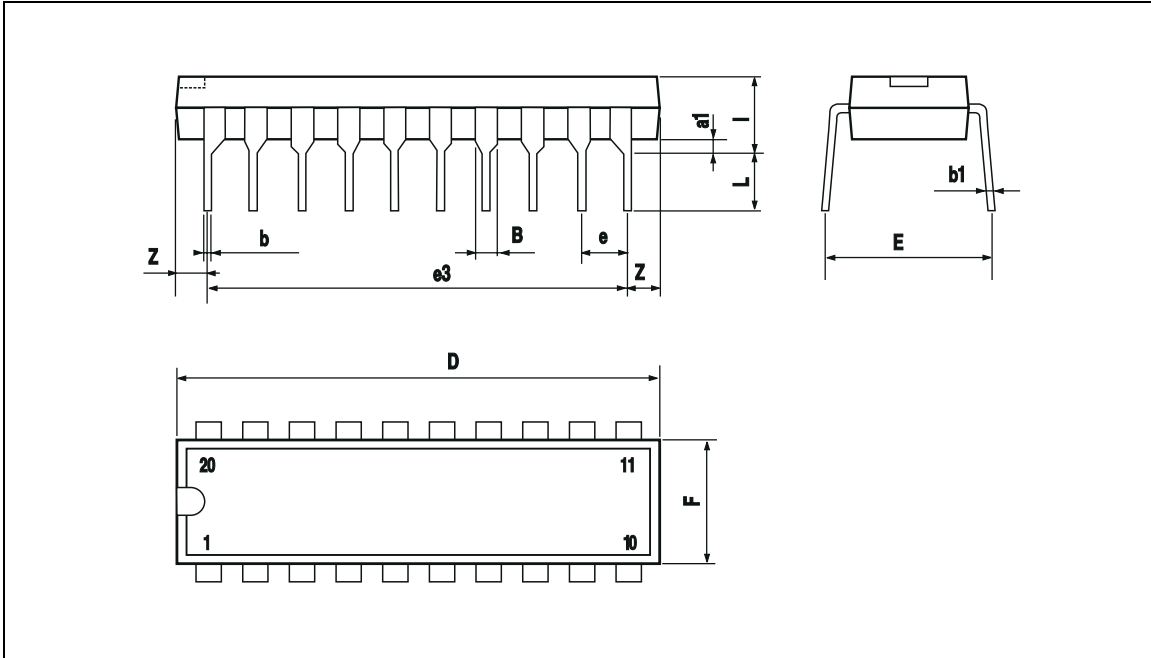

PACKAGE MECHANICAL DATA (Cont'd)
20 PINS - PLASTIC MICROPACKAGE

Figure 11. 20-Pin Package

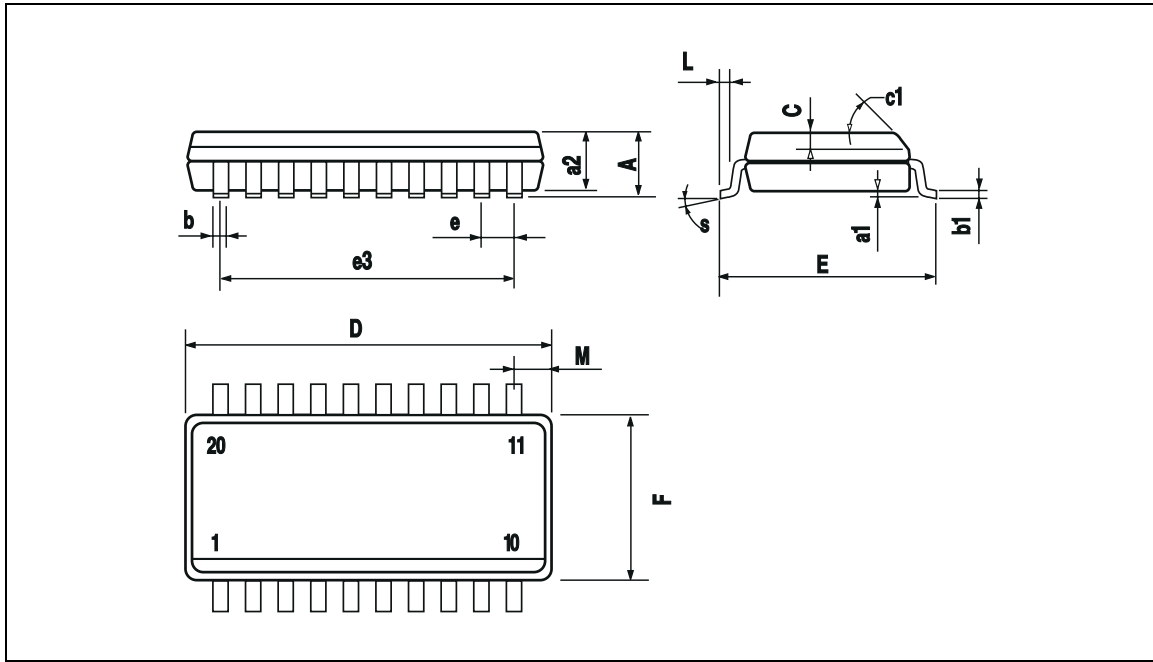

Information furnished is believed to be accurate and reliable. However, STMicroelectronics assumes no responsibility for the consequences of use of such information nor for any infringement of patents or other rights of third parties which may result from its use. No license is granted by implication or otherwise under any patent or patent rights of STMicroelectronics. Specifications mentioned in this publication are subject to change without notice. This publication supersedes and replaces all information previously supplied. STMicroelectronics products are not authorized for use as critical components in life support devices or systems without the express written approval of STMicroelectronics.

The ST logo is a registered trademark of STMicroelectronics

©2003 STMicroelectronics - All Rights Reserved.

Purchase of I²C Components by STMicroelectronics conveys a license under the Philips I²C Patent. Rights to use these components in an I²C system is granted provided that the system conforms to the I²C Standard Specification as defined by Philips.

STMicroelectronics Group of Companies

Australia - Brazil - China - Finland - France - Germany - Hong Kong - India - Italy - Japan - Malaysia - Malta - Morocco - Singapore - Spain
Sweden - Switzerland - United Kingdom - U.S.A.

<http://www.st.com>