

Video signal switcher for AV amplifiers

BA7625

The BA7625 is a video signal switch that contains two five-channel analog multiplexers and wide-band 6dB amplifiers. It is designed for use in video cassette recorders. By simply adding transistor buffers to the outputs, it is possible to construct a record / playback switch for two record / playback VCRs, and three video playback machines (eg. laser disk players). Input switching and VCR record switching can be done independently. The BA7625 has sync-tip clamp inputs which are ideal for switching video signals.

● Applications

AV amplifiers and video selectors

● Features

- 1) 5-input / 3-output switches.
- 2) Sync-tip clamp inputs.
- 3) Built-in 6dB amplifiers.
- 4) 5V supply voltage.

● Absolute maximum ratings (Ta = 25°C)

Parameter	Symbol	Limits	Unit
Power supply voltage	V _{cc}	9	V
Power dissipation	P _d	500*	mW
Operating temperature	T _{opr}	- 25 ~ + 70	°C
Storage temperature	T _{stg}	- 55 ~ + 125	°C

* Reduced by 5mW for each increase in Ta of 1°C over 25°C.

●Block diagram

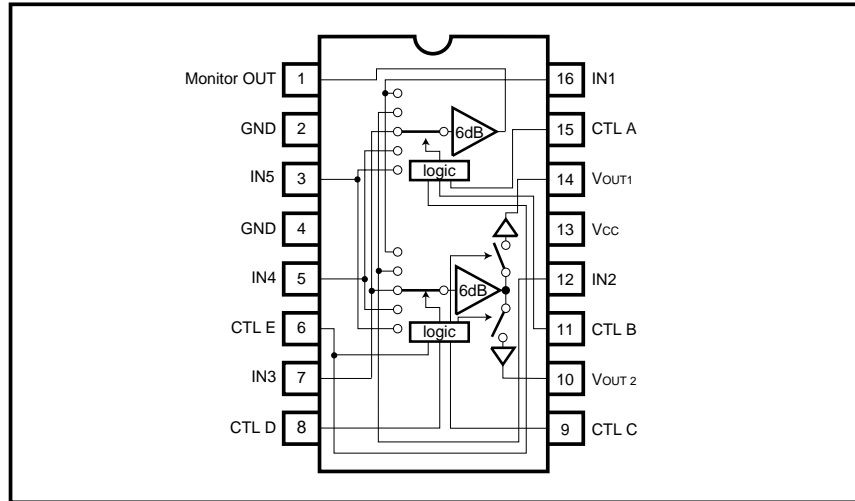

●Truth table

A	B	E	Monitor OUT
L	L	*	IN1
H	L	*	IN2
L	H	*	IN3
H	H	L	IN4
H	H	H	IN5

C	D	E	V _{OUT1}
L	L	*	—
H	L	*	IN2
L	H	*	IN3
H	H	L	IN4
H	H	H	IN5

C	D	E	V _{OUT2}
L	L	*	IN1
H	L	*	—
L	H	*	IN3
H	H	L	IN4
H	H	H	IN5

Note 1: * indicates "don't care" (H or L).

●Equivalent input / output circuits

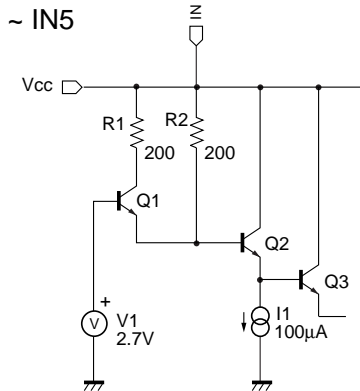
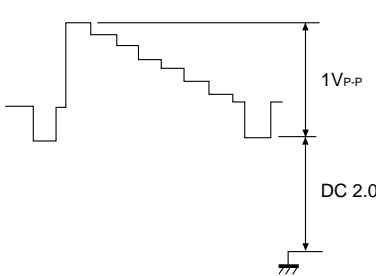
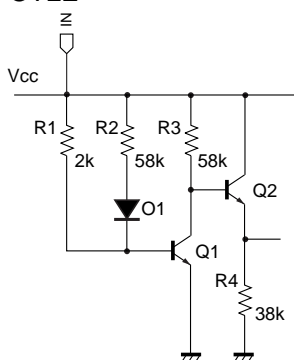
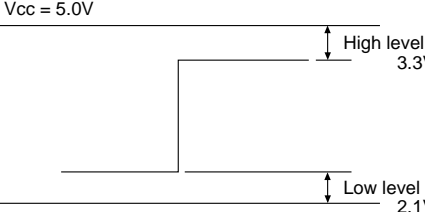
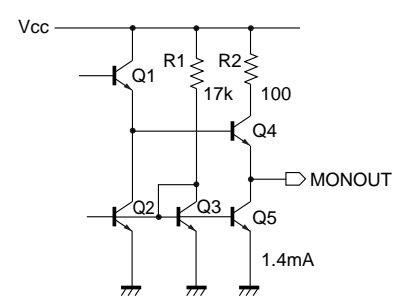
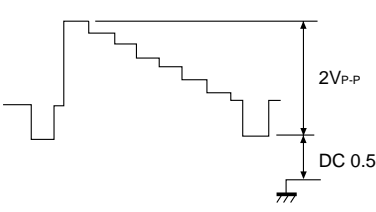
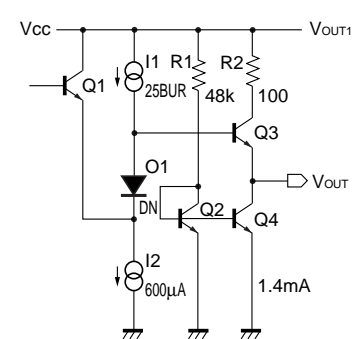
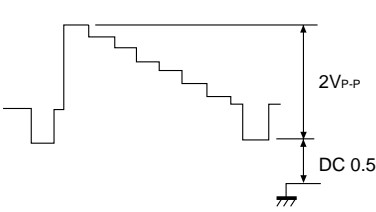
Input circuit	Waveform
<p>IN1 ~ IN5</p> 	 <p>1V_{P-P} DC 2.0V</p>
<p>CTLA ~ CTLE</p> 	<p>V_{CC} = 5.0V</p>  <p>High level 3.3V Low level 2.1V</p>
<p>Monitor OUT</p> 	 <p>2V_{P-P} DC 0.5V</p>
<p>V_{OUT1} , V_{OUT2}</p> 	 <p>2V_{P-P} DC 0.5V</p>

●Electrical characteristics (unless otherwise noted, $T_a = 25^\circ\text{C}$ and $V_{CC} = 5\text{V}$)

Parameter	Symbol	Min.	Typ.	Max.	Unit	Conditions
Operating voltage	V_{CC}	4.5	5.0	5.5	V	—
Supply current	I_{CC}	—	15.0	20.0	mA	—
Maximum output level	V_{om}	2.6	2.9	—	V_{P-P}	$f = 1\text{kHz}$, $\text{THD} = 0.5\%$
Voltage gain	G_V	5.7	6.2	6.7	dB	$f = \text{MHz}$, $V_{IN} = 1V_{P-P}$
Interchannel crosstalk	C_T	—	-65	-45	dB	$f = 4.43\text{MHz}$, $V_{IN} = 1V_{P-P}$
Mute level	CTM	—	-35	-25	dB	$f = 4.43\text{MHz}$, $V_{IN} = 1V_{P-P}$
Frequency characteristic	G_f	-3	0	3	dB	10MHz / 1MHz, $V_{IN} = 1V_{P-P}$
CTL pin switch level	V_{TH}	2.2	—	3.3	V	—

○Not designed for radiation resistance.

●Measurement circuit

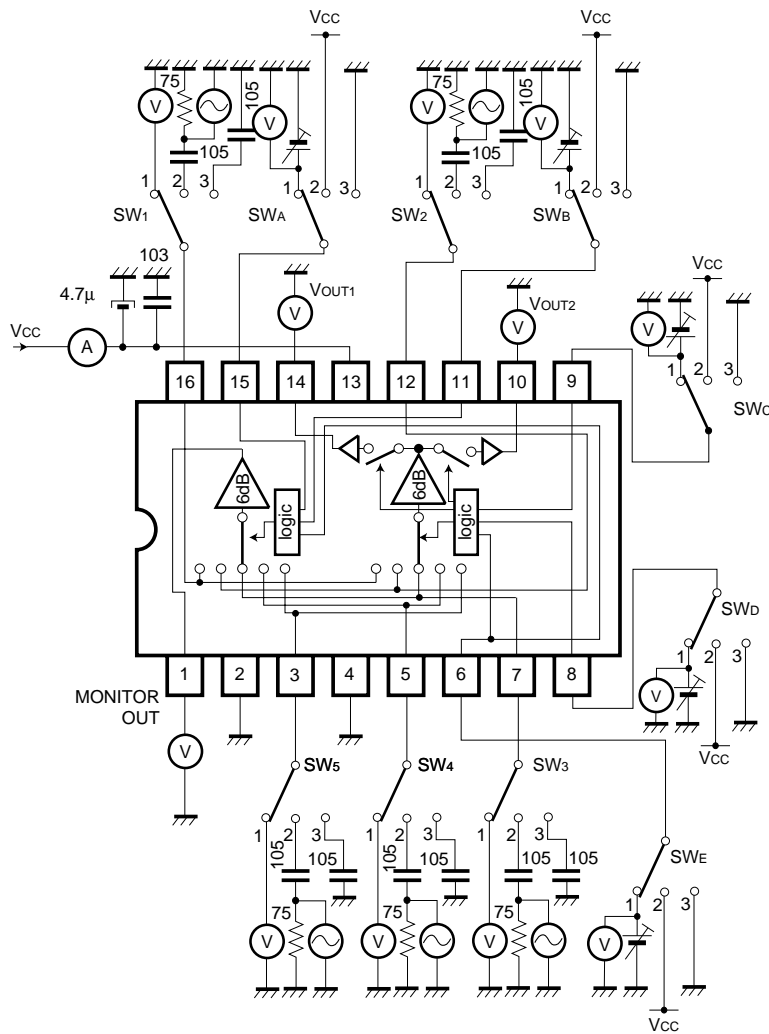

Fig.1

● Measurement conditions

Parameter	Symbol	Switch settings										Measurement method
		SW ₁	SW ₂	SW ₃	SW ₄	SW ₅	SW _A	SW _B	SW _C	SW _D	SW _E	
Current dissipation	I _{cc}	3	3	3	3	3	2	2	2	2	2	—
Monitor OUT maximum output level	V _{om} 1MON	2	3	3	3	3	3	3	*	*	*	Note 1
	V _{om} 2MON	3	2	↓	↓	↓	2	3	↓	↓	↓	
	V _{om} 3MON	↓	3	2	↓	↓	3	2	↓	↓	↓	
	V _{om} 4MON	↓	↓	3	2	↓	2	2	↓	↓	3	
	V _{om} 5MON	↓	↓	↓	3	2	2	2	↓	↓	2	
Monitor OUT voltage gain	G _v 1MON	2	3	3	3	3	3	3	*	*	*	Note 2
	G _v 2MON	3	2	↓	↓	↓	2	3	↓	↓	↓	
	G _v 3MON	↓	3	2	↓	↓	3	2	↓	↓	↓	
	G _v 4MON	↓	↓	3	2	↓	2	2	↓	↓	3	
	G _v 5MON	↓	↓	↓	3	2	2	2	↓	↓	2	
Monitor OUT interchannel crosstalk	C _T 1-2MON	2	3	3	3	3	2	3	*	*	*	Note 3
	C _T 1-3MON	↓	↓	↓	↓	↓	3	2	↓	↓	↓	
	C _T 1-4MON	↓	↓	↓	↓	↓	2	2	↓	↓	3	
	C _T 1-5MON	↓	↓	↓	↓	↓	2	2	↓	↓	2	
	C _T 2-1MON	3	2	3	3	3	3	3	*	*	*	
	C _T 2-3MON	↓	↓	↓	↓	↓	3	2	↓	↓	↓	
	C _T 2-4MON	↓	↓	↓	↓	↓	2	2	↓	↓	3	
	C _T 2-5MON	↓	↓	↓	↓	↓	2	2	↓	↓	2	
	C _T 3-1MON	3	3	2	3	3	3	3	*	*	*	
	C _T 3-2MON	↓	↓	↓	↓	↓	2	3	↓	↓	↓	
	C _T 3-4MON	↓	↓	↓	↓	↓	2	2	↓	↓	3	
	C _T 3-5MON	↓	↓	↓	↓	↓	2	2	↓	↓	2	
	C _T 4-1MON	3	3	3	2	3	3	3	*	*	*	
	C _T 4-2MON	↓	↓	↓	↓	↓	2	3	↓	↓	↓	
	C _T 4-3MON	↓	↓	↓	↓	↓	2	2	↓	↓	↓	
	C _T 4-5MON	↓	↓	↓	↓	↓	2	2	↓	↓	3	
	C _T 5-1MON	3	3	3	3	2	3	3	*	*	*	
	C _T 5-2MON	↓	↓	↓	↓	↓	2	3	↓	↓	↓	
	C _T 5-3MON	↓	↓	↓	↓	↓	2	2	↓	↓	↓	
	C _T 5-4MON	↓	↓	↓	↓	↓	2	2	↓	↓	2	
Monitor OUT frequency characteristic	G _f 1MON	2	3	3	3	3	3	3	*	*	*	Note 4
	G _f 2MON	3	2	↓	↓	↓	2	3	↓	↓	↓	
	G _f 3MON	↓	3	2	↓	↓	3	2	↓	↓	↓	
	G _f 4MON	↓	↓	3	2	↓	2	2	↓	↓	3	
	G _f 5MON	↓	↓	↓	3	2	2	2	↓	↓	2	
V _{OUT1} maximum output level	V _{om} 2OUT1	3	2	3	3	3	*	*	2	3	*	Note 1
	V _{om} 3OUT1	↓	3	2	↓	↓	↓	↓	3	2	↓	
	V _{om} 4OUT1	↓	↓	3	2	3	↓	↓	2	2	3	
	V _{om} 5OUT1	↓	↓	↓	3	2	↓	↓	2	2	2	

Parameter	Symbol	Switch settings										Measurement method
		SW ₁	SW ₂	SW ₃	SW ₄	SW ₅	SW _A	SW _B	SW _C	SW _D	SW _E	
V _{OUT1} voltage gain	G _V 2OUT1	3	2	3	3	3	*	*	2	3	*	Note 2
	G _V 3OUT1	↓	3	2	↓	↓	↓	↓	3	2	↓	
	G _V 4OUT1	↓	↓	3	2	3	↓	↓	2	2	3	
	G _V 5OUT1	↓	↓	↓	3	2	↓	↓	2	2	2	
V _{OUT1} interchannel crosstalk	C _{T1} -2OUT1	2	3	3	3	3	*	*	3	3	*	Note 3
	C _{T1} -3OUT1	↓	↓	↓	↓	↓	↓	↓	3	2	↓	
	C _{T1} -4OUT1	↓	↓	↓	↓	↓	↓	↓	2	2	3	
	C _{T1} -5OUT1	↓	↓	↓	↓	↓	↓	↓	2	2	2	
	C _{T2} -1OUT1	3	2	3	3	3	*	*	3	3	*	
	C _{T2} -3OUT1	↓	↓	↓	↓	↓	↓	↓	3	2	↓	
	C _{T2} -4OUT1	↓	↓	↓	↓	↓	↓	↓	2	2	3	
	C _{T2} -5OUT1	↓	↓	↓	↓	↓	↓	↓	2	2	2	
	C _{T3} -1OUT1	3	3	2	3	3	*	*	3	3	*	
	C _{T3} -2OUT1	↓	↓	↓	↓	↓	↓	↓	2	3	↓	
	C _{T3} -4OUT1	↓	↓	↓	↓	↓	↓	↓	2	2	3	
	C _{T3} -5OUT1	↓	↓	↓	↓	↓	↓	↓	2	2	2	
	C _{T4} -1OUT1	3	3	3	2	3	*	*	3	3	*	
	C _{T4} -2OUT1	↓	↓	↓	↓	↓	↓	↓	2	3	↓	
	C _{T4} -3OUT1	↓	↓	↓	↓	↓	↓	↓	3	2	↓	
	C _{T4} -5OUT1	↓	↓	↓	↓	↓	↓	↓	2	2	2	
	C _{T5} -1OUT1	3	3	3	3	2	*	*	3	3	*	
	C _{T5} -2OUT1	↓	↓	↓	↓	↓	↓	↓	2	3	↓	
	C _{T5} -3OUT1	↓	↓	↓	↓	↓	↓	↓	3	2	↓	
	C _{T5} -4OUT1	↓	↓	↓	↓	↓	↓	↓	2	2	3	
V _{OUT1} frequency characteristic	G _f 2OUT1	3	2	3	3	3	*	*	2	3	*	Note 4
	G _f 3OUT1	↓	3	2	↓	↓	↓	↓	3	2	↓	
	G _f 4OUT1	↓	↓	3	2	↓	↓	↓	2	2	3	
	G _f 5OUT1	↓	↓	↓	3	2	↓	↓	2	2	2	
V _{OUT2} maximum output level	V _{om} 1OUT2	2	3	3	3	3	*	*	3	3	*	Note 1
	V _{om} 3OUT2	3	2	↓	↓	↓	↓	↓	3	2	↓	
	V _{om} 4OUT2	↓	3	↓	2	↓	↓	↓	2	2	3	
	V _{om} 5OUT2	↓	↓	↓	3	2	↓	↓	2	2	2	
V _{OUT2} voltage gain	G _V 1OUT2	2	3	3	3	3	*	*	3	3	*	Note 2
	G _V 3OUT2	3	2	↓	↓	↓	↓	↓	3	2	↓	
	G _V 4OUT2	↓	3	↓	2	↓	↓	↓	2	2	3	
	G _V 5OUT2	↓	↓	↓	3	2	↓	↓	2	2	2	

Parameter	Symbol	Switch settings										Measurement method
		SW ₁	SW ₂	SW ₃	SW ₄	SW ₅	SW _A	SW _B	SW _C	SW _D	SW _E	
V _{OUT2} interchannel crosstalk	C _{T1} -2OUT2	2	3	3	3	3	*	*	2	3	*	Note 3
	C _{T1} -3OUT2	↓	↓	↓	↓	↓	↓	↓	3	2	↓	
	C _{T1} -4OUT2	↓	↓	↓	↓	↓	↓	↓	2	2	3	
	C _{T1} -5OUT2	↓	↓	↓	↓	↓	↓	↓	2	2	2	
	C _{T2} -1OUT2	3	2	3	3	3	*	*	3	3	*	
	C _{T2} -3OUT2	↓	↓	↓	↓	↓	↓	↓	3	2	↓	
	C _{T2} -4OUT2	↓	↓	↓	↓	↓	↓	↓	2	2	3	
	C _{T2} -5OUT2	↓	↓	↓	↓	↓	↓	↓	2	2	2	
	C _{T3} -1OUT2	3	3	2	3	3	*	*	3	3	*	
	C _{T3} -2OUT2	↓	↓	↓	↓	↓	↓	↓	2	3	↓	
	C _{T3} -4OUT2	↓	↓	↓	↓	↓	↓	↓	2	2	3	
	C _{T3} -5OUT2	↓	↓	↓	↓	↓	↓	↓	2	2	2	
	C _{T4} -1OUT2	3	3	3	2	3	*	*	3	3	*	
	C _{T4} -2OUT2	↓	↓	↓	↓	↓	↓	↓	2	3	↓	
	C _{T4} -3OUT2	↓	↓	↓	↓	↓	↓	↓	3	2	↓	
	C _{T4} -5OUT2	↓	↓	↓	↓	↓	↓	↓	2	2	2	
	C _{T5} -1OUT2	3	3	3	3	2	*	*	3	3	*	
	C _{T5} -2OUT2	↓	↓	↓	↓	↓	↓	↓	2	3	↓	
	C _{T5} -3OUT2	↓	↓	↓	↓	↓	↓	↓	3	2	↓	
	C _{T5} -4OUT2	↓	↓	↓	↓	↓	↓	↓	2	2	3	
V _{OUT2} frequency characteristic	G _f 1OUT1	2	3	3	3	3	*	*	3	3	*	Note 4
	G _f 3OUT1	3	3	2	↓	↓	↓	↓	3	2	↓	
	G _f 4OUT1	↓	↓	3	2	↓	↓	↓	2	2	3	
	G _f 5OUT1	↓	↓	↓	3	2	↓	↓	2	2	2	
Mute level	CTM V _{OUT1}	2	3	3	3	3	*	*	3	3	*	Note 5
	CTM V _{OUT2}	↓	↓	↓	↓	↓	↓	↓	2	↓	↓	
CTL switching level	V _{TH} A	2	3	3	3	3	1	3	*	*	*	Note 6
	V _{TH} B	3	↓	2	↓	↓	3	1	↓	↓	↓	
	V _{TH} C	2	↓	3	↓	↓	*	*	1	3	↓	
	V _{TH} D	3	↓	2	↓	↓	↓	↓	3	1	↓	
	V _{TH} E	↓	↓	3	2	↓	2	2	*	*	1	

Note 1: Connect a distortion meter to the output, and input a f = 1kHz sine wave. Adjust the input level until the output distortion is 0.5%.

This output voltage at this time is the maximum output level V_{om} (V_{P-P}).

Note 2: Input a 1V_{P-P}, 1MHz sine wave. The voltage gain (in dB) is given by G_v = 20 log (V_{OUT} / V_{IN}).

Note 3: Input a 1V_{P-P}, 4.43MHz sine wave. The interchannel crosstalk (in dB) is given by C_T = 20 log (V_{OUT} / V_{IN}) + 6.

Note 4: Input 1V_{P-P}, 1MHz and 10MHz sine waves. The frequency characteristic (in dB) is given by G_f = 20 log (V_{OUT} (f = 10MHz) / V_{OUT} (f = 1MHz)).

Note 5: Input a 1V_{P-P}, 4.43MHz sine wave. The mute level is given by CTM = 20 log (V_{OUT} / V_{IN}) + 6 (dB).

Note 6: Input a 1V_{P-P}, 1MHz sine wave. Reduce the CTL pin voltage from V_{CC}.

The CTL pin switching level (V_{TH}) is the CTL pin voltage at which the V_{OUT} level drops below 10mV_{P-P}.

●Application example

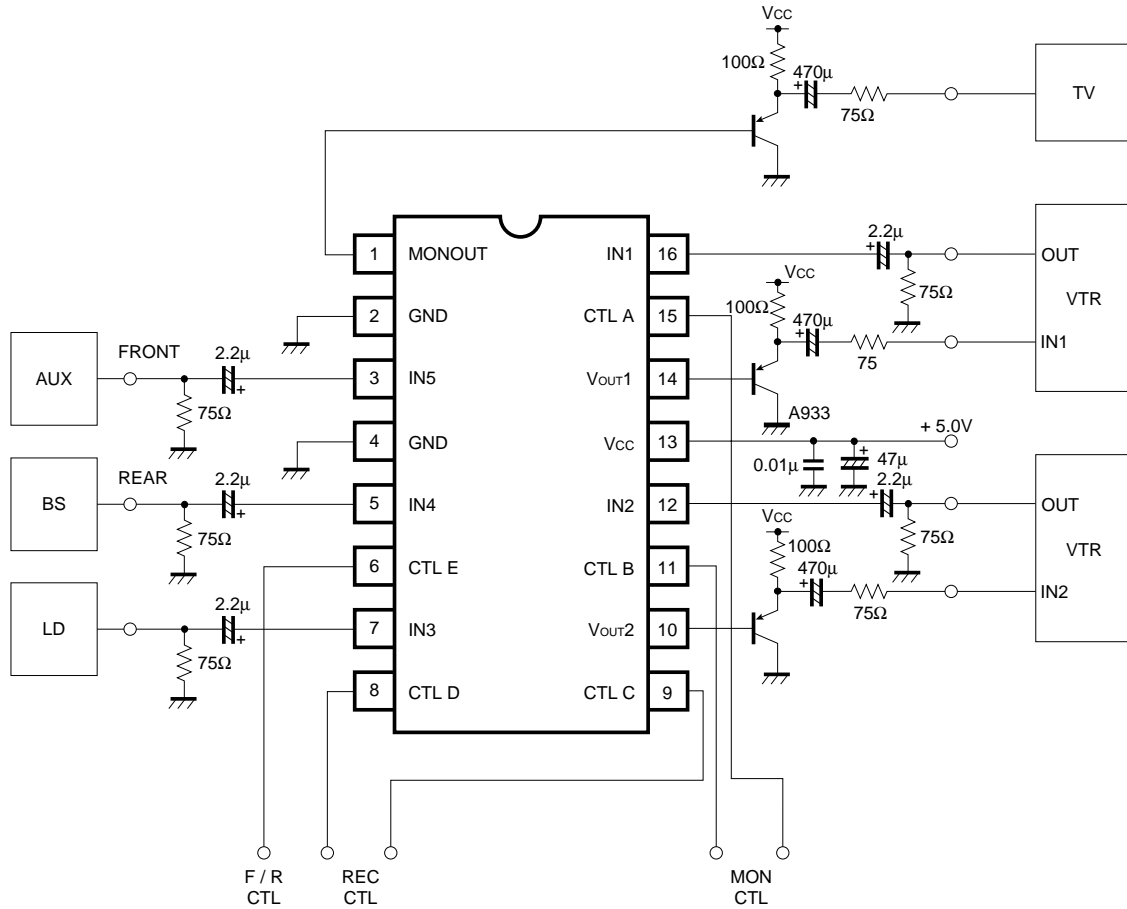

Fig.2

●External dimensions (Units: mm)

