

# DS34RT5110

## DVI, HDMI Retimer with Input Equalization and Output De-Emphasis

### General Description

The DS34RT5110 is a 10.2 Gbps (3 x 3.4 Gbps) high performance re-clocking device that supports 3 Transition Minimized Differential Signaling (TMDS®) data channels and a single clock channel over DVI™ v1.0, and HDMI™ v1.3a data rates up to 3.4 Gbps for each data channel. The device incorporates a configurable receive equalizer, a clock and data recovery (CDR) circuit and a de-emphasis driver on each data channel. The clock channel feeds a high-performance phase-locked loop (PLL) that regenerates a low jitter output clock for data recovery.

The DS34RT5110 equalizes and retimes greater than 25 meters 28 AWG of HDMI cable for 1080p resolution with 12 bit deep color depth (2.25 Gbps), to a low jitter version of the clock and data signal outputs, reducing both deterministic and random jitter. Several devices can be cascaded for long links without degrading signal fidelity. Obtaining total jitter is 0.09 UI or less over the supported data rates. This low level of output jitter provides system designers with extra margin and flexibility when working with stringent timing budgets.

The transmitter supports configurable transmit de-emphasis so the output can be optimized for driving additional lengths of cables or FR4 traces.

### Features

- Optimized for HDMI/DVI repeater applications
- TMDS compatible inputs with configurable receive equalization supporting data rates up to 3.4 Gbps
- TMDS compatible outputs with configurable transmit de-emphasis
- Dedicated CDR on each data channel reduces jitter transfer, enabling multiple devices to be cascaded without impairing signal fidelity
- Capable of multi-hop extension of HDMI/DVI applications at data rates between 250 Mbps and 3.4 Gbps
- Resistor adjustable differential output voltage for AC coupled Cat5e and Cat6 extension applications
- 2 equalizer settings for a wide range of cable reaches at different data rates
- Total Output Jitter of 0.09 UI at 2.25 Gbps
- Total Output Jitter of 0.10 UI at 3.4 Gbps
- DVI 1.0 and HDMI v1.3a compatible TMDS source and sink interface
- 7 mm x 7 mm 48 pin LLP package
- >8 kV HBM ESD protection
- 0 °C to +70 °C operating temperature

### Applications

- Repeater Applications
  - Digital Routers
  - HDMI / DVI Extender Multi-hops
- Source Applications
  - Video Cards
  - Blu-ray DVD Players
  - Game Consoles
- Sink Applications
  - High Definition Displays
  - Projectors

### Application Diagram

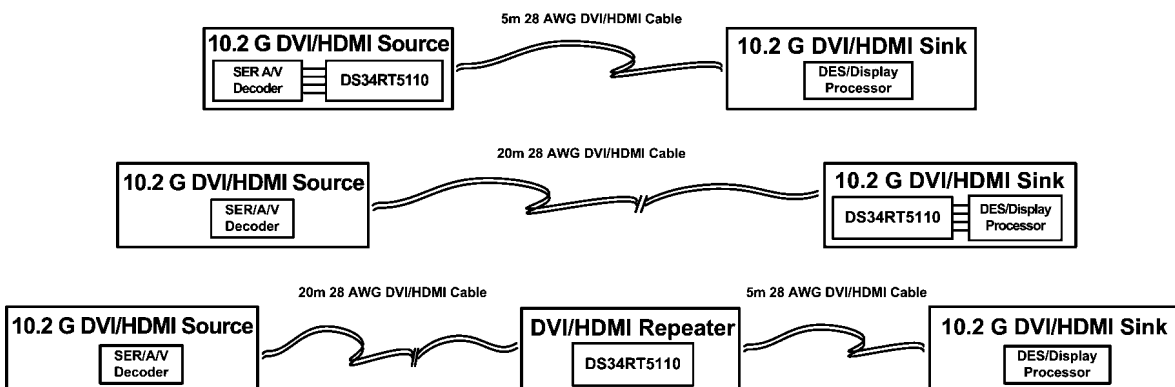

30087353

## Pin Descriptions

Pin Name	Pin Number	I/O, Type	Description
<b>High Speed Differential I/O</b>			
C_IN-	1	I, CML	Inverting and non-inverting TMDS Clock inputs to the equalizer. An on-chip 50 $\Omega$ terminating resistor connects C_IN+ to V <sub>DD</sub> and C_IN- to V <sub>DD</sub> .
C_IN+	2		
D_IN0-	4	I, CML	Inverting and non-inverting TMDS Data inputs to the equalizer. An on-chip 50 $\Omega$ terminating resistor connects D_IN0+ to V <sub>DD</sub> and D_IN0- to V <sub>DD</sub> .
D_IN0+	5		
D_IN1-	8	I, CML	Inverting and non-inverting TMDS Data inputs to the equalizer. An on-chip 50 $\Omega$ terminating resistor connects D_IN1+ to V <sub>DD</sub> and D_IN1- to V <sub>DD</sub> .
D_IN1+	9		
D_IN2-	11	I, CML	Inverting and non-inverting TMDS Data inputs to the equalizer. An on-chip 50 $\Omega$ terminating resistor connects D_IN2+ to V <sub>DD</sub> and D_IN2- to V <sub>DD</sub> .
D_IN2+	12		
C_OUT-	36	O, CML	Inverting and non-inverting TMDS outputs from the equalizer. Open collector.
C_OUT+	35		
D_OUT0-	33	O, CML	Inverting and non-inverting TMDS outputs from the equalizer. Open collector.
D_OUT0+	32		
D_OUT1-	29	O, CML	Inverting and non-inverting TMDS outputs from the equalizer. Open collector.
D_OUT1+	28		
D_OUT2-	26	O, CML	Inverting and non-inverting TMDS outputs from the equalizer. Open collector.
D_OUT2+	25		
<b>Equalization Control</b>			
EQ2	37	I, LVCMOS	EQ2, EQ1 and EQ0 select the equalizer boost level for EQ channels. Internally pulled LOW as default. See <a href="#">Table 1</a> .
EQ1	38		
EQ0	39		
<b>De-Emphasis Control</b>			
DE1	42	I, LVCMOS	DE1, DE0 select the DE-emphasis level for output drivers. Internally pulled low as default. Refer to <a href="#">Table 2</a> .
DE0	43		
<b>Device Control</b>			
BYPASS	47	I, LVCMOS	Reclocker enable control. Internally pulled low as default. H = Reclock and De-Emphasis function is bypassed. L = Normal operation.
EN	44	I, LVCMOS	Enable Output Drivers. Internally pulled HIGH as default. H = normal operation (enabled). L = standby mode.
MODE	21	I, LVCMOS	Clock channel mode control. Internally pulled LOW as default. H = Clock channel is bypassed. L = Normal operation.
SD	45	O, LVCMOS	Signal Detect Output pin. H = signal detected on all channels. L = no signal detected on one or more channels.
LOCK	14	O, LVCMOS	Lock Indicator Output pin. H = PLL is locked. L = PLL is not locked.
VOD_CRL	48	I, Analog	VOD control pin. Refer to <a href="#">Table 3</a> . See <i>Functional Description</i> . External resistance = 24 k $\Omega$ to GND, Output DC Coupled Application. External resistance = 12 k $\Omega$ to GND, Output AC Coupled Application.
LFp	40	I, Analog	Loop filter capacitor pins. See <i>Functional Description</i> .
LFn	41		

Pin Name	Pin Number	I/O, Type	Description
<b>Power</b>			
V <sub>DD</sub>	3, 6, 7, 10, 13, 15, 46	Power	V <sub>DD</sub> = 3.3 V ±5%. V <sub>DD</sub> pins should be tied to the V <sub>DD</sub> plane through a low inductance path. A 0.1 μF bypass capacitor should be connected between each V <sub>DD</sub> pin to the GND planes. See Power Supply Bypassing for additional details.
GND	22, 24, 27, 30, 31, 34	GND	Ground reference. GND should be tied to a solid ground plane through a low impedance path.
Exposed DAP	DAP	GND	Ground reference. The exposed pad at the center of the package must be connected to the ground plane.
<b>Other</b>			
Reserv	16, 17, 18, 19, 20, 23		Reserved. Do not connect. Leave open.

Note: I = Input, O = Output, IO = Input/Output,

## Connection Diagram

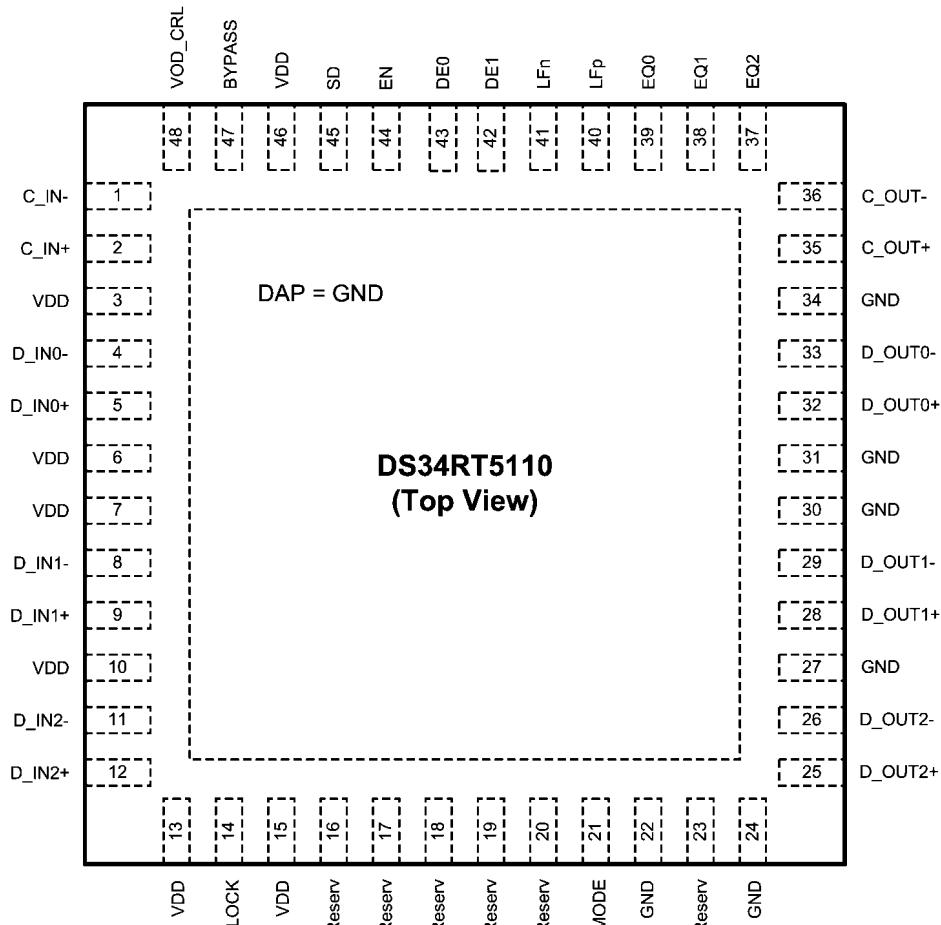

30087352

TOP VIEW — Not to Scale

### Ordering Information

NSID	Package	Tape & Reel QTY	Package Number
DS34RT5110SQE	48 Lead LLP	250	SQA48A
DS34RT5110SQ	48 Lead LLP	1,000	SQA48A
DS34RT5110SQX	48 Lead LLP	2,500	SQA48A

## Absolute Maximum Ratings *(Note 1)*

If Military/Aerospace specified devices are required, please contact the National Semiconductor Sales Office/Distributors for availability and specifications.

Supply Voltage ( $V_{DD}$ )	-0.5V to 4.0 V
LVC MOS Input Voltage	-0.5V to ( $V_{DD} + 0.5$ ) V
LVC MOS Output Voltage	-0.5V to ( $V_{DD} + 0.5$ ) V
CML Input/Output Voltage	-0.5V to ( $V_{DD} + 0.5$ ) V
Junction Temperature	+125°C
Storage Temperature	-65°C to +150°C
Lead Temp. (Soldering, 5 sec.)	+260°C

ESD Rating

HBM, 1.5 k $\Omega$ , 100 pF

&gt;8 kV

Thermal Resistance

 $\theta_{JA}$ , No Airflow

33°C/W

## Recommended Operating Conditions *(Note 3, Note 4)*

	Min	Typ	Max	Units
Supply Voltage ( $V_{DD}$ to GND)	3.135	3.3	3.465	V
Supply Noise Tolerance (100 Hz to 50 MHz)		100		mVp-p
Ambient Temperature	0	25	+70	°C

## Electrical Characteristics

Over recommended operating supply and temperature ranges unless otherwise specified. All parameters are guaranteed by test, statistical analysis, or design unless otherwise specified. *(Note 3)*

Symbol	Parameter	Condition	Min	Typ	Max	Units
<b>Power</b>						
P	Power Supply Consumption	EN = H, Device Enabled PRBS15 pattern, fCLK=340 MHz RT= 50 $\Omega$ to AV <sub>CC</sub> ; <i>Figure 2</i>		1100	1250	mW
		EN = L, Standby Mode PRBS15 pattern, fCLK=340 MHz RT= 50 $\Omega$ to AV <sub>CC</sub> ; <i>Figure 2</i>		850	1000	mW
<b>LVC MOS / LVTTL DC Specifications</b>						
VIH	High Level Input Voltage		2		$V_{DD}$	V
VIL	Low Level Input Voltage		GND		0.8	V
VOH	High Level Output Voltage	IOH = -3 mA	2.4			V
VOL	Low Level Output Voltage	IOL = 3 mA			0.4	V
IIH	Input High Current	VIN = $V_{DD}$ , EQ2, EQ1, EQ0, DE1, DE0, BYPASS, MODE pins (pull down)			60	$\mu$ A
		VIN = $V_{DD}$ , EN pin (pull up)	-15			$\mu$ A
IIL	Input Low Current	VIN = 0 V, EQ2, EQ1, EQ0, DE1, DE0, BYPASS, MODE pins (pull down)			15	$\mu$ A
		VIN = 0 V, EN pin (pull up)	-20			$\mu$ A
<b>Signal Detect</b>						
SDH	Signal Detect High	Default Input signal level to assert SD pin		80		mVp-p
SDL	Signal Detect Low	Default Input signal level to deassert SD		20		mVp-p

Symbol	Parameter	Condition	Min	Typ	Max	Unit
<b>CML Inputs</b>						
VTX	Input Voltage Swing (Launch Amplitude)	Measured differentially at TPA, Figure 1, note 4	800	1000	1560	mVp-p
VICMDC	Input Common-Mode Voltage	DC-Coupled requirement Measured at TPB, VINmin = 800mV, VINmax = 1200mV, <a href="#">Figure 1</a>	$V_{DD}-0.3$		$V_{DD}-0.2$	V
VIN	Input Voltage Sensitivity	Measured differentially at TPB, <a href="#">Figure 1</a> 3.4 Gbps, Clock Pattern	150		1560	mVp-p
RIN	Input resistance	IN+ to $V_{DD}$ and IN- to $V_{DD}$	40	50	60	Ohms
RLI	Differential output return loss	100 MHz – 1125 MHz		10		dB
<b>CML Outputs</b>						
VOFF	Standby Output Voltage	Measured DC outputs at TPC, RT = 50Ω when DUT $V_{DD}$ is off with OUT+ and OUT- terminated by RT= 50Ω to $AV_{CC}$ , <a href="#">Figure 2</a>	$AV_{CC} - 10$		$AV_{CC} + 10$	mV
VO	Differential Output voltage swing	External resistor = 24 kΩ at VOD_CRL pin. Measured differentially with OUT+ and OUT- terminated by RT=50Ω to $AV_{CC}$ , <a href="#">Figure 2</a>	800		1200	mVp-p
VOCM	Output common-mode Voltage	Measured single-ended, >1.65 Gbps, Figures 2, 3	$AV_{CC} - 0.35$		$AV_{CC} - 0.20$	V
tR, tF	Transition time	20% to 80% of differential output voltage, measured within 1" from output pins, <a href="#">Figure 3</a>		80		ps
tCCSK	Inter Pair Data Channel-to-Channel Skew (all 3 data channels)	Difference in 50% crossing between channels 3.4 Gbps, Clock Pattern ( <a href="#">Note 4</a> )		2	3	ps
tPPSK	Inter Pair Data Channels Part-toPart Skew	Difference in 50% crossing between channels of any two devices 3.4 Gbps, Clock Pattern		50		ps
tDD	Data Channels Latency	3.4 Gbps, Clock Pattern, <a href="#">Figure 4</a>		520		ps
tCD	Clock Channel Latency	3.4 Gbps, Clock Pattern, <a href="#">Figure 4</a>		600		ps
<b>LVC MOS Outputs</b>						
tSL	SD to LOCK time	<a href="#">Figure 4</a>		10		ms
<b>Bit Rate</b>						
fCLK	Clock Frequency	Clock Path ( <a href="#">Note 4</a> )	25		340	MHz
bR	Bit Rate	Data Paths ( <a href="#">Note 4</a> )	0.25		3.4	Gbps

Symbol	Parameter	Condition	Min	Typ	Max	Unit
<b>Data Channel Random Jitter</b>						
RJ	Random Jitter	( <a href="#">Note 4</a> , <a href="#">Note 5</a> , <a href="#">Note 6</a> )		3		psrms
<b>Data Channel CDR Jitter Generation</b>						
TROJ1	Total Output Jitter 0.25 Gbps	Data Paths, measured at TPC PRBS7, EQ [2:0] = 000 <a href="#">Figure 1</a> , ( <a href="#">Note 4</a> , <a href="#">Note 5</a> , <a href="#">Note 6</a> )		0.03	0.05	Ulp-p
TROJ2	Total Output Jitter 1.65 Gbps	Data Paths, measured at TPC PRBS7, EQ [2:0] = 000 <a href="#">Figure 1</a> , ( <a href="#">Note 4</a> , <a href="#">Note 5</a> , <a href="#">Note 6</a> )		0.08	0.14	Ulp-p
TROJ3	Total Output Jitter 2.25 Gbps	Data Paths, measured at TPC PRBS7, EQ [2:0] = 000 <a href="#">Figure 1</a> , ( <a href="#">Note 4</a> , <a href="#">Note 5</a> , <a href="#">Note 6</a> )		0.09	0.16	Ulp-p
TROJ4	Total Output Jitter 3.4 Gbps	Data Paths, measured at TPC PRBS7, EQ [2:0] = 000 <a href="#">Figure 1</a> , ( <a href="#">Note 4</a> , <a href="#">Note 5</a> , <a href="#">Note 6</a> )		0.10	0.17	Ulp-p
BWLOOP	CDR Loop Bandwidth	0.25 Gbps data rate		0.25		MHz
		1.65 Gbps data rate		1.65		MHz
		2.25 Gbps data rate		2.25		MHz
		3.4 Gbps data rate		2.25		MHz
<b>Clock Channel PLL Jitter Generation</b>						
TROJ5	Total Output Jitter 25 MHz	Clock Path, measured at TPC <a href="#">Figure 1</a> ( <a href="#">Note 4</a> , <a href="#">Note 5</a> , <a href="#">Note 6</a> )		0.03	0.045	Ulp-p
TROJ6	Total Output Jitter 165 MHz	Clock Path, measured at TPC <a href="#">Figure 1</a> ( <a href="#">Note 4</a> , <a href="#">Note 5</a> , <a href="#">Note 6</a> )		0.07	0.13	Ulp-p
TROJ7	Total Output Jitter 225 MHz	Clock Path, measured at TPC <a href="#">Figure 1</a> ( <a href="#">Note 4</a> , <a href="#">Note 5</a> , <a href="#">Note 6</a> )		0.08	0.135	Ulp-p
TROJ8	Total Output Jitter 340 MHz	Clock Path, measured at TPC <a href="#">Figure 1</a> ( <a href="#">Note 4</a> , <a href="#">Note 5</a> , <a href="#">Note 6</a> )		0.09	0.14	Ulp-p

**Note 1:** "Absolute Maximum Ratings" are the ratings beyond which the safety of the device cannot be guaranteed. They are not meant to imply that the device should be operated at these limits.

**Note 2:** Allowed supply noise (mVp-p sine wave) at typical condition.

**Note 3:** Typical parameters are measured at  $V_{DD} = 3.3\text{ V}$ ,  $T_A = 25\text{ }^\circ\text{C}$ . They are for reference purposes, and are not production-tested.

**Note 4:** Parameter is guaranteed by statistical analysis and/or design.

**Note 5:** Deterministic jitter is measured at the differential outputs (TPC of [Figure 1](#)), minus the deterministic jitter before the test channel (TPA of [Figure 1](#)). Random jitter is removed through the use of averaging or similar means.

**Note 6:** Total Jitter is defined as peak-to-peak deterministic jitter from + 12 times random jitter (ps).

**Note 7:** Random jitter contributed by the equalizer is defined as  $\text{sq rt}(J_{\text{OUT}}^2 - J_{\text{IN}}^2)$ .  $J_{\text{OUT}}$  is the random jitter at equalizer outputs in ps-rms, see TPC of [Figure 1](#);  $J_{\text{IN}}$  is the random jitter at the input of the equalizer in ps-rms, see TPA of [Figure 1](#).

## Setup and Timing Diagrams

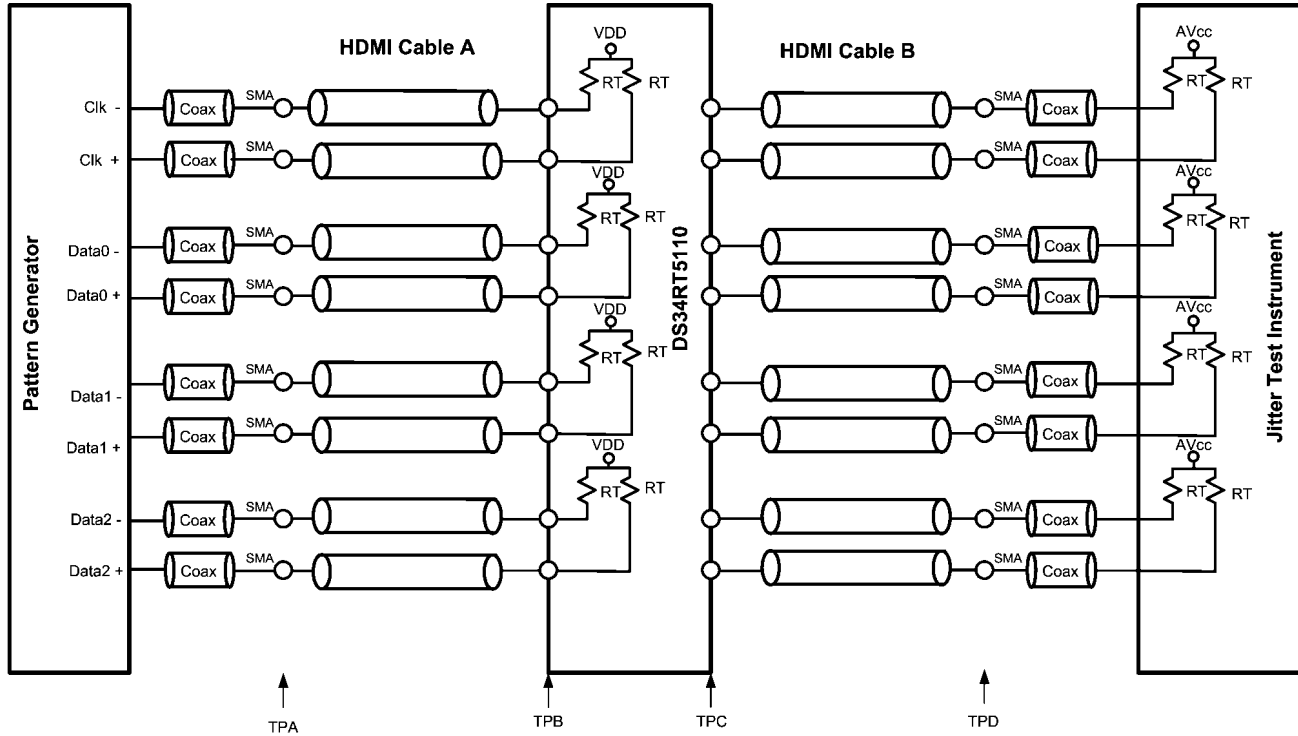

30087310

FIGURE 1. Test Setup Diagram

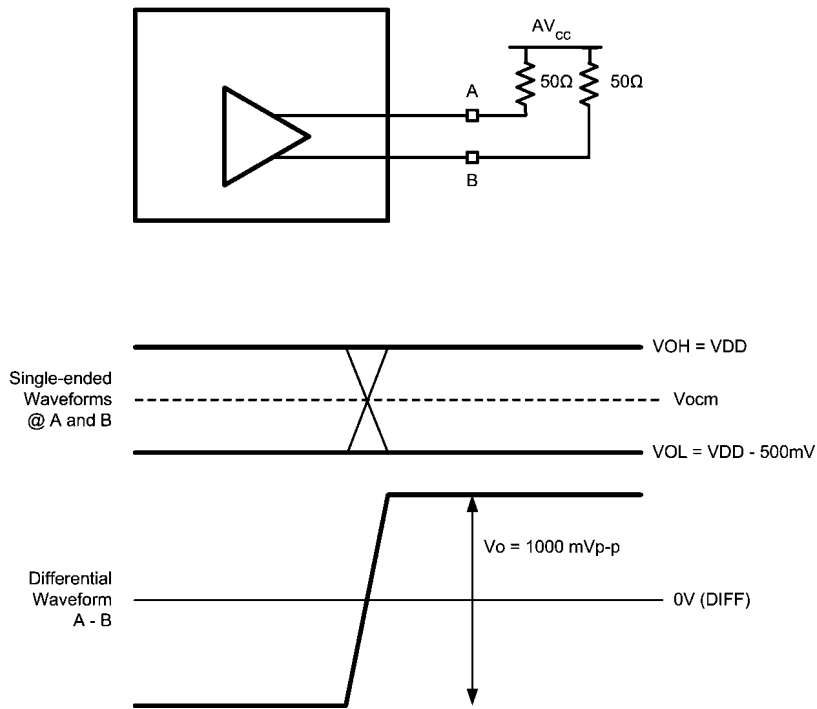

30087312

FIGURE 2. CML Output Swings at A/B ( $V_{OD\_CRL} = 24 \text{ k}\Omega$ )

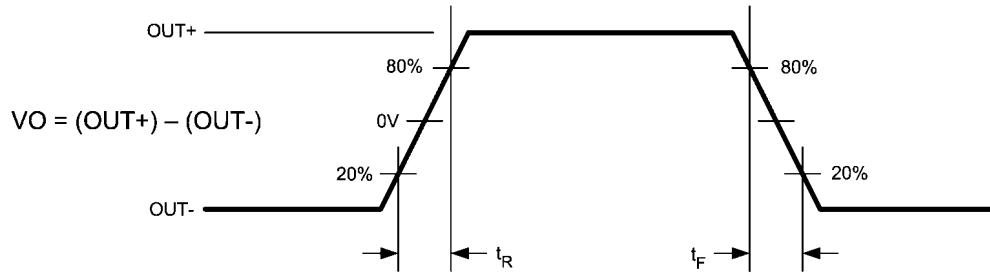

30087311

FIGURE 3. CML Output Transition Times

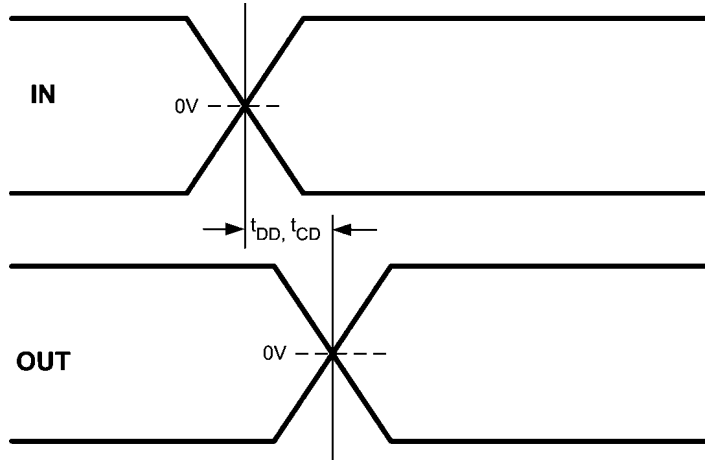

30087313

FIGURE 4. CML Latency Delay Time

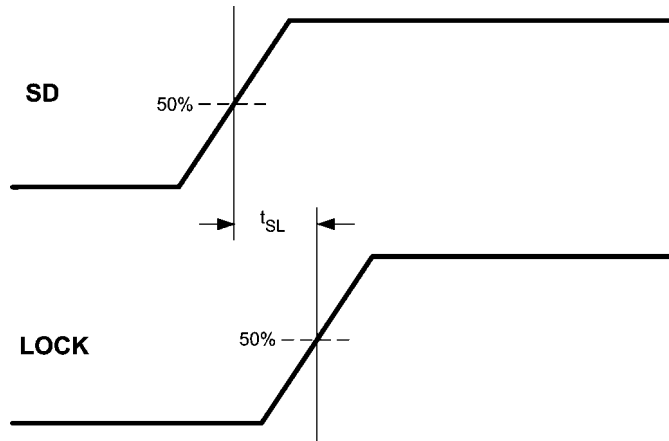

30087314

FIGURE 5. SD - LOCK Delay Time



## Functional Description

The DS34RT5110 DVI, HDMI Retimer with Input Equalization and Output De-Emphasis consists of three data channels and

a clock channel. Each data channel consists of a TMD5 compatible receiver with a power efficient equalizer, a dedicated clock-data recovery (CDR) unit, and a TMD5 compatible transmitter.

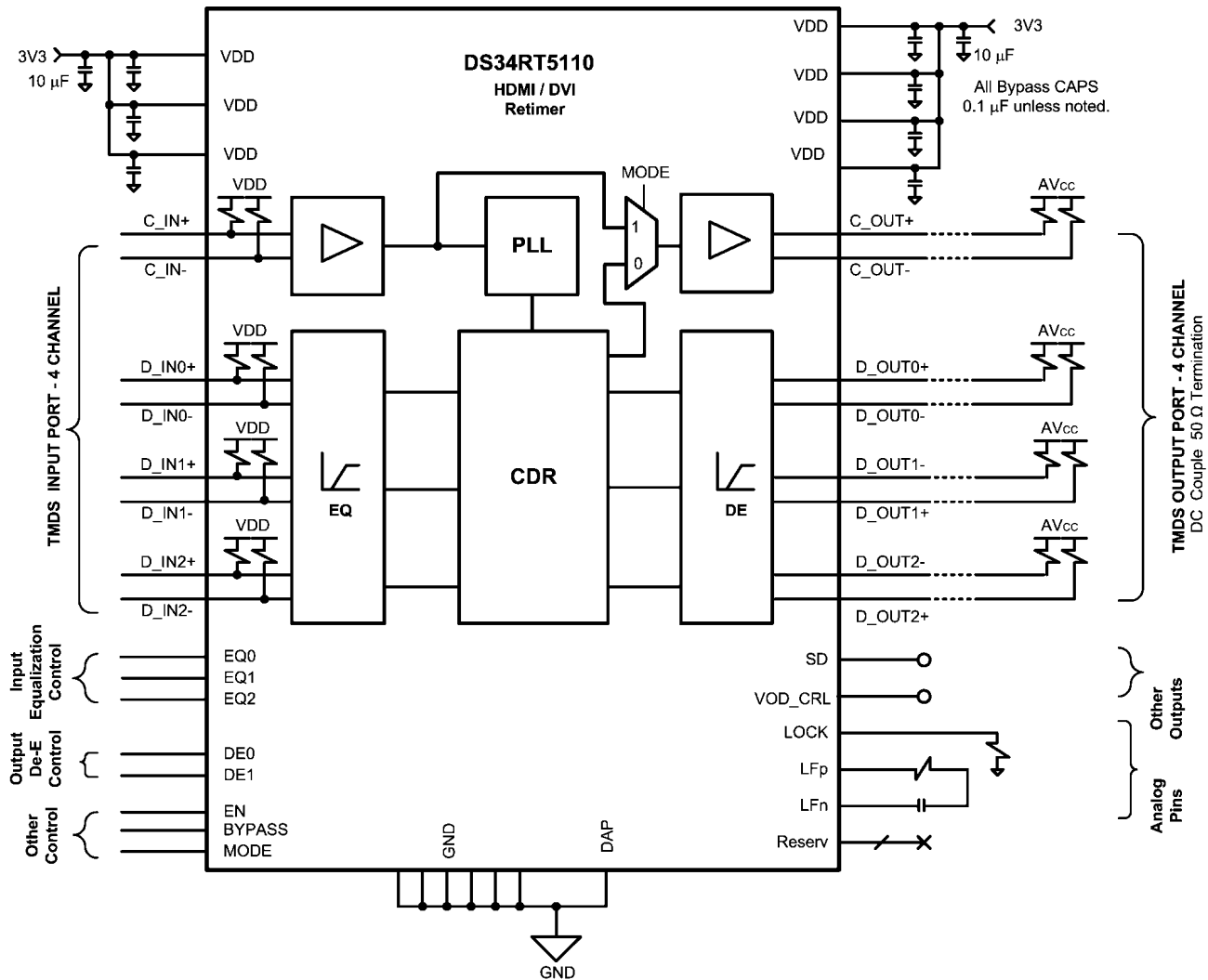

30087315

FIGURE 6. Block Diagram

### PHASE-LOCKED-LOCKED LOOP (PLL)

The clock channel has a high-performance PLL that creates a low jitter sampling clock for the clock and data recovery units in the data channels. An external loop filter, composed of 2.2 nF (+ 5% tolerance) capacitor and a 3.3 k $\Omega$  (+ 5% tolerance) resistor in series, are required between the LFP and the LFN pins.

### CLOCK-DATA RECOVERY UNIT (CDR)

Each TMD5 data channel has a CDR that operates independently from other TMD5 data channels. Each CDR aligns the sampling clock edges by digitally interpolating the clock from PLL of the TMD5 clock channel. The device is designed to connect to DVI/HDMI compatible transmitter and receiver at any data rate between 250 Mbps to 3.4 Gbps. The loop bandwidth of the CDR is approximately  $\text{baud\_rate}/1000$ , i.e. 2.25 MHz for 2.25 Gbps data.

### INPUT EQUALIZATION

The input data channel equalizers support eight programmable levels of equalization boost [Table 1](#) by the EQ pins (EQ [2:0]). The range of boost settings provided enables the DS34RT5110 to address a wide range of transmission line path loss scenarios, enabling support for a variety of data rates and formats. See *Applications Information for recommended EQ settings*.

### OUTPUT DE-EMPHASIS

De-emphasis is the conditioning function for use in compensating against backplane and cable transmission loss. The DS34RT5110 provides four steps of de-emphasis ranging from 0, 3, 6 and 9 dB, user-selectable dependent on the loss profile of output channels. [Table 2](#) shows the De-emphasis control with default  $VO = 1000$  mVp-p, and [Figure 7](#) shows a driver de-emphasis waveform.

**OUTPUT VO CONTROL**

Output differential voltage (VO) is controlled through VOD\_CRL pin ties an external resistor to the ground as shown

in *Table 3*. Users should restrict the external resistor values used to be 12 kΩ to 24 kΩ. +5% tolerance is recommended.

**TABLE 1. Equalization Control**

INPUTS			RESULT
EQ2	EQ1	EQ0	Equalization in dB (1.7 GHz)
0	0	0	0 (default)
0	0	1	10
0	1	0	16
0	1	1	19
1	0	0	23
1	0	1	25
1	1	0	26
1	1	1	27

**TABLE 2. De-Emphasis Control**

INPUTS		RESULT	
DE1	DE0	VO De-Emphasis level in mVp-p (VODE w/VOD_CRL = 24 kΩ)	VO De-Emphasis in dB
0	0	1000 (default)	0 (default)
0	1	710	-3
1	0	500	-6
1	1	355	-9

**TABLE 3. VO Control**

External Resistor Value (VOD_CRL pin)	Applications	VO Level (mVp-p)
24 kΩ	DC Coupled	1000
12 kΩ	AC Coupled	1000

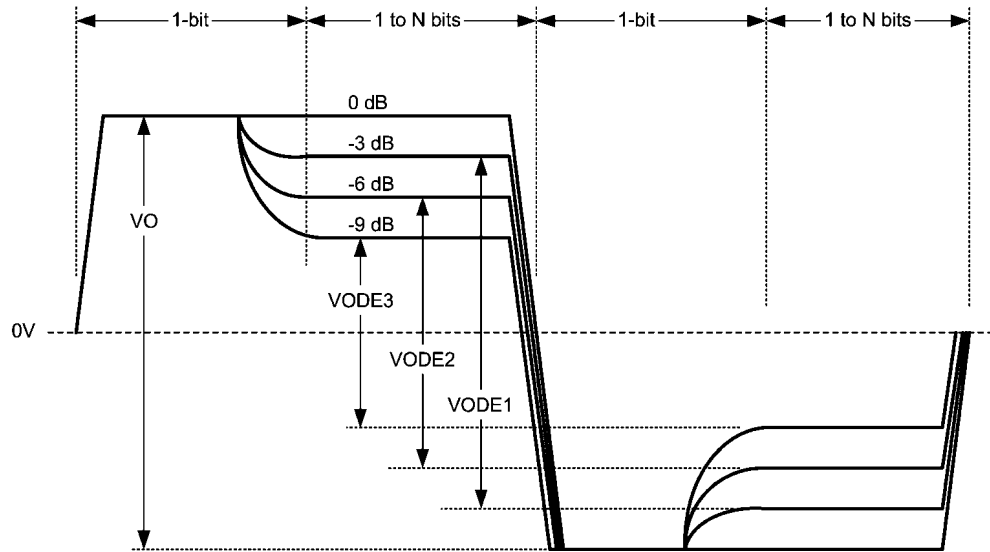

**FIGURE 7. Output De-Emphasis Differential Waveform (showing all de-emphasis steps)**

### RETIMING AND DE-EMPHASIS BYPASS

The retiming and De-emphasis BYPASS pin provides the flexibility to configure the device to an equalizer only mode. The device is in normal operation, when holding a LOW state on the BYPASS pin. The retiming and De-emphasis features are disabled, when a HIGH state is applied.

### CLOCK CHANNEL MODE CONTROL

During the normal operation mode, the clock channel signal is regenerated by the PLL and the CDR. Holding a LOW state (default) on the MODE pin places the DS34RT5110 in this normal operation mode. A HIGH state on the MODE pin bypasses the clock channel. This clock channel mode feature enables the multi-hop applications. (*Refer to Application Information – Multiple Hop Application for detailed information*)

### DEVICE STATE AND ENABLE CONTROL

The DS34RT5110 has an Enable feature which provides the ability to control device power consumption. This feature can be controlled via the Enable Pin (EN Pin). If Enable is activated, the data channels and clock channel are placed in the ACTIVE state and all device blocks function as described. The DS34RT5110 can also be placed in STANDBY mode to save power. In this mode, the output drivers of the device are disabled. The CML outputs are in the HIGH (AVCC) state. All LVCMOS outputs are in the HiZ state.

### LOCK DETECT

When the PLL of the DS34RT5110 is locked, and the generated reference phases are successfully interpolated by the

CDR, this status is indicated by a logic HIGH on the LOCK pin. The LOCK pin may be connected to the Enable (EN) pin input to disable the data channels and clock channel when no data signal is being received.

### SIGNAL DETECT

The DS34RT5110 features a signal detect circuit on all channels. The status of the input signals can be determined by the state of the SD pin. A logic HIGH indicates the presence of signals that have exceeded a specified maximum threshold value (called SD\_ON) on all channels. A logic LOW means that the signals have fallen below a minimum threshold value (called SD\_OFF) on one or more channels.

### AUTOMATIC ENABLE FEATURE

During normal operation (i.e. BYPASS pin is LOW), the DS34RT5110 can be configured to automatically enter STANDBY mode, if the PLL of the DS34RT5110 is not locked. The STANDBY mode can be implemented by connecting the LOCK DETECT (LOCK) pin to the external (LVCMOS) Enable (EN) pin. If the LOCK pin is connected to the EN pin, a logic HIGH on the LOCK pin will enable the device; thus the DS34RT5110 will automatically enter the ACTIVE state. If the PLL is unlocked, then the LOCK pin will be asserted LOW, causing the aforementioned blocks to be placed in the STANDBY state.

## Application Information

The DS34RT5110 is a DVI/HDMI video signal reconditioning device. The device conforms to DVI v1.0 and HDMI v1.3a standards supporting up to 10.2 Gbps total throughput TMDS data for 1080p with 48 bit deep color depth.

### TYPICAL APPLICATION

In general, the DS34RT5110 in the default mode (MODE = L) is used as a DVI/HDMI source device, sink device, or a re-

peater device, see [Figure 8](#). As the source device, the output de-emphasis setting should be configured based on the driving cable length. When used as the sink device, the levels of the equalization boost of the input data channels should be optimized based on the receiving cable length. The DS34RT5110 can also be used as a repeater in an external extender box with the equalization and de-emphasis level settings optimized to provide the maximum cable reach.

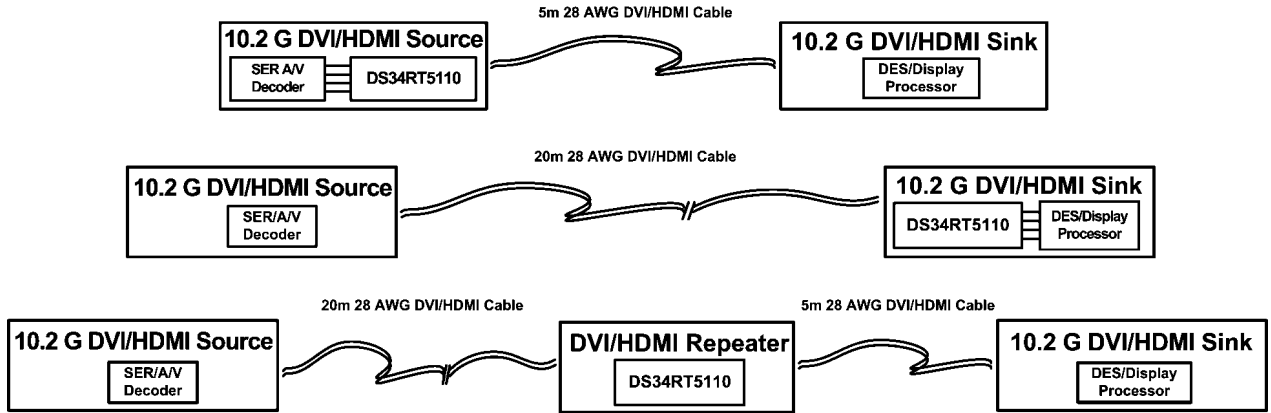

30087353

FIGURE 8. Typical Application Diagram

### MULTIPLE HOP APPLICATION

For DVI/HDMI home theater and professional studio systems with extensive lengths of cable, multi-hops with 2 or more cascaded DS34RT5110 devices can be implemented as shown in [Figure 9](#). In order to reach the maximum cable length, the levels of the equalization and de-emphasis should be optimized for each individual hop. The MODE pin(s) of the

device at the first hop (using two hop application), or at the first and the second hops (using three hop application shown in [Figure 9](#)) is recommended to be set HIGH to minimize the jitter accumulation in multiple hops. The MODE pin of the device for the final hop should be set to a LOW state to clean up the clock jitter, in order to drive the maximum cable length to the Sink.

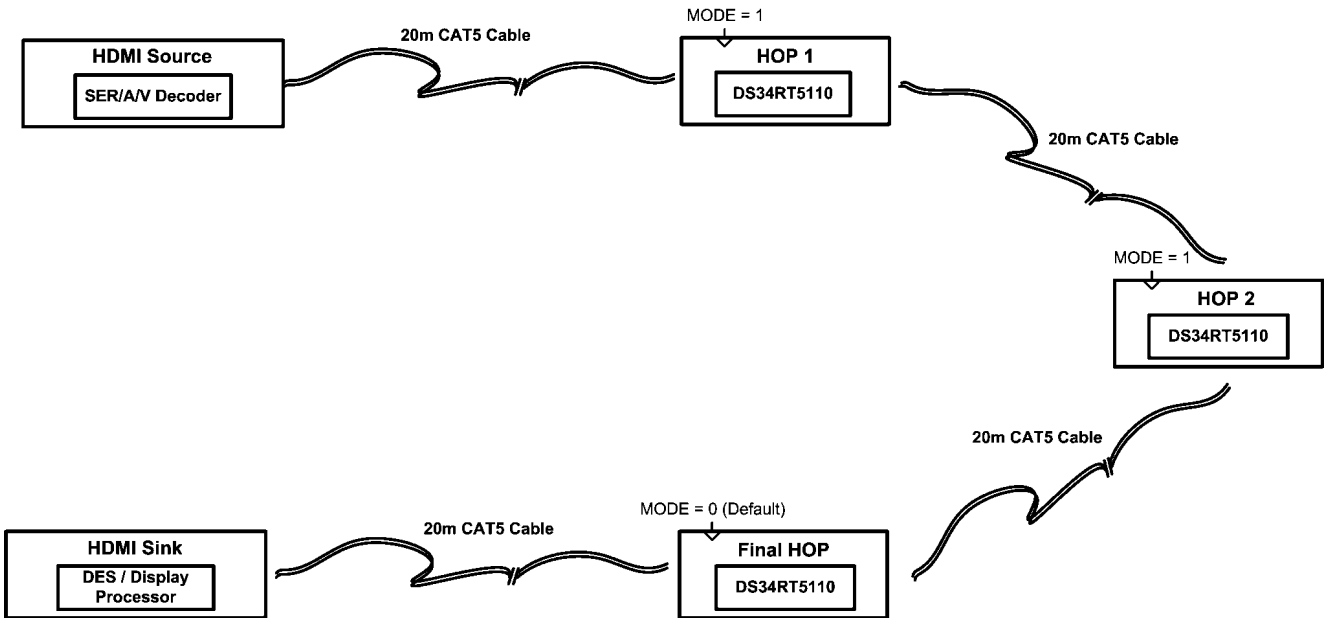

30087317

FIGURE 9. Multiple Hop Systems

### MATRIX SWITCH APPLICATION

For the security system with matrix DVI/HDMI switches, the DS34RT5110 is ideal to equalize the long cable reach re-

quirement from the Sources, clean the system jitter due to the complexity of PCB routings, and regenerate clean TMDS signals to the Sinks as shown in Figure 10.

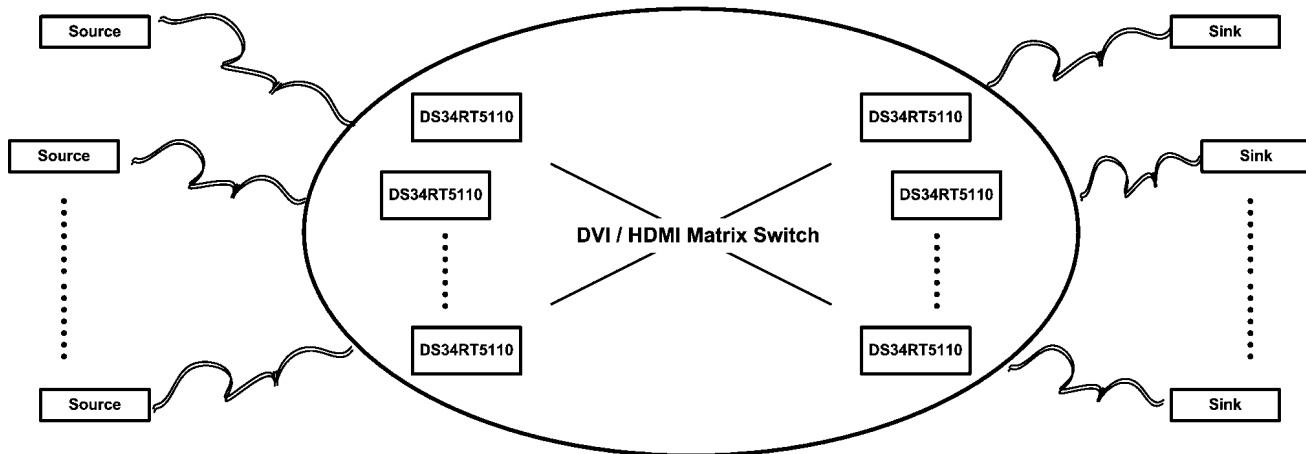

30087318

FIGURE 10. Matrix Switch Systems

### DUAL LINK APPLICATION

The DS34RT5110 supports DVI dual link applications requiring ultra-high resolutions for QXGA and WQXGA. Two

DS34RT5110 devices are configured as shown in Figure 11. This configuration is only recommended for a single dual link repeater application.

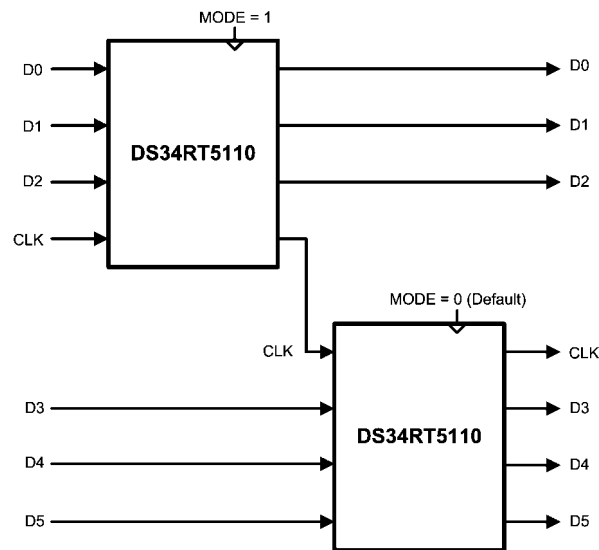

30087319

FIGURE 11. DVI/HDMI Dual Link Application

### DC AND AC COUPLED APPLICATIONS

The DS34RT5110 is designed to support TMDS differential pairs with DC coupled transmission lines. It contains integrated termination resistors ( $50\Omega$ ), pulled up to VDD at the input stage, and open collector outputs for DVI / HDMI signaling. Figure 12 shows the DC coupled connection between the HDMI Source (ie. DS34RT5110) and HDMI Sink (ie. DS34RT5110) devices. In the DC coupled application, the external resistance of  $24\text{ k}\Omega$  at VOD\_CRL pin is used at the Source to ensure the VO level of  $1000\text{ mVp-p}$ . The AC coupled method connecting between the Source and the Sink devices may be preferred to eliminate the impact of the

ground potential difference, or to use one CAT5/6 cable between two chassis. To optimize the DS34RT5110 performance, the external resistance of  $12\text{ k}\Omega$  at the VOD\_CRL pin should be used on the Source DS34RT5110, and a pair of  $50\Omega$  pull-up resistors should be placed close to the outputs of the Source DS34RT5110, in order to DC bias the output driver. Meanwhile,  $622\Omega$  pull-down resistors should be placed at the inputs of the Sink DS34RT5110 device, in order to set the input common mode to a  $3.05\text{ V}$ . Note AC coupled configuration is not compliant to the HDMI specification of Source requirement (See Figure 13).

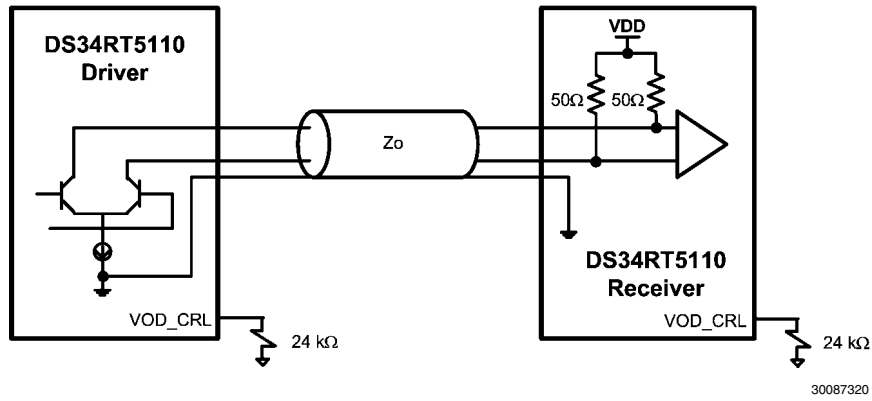

FIGURE 12. DC Coupled Application

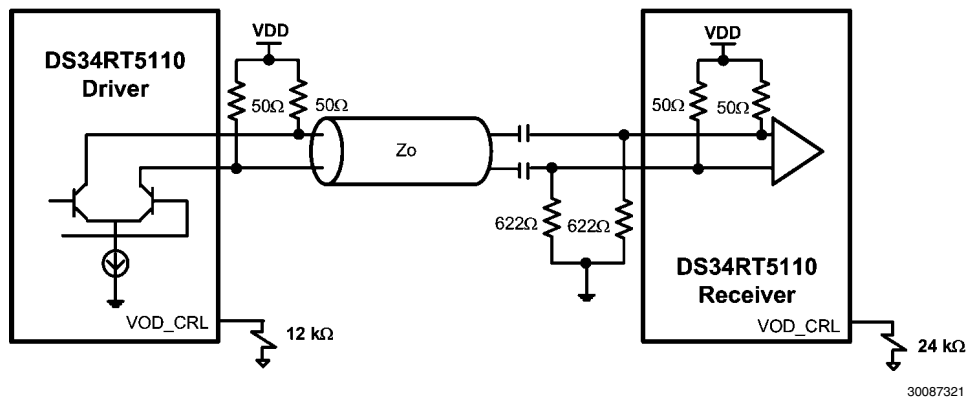

FIGURE 13. AC Coupled Application

**CABLE SELECTION AND INTER-PAIR SKEW**

DVI v1.0 and HDMI v1.3a specify Inter-Pair Skew requirements for the system. The DS34RT5110 intends to extend the longer cable reach with STP (DVI / HDMI) cable, or UTP (Cat5 / Cat5e / Cat6) cable, and it does not have a de-skew function to compensate any cable Inter-Pair Skews. Long cable with Inter-Pair Skew exceeding the DVI / HDMI standard limit tolerance could cause system distortion. Therefore, National suggests the consideration of Inter-Pair Skew budget during the system design, and recommends Low-Skew Video grade cables for cable extending applications.

**28 AWG STP (SHIELDED TWIST PAIRS) DVI / HDMI CABLES RECOMMENDED EQ SETTINGS**

Table 4 provides the recommended EQ control settings for various data rates and cable lengths for 28 AWG DVI/HDMI compliant configurations. The EQ setting is made via three EQ [2:0] pins.

TABLE 4. EQ Control Setting for STP Cable

Format (Data Rate)	0 ~ 10m	> 10m
1080P 48-bit (3.4 Gbps)	Setting 0x01	Setting 0x06
1080P 36-bit (2.25 Gbps)	Setting 0x01	Setting 0x06
1080P (1.65 Gbps)	Setting 0x01	Setting 0x06
1080I (750 Mbps)	Setting 0x06	Setting 0x06

**24 AWG UTP (LOW SKEW UNSHIELDED TWIST PAIRS) CABLES**

The DS34RT5110 can be used to extend the length of low skew grade UTP cables, such as Cat5e and Cat6 to distances greater than 30 meters at 1.65 Gbps with < 0.20 UI of jitter. Note that for non-standard DVI/HDMI cables, the user must ensure the inter pair skew requirements are met. Table 5 shows the recommended EQ control settings for various data rates and cable lengths for UTP configurations.

TABLE 5. EQ Control Setting for UTP Cable

Format (Data Rate)	0 ~ 10m	> 10m
1080P 48-bit (3.4 Gbps)	Setting 0x01	Setting 0x05
1080P 36-bit (2.25 Gbps)	Setting 0x01	Setting 0x05
1080P (1.65 Gbps)	Setting 0x01	Setting 0x05
1080I (750 Mbps)	Setting 0x05	Setting 0x05

## General Recommendations

The DS34RT5110 is a high performance circuit capable of delivering excellent performance. To achieve optimal performance, careful attention must be paid to the details associated with high-speed design as well as providing a clean power supply. Refer to the LVDS Owner's Manual for more detailed information on high-speed design tips as well as many other available resources addressing signal integrity design issues.

### PCB LAYOUT CONSIDERATIONS FOR DIFFERENTIAL PAIRS

The TMDS differential inputs and outputs must have a controlled differential impedance of  $100\ \Omega$ . It is preferable to route TMDS lines exclusively on one layer of the board, particularly for the input traces. The use of vias should be avoided if possible. If vias must be used, they should be used sparingly and must be placed symmetrically for each side of a given differential pair. Route the TMDS signals away from other signals and noise sources on the printed circuit board. All traces of TMDS differential inputs and outputs must be equal in length to minimize intra-pair skew.

### LLP FOOTPRINT RECOMMENDATIONS

See National application note: AN-1187, "Leadless Lead-frame Package (LLP)" for additional information on LLP packages footprint and soldering information.

### POWER SUPPLY BYPASSING

Two approaches are recommended to ensure the DS34RT5110 is provided with an adequate power supply. First, the supply (VDD) and ground (GND) pins should be connected to power planes routed on adjacent layers of the printed circuit board. The layer thickness of the dielectric should be minimized so the VDD and GND planes create a low inductance supply with distributed capacitance. Second, careful attention to supply bypassing through the proper use of bypass capacitors is required. A  $0.1\ \mu\text{F}$  bypass capacitor should be connected to each VDD pin such that the capacitor is placed as close as possible to the DS34RT5110. Smaller body size capacitors can help facilitate proper component placement. Additionally, two capacitors with capacitance in the range of  $2.2\ \mu\text{F}$  to  $10\ \mu\text{F}$  should be incorporated in the power supply bypassing design as well. These capacitors can be either tantalum or an ultra-low ESR ceramic and should be placed as close as possible to the DS34RT5110.

### EQUIVALENT I/O STRUCTURES

Figure 14 shows the DS34RT5110 CML output structure and ESD protection circuitry.

Figure 15 shows the DS34RT5110 CML input structure and ESD protection circuitry.

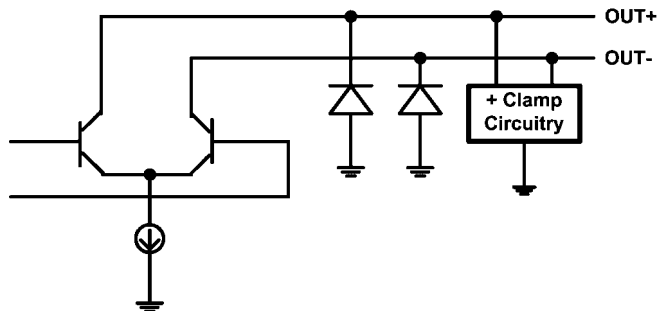

30087322

FIGURE 14. Equivalent Output Structure

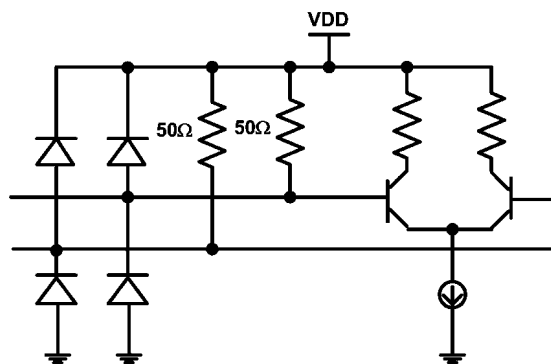

30087323

FIGURE 15. Equivalent Input Structure

## Typical Performance Characteristics as a Repeater

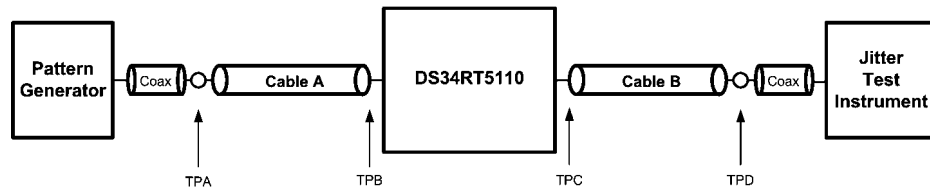

30087309

FIGURE 16. Simplified Test Setup as a Single Repeater

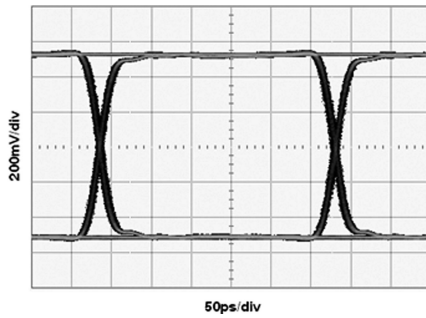

30087355

FIGURE 17. System Source Eye Diagram at TPA (3.4 Gbps)

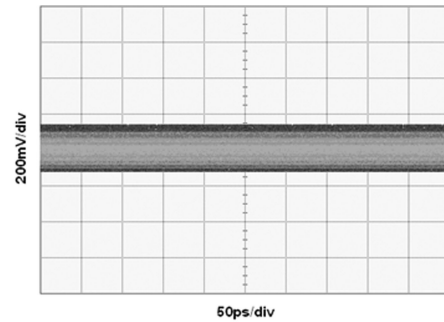

30087356

FIGURE 18. Device Sink Eye Diagram at TPB (3.4 Gbps, Cable A = 20m 28 AWG HDMI)

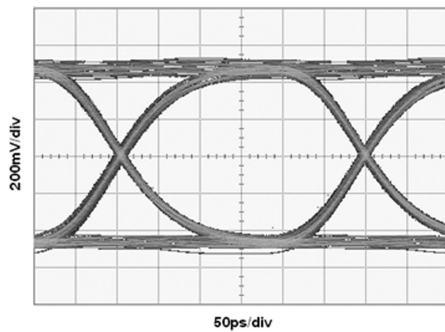

30087357

FIGURE 19. Device Source Eye Diagram at TPC (3.4 Gbps, Cable A = 20m 28 AWG HDMI, EQ = 0x05, BYPASS = 0, DE = 0dB)

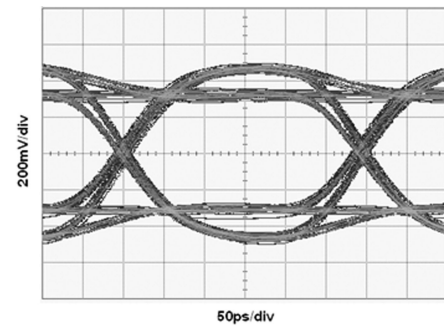

30087358

FIGURE 20. Device Source Eye Diagram at TPC (3.4 Gbps, Cable A = 20m 28 AWG HDMI, EQ = 0x05, BYPASS = 0, DE = -3dB)

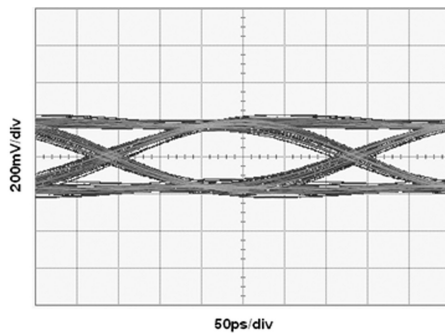

30087359

FIGURE 21. System Sink Eye Diagram at TPd (3.4 Gbps, Cable A = 20m 28 AWG HDMI, Cable B = 5m 28AWG HDMI, EQ = 0x05, BYPASS = 0, DE = -3dB)



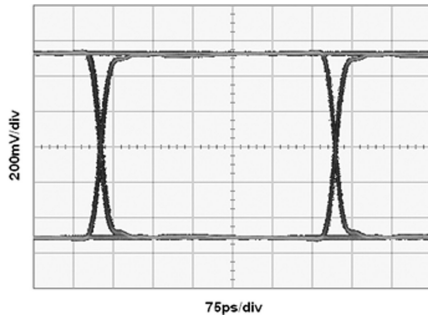

30087360  
**FIGURE 22. System Source Eye Diagram at TPA (2.25 Gbps)**

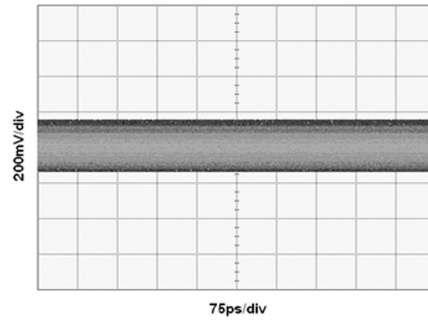

30087361  
**FIGURE 23. Device Sink Eye Diagram at TPB (2.25 Gbps, Cable A = 25m 28 AWG HDMI)**

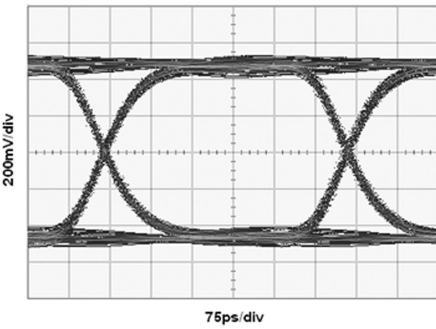

30087362  
**FIGURE 24. Device Source Eye Diagram at TPC (2.25 Gbps, Cable A = 25m 28 AWG HDMI, EQ = 0x05, BYPASS = 0, DE = 0dB)**

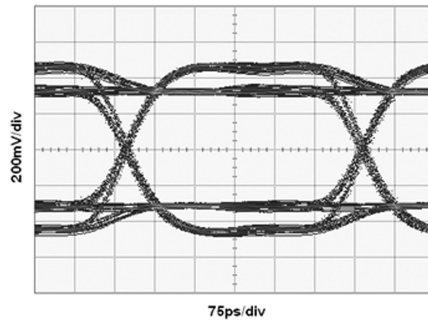

30087363  
**FIGURE 25. Device Source Eye Diagram at TPC (2.25 Gbps, Cable A = 25m 28 AWG HDMI, EQ = 0x05, BYPASS = 0, DE = -3dB)**

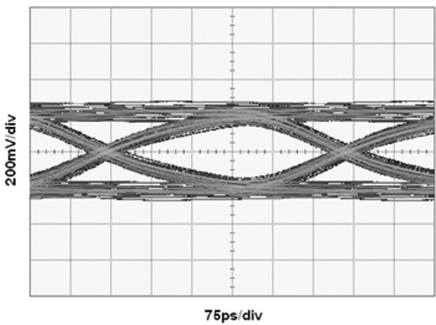

30087364  
**FIGURE 26. System Sink Eye Diagram at TPD (2.25 Gbps, Cable A = 25m 28 AWG HDMI, Cable B = 7.5m 28AWG HDMI, EQ = 0x05, BYPASS = 0, DE = -3dB)**

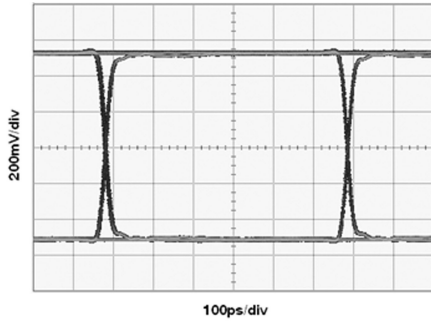

30087365  
**FIGURE 27. System Source Eye Diagram at TPA (1.65 Gbps)**

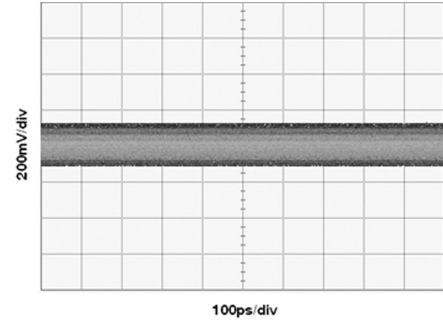

30087366  
**FIGURE 28. Device Sink Eye Diagram at TPB (1.65 Gbps, Cable A = 35m 28 AWG HDMI)**

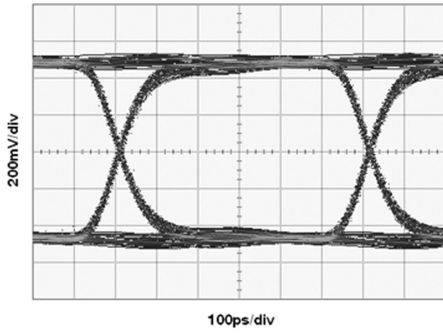

30087367  
**FIGURE 29. Device Source Eye Diagram at TPC (1.65 Gbps, Cable A = 35m 28 AWG HDMI, EQ = 0x05, BYPASS = 0, DE = 0dB)**

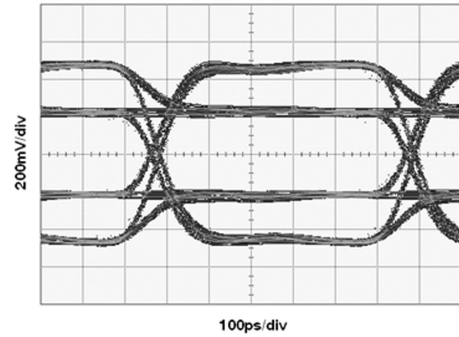

30087368  
**FIGURE 30. Device Source Eye Diagram at TPC (1.65 Gbps, Cable A = 35m 28 AWG HDMI, EQ = 0x05, BYPASS = 0, DE = -6dB)**

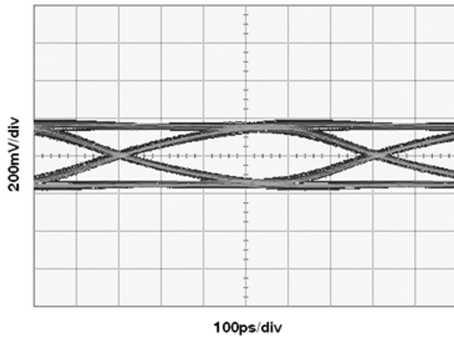

30087369  
**FIGURE 31. System Sink Eye Diagram at TPD (1.65 Gbps, Cable A = 35m 28 AWG HDMI, Cable B = 10m 28AWG HDMI, EQ = 0x05, BYPASS = 0, DE = -6dB)**

**Physical Dimensions** inches (millimeters) unless otherwise noted

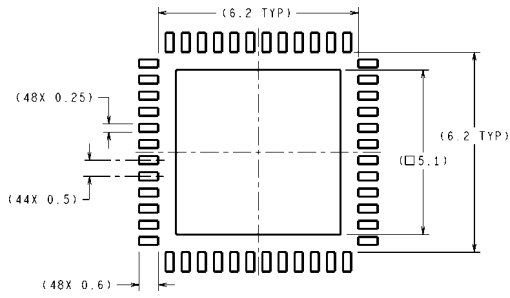

RECOMMENDED LAND PATTERN

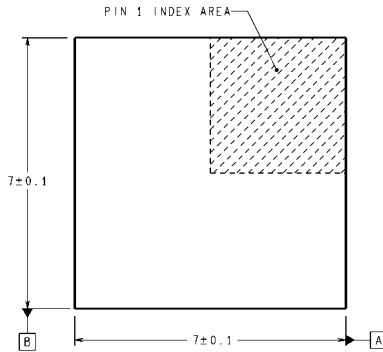

DIMENSIONS ARE IN MILLIMETERS  
DIMENSIONS IN ( ) FOR REFERENCE ONLY

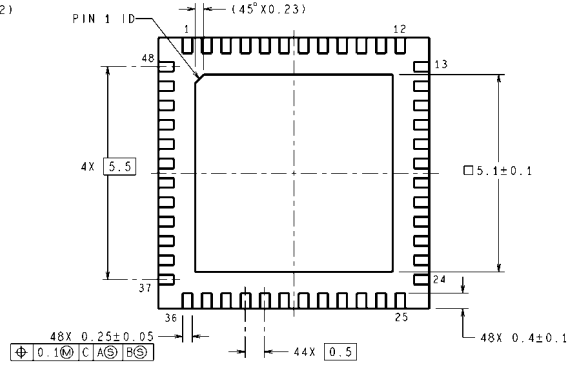
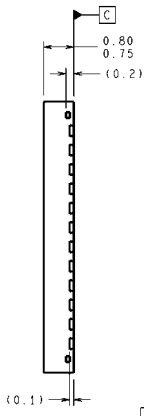

SQA48A (Rev B)

**7mm x 7mm 48-pin LLP Package**  
**Order Number DS34RT5110SQ**  
**Package Number SQA48A**

## Notes

For more National Semiconductor product information and proven design tools, visit the following Web sites at:  
[www.national.com](http://www.national.com)

Products		Design Support	
Amplifiers	<a href="http://www.national.com/amplifiers">www.national.com/amplifiers</a>	WEBENCH® Tools	<a href="http://www.national.com/webench">www.national.com/webench</a>
Audio	<a href="http://www.national.com/audio">www.national.com/audio</a>	App Notes	<a href="http://www.national.com/appnotes">www.national.com/appnotes</a>
Clock and Timing	<a href="http://www.national.com/timing">www.national.com/timing</a>	Reference Designs	<a href="http://www.national.com/refdesigns">www.national.com/refdesigns</a>
Data Converters	<a href="http://www.national.com/adc">www.national.com/adc</a>	Samples	<a href="http://www.national.com/samples">www.national.com/samples</a>
Interface	<a href="http://www.national.com/interface">www.national.com/interface</a>	Eval Boards	<a href="http://www.national.com/evalboards">www.national.com/evalboards</a>
LVDS	<a href="http://www.national.com/lvds">www.national.com/lvds</a>	Packaging	<a href="http://www.national.com/packaging">www.national.com/packaging</a>
Power Management	<a href="http://www.national.com/power">www.national.com/power</a>	Green Compliance	<a href="http://www.national.com/quality/green">www.national.com/quality/green</a>
Switching Regulators	<a href="http://www.national.com/switchers">www.national.com/switchers</a>	Distributors	<a href="http://www.national.com/contacts">www.national.com/contacts</a>
LDOs	<a href="http://www.national.com/ldo">www.national.com/ldo</a>	Quality and Reliability	<a href="http://www.national.com/quality">www.national.com/quality</a>
LED Lighting	<a href="http://www.national.com/led">www.national.com/led</a>	Feedback/Support	<a href="http://www.national.com/feedback">www.national.com/feedback</a>
Voltage References	<a href="http://www.national.com/vref">www.national.com/vref</a>	Design Made Easy	<a href="http://www.national.com/easy">www.national.com/easy</a>
PowerWise® Solutions	<a href="http://www.national.com/powerwise">www.national.com/powerwise</a>	Applications & Markets	<a href="http://www.national.com/solutions">www.national.com/solutions</a>
Serial Digital Interface (SDI)	<a href="http://www.national.com/sdi">www.national.com/sdi</a>	Mil/Aero	<a href="http://www.national.com/milaero">www.national.com/milaero</a>
Temperature Sensors	<a href="http://www.national.com/tempensors">www.national.com/tempensors</a>	SolarMagic™	<a href="http://www.national.com/solarmagic">www.national.com/solarmagic</a>
PLL/VCO	<a href="http://www.national.com/wireless">www.national.com/wireless</a>	PowerWise® Design University	<a href="http://www.national.com/training">www.national.com/training</a>

THE CONTENTS OF THIS DOCUMENT ARE PROVIDED IN CONNECTION WITH NATIONAL SEMICONDUCTOR CORPORATION ("NATIONAL") PRODUCTS. NATIONAL MAKES NO REPRESENTATIONS OR WARRANTIES WITH RESPECT TO THE ACCURACY OR COMPLETENESS OF THE CONTENTS OF THIS PUBLICATION AND RESERVES THE RIGHT TO MAKE CHANGES TO SPECIFICATIONS AND PRODUCT DESCRIPTIONS AT ANY TIME WITHOUT NOTICE. NO LICENSE, WHETHER EXPRESS, IMPLIED, ARISING BY ESTOPPEL OR OTHERWISE, TO ANY INTELLECTUAL PROPERTY RIGHTS IS GRANTED BY THIS DOCUMENT.

TESTING AND OTHER QUALITY CONTROLS ARE USED TO THE EXTENT NATIONAL DEEMS NECESSARY TO SUPPORT NATIONAL'S PRODUCT WARRANTY. EXCEPT WHERE MANDATED BY GOVERNMENT REQUIREMENTS, TESTING OF ALL PARAMETERS OF EACH PRODUCT IS NOT NECESSARILY PERFORMED. NATIONAL ASSUMES NO LIABILITY FOR APPLICATIONS ASSISTANCE OR BUYER PRODUCT DESIGN. BUYERS ARE RESPONSIBLE FOR THEIR PRODUCTS AND APPLICATIONS USING NATIONAL COMPONENTS. PRIOR TO USING OR DISTRIBUTING ANY PRODUCTS THAT INCLUDE NATIONAL COMPONENTS, BUYERS SHOULD PROVIDE ADEQUATE DESIGN, TESTING AND OPERATING SAFEGUARDS.

EXCEPT AS PROVIDED IN NATIONAL'S TERMS AND CONDITIONS OF SALE FOR SUCH PRODUCTS, NATIONAL ASSUMES NO LIABILITY WHATSOEVER, AND NATIONAL DISCLAIMS ANY EXPRESS OR IMPLIED WARRANTY RELATING TO THE SALE AND/OR USE OF NATIONAL PRODUCTS INCLUDING LIABILITY OR WARRANTIES RELATING TO FITNESS FOR A PARTICULAR PURPOSE, MERCHANTABILITY, OR INFRINGEMENT OF ANY PATENT, COPYRIGHT OR OTHER INTELLECTUAL PROPERTY RIGHT.

### LIFE SUPPORT POLICY

**NATIONAL'S PRODUCTS ARE NOT AUTHORIZED FOR USE AS CRITICAL COMPONENTS IN LIFE SUPPORT DEVICES OR SYSTEMS WITHOUT THE EXPRESS PRIOR WRITTEN APPROVAL OF THE CHIEF EXECUTIVE OFFICER AND GENERAL COUNSEL OF NATIONAL SEMICONDUCTOR CORPORATION.** As used herein:

Life support devices or systems are devices which (a) are intended for surgical implant into the body, or (b) support or sustain life and whose failure to perform when properly used in accordance with instructions for use provided in the labeling can be reasonably expected to result in a significant injury to the user. A critical component is any component in a life support device or system whose failure to perform can be reasonably expected to cause the failure of the life support device or system or to affect its safety or effectiveness.

National Semiconductor and the National Semiconductor logo are registered trademarks of National Semiconductor Corporation. All other brand or product names may be trademarks or registered trademarks of their respective holders.

Copyright© 2010 National Semiconductor Corporation

For the most current product information visit us at [www.national.com](http://www.national.com)



**National Semiconductor Americas Technical Support Center**  
 Email: [support@nsc.com](mailto:support@nsc.com)  
 Tel: 1-800-272-9959

**National Semiconductor Europe Technical Support Center**  
 Email: [europe.support@nsc.com](mailto:europe.support@nsc.com)

**National Semiconductor Asia Pacific Technical Support Center**  
 Email: [ap.support@nsc.com](mailto:ap.support@nsc.com)

**National Semiconductor Japan Technical Support Center**  
 Email: [jpn.feedback@nsc.com](mailto:jpn.feedback@nsc.com)