

LF111/LF211/LF311 Voltage Comparators

General Description

The LF111, LF211 and LF311 are FET input voltage comparators that virtually eliminate input current errors. Designed to operate over a 5.0V to $\pm 15V$ range the LF111 can be used in the most critical applications.

The extremely low input currents of the LF111 allows the use of a simple comparator in applications usually requiring input current buffering. Leakage testing, long time delay circuits, charge measurements, and high source impedance voltage comparisons are easily done.

Further, the LF111 can be used in place of the LM111 eliminating errors due to input currents. See the "application hints" of the LM311 for application help.

Features

- Eliminates input current errors
- Interchangeable with LM111
- No need for input current buffering

Schematic Diagram

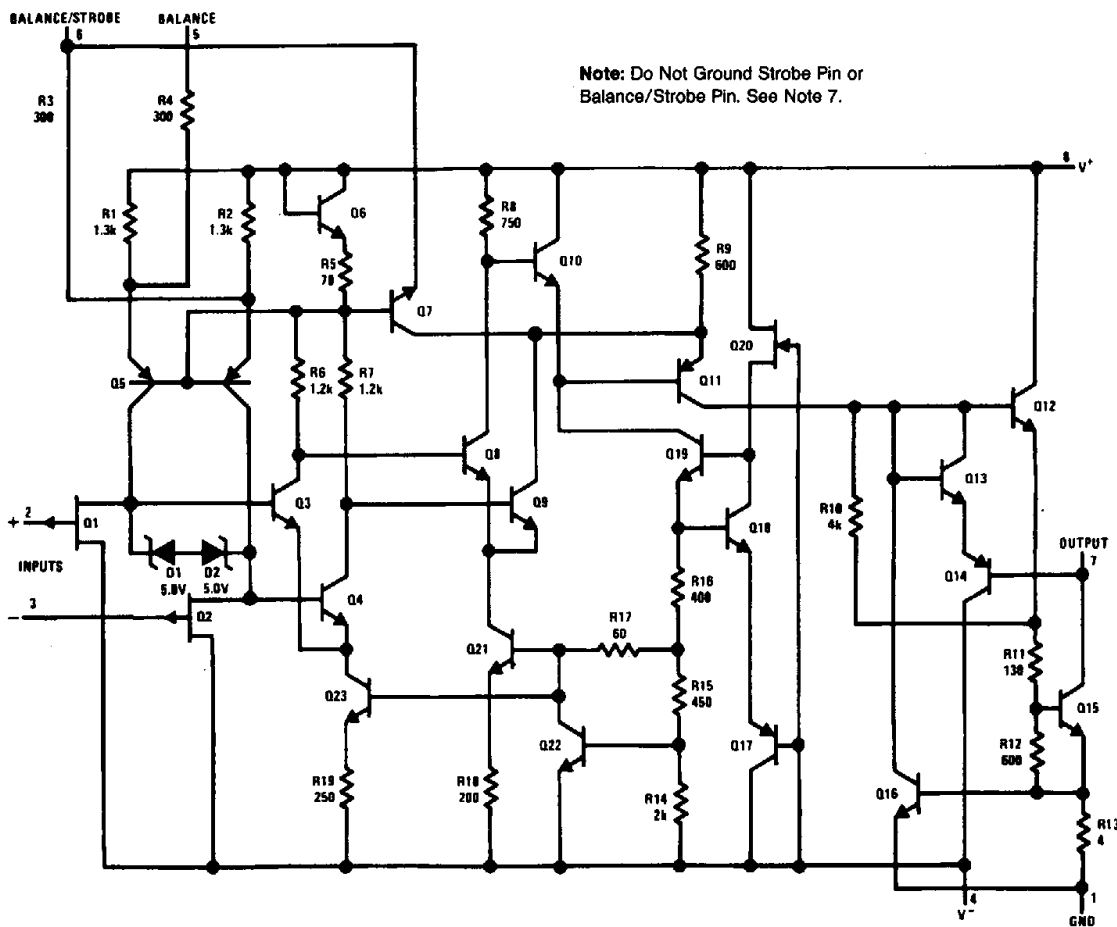

Note: Do Not Ground Strobe Pin or Balance/Strobe Pin. See Note 7.

Connection Diagram

TL/H/5703-2

Metal Can Package

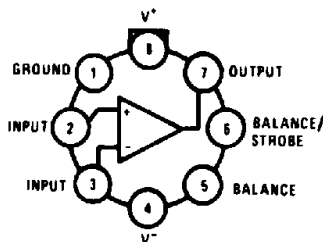

TL/H/5703-1

Top View

Order Number LF111H, LF111H-MIL or LF311H
See NS Package Number H08C

Absolute Maximum Ratings

If Military/Aerospace specified devices are required, please contact the National Semiconductor Sales Office/Distributors for availability and specifications.

(Note 8)

	LF111/LF211	LF311	Operating Temp. Range	LF111/LF211	LF311
Total Supply Voltage (V_{B4})	36V	36V	LF111	-55°C to +125°C	
Output to Negative Supply Voltage (V_{74})	50V	40V	LF211	-25°C to +85°C	
Ground to Negative Supply Voltage (V_{14})	30V	30V	LF311		0°C to +70°C
Differential Input Voltage	±30V	±30V	Storage Temp. Range	-65°C to +150°C	-65°C to +150°C
Input Voltage (Note 1)	±15V	±15V	Lead Temp. (Soldering, 10 seconds)	260°C	260°C
Power Dissipation (Note 2)	500 mW	500 mW	ESD rating to be determined.		
Output Short Circuit Duration	10 seconds	10 seconds			

Electrical Characteristics (LF111/LF211) (Note 3)

Parameter	Conditions	Min	Typ	Max	Units
Input Offset Voltage (Note 4)	$T_A = 25^\circ\text{C}$, $R_S \leq 50\text{k}$		0.7	4.0	mV
Input Offset Current (Note 4)	$T_A = 25^\circ\text{C}$, $V_{CM} = 0$ (Note 6)		5.0	25	pA
Input Bias Current	$T_A = 25^\circ\text{C}$, $V_{CM} = 0$ (Note 6)		20	50	pA
Voltage Gain	$T_A = 25^\circ\text{C}$	40	200		V/mV
Response Time (Note 5)	$T_A = 25^\circ\text{C}$		200		ns
Saturation Voltage	$V_{IN} \leq -5.0\text{ mV}$, $I_{OUT} = 50\text{ mA}$, $T_A = 25^\circ\text{C}$		0.75	1.5	V
Strobe On Current	$T_A = 25^\circ\text{C}$		3.0		mA
Output Leakage Current	$V_{IN} \leq 5.0\text{ mV}$, $V_{OUT} = 35\text{V}$, $T_A = 25^\circ\text{C}$		0.2	10	nA
Input Offset Voltage (Note 4)	$R_S \leq 50\text{k}$			6.0	mV
Input Offset Current (Note 4)	$V_S = \pm 15\text{V}$, $V_{CM} = 0$ (Note 6)		2.0	3.0	nA
Input Bias Current	$V_S = \pm 15\text{V}$, $V_{CM} = 0$ (Note 6)		5.0	7.0	nA
Input Voltage Range		-13.5	±14	13.0	V
Saturation Voltage	$V^+ \geq 4.5\text{V}$, $V^- = 0$ $V_{IN} \leq -6.0\text{ mV}$, $I_{OUT} \leq 8.0\text{ mA}$		0.23	0.4	V
Output Leakage Current	$V_{IN} \geq 5.0\text{ mV}$, $V_{OUT} = 35\text{V}$		0.1	0.5	μA
Positive Supply Current	$T_A = 25^\circ\text{C}$		5.1	6.0	mA
Negative Supply Current	$T_A = 25^\circ\text{C}$		4.1	5.0	mA

Note 1: This rating applies for ±15V supplies. The positive input voltage limit is 30V above the negative supply. The negative input voltage limit is equal to the negative supply voltage or 30V below the positive supply, whichever is less.

Note 2: The maximum junction temperature of the LF111 is +150°C, the LF211 is +110°C and the LF311 is +85°C. For operating at elevated temperatures, devices in the H08 package must be derated based on a thermal resistance of +65°C/W junction to ambient (in 400 linear feet/min air flow), +165°C/W junction to ambient (in static air), or +20°C/W junction to case.

Note 3: These specifications apply for $V_S = \pm 15\text{V}$, and the Ground pin at ground, and $-55^\circ\text{C} \leq T_A \leq +125^\circ\text{C}$ for the LF111, unless otherwise stated. With the LF211, however, all temperature specifications are limited to $-25^\circ\text{C} \leq T_A \leq +85^\circ\text{C}$ and for the LF311 $0^\circ\text{C} \leq T_A \leq +70^\circ\text{C}$. The offset voltage, offset current and bias current specifications apply for any supply voltage from a single 5.0V supply up to ±15V supplies.

Note 4: The offset voltages and offset currents given are the maximum values required to drive the output within a volt of either supply with a 1.0 mA load. Thus, these parameters define an error band and take into account the worst case effects of voltage gain and input impedance.

Note 5: The response time specified (see definitions) is for a 100 mV input step with 5.0 mV overdrive.

Note 6: For input voltages greater than 15V above the negative supply the bias and offset currents will increase—see typical performance curves.

Note 7: This specification gives the current that must be drawn from the strobe pin to ensure the output is properly disabled. Do not short the strobe pin to ground; it should be current driven at 3 to 5 mA.

Note 8: Refer to RETSF111X for LF111H military specifications.

Electrical Characteristics (LF311) (Note 3)

Parameter	Conditions	Min	Typ	Max	Units
Input Offset Voltage (Note 4)	$T_A = 25^\circ\text{C}$, $R_S \leq 50\text{k}$		2.0	10	mV
Input Offset Current (Note 4)	$T_A = 25^\circ\text{C}$, $V_{CM} = 0$ (Note 6)		5.0	75	pA
Input Bias Current	$T_A = 25^\circ\text{C}$, $V_{CM} = 0$ (Note 6)		25	150	pA
Voltage Gain	$T_A = 25^\circ\text{C}$		200		V/mV
Response Time (Note 5)	$T_A = 25^\circ\text{C}$		200		ns
Saturation Voltage	$V_{IN} \leq -10\text{ mV}$, $I_{OUT} = 50\text{ mA}$, $T_A = 25^\circ\text{C}$		0.75	1.5	V
Strobe On Current	$T_A = 25^\circ\text{C}$		3.0		mA
Output Leakage Current	$V_{IN} \geq 10\text{ mV}$, $V_{OUT} = 35\text{ V}$, $T_A = 25^\circ\text{C}$		0.2	10	nA
Input Offset Voltage (Note 4)	$R_S \leq 50\text{k}$			15	mV
Input Offset Current (Note 4)	$V_S = \pm 15\text{ V}$, $V_{CM} = 0$ (Note 6)		1.0		nA
Input Bias Current	$V_S = 15\text{ V}$, $V_{CM} = 0$ (Note 6)		3.0		nA
Input Voltage Range			+14 -13.5		V V
Saturation Voltage	$V^+ \geq 4.5\text{ V}$, $V^- = 0$ $V_{IN} \leq -10\text{ mV}$, $I_{OUT} \leq 8.0\text{ mA}$		0.23	0.4	V
Positive Supply Current	$T_A = 25^\circ\text{C}$		5.1	7.5	mA
Negative Supply Current	$T_A = 25^\circ\text{C}$		4.1	5.0	mA

Note 1: This rating applies for $\pm 15\text{ V}$ supplies. The positive input voltage limit is 30V above the negative supply. The negative input voltage limit is equal to the negative supply voltage or 30V below the positive supply, whichever is less.

Note 2: The maximum junction temperature of the LF111 is $+150^\circ\text{C}$, the LF211 is $+110^\circ\text{C}$ and the LF311 is $+85^\circ\text{C}$. For operating at elevated temperatures, devices in the H08 package must be derated based on a thermal resistance of $+165^\circ\text{C/W}$, junction to ambient, or $+20^\circ\text{C/W}$, junction to case.

Note 3: These specifications apply for $V_S = \pm 15\text{ V}$ and $-55^\circ\text{C} \leq T_A \leq +125^\circ\text{C}$ for the LF111, unless otherwise stated. With the LF211, however, all temperature specifications are limited to $-25^\circ\text{C} \leq T_A \leq +85^\circ\text{C}$ and for the LF311 $0^\circ\text{C} \leq T_A \leq +70^\circ\text{C}$. The offset voltage, offset current and bias current specifications apply for any supply voltage from a single 5.0 mV supply up to $\pm 15\text{ V}$ supplies.

Note 4: The offset voltages and offset currents given are the maximum values required to drive the output within a volt of either supply with a 1.0 mA load. Thus, these parameters define an error band and take into account the worst case effects of voltage gain and input impedance.

Note 5: The response time specified (see definitions) is for a 100 mV input step with 5.0 mV overdrive.

Note 6: For input voltages greater than 15V above the negative supply the bias and offset currents will increase—see typical performance curves.

Note 7: This specification gives the current that must be drawn from the strobe pin to ensure the output is properly disabled. Do not short the strobe pin to ground; it should be current driven at 3 to 5 mA.

Auxiliary Circuits

Offset Balancing

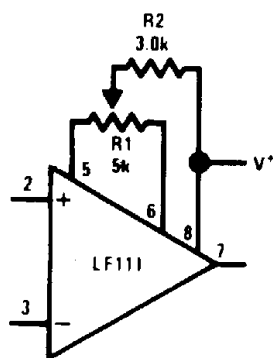

TL/H/5703-13

Strobing

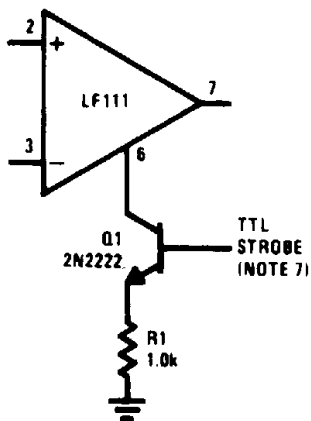

TL/H/5703-14

Note: Do Not Ground Strobe Pin.

Increasing Input Stage Current*

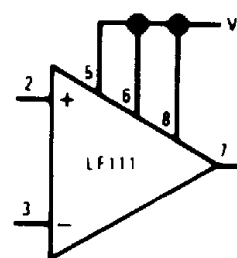

TL/H/5703-15

*Increases typical common mode slew from 7.0V/ μs to 18V/ μs

Typical Performance Characteristics

Input Bias Current vs Common Mode

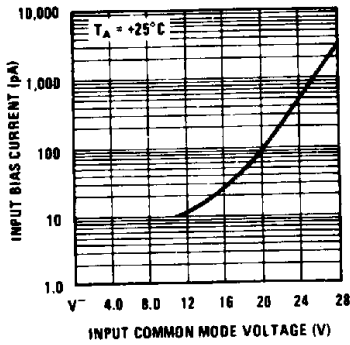

Input Bias Current vs Temperature

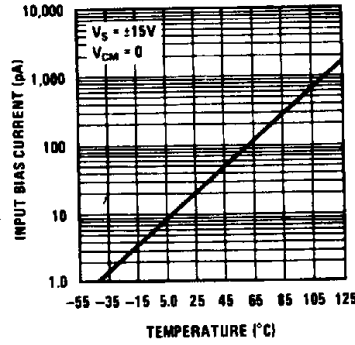

Transfer Function

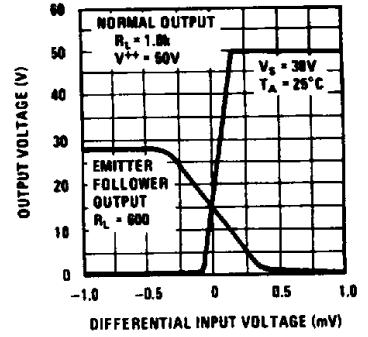

Response Time for Various Input Overdrives

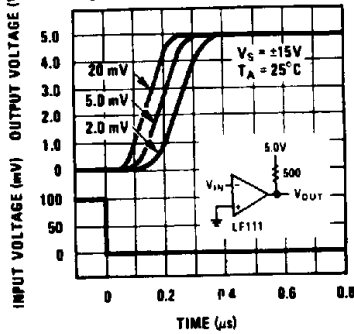

Response Time for Various Input Overdrives

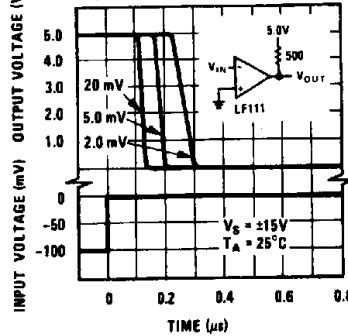

Output Saturation Voltage

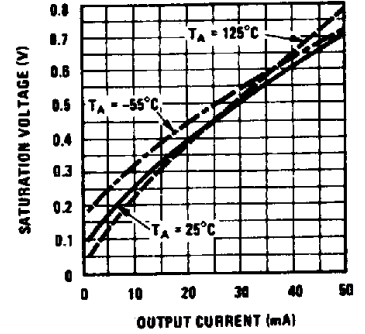

Response Time for Various Input Overdrives

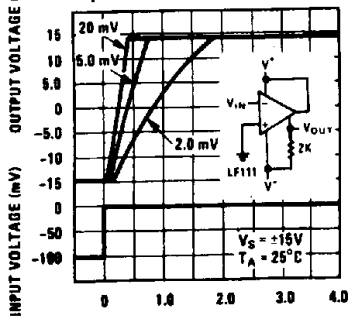

Response Time for Various Input Overdrives

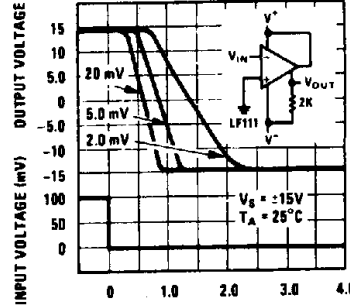

Supply Current

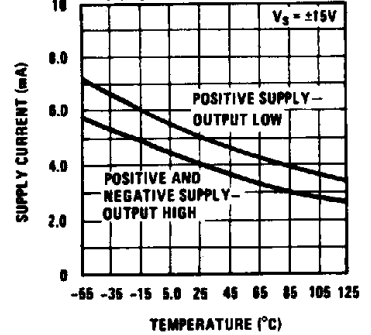

Output Limiting Characteristics

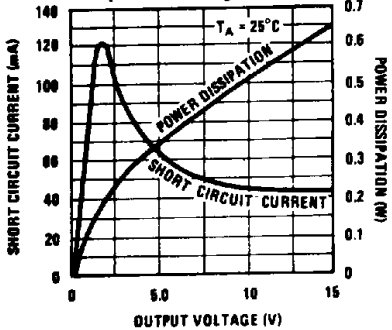

Supply Current

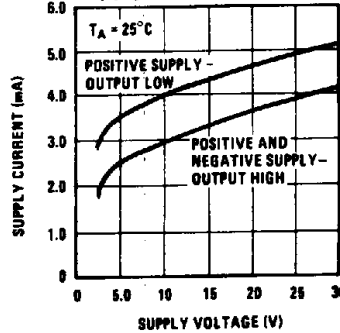

Leakage Currents

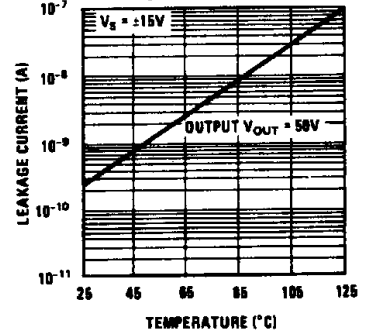

TL/H/5703-4

Typical Applications

LF111/LF211/LF311

100 kHz Free Running Multivibrator

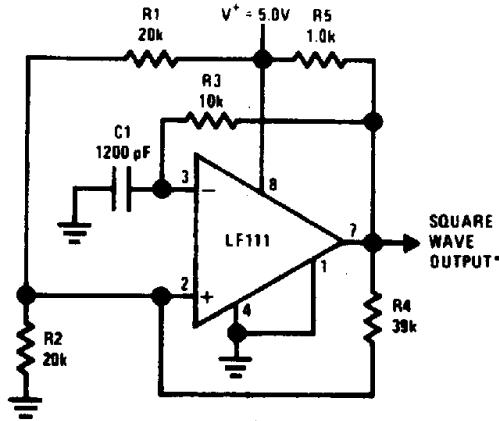

TL/H/5703-7

*TTL or DTL fanout of two.

Crystal Oscillator

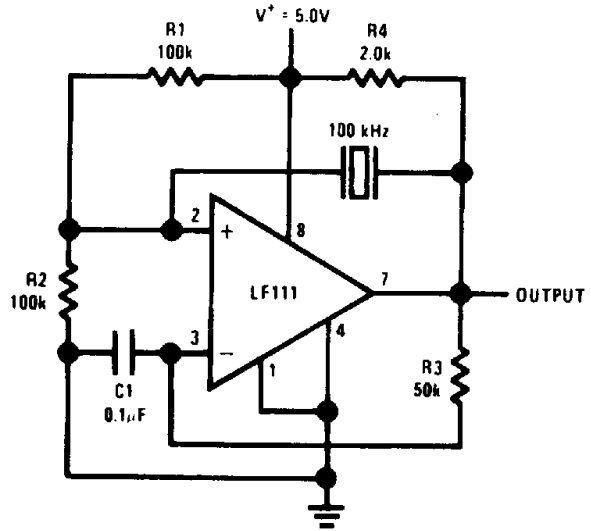

TL/H/5703-3

10 Hz to 10 kHz Voltage Controlled Oscillator

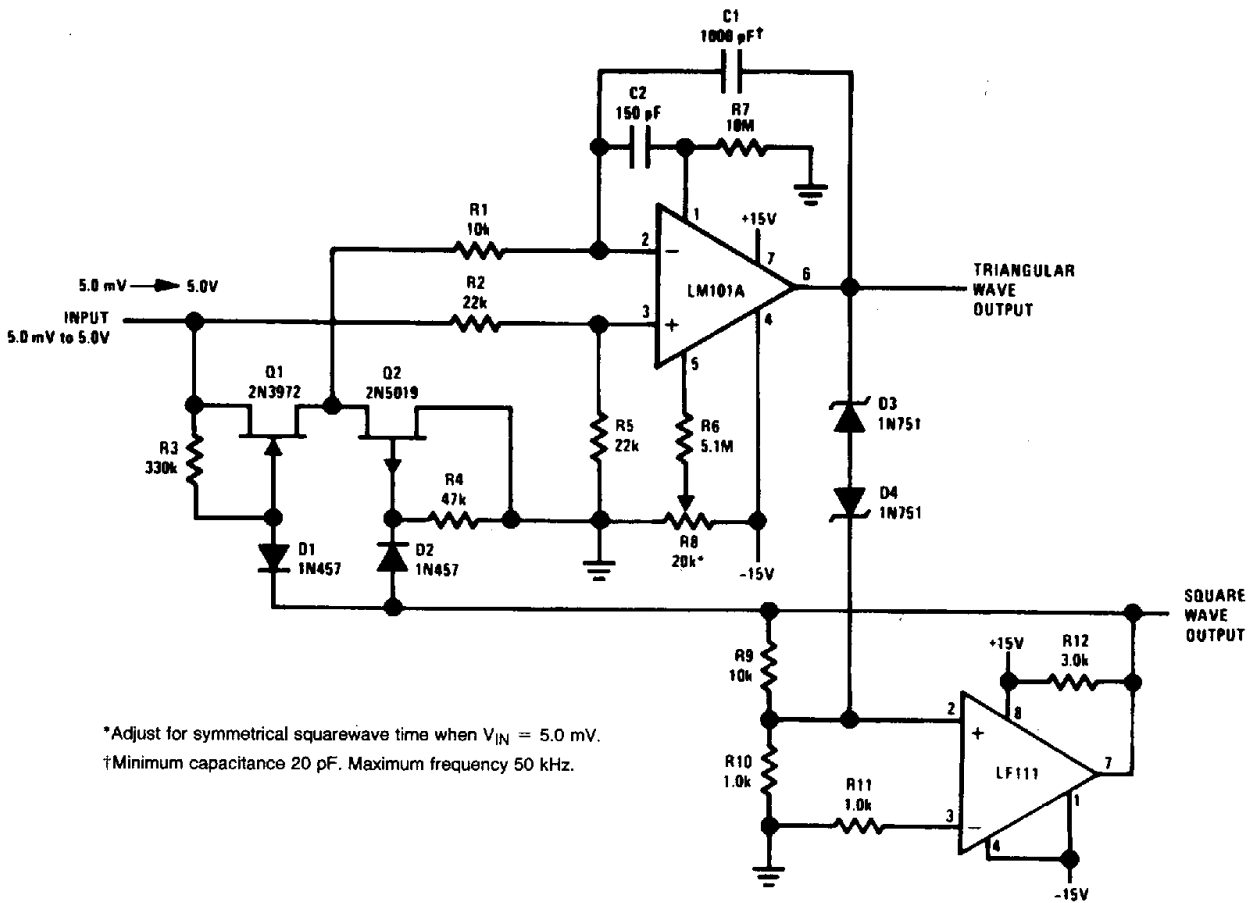

*Adjust for symmetrical squarewave time when $V_{IN} = 5.0$ mV.

†Minimum capacitance 20 pF. Maximum frequency 50 kHz.

TL/H/5703-5

3

Typical Applications (Continued)

Frequency Doubler

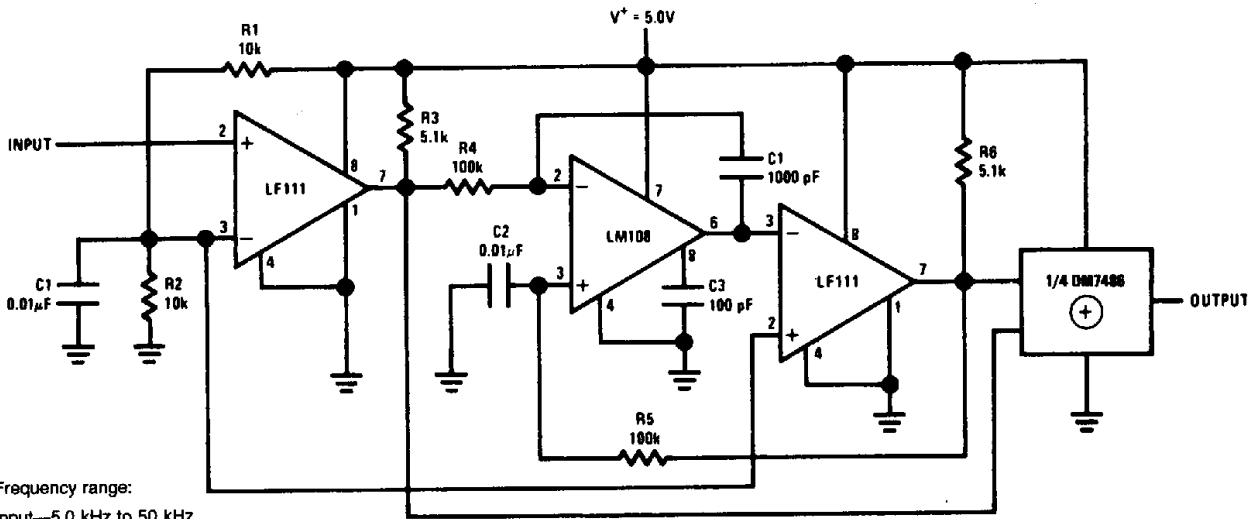

Frequency range:
 Input—5.0 kHz to 50 kHz
 Output—10 kHz to 100 kHz

TL/H/5703-8

Zero Crossing Detector Driving MOS Switch

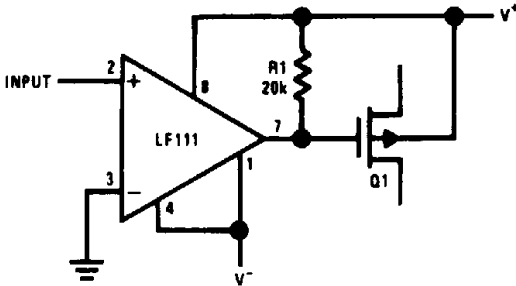

TL/H/5703-9

Zero Crossing Detector Driving MOS Logic

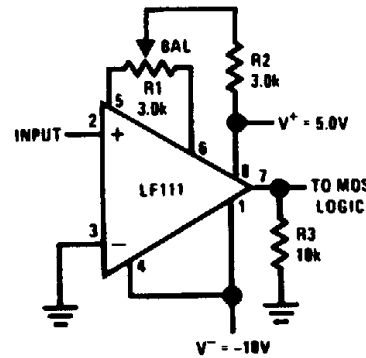

TL/H/5703-10

Driving Ground-Referred Load

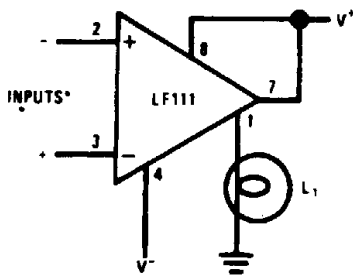

TL/H/5703-11

*Input polarity is reversed when using pin 1 as output.

Comparator and Solenoid Driver

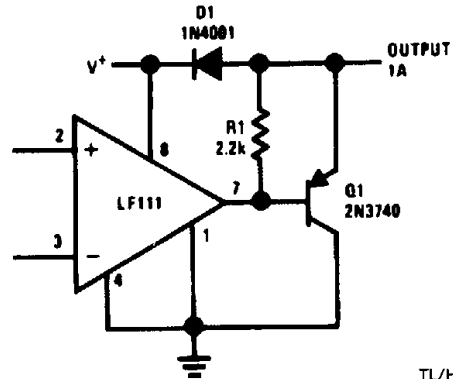

TL/H/5703-12

Typical Applications (Continued)

Switching Power Amplifier

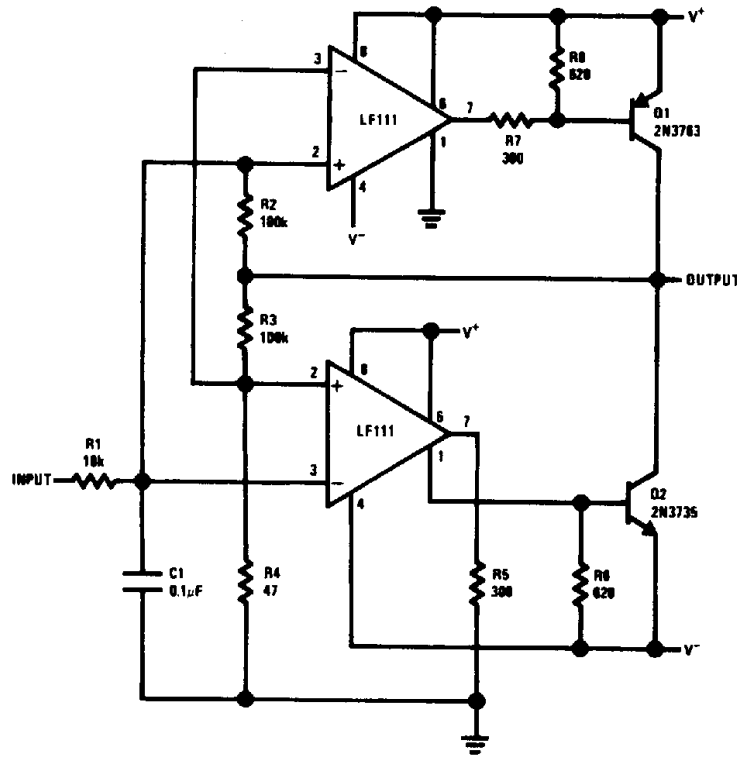

TL/H/5703-16

Switching Power Amplifier

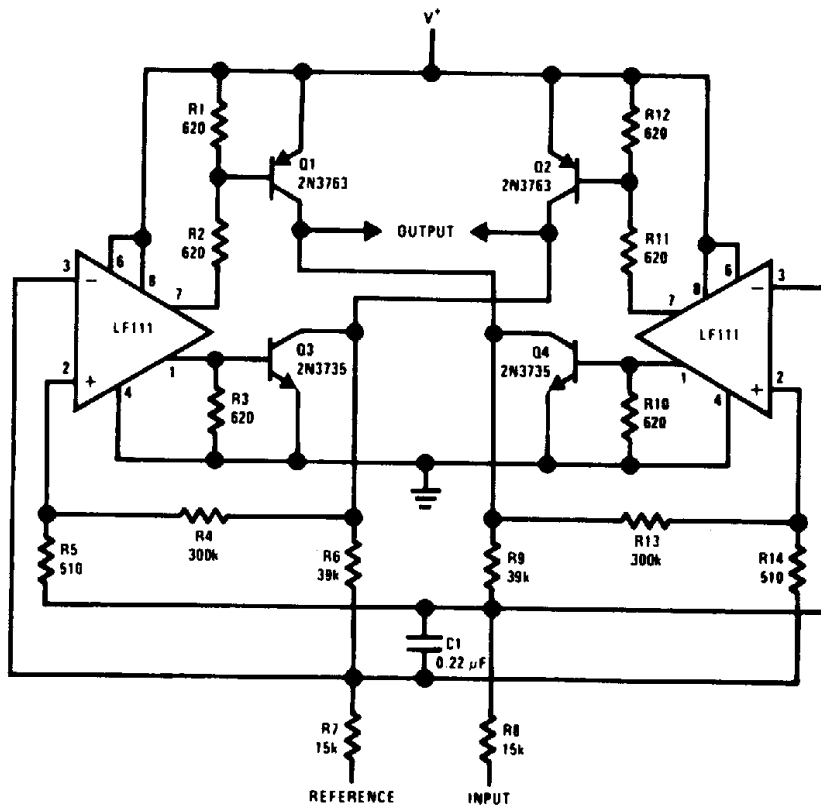

TL/H/5703-17

Typical Applications (Continued)

Relay Driver with Strobe

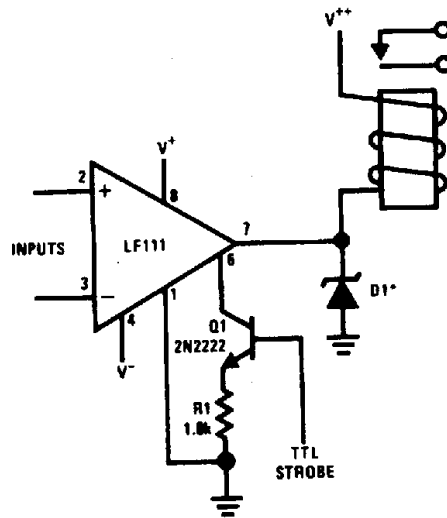

*Absorbs inductive kickback of relay and protects IC from severe voltage transients on V⁺ line.

TL/H/5703-18

Note: Do Not Ground Strobe Pin.

Positive Peak Detector

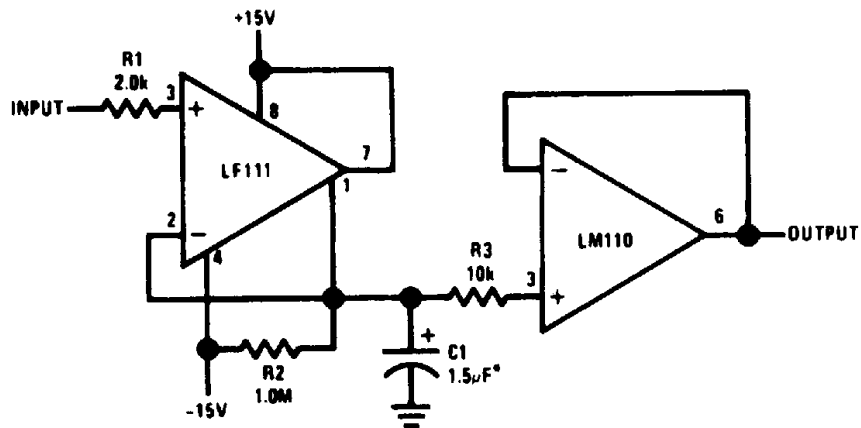

*Solid tantalum

TL/H/5703-19

Negative Peak Detector

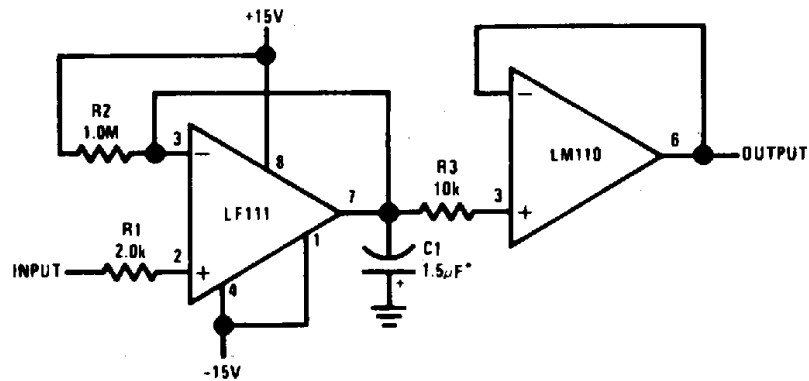

*Solid tantalum

TL/H/5703-20

Typical Applications (Continued)

TTL Interface with High Level Logic

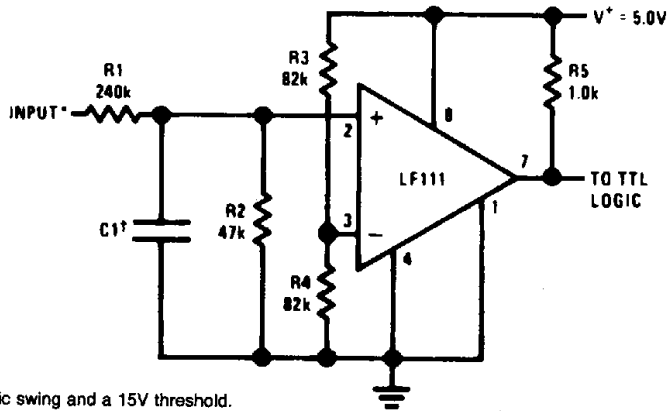

*Values shown are for a 0 to 30V logic swing and a 15V threshold.

†May be added to control speed and reduce susceptibility to noise spikes

TL/H/5703-21

Using Clamp Diodes to Improve Response

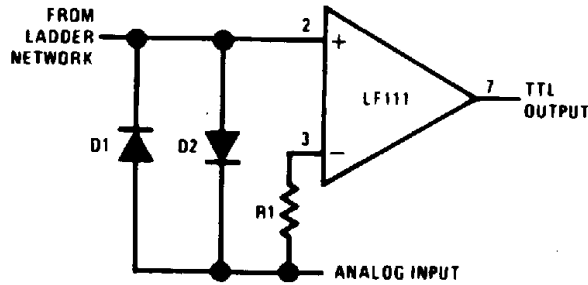

TL/H/5703-6