



TDA7469

LOW VOLTAGE ANALOG AUDIO PROCESSOR WITH HEADPHONE POWER AMPLIFIER

1 FEATURES

- 2 STEREO INPUT
- 1 STEREO OUTPUT
- TREBLE BOOST
- BASS CONTROL
- BASS AUTOMATIC LEVEL CONTROL
- VOLUME CONTROL IN 1dB STEPS
- MUTE
- STAND-BY FUNCTION SOFTWARE CONTROLLED
- ALL FUNCTION ARE PROGRAMMABLE VIA SERIAL BUS

2 DESCRIPTION

The TDA7469 is a volume tone (bass and treble) processor for quality audio applications in Low voltage supply portable systems.

Bass ALC (Automatic Level Control) function can be adjusted by a dedicated pin. The control of all the functions is accomplished by serial bus.

Figure 1. Package



Table 1. Order Codes

Part Number	Package
TDA7469	SSOP24
TDA746913TR	Tape & Reel

The AC signal setting is obtained by resistor networks and switches combined with operational amplifiers.

Thanks to the used BIPOLAR/CMOS Technology, Low Distortion, Low Noise and DC stepping are obtained.

Figure 2. Block Diagram

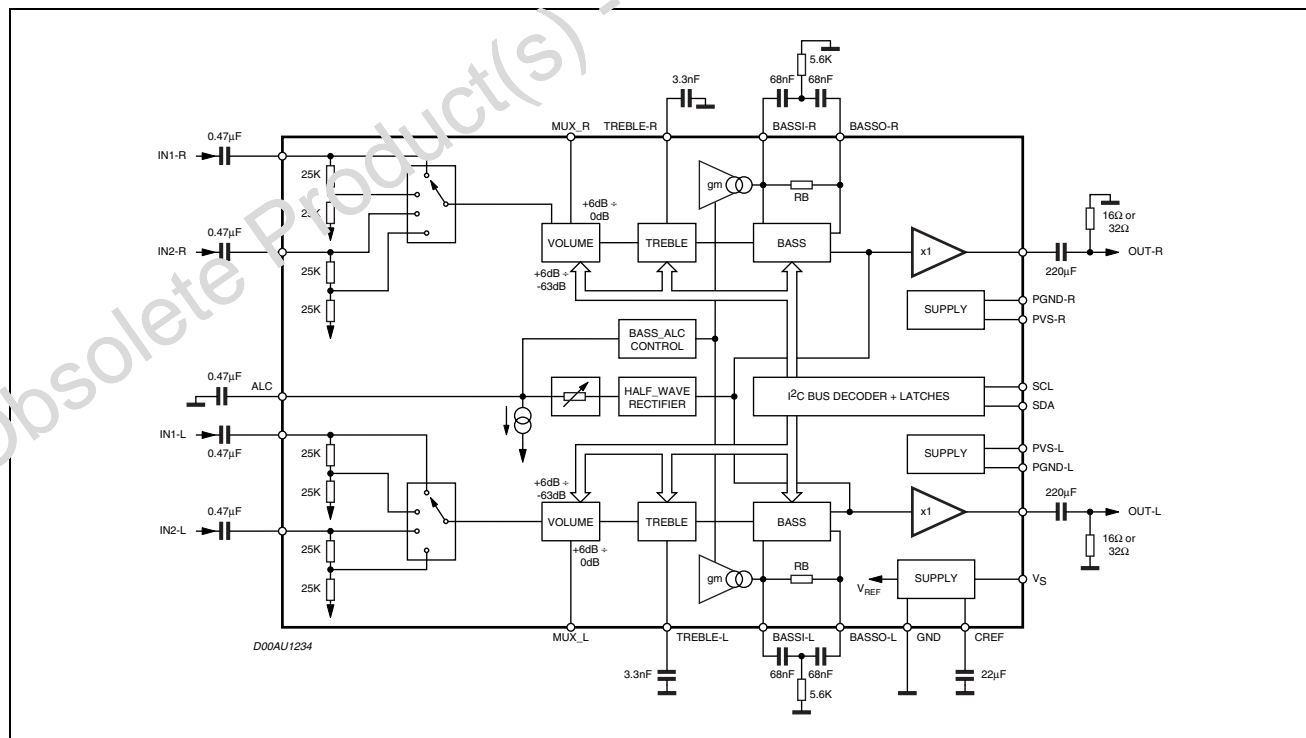

Table 2. ABSOLUTE MAXIMUM RATINGS

Symbol	Parameter	Value	Unit
V _S	Operating Supply Voltage	5.5	V
T _{amb}	Operating Ambient Temperature	0 to 70	°C
T _{stg}	Storage Temperature Range	-55 to 150	°C
ESD	Maximum ESD on PINS 11 and 12 (HBM)	500	V

Figure 3. PIN CONNECTIONS (Top view)

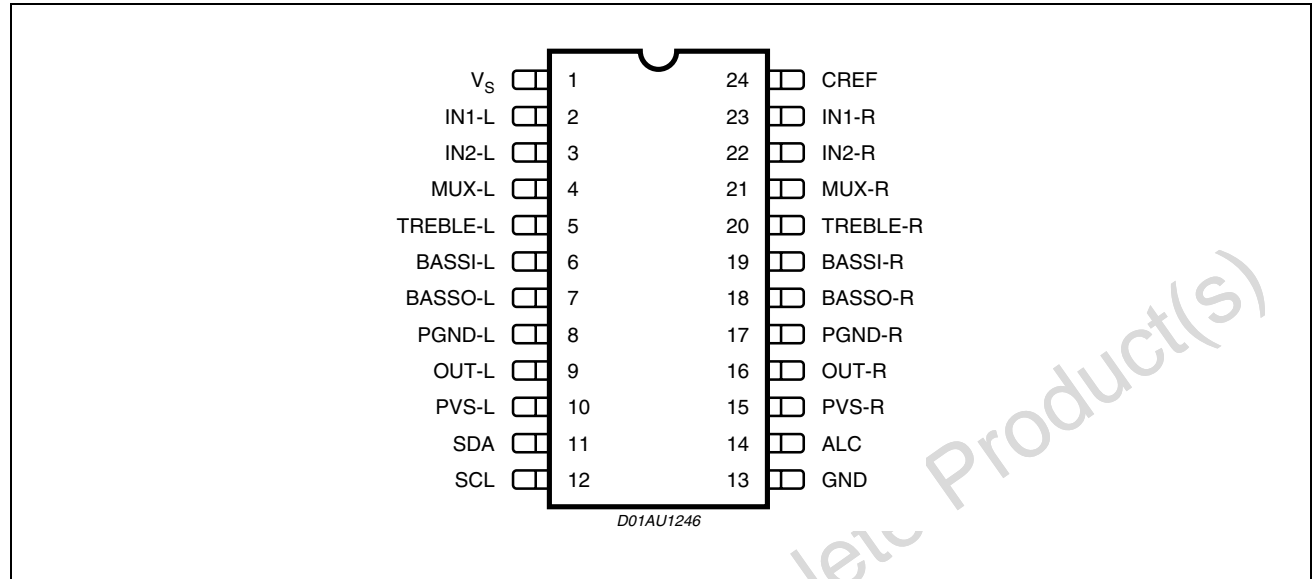

Table 3. THERMAL DATA

Symbol	Parameter	Value	Unit
R _{th j-pin}	Thermal Resistance Junction-pins	85	°C/W

Table 4. QUICK REFERENCE DATA

Symbol	Parameter	Min.	Typ.	Max.	Unit
V _S	Supply Voltage	1.8	2.4	5.0	V
V _{ps}	Power Supply Voltage	1.5	2.4	5.0	V
P _{omax}	Maximum output power THD 10%	5	10		mW
THD	Total Harmonic Distortion V = 0.1Vrms f = 1KHz		0.1	0.5	%
	Volume Control (1dB step)	-63		6	dB
	Treble Control	0		12	dB
	Bass Control	0		14	dB
	Mute Attenuation		90		dB

Table 5.

ELECTRICAL CHARACTERISTICS (refer to the test circuit $T_{amb} = 25^{\circ}\text{C}$, $V_S = 2.4\text{V}$, all controls flat ($G = 0\text{dB}$), $f = 1\text{KHz}$, unless otherwise specified)

Symbol	Parameter	Test Condition	Min.	Typ.	Max.	Unit
SUPPLY						
V_S	Supply Voltage		1.8	2.4	5.0	V
V_{PS}	Supply Voltage		1.5	2.4	5.0	V
I_{SQ}	Supply Current pin 1	All circuit stop		40	100	μA
I_{PSQ}	Quiescent Current pin10 + pin15	Headphone Amp. OFF		1	10	μA
I_S		$P_o = 0.5\text{mW} + 0.5\text{mW}$		8		mA
I_{PS}		$P_o = 0.5\text{mW} + 0.5\text{mW}$		15		mA
INPUT STAGE						
R_{IN}	Input Resistance		35	50	65	$\text{K}\Omega$
A_{IN}	Input Attenuation Range		0		6	dB
VOLUME CONTROL						
C_{RANGE}	Control Range		-63		6	dB
A_{MAX}	Max. Attenuation		61	63	65	dB
A_{STEP}	Step Resolution		0.5	1	1.5	dB
G_{MAX}	Max. Gain			6		dB
G_{step}	Step Resolution			2		dB
R_1	Muxout Load Resistance			10		$\text{K}\Omega$
BASS CONTROL						
G_b	Control Range	Max. Boost/on		14		dB
R_B	Internal Feedback Resistance		75.6	100.8	126	$\text{K}\Omega$
TREBLE CONTROL						
G_t	Control Range	Max. Boost		12		dB
R_t	Internal Resistance			25		$\text{K}\Omega$
HEADPHONE OUTPUTS						
G_{out}	Output Gain			0		dB
P_{omax}	Max Output Power	THD = 10%	5	10		mW
GENERAL						
E_{NO}	Output Noise	All gains = 0dB Output Muted BW = 20Hz to 20KHz flat		5 10		μV μV
THD	Distortion	$A_v = 0$, $V_{in} = 0.1V_{rms}$		0.1	0.5	%
S_C	Channel Separation Left/Right			50		dB
RR1	Ripple Rejection	V_S , $f = 100\text{Hz}$		-70		dB
RR2	Ripple Rejection	PVS, $f = 100\text{Hz}$		-75		dB
	Total Tracking Error			0	1	dB
BUS INPUTS						
V_{IL}	Input Low Voltage				0.5	V
V_{IH}	Input High Voltage		1.9			V
I_{IN}	Input Current	$V_{IN} = 0.4\text{V}$	-5		5	μA
V_O	Output Voltage (ACK)	$I_O = 1.6\text{mA}$			0.4	V

Note: 1. BASS and TREBLE response: The center frequency and the response quality can be chosen by the external circuitry.

3 DATA BYTES

Address = (HEX) 10001000

3.1 FUNCTION SELECTION:

The first byte (subaddress)

Table 6.

MSB							LSB		SUBADDRESS
D7	D6	D5	D4	D3	D2	D1	D0		
X	X	X	B	0	0	0	0	VOLUME	
X	X	X	B	0	0	0	1	TREBLE & BASS	
X	X	X	B	0	0	1	0	INPUT & MUTE	
X	X	X	B	0	0	1	1	STAND-BY & OTHERS	
X	X	X	B	0	1	0	0	BASS ALC1	
X	X	X	B	0	1	0	1	BASS ALC2	

B = 1 incremental bus; active

B = 0 no incremental bus

;X = indifferent 0,1

Table 7. VOLUME

MSB							LSB		VOLUME
D7	D6	D5	D4	D3	D2	D1	D0	GAIN	
						0	0	6	
						0	1	4	
						1	0	2	
						1	1	0	
1 dB STEPS									
			0	0	0			0	
			0	0	1			-1	
			0	1	0			-2	
			0	1	1			-3	
			1	0	0			-4	
			1	0	1			-5	
			1	1	0			-6	
			1	1	1			-7	
8 dB STEPS									
0	0	0						0	
0	0	1						-8	
0	1	0						-16	
0	1	1						-24	
1	0	0						-32	
1	0	1						-40	
1	1	0						-48	
1	1	1						-56	

VOLUME : +6 x -63dB

Table 8. TREBLE & BASS

MSB							LSB		
D7	D6	D5	D4	D3	D2	D1	D0		
								TREBLE	
						0	0	12dB	
						0	1	8dB	
						1	0	4dB	
						1	1	0dB	
								BASS	
			0	0	0			14dB	
			0	0	1			12dB	
			0	1	0			10dB	
			0	1	1			8dB	
			1	0	0			6dB	
			1	0	1			4dB	
			1	1	0			2dB	
			1	1	1			0dB	
								BASS ALC	
		0						ALC: VOLUME mode	
		1						ALC: BASS mode	
	1							ALC: fc shift	
	0							ALC: fc nonshift	
1								ALC: feedback gain x2	
0								ALC: feedback gain x 1	

Table 9. INPUT SELECT & MUTE

MSB							LSB		
D7	D6	D5	D4	D3	D2	D1	D0	INPUT SELECT	
						0	0	IN1 (0dB)	
						0	1	IN1 (-6dB)	
						1	0	IN2 (0dB)	
						1	1	IN2 (-6dB)	
								MUTE	
					1			Input Mute ON	
					0			Input Mute OFF	
				1				Output SoftMute ON	
				0				Output SoftMute OFF	
			1					Output Mute ON	
			0					Output Mute OFF	
								HEADPHONE AMP. ST-BY	
		1						Headphone Amp. OFF	
		0						Headphone Amp. ON	

Table 10. STAND_BY & OTHERS

MSB							LSB	
D7	D6	D5	D4	D3	D2	D1	D0	
								STAND-BY
							1	ALL Circuits Stop
							0	ALL Circuits Work
								SOFT MUTE CAPACITOR
						1		Independent Capacitor
						0		Share ALC Capacitor
								REFERENCE LEVEL
						1		adaptive: (VDD-0.7)/2
			0	0	0			1.10V
			0	1	0			0.85V
			1	0	0			0.55V
			1	1	0			0.45V
								ZEROCROSS MODE
		1						ON
		0						OFF
	1							Zerocross Detect Point: Volume
	0							Zerocross Detect Point: Bass
								CREF STAND-BY
1								CREF Circuit Stop
0								CREF Circuit Work

Table 11. BASS ALC1

MSB							LSB	
D7	D6	D5	D4	D3	D2	D1	D0	BASS ALC
								ALC MODE
							1	ON
							0	OFF
								DETECTOR
						1		ON
						0		OFF
								RELEASE CURRENT CIRCUIT
					1			ON
					0			OFF
								ATTACK TIME RESISTOR
			0	0				12.5K Ω
			0	1				25K Ω
			1	0				50K Ω
			1	1				100K Ω
								THRESHOLD
	0	0						THRESHOLD1
	0	1						THRESHOLD2
	1	0						THRESHOLD3
	1	1						THRESHOLD4

Table 12. BASS ALC2

MSB							LSB	
D7	D6	D5	D4	D3	D2	D1	D0	BASS ALC
								ALC FULL FEEDBACK CURR.
							1	ON
							0	OFF
								BIG RELEASE CURRENT
						1		ON
						0		OFF

Figure 4. Typical Application Circuit (SSO24)

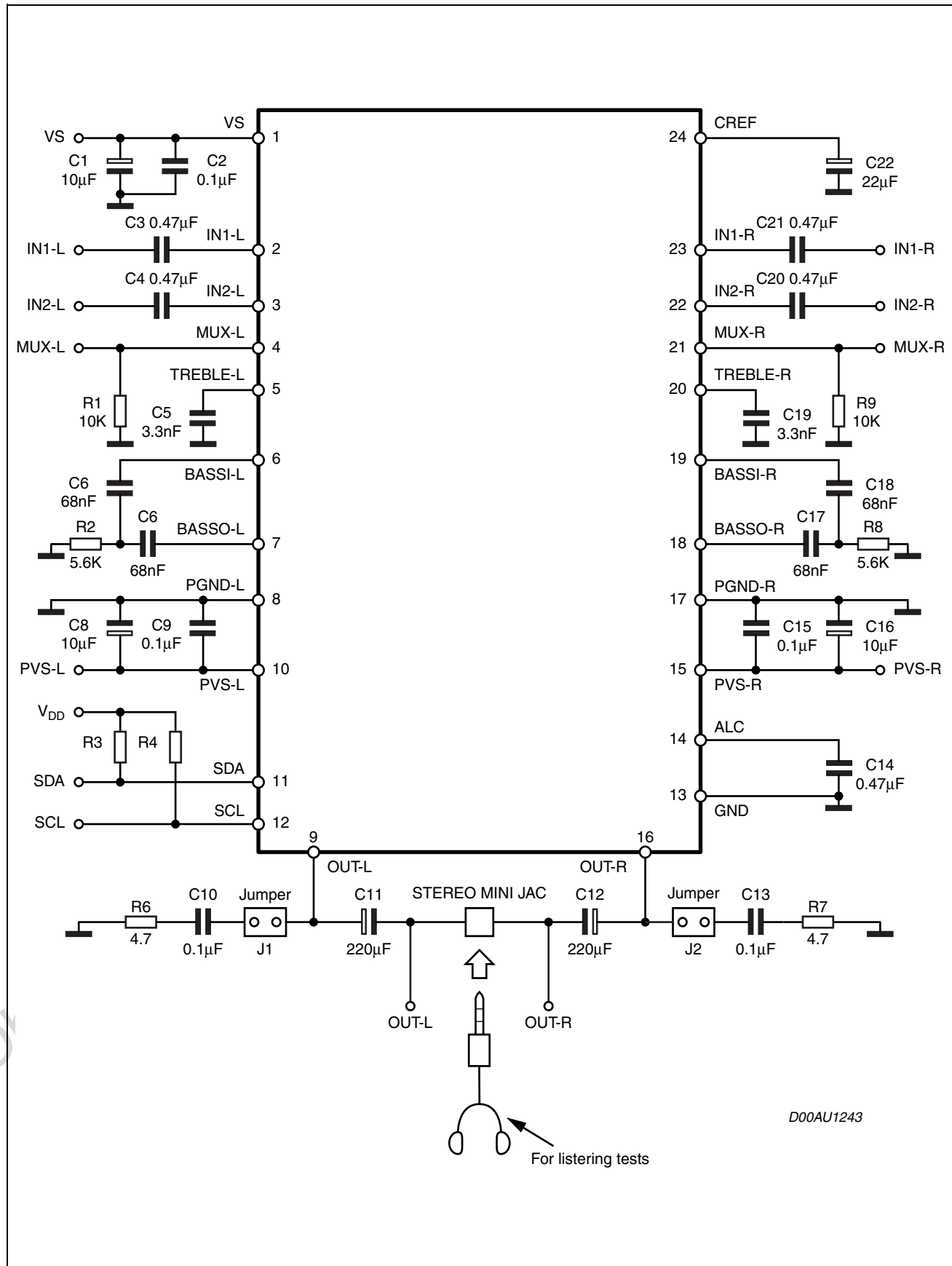

Figure 5. THD+Noise vs Amplitude @ V_{CC} 2.5V,
 R_{load} 16 Ω

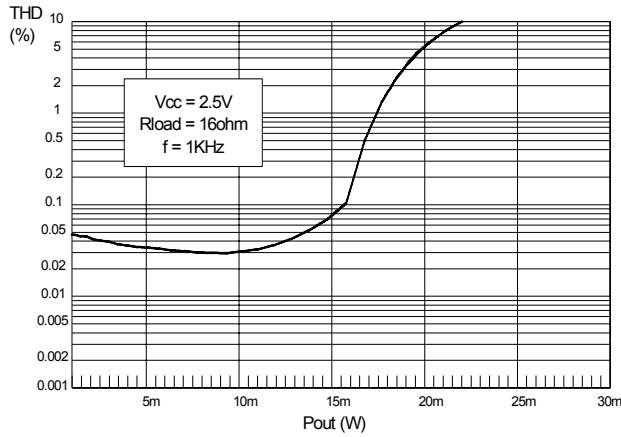

Figure 7. THD+Noise vs Amplitude @ V_{CC} 2.5V,
 R_{load} 32 Ω

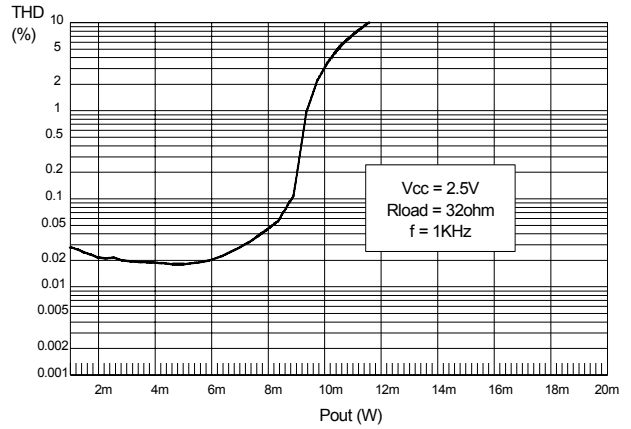

Figure 6. THD+Noise vs Amplitude @ V_{CC} 2.8V,
 R_{load} 16 Ω

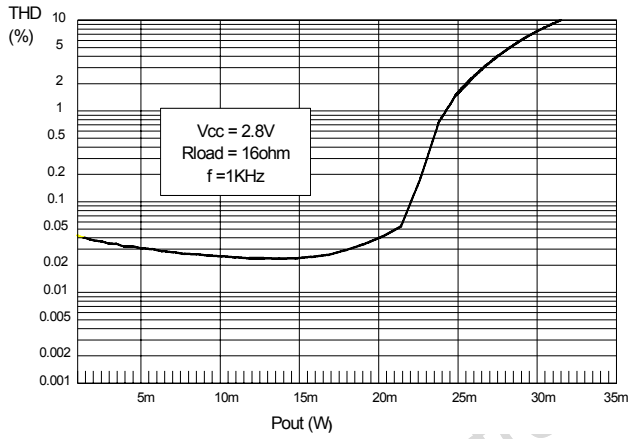

Figure 8. THD+Noise vs Amplitude @ V_{CC} 2.8V,
 R_{load} 32 Ω

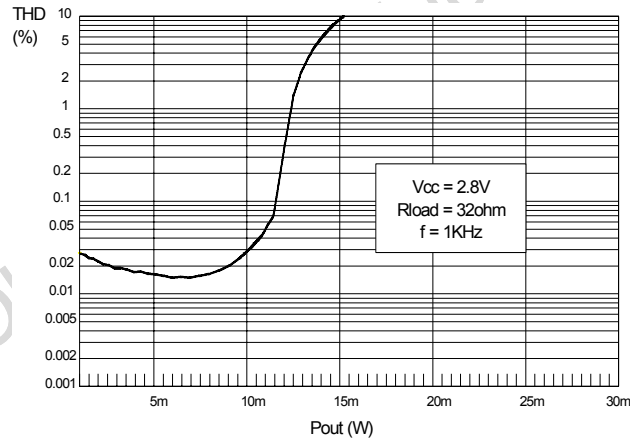

Figure 9. TDA7469 Components Layout

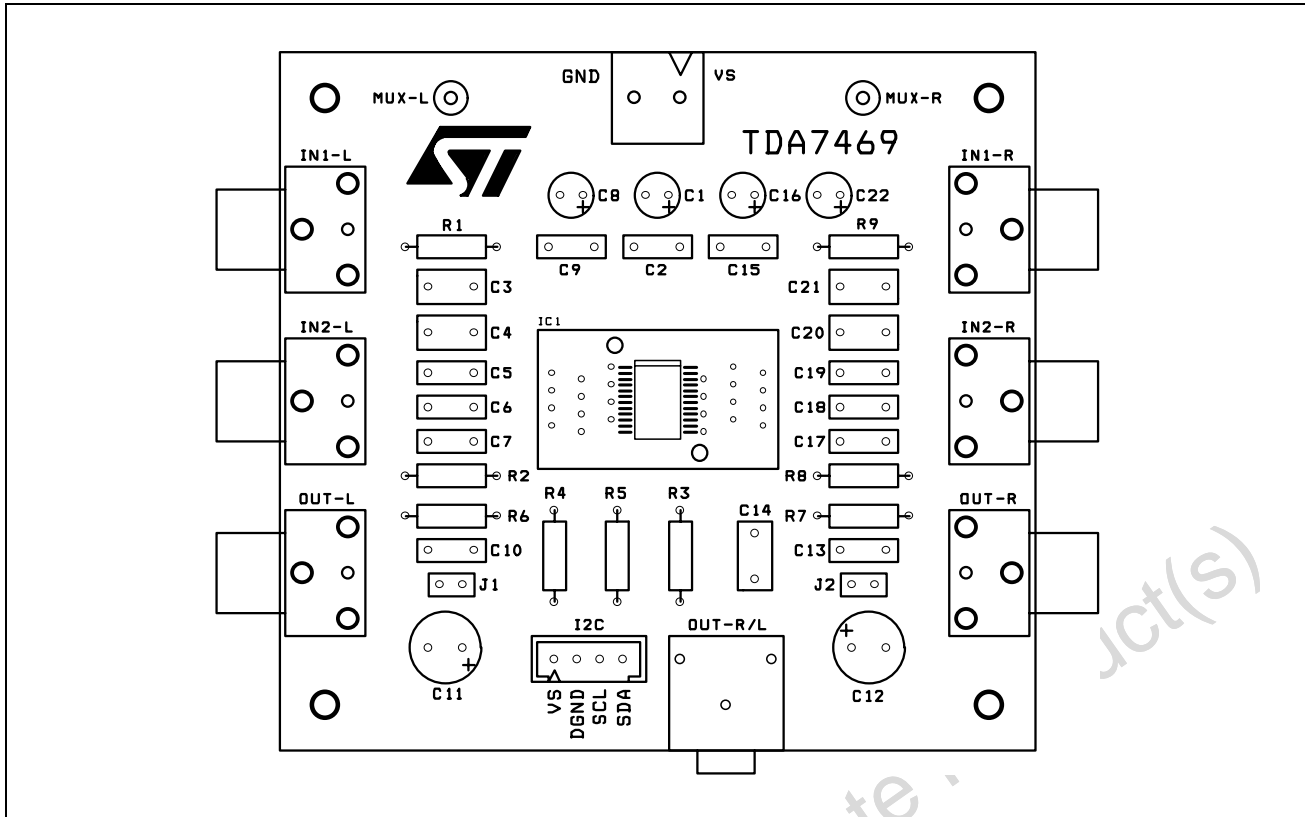

Figure 10. TDA7469 P.C. Board Layout (Top view)

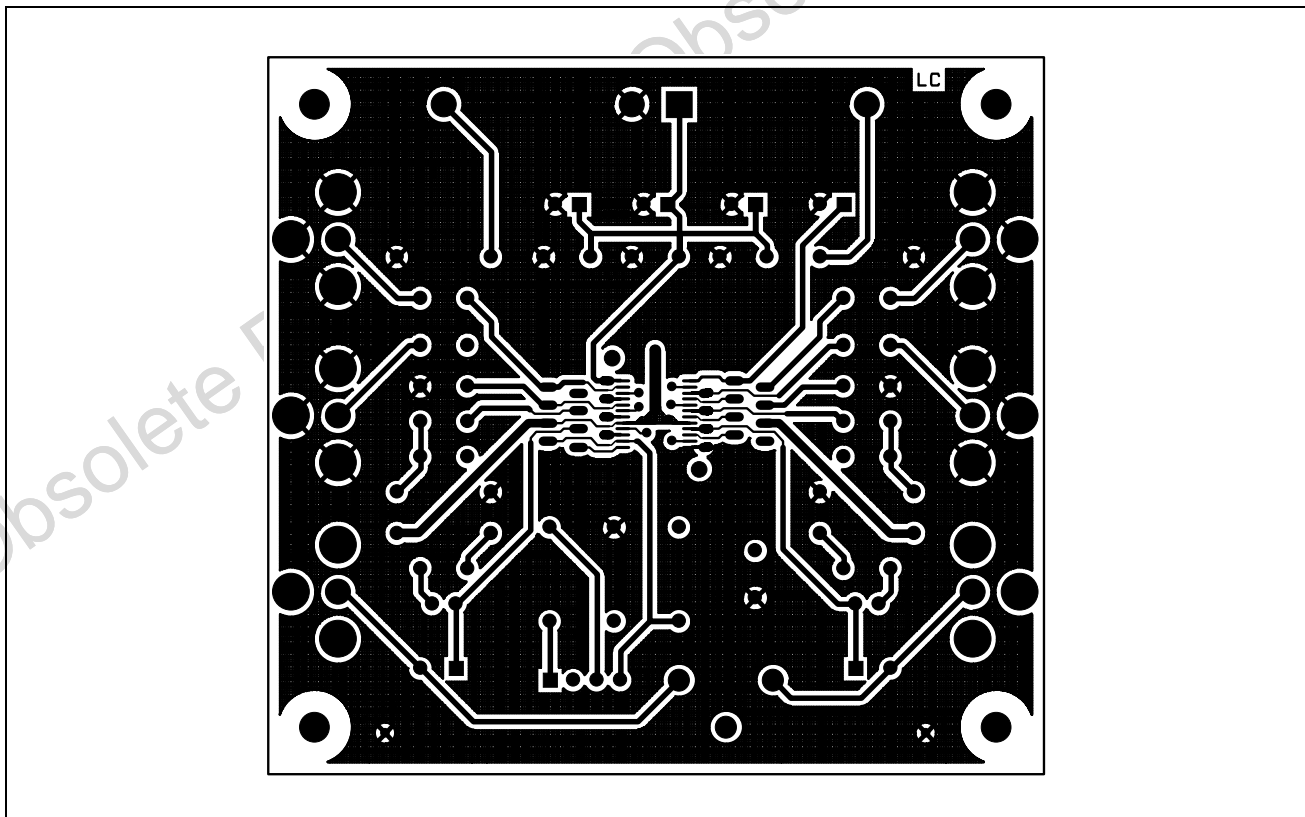
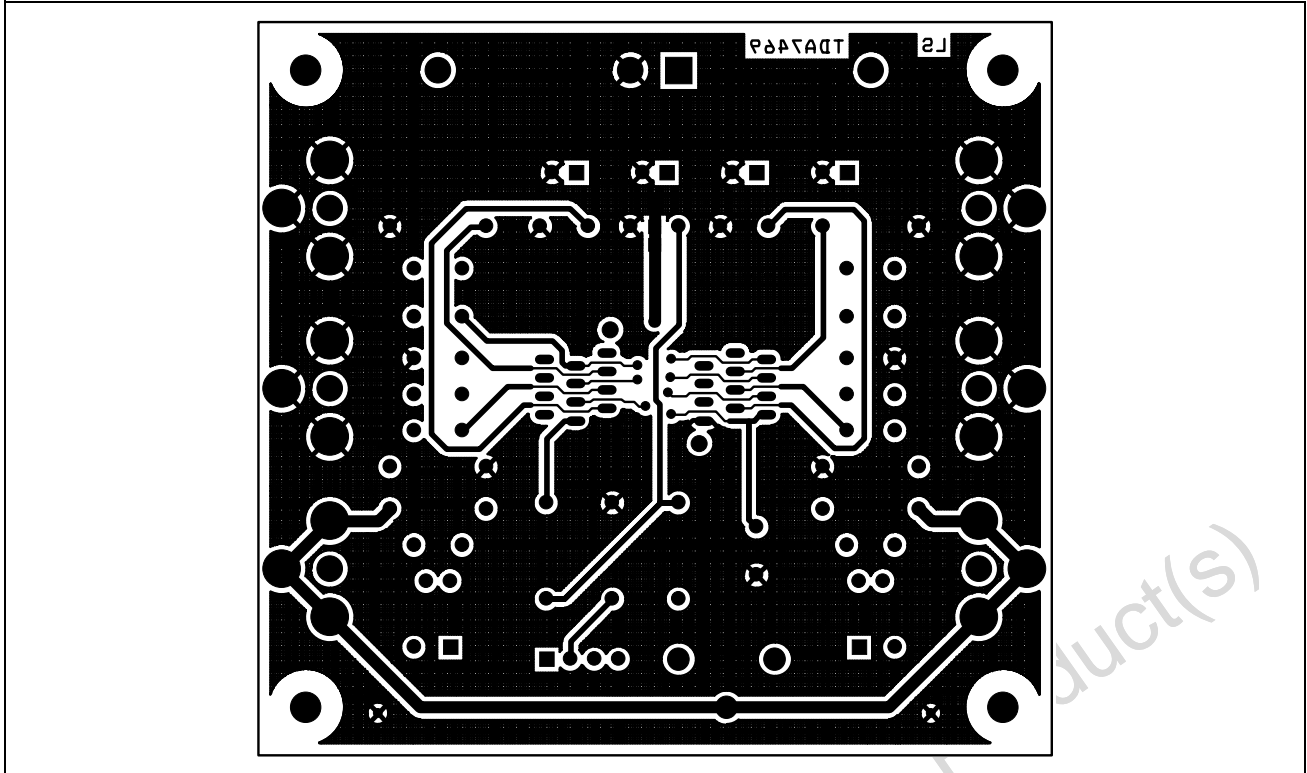

Figure 11. TDA7469 P. C. Board (Backside view)



Obsolete Product(s) - Obsolete Product(s)

Figure 12. SSO24 Mechanical Data & Package Dimensions

DIM.	mm			inch		
	MIN.	TYP.	MAX.	MIN.	TYP.	MAX.
A			2.00			0.079
A1	0.05			0.002		
A2	1.65	1.75	1.85	0.060		0.079
B (2)	0.22		0.38	0.009		0.015
C	0.09		0.25	0.003		0.01
D (1)	7.9	8.2	8.5	0.31	0.32	0.33
E	7.4	7.8	8.2	0.29	0.30	0.32
E1 (1)	5.0	5.3	5.6	0.20	0.21	0.22
e		0.65			0.025	
L	0.55	0.75	0.95	0.022	0.029	0.004
L1		1.25			0.05	
k	0° (min), 4° (typ), 8° (max)					
ddd			0.1			0.004

(1) "D and E1" dimensions do not include mold flash or protrusions, but do include mold mismatch and are measured at datum plane "H". Mold flash or protrusions shall not exceed 0.20mm in total (both side).

(2) "B" dimension does not include dambar protrusion/intrusion.

OUTLINE AND MECHANICAL DATA

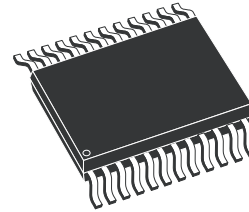

SSO24 Shrink Small Outline Package

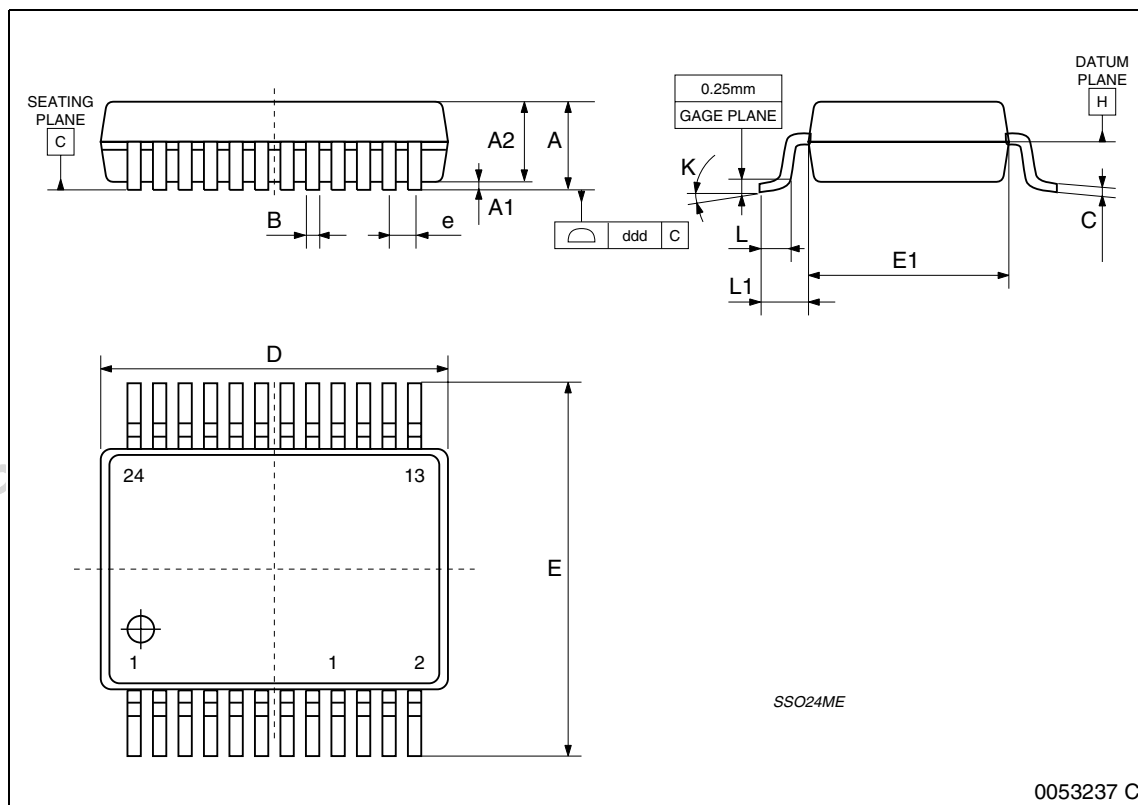

Table 13. Revision History

Date	Revision	Description of Changes
July 2001	1	First Issue
July 2004	2	Removed packages and new style-sheet
15 December 2004	3	Modified value P_{omax} typ. from 8 to 10mW and add. ESD in table 2

Obsolete Product(s) - Obsolete Product(s)

Information furnished is believed to be accurate and reliable. However, STMicroelectronics assumes no responsibility for the consequences of use of such information nor for any infringement of patents or other rights of third parties which may result from its use. No license is granted by implication or otherwise under any patent or patent rights of STMicroelectronics. Specifications mentioned in this publication are subject to change without notice. This publication supersedes and replaces all information previously supplied. STMicroelectronics products are not authorized for use as critical components in life support devices or systems without express written approval of STMicroelectronics.

The ST logo is a registered trademark of STMicroelectronics.
All other names are the property of their respective owners

© 2004 STMicroelectronics - All rights reserved

STMicroelectronics group of companies

Australia - Belgium - Brazil - Canada - China - Czech Republic - Finland - France - Germany - Hong Kong - India - Israel - Italy - Japan - Malaysia - Malta - Morocco - Singapore - Spain - Sweden - Switzerland - United Kingdom - United States of America

www.st.com

