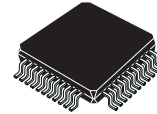




## CARRADIO SIGNAL PROCESSOR

- 3 STEREO INPUTS
- 1 PSEUDO DIFFERENTIAL STEREO INPUT
- VOLUME CONTROL
- 7 BAND EQUALIZER FILTER CONTROL
- HIGH PASS FILTER FOR SUBWOOFER APPLICATION
- DIRECTMUTEANDSOFTMUTE
- 4 INDEPENDENT SPEAKER OUTPUTS
- SOFT STEP SPEAKER CONTROL
- SUBWOOFER OUTPUT WITH SOFT STEP
- 7 BAND SPECTRUM ANALYZER
- FULL MIXING CAPABILITY
- HPF2 WITH ZEROCROSS
- I<sup>2</sup>C-BUS INTERFACE

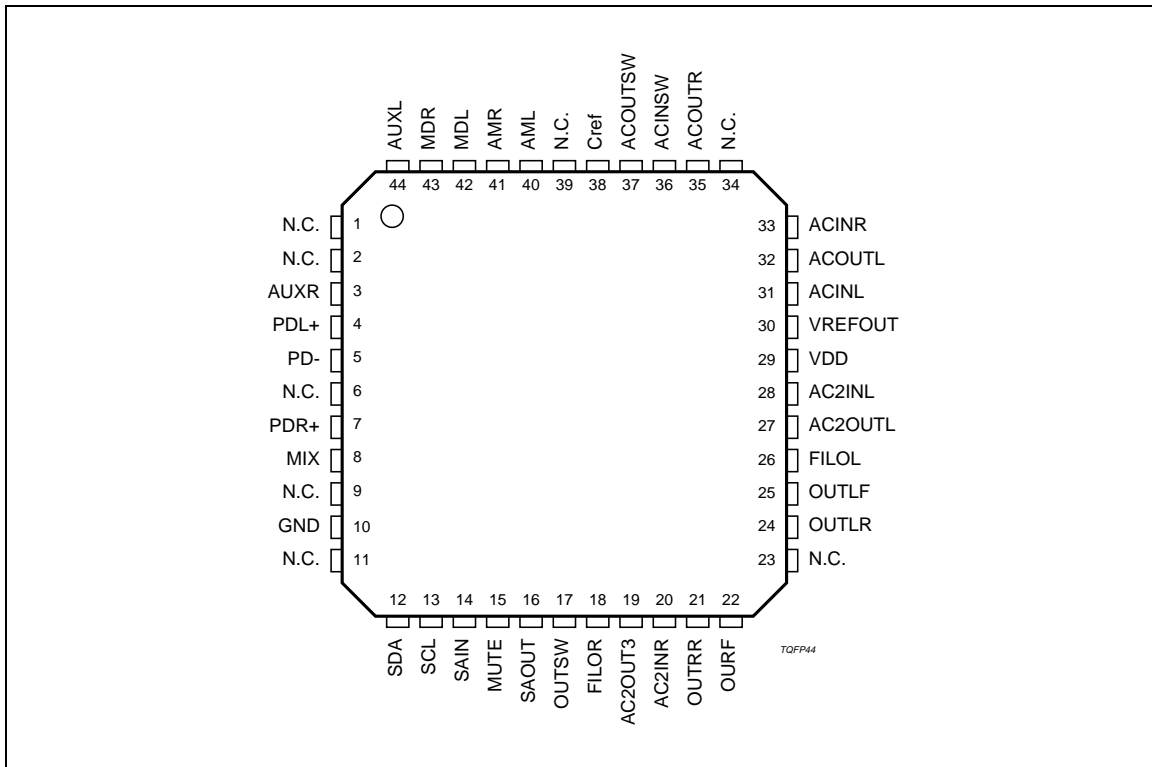


**TQFP44**  
**ORDERING NUMBER: TDA7416**

### DESCRIPTION

The device includes a high performance audioprocessor with 7 bands equalizer and spectrum analyzer. The digital control allows a programming in a wide range of all the filter characteristics.

### PIN CONNECTION (Top view)



## TDA7416

---

### SUPPLY

Symbol	Parameter	Test Conditions	Min.	Typ.	Max.	Unit
V <sub>S</sub>	Supply Voltage		7.5	9	10	V
I <sub>S</sub>	Supply Current	V <sub>S</sub> = 9V	35	45	55	mA
SVRR	Ripple Rejection @ 1kHz	Audioprocessor (all Filters flat)		60		dB

### THERMAL DATA

Symbol	Description	Value	Unit
R <sub>th j-pins</sub>	Thermal Resistance Junction-pins max	65	°C/W

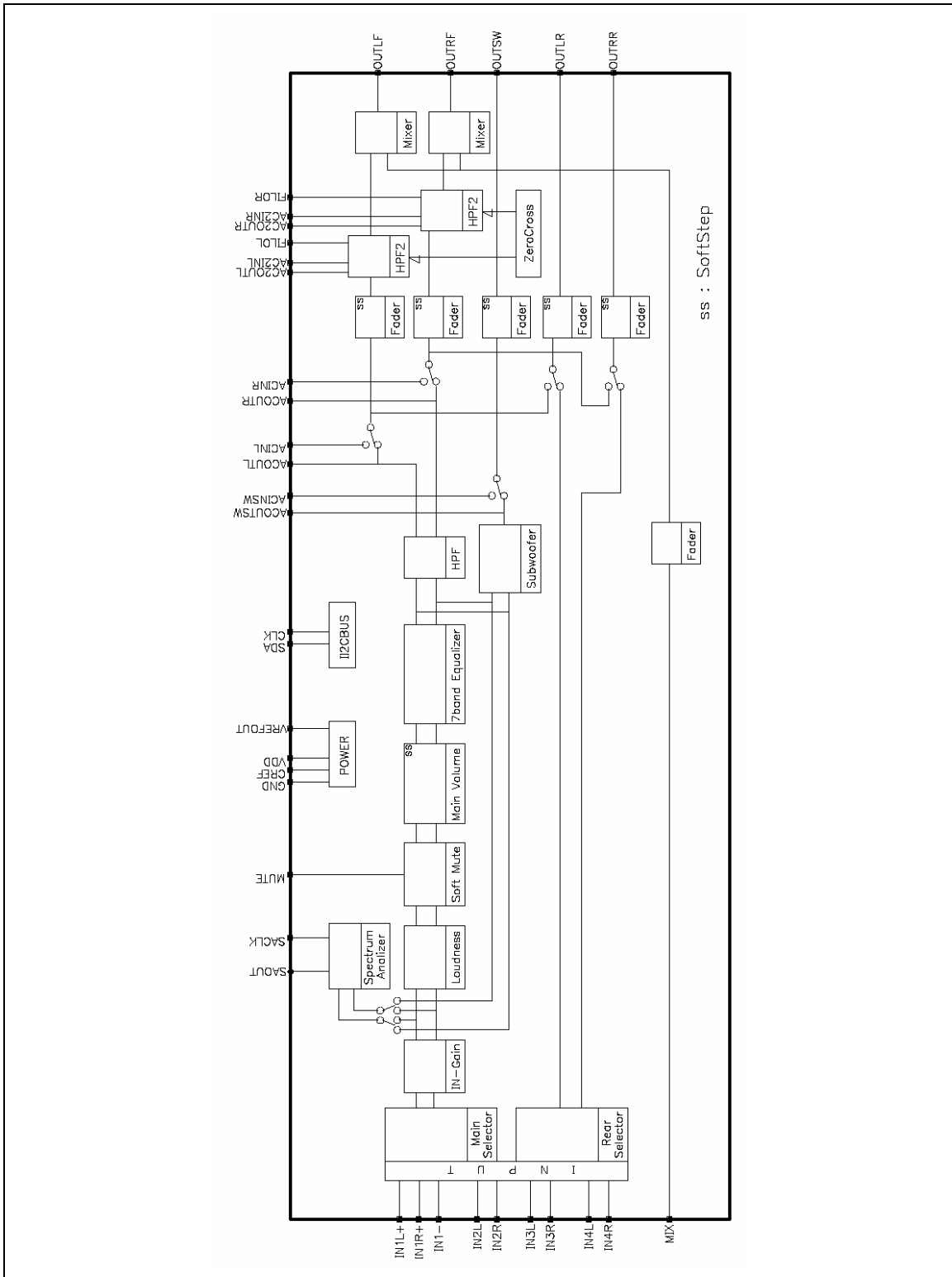
### ABSOLUTE MAXIMUM RATINGS

Symbol	Parameter	Value	Unit
V <sub>S</sub>	Operating Supply Voltage	10.5	V
T <sub>amb</sub>	Operating Temperature Range	-40 to 85	°C
T <sub>stg</sub>	Storage Temperature Range	-55 to +150	°C

### ESD:

All pins are protected against ESD according to the MIL883 standard.

BLOCK DIAGRAM



### FEATURES

#### Input multiplexer

- 1 pseudo differential CDC stereo input, programmable as single-ended input
- 3 single-ended stereo inputs
- Input gain adjust 0 to 15dB with 1dB steps
- direct mute
- internal offset-cancellation (autozero)

#### Mixing stage

- mixable mix input to Front speaker outputs
- Input controls +15 to -79dB with 1dB steps
- direct mute

#### Loudness

- programmable center frequency and filter slope
- 19dB with 1dB steps
- selectable flat-mode (constant attenuation)

#### Volume

- +32 to -79.5dB with 0.5dB step resolution
- soft-step control with programmable blend times
- 100dB range

#### Equalizer

- seven bands
- 2nd order frequency response
- center frequency programmable for lowest and highest filter
- programmable quality factor in four steps for each filter
- -15 to 15dB range with 1dB resolution

#### Spectrum analyzer

- seven bandpass filters
- 2nd order frequency response
- programmable quality factor for different visual appearance
- analog output
- controlled by external serial clock

#### High pass

- 2nd order butterworth highpass with programmable cut-off frequency
- selectable flat-mode

#### Speaker

- 4 independent soft step speaker controls, +15 to -79dB with 1dB steps
- mute
- 4 independent programmable mix inputs with 50% mixing ratio

#### Subwoofer

- single-ended monaural output
- independent soft step level control +15 to -79dB with 1dB steps

#### Mute functions

- direct mute
- digitally controlled SoftMute with 3 programmable mute-times

#### Effect

- Gain effect or high pass effect fixed external components

**Table 1. ELECTRICAL CHARACTERISTICS**(V<sub>S</sub>=9V; T<sub>amb</sub>=25°C; R<sub>L</sub>=10kΩ; all gains=0dB; f=1kHz; unless otherwise specified)

Symbol	Parameter	Test Condition	Min.	Typ.	Max.	Unit
<b>INPUT SELECTOR</b>						
R <sub>in</sub>	Input Resistance	all single ended Inputs	70	100	130	kΩ
V <sub>CL</sub>	Clipping Level		1.8	2.2		V <sub>RMS</sub>
S <sub>IN</sub>	Input Separation		80	100		dB
G <sub>IN MIN</sub>	Min. Input Gain		-1	0	1	dB
G <sub>IN MAX</sub>	Max. Input Gain		13	15	17	dB
G <sub>STEP</sub>	Step Resolution		0.5	1	1.5	dB
V <sub>DC</sub>	DC Steps	Adjacent Gain Steps	-5	1	5	mV
		G <sub>MIN</sub> to G <sub>MAX</sub>	-10	1	10	mV
V <sub>offset</sub>	Remaining offset with Autozero			0.5		mV
<b>DIFFERENTIAL STEREO INPUTS</b>						
R <sub>in</sub>	Input Resistance (see Fig. 1)	Differential	70	100	130	kΩ
CMRR	Common Mode Rejection Ratio	V <sub>CM</sub> = 1V <sub>RMS</sub> @ 1kHz	46	70		dB
		V <sub>CM</sub> = 1V <sub>RMS</sub> @ 10kHz	46	60		dB
e <sub>NO</sub>	Output-Noise @ Speaker-Outputs	20Hz - 20kHz, flat; all stages 0dB		11		μV
<b>MIXING CONTROL</b>						
M <sub>LEVEL</sub>	Mixing Ratio	Main / Mix-Source		-6/-6		dB
G <sub>MAX</sub>	Max. Gain		13	15	17	dB
A <sub>MAX</sub>	Max. Attenuation		-83	-79	-75	dB
A <sub>STEP</sub>	Attenuation Step		0.5	1	1.5	dB
<b>LOUDNESS CONTROL</b>						
A <sub>STEP</sub>	Step Resolution		0.5	1	1.5	dB
A <sub>MAX</sub>	Max. Attenuation		-21	-19	-17	dB
f <sub>Peak</sub>	Peak Frequency	f <sub>P1</sub>	180	200	220	Hz
		f <sub>P2</sub>	360	400	440	Hz
		f <sub>P3</sub>	540	600	660	Hz
		f <sub>P4</sub>	720	800	880	Hz
<b>VOLUME CONTROL</b>						
G <sub>MAX</sub>	Max. Gain		18	20	22	dB
A <sub>MAX</sub>	Max. Attenuation		-83	-79	-75	dB
A <sub>STEP</sub>	Step Resolution		0	0.5	1	dB
E <sub>A</sub>	Attenuation Set Error	G = -20 to +20dB	-0.75	0	+0.75	dB
		G = -80 to -20dB	-4	0	3	dB
E <sub>T</sub>	Tracking Error				2	dB
V <sub>DC</sub>	DC Steps	Adjacent Attenuation Steps		0.1	3	mV
		From 0dB to G <sub>MIN</sub>		0.5	5	mV
<b>SOFT MUTE</b>						
A <sub>MUTE</sub>	Mute Attenuation		80	100		dB

**Table 1. ELECTRICAL CHARACTERISTICS** (continued)

( $V_S=9V$ ;  $T_{amb}=25^{\circ}C$ ;  $R_L=10k\Omega$ ; all gains=0dB;  $f=1kHz$ ; unless otherwise specified)

Symbol	Parameter	Test Condition	Min.	Typ.	Max.	Unit
$T_D$	Delay Time	T1		0.48	1	ms
		T2		0.96	2	ms
		T3	70	123	170	ms
$V_{TH\ low}$	Low Threshold for SM-Pin <sup>1)</sup>			1	V	
$V_{TH\ high}$	High Threshold for SM - Pin		2.5		V	
RPU	Internal pull-up resistor		32	45	58	k $\Omega$
$V_{PU}$	Internal pull-up Voltage			3.3		V

**EQUALIZER CONTROL**

$C_{RANGE}$	Control Range		$\pm 14$	$\pm 15$	$\pm 16$	dB
$A_{STEP}$	Step Resolution		0.5	1	1.5	dB
$f_{C1}$	Center Frequency Band 1	$f_{C1a}$	55	62	69	Hz
		$f_{C1b}$	90	100	110	Hz
$f_{C2}$	Center Frequency Band 2	$f_{C2}$	141	157	173	Hz
$f_{C3}$	Center Frequency Band 3	$f_{C3}$	365	396	437	Hz
$f_{C4}$	Center Frequency Band 4	$f_{C4}$	0.9	1	1.1	kHz
$f_{C5}$	Center Frequency Band 5	$f_{C5}$	2.25	2.51	2.76	kHz
$f_{C6}$	Center Frequency Band 6	$f_{C6a}$	3.6	4	4.4	kHz
		$f_{C6b}$	5.70	6.34	6.98	kHz
$f_{C7}$	Center Frequency Band 7	$f_{C7a}$	13.5	15	16.5	kHz
		$f_{C7b}$	14.4	16	17.6	kHz
Q	Quality Factor	$Q_1$	0.9	1	1.1	
		$Q_2$	1.26	1.4	1.54	
		$Q_3$	1.62	1.8	1.98	
		$Q_4$	1.98	2.2	2.44	
$DC_{GAIN}$	DC-gain, Band 1	DC = off	-1	0	+1	dB
		DC = on, 15dB boost		4		dB

**SPECTRUM ANALYZER CONTROL**

$V_{SAOut}$	Output Voltage Range		0		3.3	V
$f_{C1}$	Center Frequency Band 1	$f_{C1}$	55	62	69	Hz
$f_{C2}$	Center Frequency Band 2	$f_{C2}$	141	157	173	Hz
$f_{C3}$	Center Frequency Band 3	$f_{C3}$	356	396	436	Hz
$f_{C4}$	Center Frequency Band 4	$f_{C4}$	0.9	1	1.1	kHz
$f_{C5}$	Center Frequency Band 5	$f_{C5}$	2.26	2.51	2.76	kHz
$f_{C6}$	Center Frequency Band 6	$f_{C6}$	5.70	6.34	6.98	kHz
$f_{C7}$	Center Frequency Band 7	$f_{C7}$	14.4	16	17.6	kHz
Q	Quality Factor	$Q_1$	1.62	1.8	1.98	
		$Q_2$	3.15	3.5	3.85	
$f_{SAClk}$	Clock Frequency		1		100	kHz
$t_{SA\ del}$	Analog Output Delay Time		2			$\mu s$

1) The SM-Pin is active low (Mute = 0)

**Table 1. ELECTRICAL CHARACTERISTICS** (continued)(V<sub>S</sub>=9V; T<sub>amb</sub>=25°C; R<sub>L</sub>=10kΩ; all gains=0dB; f=1kHz; unless otherwise specified)

Symbol	Parameter	Test Condition	Min.	Typ.	Max.	Unit
t <sub>repeat</sub>	Spectrum Analyzer Repeat Time		50			ms
t <sub>intres</sub>	Internal Reset Time			3		ms

**HPF2**

V <sub>TH</sub>	Zero Crossing Threshold			±20		mV
E <sub>MAX</sub>	Max. Effect			22		dB
E <sub>MIN</sub>	Min. Effect			4		dB
E <sub>STEP</sub>	Step Resolution		1.5	2	2.5	dB

**SPEAKER ATTENUATORS**

R <sub>in</sub>	Input Impedance		35	50	65	kΩ
G <sub>MAX</sub>	Max. Gain		13	15	17	dB
A <sub>MAX</sub>	Max. Attenuation		-83	-79	-75	dB
A <sub>STEP</sub>	Step Resolution		0.5	1	1.5	dB
A <sub>MUTE</sub>	Output Mute Attenuation		80	90		dB
E <sub>E</sub>	Attenuation Set Error				3	dB
V <sub>DC</sub>	DC Steps	Adjacent Attenuation Steps		0.5	5	mV
M <sub>R</sub>	Mixing Ratio	Signal/Mix <sub>in</sub>		50/50		%

**AUDIO OUTPUTS**

V <sub>CLIP</sub>	Clipping Level	Thd=0.3%	1.8	2.2		V <sub>RMS</sub>
R <sub>L</sub>	Output Load Resistance		2			kΩ
C <sub>L</sub>	Output Load Capacitance				10	nF
R <sub>OUT</sub>	Output Impedance			30	120	Ω
V <sub>DC</sub>	DC Voltage Level		4.3	4.5	4.7	V

**HIGH PASS**

f <sub>HP</sub>	Highpass corner frequency	f <sub>HP1</sub>	81	90	99	Hz
		f <sub>HP2</sub>	122	135	148	Hz
		f <sub>HP3</sub>	162	180	198	Hz
		f <sub>HP4</sub>	194	215	236	Hz

**SUBWOOFER ATTENUATOR**

R <sub>in</sub>	Input Impedance		35	50	65	kΩ
G <sub>MAX</sub>	Max. Gain		14	15	16	dB
A <sub>ATTN</sub>	Max. Attenuation		-83	-79	-75	dB
A <sub>STEP</sub>	Step Resolution		0.5	1	1.5	dB
A <sub>MUTE</sub>	Output Mute Attenuation		80	90		dB
E <sub>E</sub>	Attenuation Set Error				2	dB
V <sub>DC</sub>	DC Steps	Adjacent Attenuation Steps		1	5	mV

**SUBWOOFER Lowpass**

f <sub>LP</sub>	Lowpass corner frequency	f <sub>LP1</sub>	72	80	88	Hz
		f <sub>LP2</sub>	108	120	132	Hz
		f <sub>LP3</sub>	144	160	176	Hz

**Table 1. ELECTRICAL CHARACTERISTICS** (continued)

( $V_S=9V$ ;  $T_{amb}=25^{\circ}C$ ;  $R_L=10k\Omega$ ; all gains=0dB;  $f=1kHz$ ; unless otherwise specified)

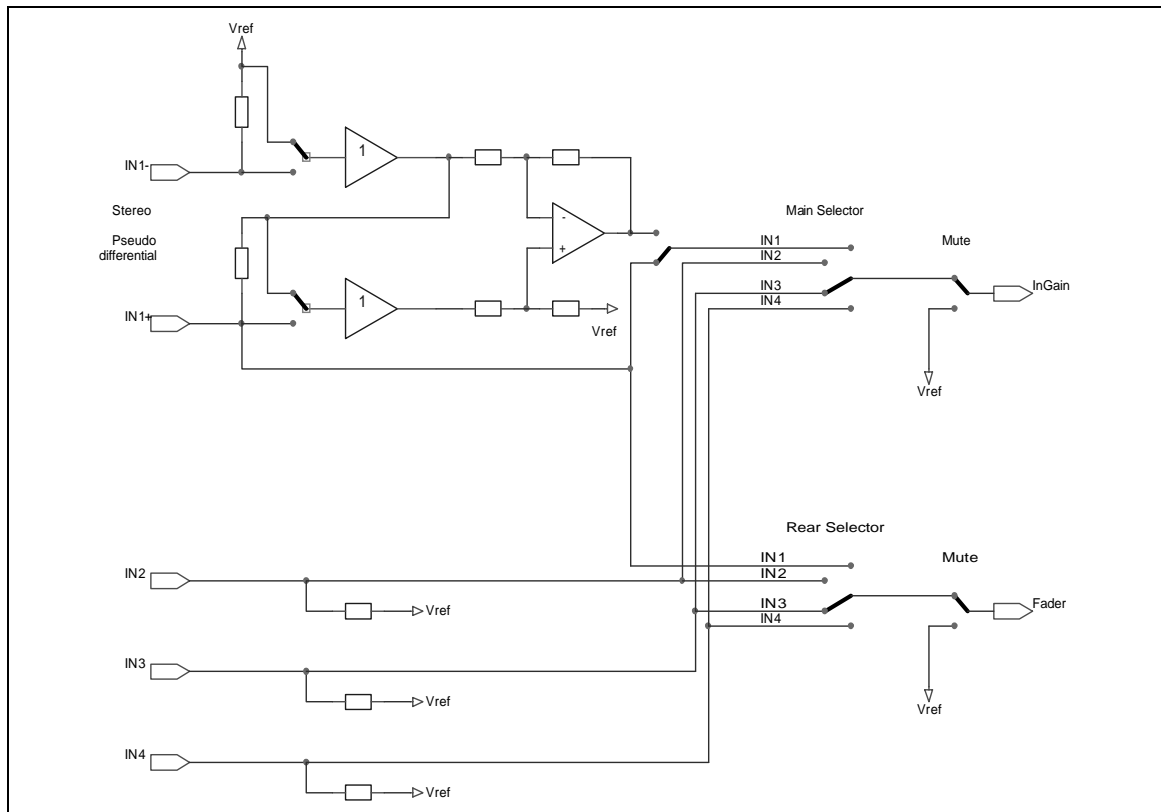
Symbol	Parameter	Test Condition	Min.	Typ.	Max.	Unit
<b>GENERAL</b>						
$e_{NO}$	Output Noise	BW = 20Hz - 20kHz output muted		3	15	$\mu V$
		BW = 20Hz - 20kHz all gains = 0dB single ended inputs		15	20	$\mu V$ $\mu V$
S/N	Signal to Noise Ratio	all gains = 0dB flat; $V_O = 2V_{RMS}$		103		dB
		All EQ-bands at +12dB; Q = 1.0 a-weighted; $V_O = 2.6V_{RMS}$		87		dB
d	distortion	$V_{IN} = 1V_{RMS}$ ; all stages 0dB		0.01	0.1	%
		$V_{OUT} = 1V_{RMS}$ ; Bass & Treble = 12dB		0.05	0.1	%
$S_C$	Channel Separation left/right		80	90		dB

**1 DESCRIPTION OF THE AUDIOPROCESSOR PART**

**1.1 Input stages**

In the basic configuration one pseudo-differential, three single ended stereo are available.

**Figure 1. Input-stages**





### 1.1.1 Pseudo-differential stereo Input (IN1)

The IN1-input is implemented as a buffered pseudo-differential stereo stage with 100k $\Omega$  input-impedance at each input pin. This input is also configurable as single-ended stereo input. The common input-pin, IN1- features a fast charge switch to speed up the charge time of external capacitors.- This switch is released the first time the input-selector data-byte (0) is assessed.

### 1.1.2 Single-ended stereo Inputs

All single ended inputs have an input impedance of 100k $\Omega$ .

## 1.2 AutoZero

The AutoZero allows a reduction of the number of pins as well as external components by canceling any offset generated by or before the In-Gain-stage (Please notice that externally generated offsets, e.g. generated through the leakage current of the coupling capacitors, are not canceled).

The auto-zeroing is started every time the DATA-BYTE 0 is selected and needs max. **0.3ms** for the alignment. To avoid audible clicks the Audioprocessor have to be muted by softmute or hard mute during this time.

### 1.2.1 AutoZero-Remain

In some cases, for example if the  $\mu$ P is executing a refresh cycle of the IIC-Bus-programming, it is not useful to start a new AutoZero-action because no new source is selected and an undesired mute would appear at the out-puts. For such applications the TDA7416 could be switched in the AutoZero-Remain-Mode (Bit 6(I1) of the subaddress-byte). If this bit is set to high, the DATABYTE 0 could be loaded without invoking the AutoZero and the old adjustment-value remains.

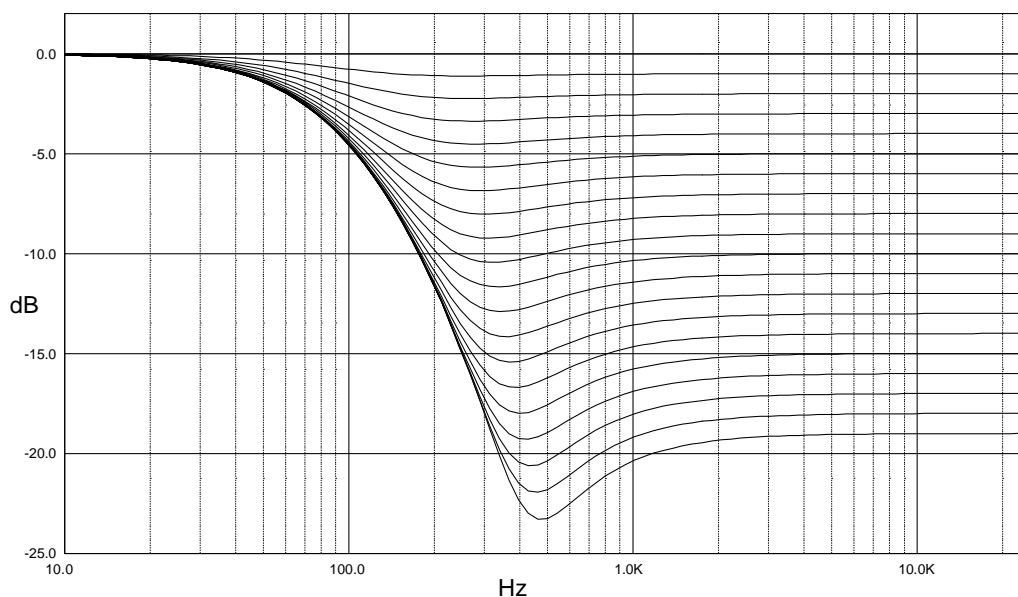
## 1.3 Loudness

There are four parameters programmable in the loudness stage:

### 1.3.1 Attenuation

Figure 2 shows the attenuation as a function of frequency at  $f_p = 400\text{Hz}$

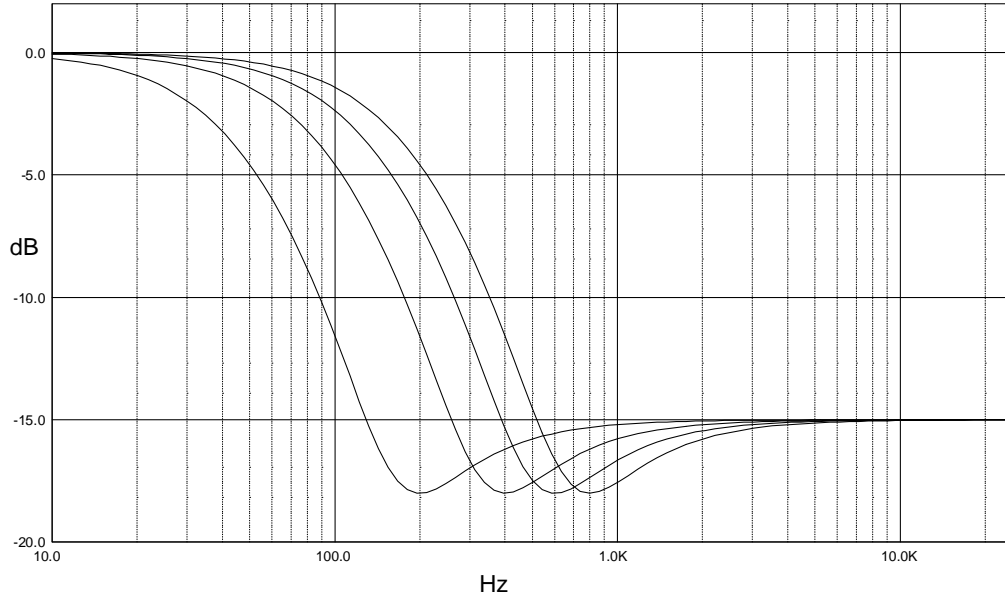
**Figure 2. Loudness Attenuation @  $f_p = 400\text{Hz}$ .**



### 1.3.2 Peak Frequency

Figure 3 shows the four possible peak-frequencies at 200, 400, 600 and 800Hz

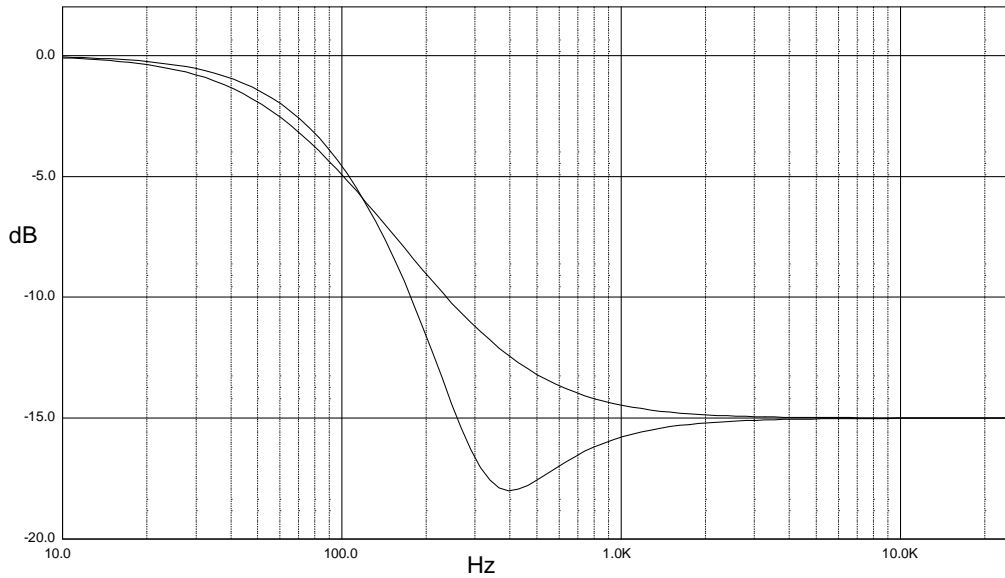
Figure 3. Loudness Center frequencies @ Attn. = 15dB



### 1.3.3 Loudness filter order

Different shapes of 1st and 2nd-Order Loudness

Figure 4. 1st and 2nd Order Loudness @ Attn. = 15dB, fP=400Hz



### 1.3.4 Flat Mode

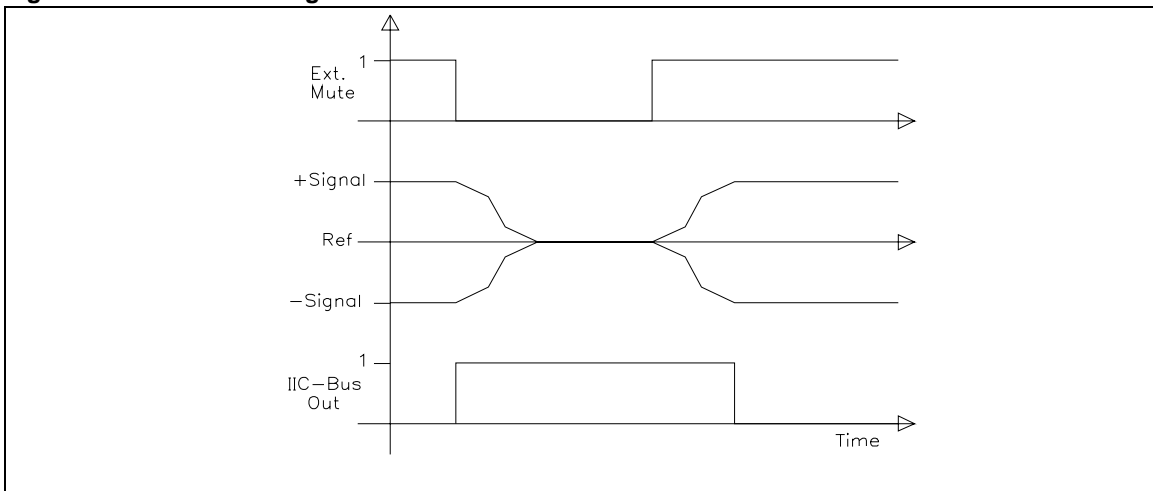
In flat mode the loudness stage works as a 0dB to -19dB attenuator.

#### 1.4 SoftMute

The digitally controlled SoftMute stage allows muting/demuting the signal with a I<sup>2</sup>C-bus programmable slope. The mute process can either be activated by the SoftMute pin or by the I<sup>2</sup>C-bus. This slope is realized in a special S-shaped curve to mute slow in the critical regions (see Figure 5).

For timing purposes the Bit0 of the I<sup>2</sup>C-bus output register is set to 1 from the start of muting until the end of de-muting.

**Figure 5. Soft Mute-Timing**

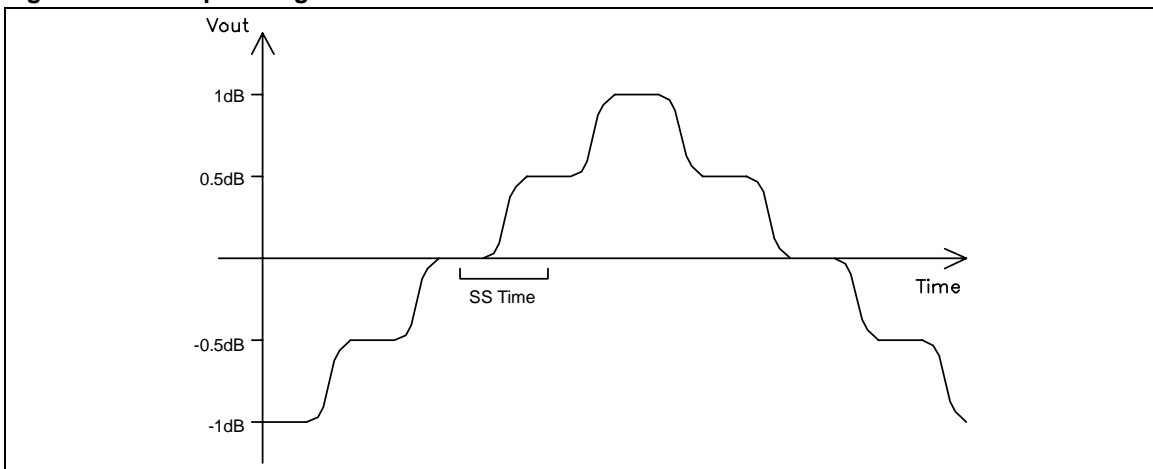


Note: Please notice that a started Mute-action is always terminated and could not be interrupted by a change of the mute -signal.

#### 1.5 SoftStep Volume and Speaker

When the speaker-level is changed audible clicks could appear at the output. The root cause of those clicks could either be a DC-Offset before the speaker-stage or the sudden change of the envelope of the audio signal. With the SoftStep-feature both kinds of clicks could be reduced to a minimum and are no more audible. The blend-time from one step to the next is programmable in four steps.

**Figure 6. SoftStep-Timing for Volume**



Note: For steps more than 0.5dB (Volume) or 1dB (Speaker) the SoftStep mode should be deactivated because it could generate a hard 1dB step during blending.

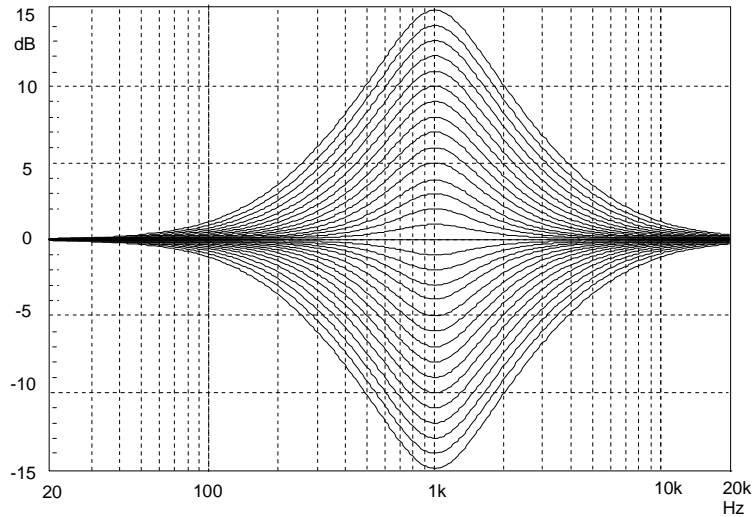
**1.6 Equalizer filter**

There are three parameters programmable in the equalizer filter:

**1.6.1 Attenuation**

Figure 7 shows the boost and cut response as a function of frequency at a center frequency of 1kHz.

**Figure 7. Equalizer filter control @  $f_{Center} = 1kHz$ ,  $Q = 1.0$**

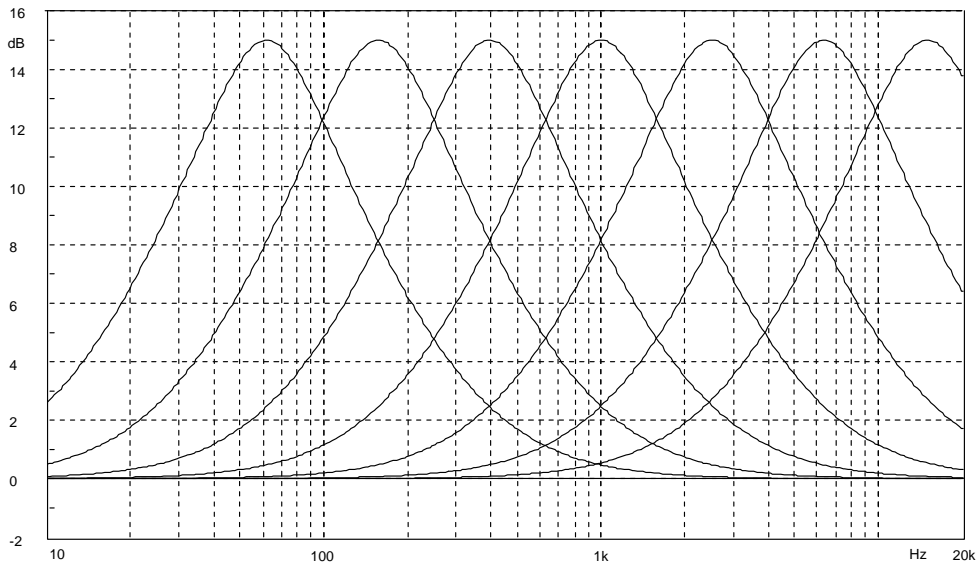


**1.6.2 Center Frequency**

This parameter is programmable in the filter stage 1(62/100Hz), 6(4/6.34kHz) and 7(15/16kHz) only.

Figure 8 shows the center frequencies 62, 156, 396, 1000, 2510, 6340 and 15000Hz of the 7 equalizer filters.

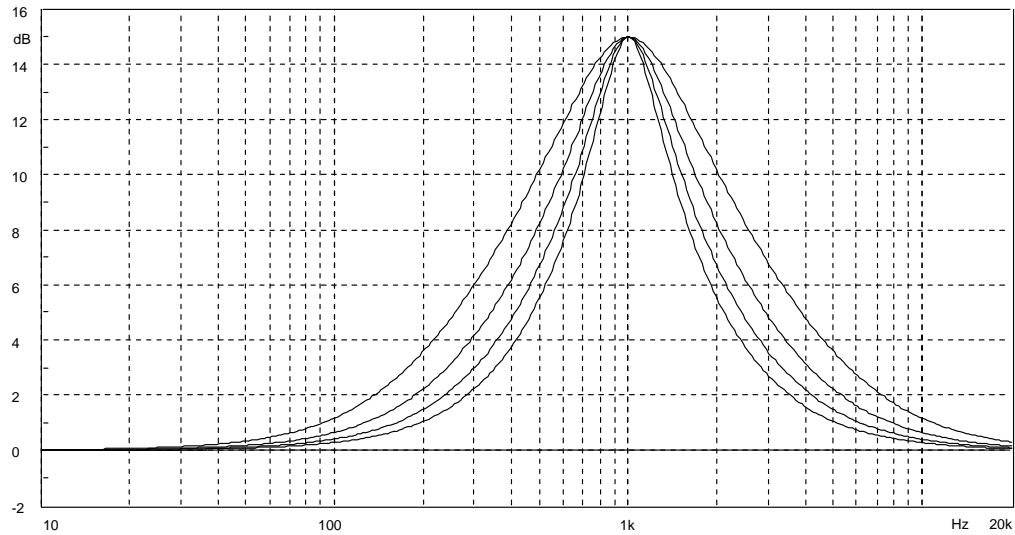
**Figure 8. Center frequencies @ Gain = 15dB,  $Q = 1.0$**



### 1.6.3 Quality Factors

Figure 9 shows the four possible quality factors 1, 1.4, 1.8 and 2.2

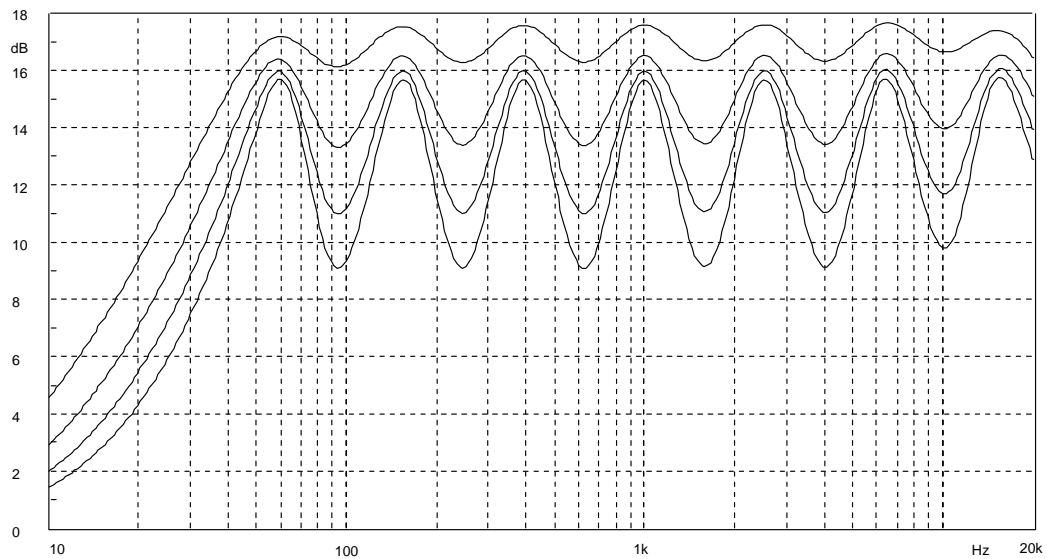
**Figure 9. Quality factors @ boost = 15dB,  $f_{\text{Center}} = 1\text{kHz}$**



### 1.6.4 Superposition of all EQ Filters

Figure 10 shows the superposition of all equalizer filter curves for different quality factors. The gain for all filters is +15dB.

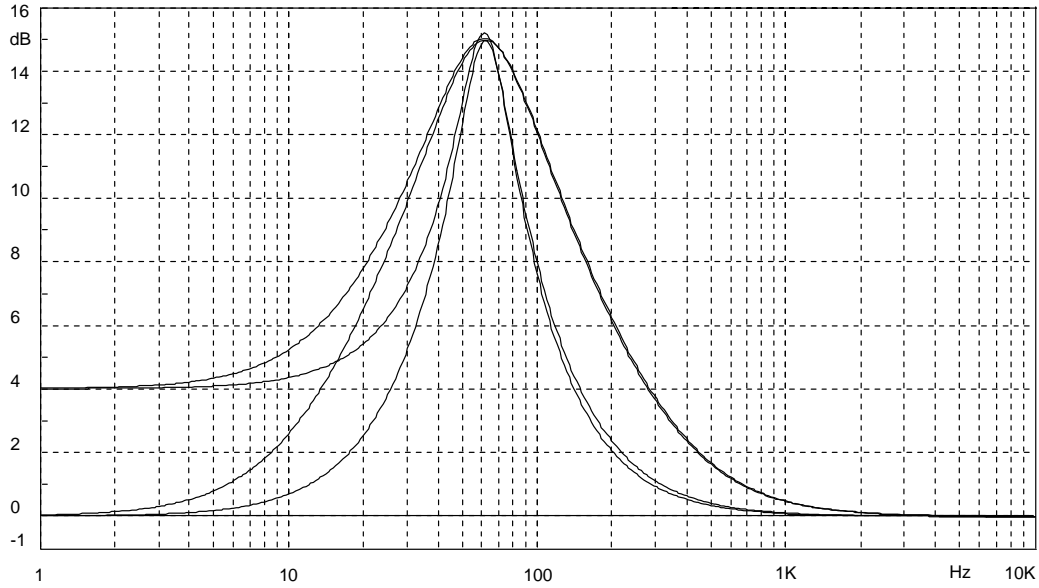
**Figure 10. Superposition of all EQ bands @ boost = 15dB**



**1.6.5 DC-mode of equalizer band 1 (62/100 Hz)**

In this mode, the DC-gain 4dB when set to 15dB boost.

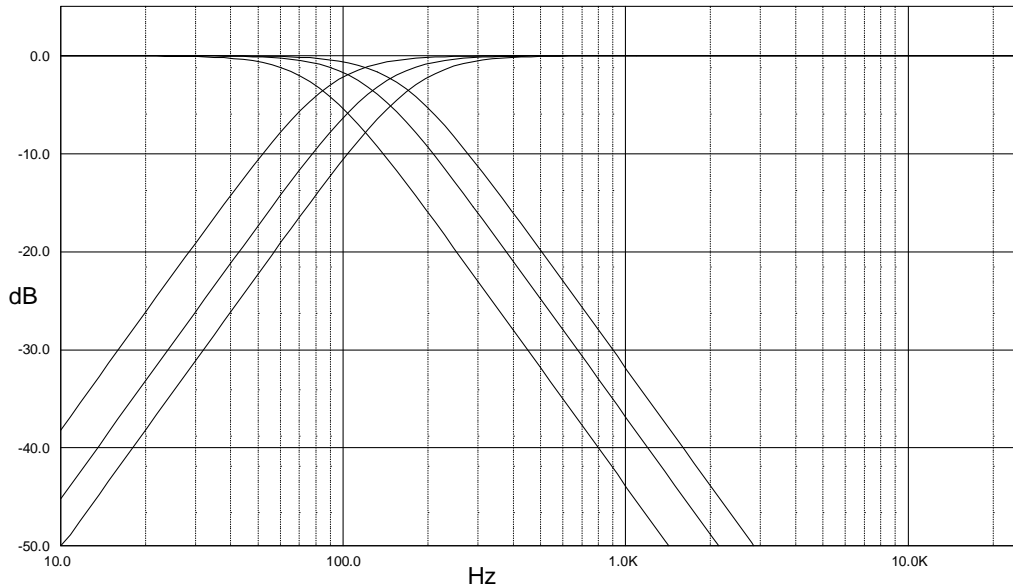
**Figure 11. EQ band1, normal- and DC-mode @ boost = 15 dB,  $f_{Center} = 62$  Hz**



Note: The center frequency, Q, DC-mode and boost/cut can be set fully independently for each filter.

**1.7 Subwoofer Application**

**Figure 12. Subwoofer Application with Lowpass @ 80/120/160Hz and HighPass @ 90/135/180Hz**



Both filters, the lowpass- as well as the highpass-filter, have butterworth characteristic so that their cut-off frequencies are not equal but shifted by the factor 1.125 to get a flat frequency response.

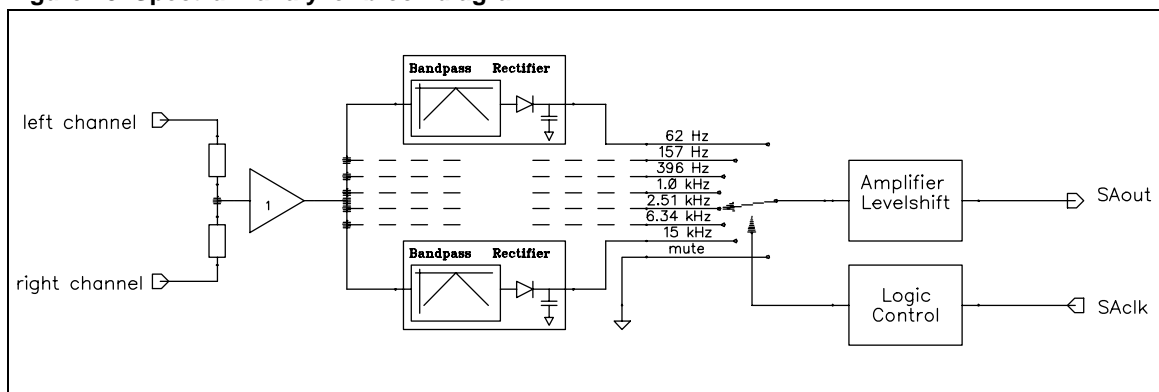
### 1.8 Spectrum analyzer

A fully integrated seven band spectrum analyzer with programmable quality factor is present in the TDA7416(Fig. 13).

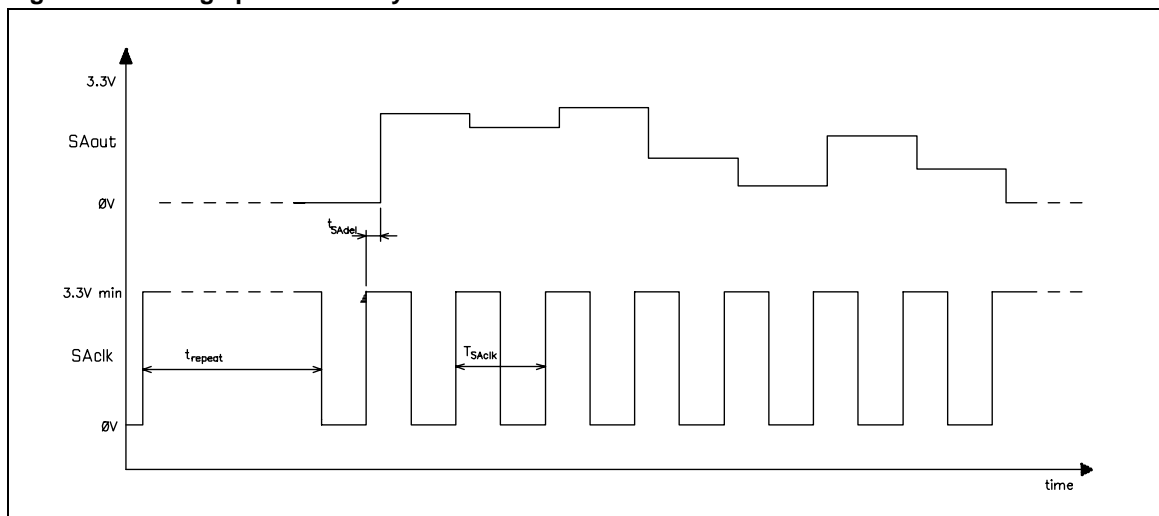
The spectrum analyzer consists of seven band pass filters with rectifier and sample capacitor which stores the maximum peak signal level since the last read cycle. This peak signal level can be read by a microprocessor at the SAout-pin. To allow easy interfacing to an analog port of the microprocessor, the output voltage at this pin is re-referred to device ground.

The microprocessor starts a read cycle with the negative going clock edge at the SAck input. On the following positive clock edges, the peak signal level for the band pass filters is subsequently switched to SAout. Each analog output data is valid after the time  $t_{SA\text{del}}$ . A reset of the sample capacitors is induced whenever SAck remains high for the time  $t_{\text{intres}}$ . Note that a proper reset requires the clock signal SAck to be held at high potential. Figure 13 shows the block diagram and figure 14 illustrates the read cycle timing of the spectrum analyzer.

**Figure 13. Spectrum analyzer block diagram**



**Figure 14. Timing spectrum analyzer**



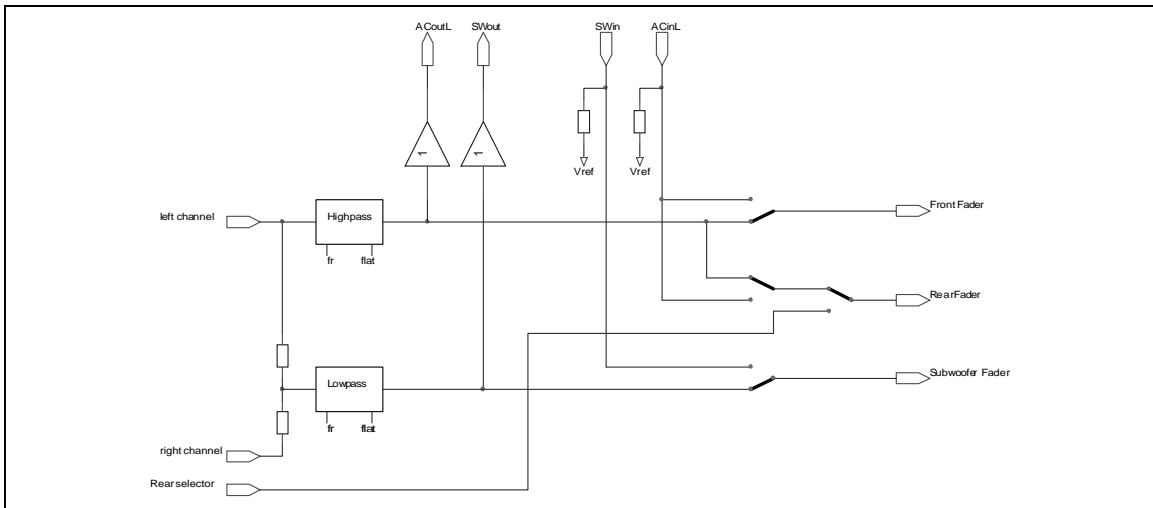
### 1.9 AC-coupling

In some applications additional signal manipulations are desired. For this purpose an AC-coupling is placed before the speaker(fader)-attenuators, which can be activated or internally shorted by I<sup>2</sup>C-Bus. In short condition the input-signal of the speaker-attenuator is available at the AC-outputs. The input-impedance of this AC-inputs is 50k . In addition there are Mix inputs available. With this inputs it is possible to mix an external signal to every speaker with a mixing ratio of 50% (see figure 14).

The source of front and rear speaker can be set independently.

- As source is choosable :
- internal dc coupling (not recommended)
  - external ac coupling using ACin pins

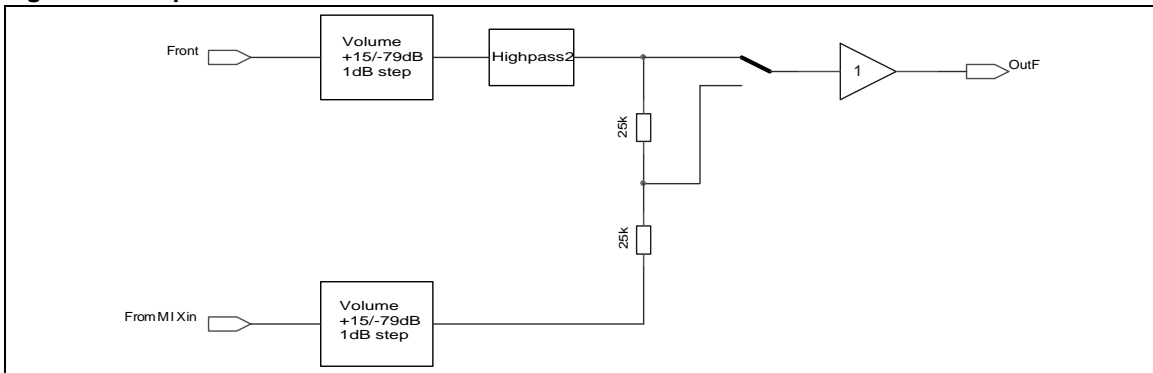
Figure 15. AC/DC-coupling



### 1.10 Front Speaker-Attenuator and Mixing

A Mixing-stage is placed after front speaker-attenuator and can be set independently to mixing-mode. Having a full volume for the Mix-signal the stage offers a wide flexibility to adapt the mixing levels.

Figure 16. Output Selector



### 1.11 Audioprocessor Testing

During the Testmode, which can be activated by setting bit I<sub>2</sub> of the subaddress byte **and** D<sub>0</sub> of the audioprocessor testing byte, several internal signals are available at the Mix pin. During this mode the input resistance of 100kOhm is disconnected from the pin. The internal signals available are shown in the Data-byte specification.







## 2.3 DATA BYTE SPECIFICATION

The status after Power-On-Reset is marked bold-face / underlined in the programming tables.

### 2.3.1 Input Selector (0)

MSB				LSB				FUNCTION
D <sub>7</sub>	D <sub>6</sub>	D <sub>5</sub>	D <sub>4</sub>	D <sub>3</sub>	D <sub>2</sub>	D <sub>1</sub>	D <sub>0</sub>	
					X	0	0	<b>Source Selector</b>
					X	0	1	BUS/PD
					X	1	0	AUX
					X	1	1	<u>MD</u>
								AM/FM
	0	0	0	0				<b>Input Gain</b>
	0	0	0	1				0dB
	:	:	:	:				1dB
	1	1	1	0				:
	1	1	1	1				14dB
								<u>15dB</u>
0								<b>Mute</b>
1								off
								<u>on</u>

### 2.3.2 Loudness (1)

MSB				LSB				FUNCTION
D <sub>7</sub>	D <sub>6</sub>	D <sub>5</sub>	D <sub>4</sub>	D <sub>3</sub>	D <sub>2</sub>	D <sub>1</sub>	D <sub>0</sub>	
			0	0	0	0	0	<b>Attenuation</b>
			0	0	0	0	1	0 dB
			:	:	:	:	:	-1 dB
			0	1	1	1	0	:
			0	1	1	1	1	-14 dB
			:	:	:	:	:	-15 dB
			1	0	0	1	1	:
			:	:	:	:	:	-19 dB
								not allowed
	0	0						<b>Center Frequency</b>
	0	1						200Hz
	1	0						400Hz
	1	1						600Hz
								<u>800Hz</u>
0								<b>Loudness Order</b>
1								First Order
								<u>Second Order</u>

2.3.3 Volume (2)

MSB							LSB		ATTENUATION
D7	D6	D5	D4	D3	D2	D1	D0		
0	0	0	0	0	0	0	0	Gain/Attenuation (+32.0dB)	
0	0	0	0	0	0	0	1	(+31.5dB)	
:	:	:	:	:	:	:	:	:	
0	0	0	1	1	0	0	0	+20.0dB	
0	0	0	1	1	0	0	1	+19.5dB	
0	0	0	1	1	0	1	0	+19.0dB	
:	:	:	:	:	:	:	:	:	
0	0	1	1	1	1	1	1	+0.5dB	
0	1	0	0	0	0	0	0	0.0dB	
0	1	0	0	0	0	0	1	-0.5dB	
:	:	:	:	:	:	:	:	:	
1	1	X	1	1	1	1	0	-79.0dB	
1	1	X	1	1	1	1	1	-79.5dB	

**Note:** It is not recommended to use a gain more than 20dB for system performance reason. In general, the max. gain should be limited by software to the maximum value, which is needed for the system.

2.3.4 Equalizer (3,4,5,6,7,8,9)

MSB							LSB		FUNCTION
D7	D6	D5	D4	D3	D2	D1	D0		
			0	0	0	0	0	Equalizer cut/boost level	
			0	0	0	0	1	-15dB	
			:	:	:	:	:	-14dB	
			0	1	1	1	0	-1dB	
			0	1	1	1	1	0dB	
			1	1	1	1	1	0dB	
			1	1	1	1	0	+1dB	
			:	:	:	:	:	:	
			1	0	0	0	1	+14dB	
			1	0	0	0	0	+15dB	
	0	0						Equalizer Q-Factor	
	0	1						2.2	
	1	0						1.8	
	1	1						1.4	
								1.0	
0								Equalizer Center Frequency (only Subaddresses 3,8,9)	
1								62Hz(addr 3)/4kHz(addr 8)/15kHz(addr 9)	
								100Hz(addr 3)/6.24kHz(addr 8)/16kHz(addr 9)	
0								DC mode EQ Band 1 (62/100 Hz, Subaddress. 4!)	
1								on	
								off	



## 2.3.5 Mixing Programming (10)

MSB							LSB	FUNCTION
D7	D6	D5	D4	D3	D2	D1	D0	
							0 1	<b>Mixing Mute</b> enable
					0 0 1 1	0 1 0 1		<b>Rear Source Selector</b> BUS'(PD) AUX MD AM/FM
			0 1	0 1				<b>Mixing Target</b> Speaker LF off Speaker LF on Speaker RF off Speaker RF on
	0 1	X X						<b>ZeroCross on HPF2</b> on off
0 1								<b>Spectrum Analyzer Detect Point</b> After EQ Before EQ

## 2.3.6 SoftMute &amp; HPF2 (11)

MSB							LSB	FUNCTION
D7	D6	D5	D4	D3	D2	D1	D0	
							0 1	<b>SoftMute</b> On (Mute) Off
					0 0 1	0 1 X		<b>SoftMute Time</b> Mute time = 0.48ms Mute time = 0.96ms Mute time = 123ms
				0 1				<b>Secondary High Pass Enable</b> Filter available No Filter (Gain)
0 0 0 0 0 0 0 0 0 1 1 1	0 0 0 0 1 1 1 1 1 X X X	0 0 1 1 0 0 1 1 1 X 0 1	0 1 0 1 0 1 1 1 0 1 1 1					<b>Secondary High Pass effect (with ZeroCross)</b> 4 dB 6 dB 8 dB 10 dB 12 dB 14 dB 16 dB 18dB 20dB 22dB 0dB

**Note:** It is recommended to set D3(Filter available or not) during initial mute.

## 2.3.7 Subwoofer Configuration / Spectrum Analyzer / HighPass (12)

MSB							LSB		FUNCTION
D7	D6	D5	D4	D3	D2	D1	D0		
						0 0 1 1	0 1 0 1	<b>Subwoofer Filter</b> off 80Hz <u>120Hz</u> 160Hz	
				X X	0 1			<b>Subwoofer Coupling</b> AC using SW <sub>In</sub> pin <u>DC</u>	
			0 1					<b>Spectrum Analyzer Q-Factor</b> 3.5 <u>1.8</u>	
		0 1						<b>High Pass Enable</b> Filter off <u>Filter on</u>	
0 0 1 1	0 1 0 1							<b>High Pass Cut-Off-Frequency</b> 90Hz 135Hz 180Hz <u>225Hz</u>	

## 2.3.8 Configuration Audioprocessor I (13)

MSB							LSB		FUNCTION
D7	D6	D5	D4	D3	D2	D1	D0		
							0 1	<b>PD Input Mode</b> single ended pseudo differential	
						0 1		<b>PD Input Gain</b> -6 dB <u>0 dB</u>	
					0 1			<b>SoftStep Volume</b> off <u>on</u>	
			0 0 1 1	0 1 0 1				<b>SoftStep Time</b> 320µs 1.28ms 5.12ms <u>20.4ms</u>	
		0 1						<b>Loudness</b> flat <u>filter ON</u>	
	0 1							<b>Front AC Speaker</b> AC coupling (ACin) <u>DC coupling</u>	
0 1								<b>Rear effect</b> No effect signal Equalizing signal	

## 2.3.9 Mixer Level Control (14)

MSB							LSB	ATTENUATION
D7	D6	D5	D4	D3	D2	D1	D0	
1	0	0	0	1	1	1	1	<b>Gain/Attenuation</b> +15dB
:	:	:	:	:	:	:	:	:
1	0	0	0	0	0	0	1	+ 1dB
1	0	0	0	0	0	0	0	0dB
0	0	0	0	0	0	0	0	0dB
0	0	0	0	0	0	0	1	- 1dB
:	:	:	:	:	:	:	:	:
0	0	0	0	1	1	1	1	-15dB
0	0	0	1	0	0	0	0	-16dB
:	:	:	:	:	:	:	:	:
0	1	0	0	1	1	1	0	-78dB
0	1	0	0	1	1	1	1	-79dB
X	1	1	X	X	X	X	X	Mute

## 2.3.10 Speaker and Subwoofer Level Control (15,16,17,18,19)

MSB							LSB	ATTENUATION
D7	D6	D5	D4	D3	D2	D1	D0	
	0	0	0	1	1	1	1	<b>Gain/Attenuation</b> +15dB
	:	:	:	:	:	:	:	:
	0	0	0	0	0	0	1	+ 1dB
	0	0	0	0	0	0	0	0dB
	0	0	1	0	0	0	0	0dB
	0	0	1	0	0	0	1	- 1dB
	:	:	:	:	:	:	:	:
	0	1	0	0	0	0	0	-16dB
	:	:	:	:	:	:	:	:
	0	1	1	0	0	0	0	-32dB
	:	:	:	:	:	:	:	:
	1	0	0	0	0	0	0	-48dB
	:	:	:	:	:	:	:	:
	1	0	1	0	0	0	0	-64dB
	:	:	:	:	:	:	:	:
	1	0	1	1	1	1	1	-79dB
	1	1	X	X	X	X	X	Mute
0								<b>SoftStep On/Off</b> On
1								Off

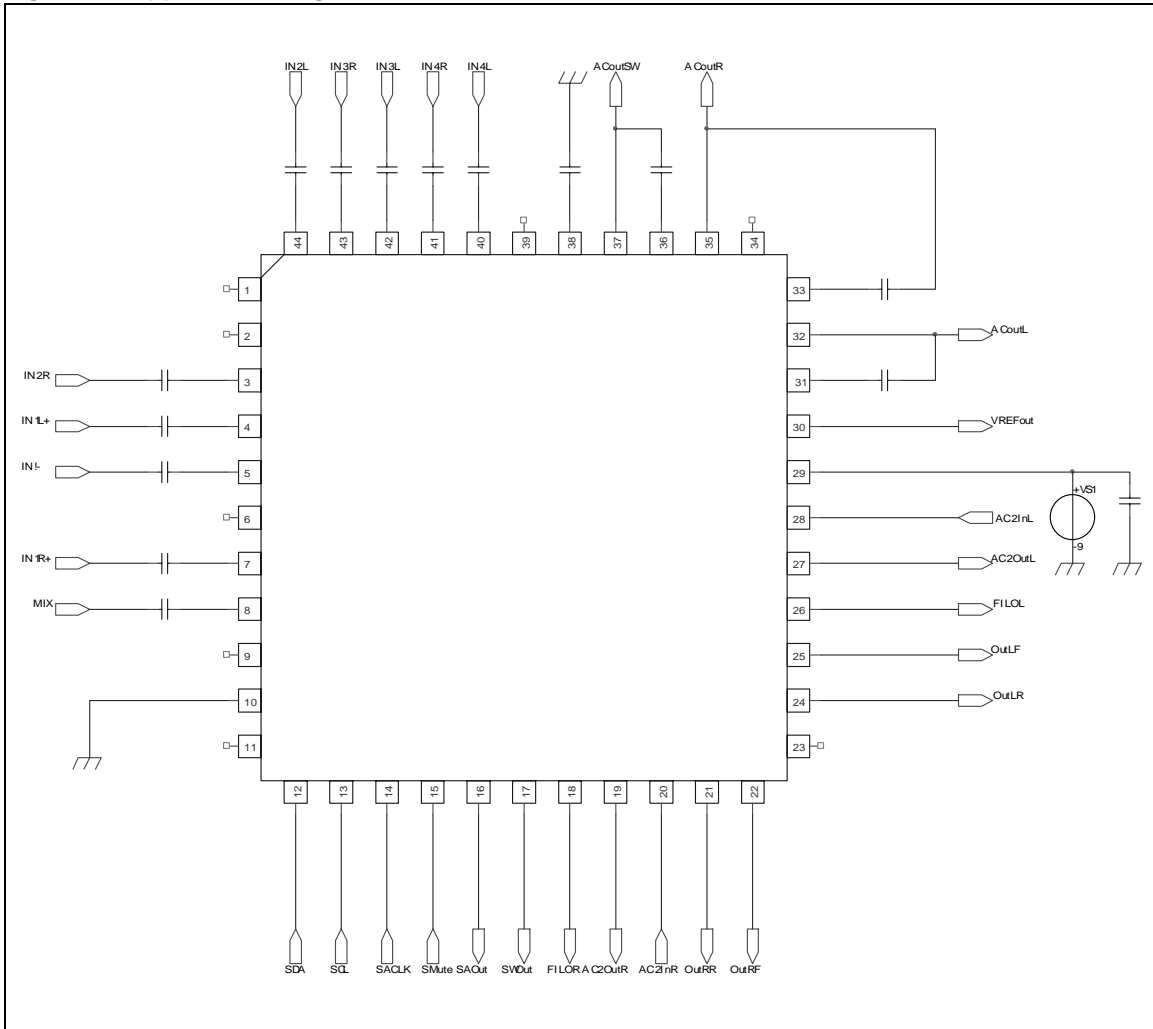
## 2.3.11 Testing Audioprocessor (20)

MSB							LSB	FUNCTION
D7	D6	D5	D4	D3	D2	D1	D0	
							0 1	<b>Audioprocessor Testmode</b> off on
			0 1 0 1 0 1 X 0 1 X X X	0 0 0 0 0 1 0 1 1 1 1	0 0 0 0 1 1 1 0 0 0 1 1	0 0 0 1 0 1 1 0 0 1 0 1		<b>Test-Multiplexer</b> Spectrum Analyzer Filter 62Hz Spectrum Analyzer Filter 157Hz Spectrum Analyzer Filter 396Hz Spectrum Analyzer Filter 1kHz Spectrum Analyzer Filter 2.51kHz Spectrum Analyzer Filter 6.34kHz Spectrum Analyzer Filter 16kHz Switch-Ron measurement setup (Level input) not used 200kHz Oscillator NB-Hold <u>internal Reference</u>
		0 1						<b>Clock</b> external <u>internal</u>
	0 1							<b>AZ Function</b> off <u>on</u>
0 1								<b>SC-Clock</b> Fast Mode <u>Normal Mode</u>

**Note:** This byte is used for testing or evaluation purposes only and must not set to other values than "11111110" in the application!

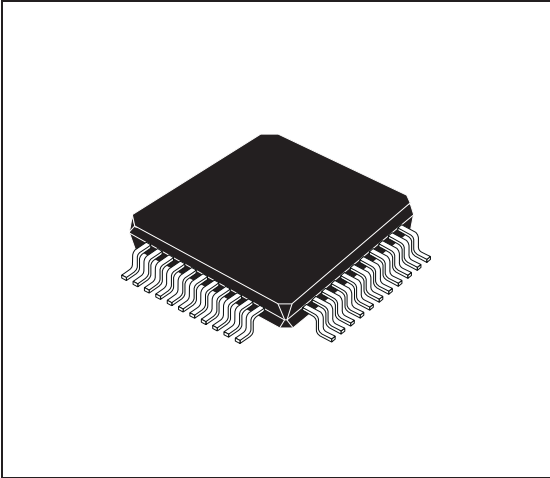


Figure 17. Application Diagram

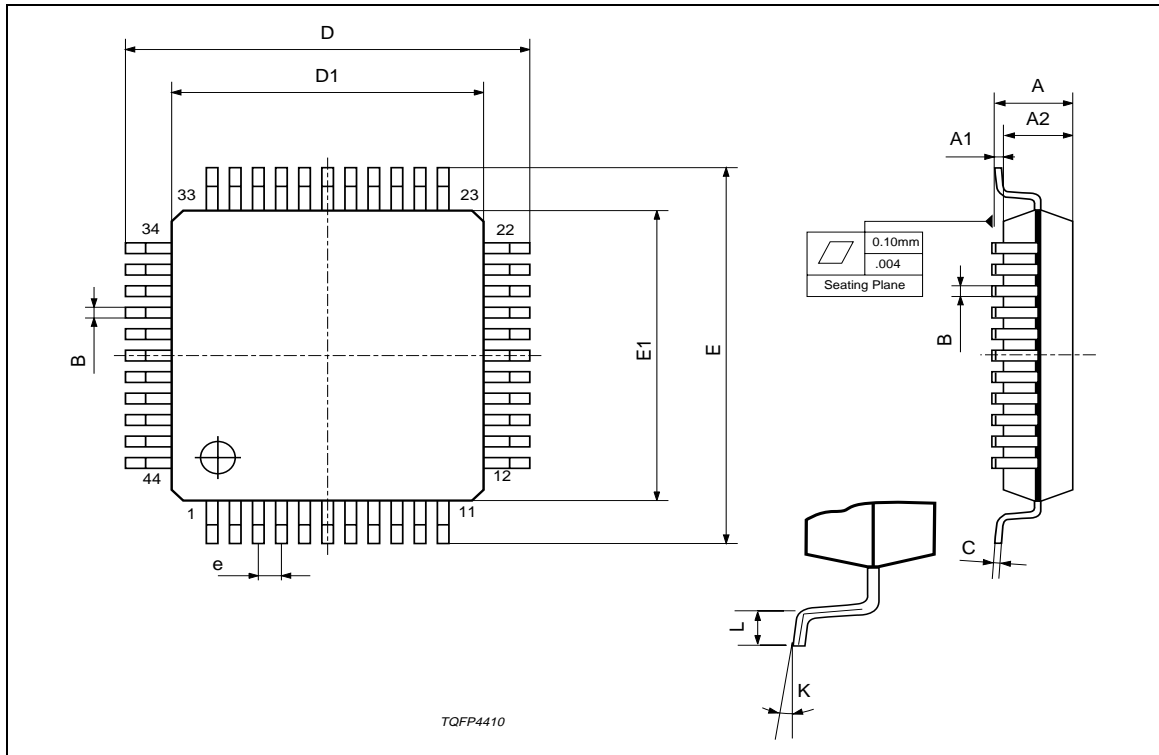


DIM.	mm			inch		
	MIN.	TYP.	MAX.	MIN.	TYP.	MAX.
A			1.60			0.063
A1	0.05		0.15	0.002		0.006
A2	1.35	1.40	1.45	0.053	0.055	0.057
B	0.30	0.37	0.45	0.012	0.014	0.018
C	0.09		0.20	0.004		0.008
D		12.00			0.472	
D1		10.00			0.394	
D3		8.00			0.315	
e		0.80			0.031	
E		12.00			0.472	
E1		10.00			0.394	
E3		8.00			0.315	
L	0.45	0.60	0.75	0.018	0.024	0.030
L1		1.00			0.039	
K	0°(min.), 3.5°(typ.), 7°(max.)					

**OUTLINE AND MECHANICAL DATA**



**TQFP44 (10 x 10)**



Information furnished is believed to be accurate and reliable. However, STMicroelectronics assumes no responsibility for the consequences of use of such information nor for any infringement of patents or other rights of third parties which may result from its use. No license is granted by implication or otherwise under any patent or patent rights of STMicroelectronics. Specifications mentioned in this publication are subject to change without notice. This publication supersedes and replaces all information previously supplied. STMicroelectronics products are not authorized for use as critical components in life support devices or systems without express written approval of STMicroelectronics.

The ST logo is a registered trademark of STMicroelectronics.  
All other names are the property of their respective owners

© 2003 STMicroelectronics - All rights reserved

**STMicroelectronics GROUP OF COMPANIES**

Australia - Belgium - Brazil - Canada - China - Czech Republic - Finland - France - Germany - Hong Kong - India - Israel - Italy - Japan - Malaysia - Malta - Morocco - Singapore - Spain - Sweden - Switzerland - United Kingdom - United States

[www.st.com](http://www.st.com)

