

Sound Processors for Home Theater Systems

5.1ch Sound Processors

BD3813KS, BD3815KS

No.10081EAT04

●Description

The BD3813KS and BD3815KS sound processors integrate a gain amp and volume/bass/treble controls on a single chip, making them optimally suited for use in audio applications, such as AV receivers, home theater systems and mini-component systems. Used in combination with the BD3812F, a 2ch volume IC, the units enable 6.1ch and 7.1ch operation. In addition, utilization of a BiCMOS process ensures a wide dynamic range (129dB).

●Features

- 1) Wide dynamic range: 129dB (Tone Bypass, VOL=MUTE, IHF-A)
- 2) Independent 6 channels for Master Volume (0 to -95 dB, MUTE 1dB/Step)
Implementation of a resistance ladder type circuit reduces residual noise and shock sounds during switching.
- 3) Low current consumption achieved through utilization of BiCMOS processes
- 4) Maximum output voltage: 4.2Vrms (Vcc=7V, VEE=-7V, RL=10kΩ)
- 5) Built-in 5ch independent input gain amplifier - useful for amplifying input signals
- 6) Built-in 2ch output port
- 7) 2-wire serial control (for both 3.3V and 5V)

●Applications

AV receivers, home theater systems and mini-component systems

●Line up matrix

Parameter	BD3813KS	BD3815KS
Mode Selector	Yes	Yes
Input Gain	0, 6, 12dB	0, 6, 18dB
Volume	0 to -95dB 1dB/Step	0 to -95dB 1dB/Step
Bass, Treble	±14dB 2dB/Step	±14dB 2dB/Step
Number of Ports	2	2
Package	SQFP56	SQFP56

● Absolute maximum ratings (Ta=25°C)

Parameter	Symbol	Ratings	Unit
Power Supply Voltage	V _{CC}	7.5 ^{*1}	V
	V _{EE}	-7.5	
Input Signal Voltage	V _{IN}	V _{CC} +0.3 to V _{EE} -0.3	V
Power Dissipation	P _d	1000 ^{*2}	mW
Operating Temperature Range	Topr	20 to 75	°C
Storage Temperature Range	Tastg	55 to 125	°C

*1 Applying voltage only to the V_{CC} side, even if within the specified power supply voltage range, may cause excessive current to flow, resulting in permanent damage to the IC. Therefore, when starting up the power supplies, V_{EE} and V_{CC} should either be powered ON simultaneously, or V_{EE} first, followed by V_{CC}.

*2 Please note the derating characteristics above Ta=25°C: 10mW/°C (Mounted on a 70mmx70mmx1.6mm sized board).

● Operating conditions

(Normal function at Ta=25°C)

Parameter	Symbol	Ratings			Unit
		Min.	Typ.	Max.	
Operating Supply Voltage	V _{CC}	5	7	7.3	V
	V _{EE}	-7.3	-7	-5	

●Electrical Characteristics

Ta=25°C, VCC=7V, VEE=-7V, f=1kHz, VIN=1Vrms, RL=10kΩ, Rg=600Ω

Input Gain=0dB, Master Volume=0dB, Bass bnd Treble=0dB, Unless otherwise noted.

	Parameter		Symbol	Limits			Unit	Conditions
				Min.	Typ.	Max.		
Total Output	Circuit Current	VCC	IQ	—	10	20	mA	No signal
		VEE		-20	-10	—		
	Output Voltage Gain 1		Gv1	-2	0	2	dB	Measure : Pin31, 29, 27, 25, 23, 21
	Output Voltage Gain 2		Gv2	-2	0	2	dB	Measure : Pin19
	Total Harmonic Distortion ratio 1		THD1	—	0.004	0.05	%	Measure : Pin31, 29, 27, 25, 23, 21 BW=400~30kHz
	Total Harmonic Distortion ratio 2		THD2	—	0.004	0.05	%	Measure : Pin19 BW=400~30kHz
	Maximum Output Voltage 1		Vomax1	3.4	4.2	—	Vrms	Measure : Pin31, 29, 27, 25, 23, 21 THD=1%
	Maximum Output Voltage 2		Vomax2	3.4	4.2	—	Vrms	Measure : Pin19 THD=1%
	Output Noise Voltage 1		Vno1	—	2.0	12	μVrms	Measure : Pin 31,29 Rg=0Ω, Tone: ON, BW=IHF-A
				—	1.5	8.0	μVrms	Measure : Pin 31,29 Rg=0Ω, Tone: By-pass, BW=IHF-A
	Output Noise Voltage 2		Vno2	—	1.5	8.0	μVrms	Measure : Pin 27,25,23,21 Rg=0Ω, BW=IHF-A
	Output Noise Voltage 3		Vno3	—	1.0	5.0	μVrms	Measure : Pin 19 Rg=0Ω, BW=IHF-A
	Crosstalk between Channels Rch→Lch		CTCRL	—	-95	-80	dB	Measure : Pin29(OUTFL) Rg=0Ω, BW=IHF-A Reference : Pin31(OUTFR)=1Vrms
	Crosstalk between Channels Lch→Rch		CTCLR	—	-95	-80	dB	Measure : Pin31(OUTFR) Rg=0Ω, BW=IHF-A Reference : Pin29(OUTFL)=1Vrms
	Crosstalk between Selectors DVD		CTSA	—	-95	-80	dB	Measure : Pin 31,29,27,25, 23,21,19 Rg=0Ω, BW=IHF-A
Crosstalk between Selectors D/A		CTSB	—	-95	-80	dB	Measure : Pin 31,29,27,25, 23,21,19 Rg=0Ω, BW=IHF-A	

	Parameter	Symbol	Limits			Unit	Conditions
			Min.	Typ.	Max.		
Volume Output	Volume Control Range	GVR	-98	-95	-92	dB	Measure : Pin31, 29, 27, 25, 23, 21 Vin=3Vrms
	Volume Setting Error 1	VE1	-2	0	2	dB	0 to -53dB Measure : Pin31, 29, 27, 25, 23, 21 Vin=3Vrms
	Volume Setting Error 2	VE2	-3	0	3	dB	-54 to -95dB Measure : Pin31, 29, 27, 25, 23, 21 Vin=3Vrms
	Channel Balance	VCB	-0.5	0	0.5	dB	Measure : Pin31, 29, 27, 25, 23, 21 Vin=3Vrms, Volume=0dB
	Maximum Attenuation	Vmin	—	-115	-105	dB	BW=IHF-A Measure : Pin31, 29, 27, 25, 23, 21 Vin=3Vrms
Input Gain	Input Gain Control Range (BD3813KS)	GIG	10	12	14	dB	Measure : Pin31, 29, 27, 25, 23, 21, 19 Vin=0.4Vrms
	Input Gain Control Range (BD3815KS)		16	18	20	dB	Measure : Pin31, 29, 27, 25, 23, 21, 19 Vin=0.4Vrms
	Input Gain Setting Error (BD3813KS)	GIE	-2	0	2	dB	Measure : Pin31, 29, 27, 25, 23, 21, 19 Vin=0.4Vrms
	Input Gain Setting Error (BD3815KS)		-2	0	2	dB	Measure : Pin31, 29, 27, 25, 23, 21, 19 Vin=0.4Vrms
Treble	Treble Maximum Boost Gain	GTB	12	14	16	dB	Measure : Pin 31, 29 f=15kHz, VIN=0.4Vrms
	Treble Maximum Cut Gain	GTC	-16	-14	-12	dB	Measure : Pin 31, 29 f=15kHz, VIN=0.4Vrms
	Treble Step Resolution	TR	—	2	—	dB	Measure : Pin 31, 29 f=15kHz, VIN=0.4Vrms
	Treble Gain Setting Error	TE	-2	0	2	dB	Measure : Pin 31, 29 f=15kHz, VIN=0.4Vrms
Bass	Bass Maximum Boost Gain	GBB	12	14	16	dB	Measure : Pin 31, 29 f=100Hz, Vi=0.4Vrms
	Bass Maximum Cut Gain	GBC	-16	-14	-12	dB	Measure : Pin 31, 29 f=100Hz, VIN=0.4Vrms
	Bass Step Resolution	BR	—	2	—	dB	Measure : Pin 31, 29 f=100Hz, VIN=0.4Vrms
	Bass Gain Setting Error	BE	-2	0	2	dB	Measure : Pin 31, 29 f=100Hz, VIN=0.4Vrms
Port	Port H Output	PH	4.5	4.9	—	V	Measure : Pin11,12 VDD=5V, RL=47kΩ

* This product is not designed to be resistant against radiation

●Timing Chart

1) Signal Timing Conditions

- Data is read on the rising edge of the clock.
- Latch is read on the falling edge of the clock.
- The latch signal must terminate with the Low state.

*To avoid malfunction, the clock and data signals must terminate with the Low state.

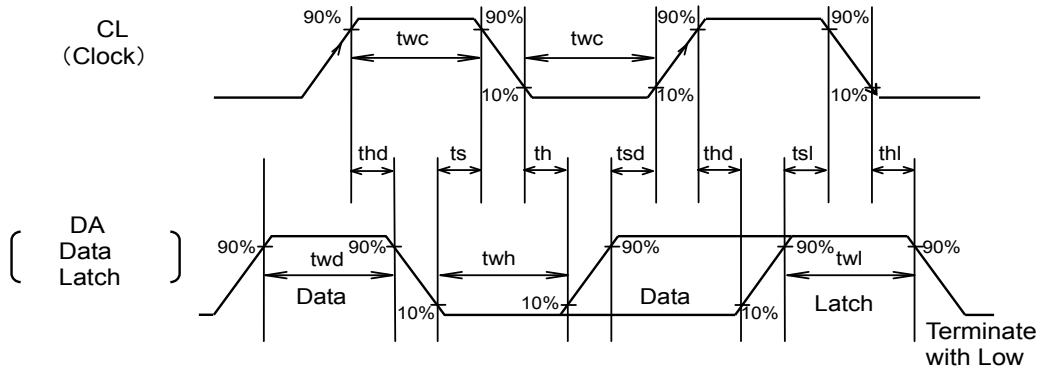

Fig.1

Parameter	Symbol	Limits			Unit
		Min.	Typ.	Max.	
Minimum Clock Width	twc	2.0	—	—	μs
Minimum Data Width	twd	2.0	—	—	μs
Minimum Latch Width	twl	2.0	—	—	μs
Low Hold Width	twh	2.0	—	—	μs
Data Set-up Time (Data→Clock)	tsd	1.0	—	—	μs
Data Hold Time (Clock → Data)	thd	1.0	—	—	μs
Latch Set-up Time (Clock →Latch)	tsl	1.0	—	—	μs
Latch Hold Time (Data → Latch)	thl	1.0	—	—	μs
Latch Low Set-up Time	ts	1.0	—	—	μs
Latch Low Hold Time	th	1.0	—	—	μs

2) Control Signal Voltage Conditions

Parameter	Condition	Limits			Unit
		Min.	Typ.	Max.(≤Vcc)	
“H” Input Voltage	Vcc=5~7.3V Vee=-5~-7.3V	2.2	—	5.5	V
“L” Input Voltage		0	—	1.0	V

3) Control Data Format - Basic Configuration

← Input direction

	MSB															LSB	
Data	D16	D15	D14	D13	D12	D11	D10	D9	D8	D7	D6	D5	D4	D3	D2	D1	D0
	Data														Select Address		

• Control Data Formats

← Input direction

																Select Address	
Data 1	D16	D15	D14	D13	D12	D11	D10	D9	D8	D7	D6	D5	D4	D3	D2	D1	D0
	Input Gain FR/FL		Input Gain SR/SL		Input Gain C		Input Gain SW		Input Gain SB		SW1 0:A 1:B	SW2 0:A 1:B	SW3 0:A 1:B	0	0	0	0
Data 2	D16	D15	D14	D13	D12	D11	D10	D9	D8	D7	D6	D5	D4	D3	D2	D1	D0
	Treble				Bass				TON E	Port A 0:L 1:H	Port B 0:L 1:H	*	*	1	0	0	0
Data 3	D16	D15	D14	D13	D12	D11	D10	D9	D8	D7	D6	D5	D4	D3	D2	D1	D0
	Master Volume FRch							Master Volume FLch							0	0	1
Data 4	D16	D15	D14	D13	D12	D11	D10	D9	D8	D7	D6	D5	D4	D3	D2	D1	D0
	Master Volume SRch							Master Volume SLch							0	1	0
Data 5	D16	D15	D14	D13	D12	D11	D10	D9	D8	D7	D6	D5	D4	D3	D2	D1	D0
	Master Volume Cch							Master Volume SWch							0	1	1

Changing the Select Address settings allows selection of four different control formats.

For Select Address, values except those shown above must not be specified.

The address data must be initialized after every power ON.

* Indicates 0 or 1.

(Example)

← Input direction

MSB	LSB	MSB	LSB	MSB	LSB	MSB	LSB	MSB	LSB
Data1	L	Data 2	L	Data 3	L	Data 4	L	Data 5	L

"L" means latch.

After power ON, only the desired data can be set for the second and subsequent times,.

(Example) When changing the bass,

Input direction

← MSB	LSB
Data 2	L

"L" means latch.

● Application Circuit

1) BD3813KS / BD3815KS

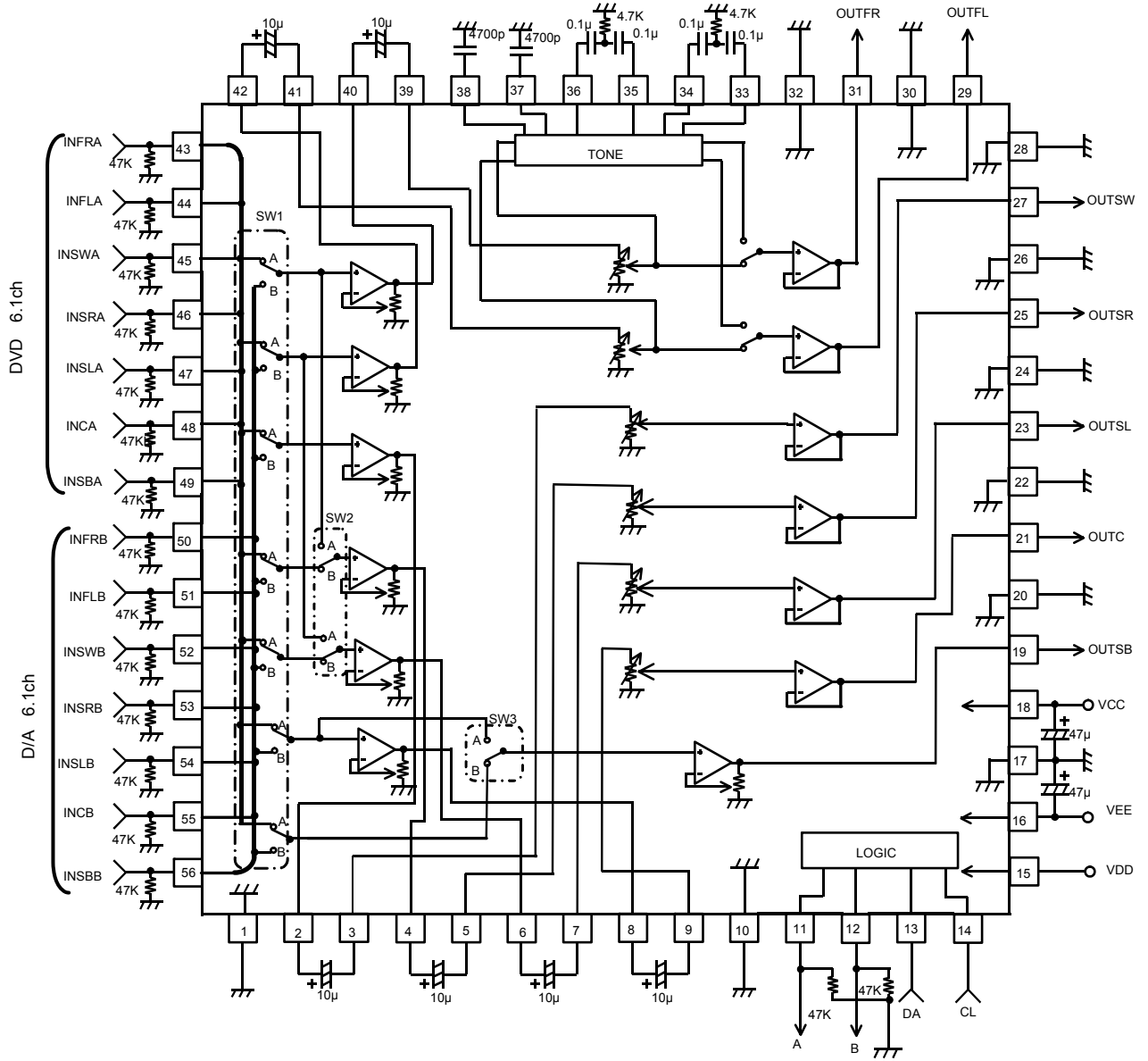

Fig. 2

Units
 Resistor: Ω
 Capacitor: F

● Pin Description

Pin No.	Pin Name	Description	Pin No.	Pin Name	Description
1	GND1	Ground pin	29	OUTFL	Lch Output pin
2	GOUTSW	Input Gain output for subwoofer pin	30	GND9	Ground pin
3	VINSW	Volume Input for subwoofer pin	31	OUTFR	Rch Output pin
4	GOUTSR	Input Gain output for surround Rch pin	32	GND10	Ground pin
5	VINSR	Volume Input for surround Rch pin	33	BNF2L	Lch Bass filter pin 2
6	GOUTSL	Input Gain output for surround Lch pin	34	BNF1L	Lch Bass filter pin 1
7	VINSL	Volume Input for surround Lch pin	35	BNF2R	Rch Bass filter pin 2
8	GOUTC	Input Gain output for center speaker pin	36	BNF1R	Lch Bass filter pin 1
9	VINC	Volume Input for center speaker pin	37	TNFL	Lch Treble filter pin
10	GND2	Ground pin	38	TNFR	Rch Treble filter pin
11	PORTA	Output for port pin	39	VINFR	Rch Volume input pin
12	PORTB	Output for port pin	40	GOUTFR	Rch Input gain output pin
13	DA	Serial data, latch input pin	41	VINFL	Lch Volume input pin
14	CL	Serial clock input pin	42	GOUTFL	Lch Input gain output pin
15	VDD	Power supply for port pin	43	INFRA	Input for Rch DVD pin
16	VEE	(-) Power supply pin	44	INFLA	Input for Lch DVD pin
17	GND3	Ground pin	45	INSWA	Input for SWch DVD pin
18	VCC	(+) Power supply pin	46	INSRA	Input for SRch DVD pin
19	OUTSB	Surround back output pin	47	INSLA	Input for SLch DVD pin
20	GND4	Ground pin	48	INCA	Input for Cch DVD pin
21	OUTC	Center speaker output pin	49	INSBA	Input for SBch DVD pin
22	GND5	Ground pin	50	INFRB	Input for Rch DSP pin
23	OUTSL	Output for surround Lch pin	51	INFLB	Input for Lch DSP pin
24	GND6	Ground pin	52	INSWB	Input for SWch DSP pin
25	OUTSR	Output for surround Rch pin	53	INSRB	Input for SRch DSP pin
26	GND7	Ground pin	54	INSLB	Input for SLch DSP pin
27	OUTSW	Subwoofer output pin	55	INCB	Input for Cch DSP pin
28	GND8	Ground pin	56	INSBB	Input for SBch DSP pin

●Equivalent Circuits

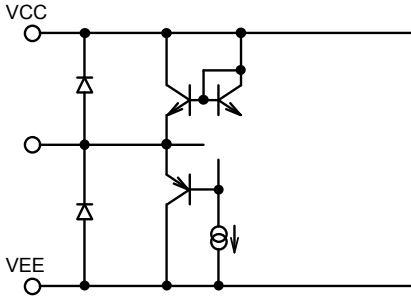
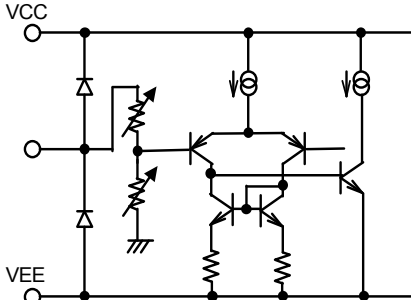
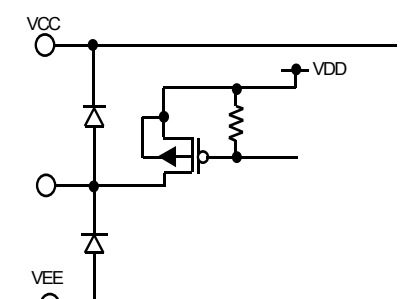
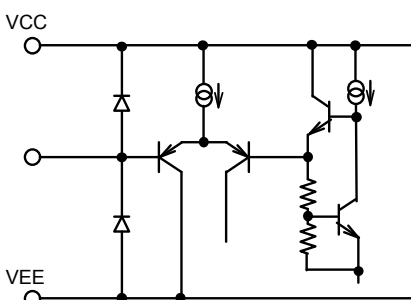
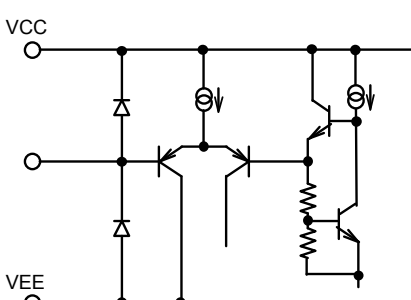
Pin No.	Pin Name	Pin Voltage	Equivalent Circuit	Description
2 4 6 8 40 42	GOUTSW GOUTSR GOUTSL GOUTC GOUTFR GOUTFL	0		Sound signal output pins from input gain
3 5 7 9 39 41	VINSW VINSR VINSL VINC VINFR VINFL	0		Sound signal input pins to master volume, Input Impedance: 20kΩ (typ.)
11 12	PORTA PORTB	—		Open drain output pins
13	DA	—		Serial data input pin
14	CL	—		Serial clock input pin

Pin No.	Pin Name	Pin Voltage	Equivalent Circuit	Description
19 21 23 25 27 29 31	OUTSB OUTC OUTSL OUTSR OUTSW OUTFL OUTFR	0		Sound signal output pins
33 35	BNF2L BNF2R	0		Bass frequency characteristic/gain setting pins
34 36	BNF1L BNF1R	0		Bass frequency characteristic/gain setting pins
37 38	TNFL TNFR	0		Treble frequency characteristic/gain setting pins
43 44 45 46 47 48 49 50 51 52 53 54 55 56	INFRA INFLA INSWA INSRA INSLA INCA INSBA INFRB INFLB INSWB INSRB INSLB INCB INSBB	0		Sound signal input pins; Input impedances determined by external resistances

OSwitch Description

Output	Input (SW1=A)		
	SW2,3=B (Default)	SW2=A SW3=B	SW2=B SW3=A
FR	FR	FR	FR
FL	FL	FL	FL
SW	SW	SW	SW
SR	SR	FR	SR
SL	SL	FL	SL
C	C	C	C
SB	SB	SB	C

SW1 A: Select input line A
B: Select input line B

SW2 A: Output the signals of the FR and FL inputs onto the Surround Outputs (SR, SL)
Used when the source is stereo.
B: Output the signals of the SR and SL inputs onto the Surround Outputs (SR, SL)
Used when the source is 5.1ch or 6.1ch.

SW3 A: Output the C input signal onto SB output
Used when the source is 5.1ch with the 6.1ch speaker system installed.
B: Output the SB input signal onto the SB output
Used when the source is 6.1ch with the 6.1ch speaker system installed.

●Setting constants for tone control filters

1) Treble filter

$$f_c = 1/2\pi(R_2)C \quad (\text{Hz})$$

$$G = 20\log(R_1 + R_2 + Z_c)/(R_2 + Z_c) \quad (\text{dB})$$

$$Z_c = 1/j\omega C \quad (\Omega)$$

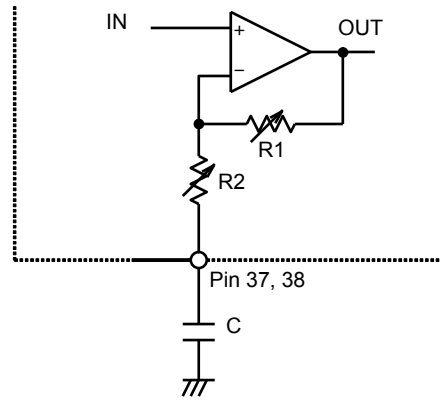

Fig.3

Standard Values of R1, R2 (Reference)

Treble Boost Amount Cut Amount	Resistance (kΩ) *Typ.	
	R1	R2
0dB	0	20
±2dB	4.1	15.9
±4dB	7.3	12.7
±6dB	10.3	9.7
±8dB	12.3	7.7
±10dB	14.0	6.0
±12dB	15.4	4.6
±14dB	16.5	3.5

*The actual boost/cut amounts may deviate from the standard values to some degree.

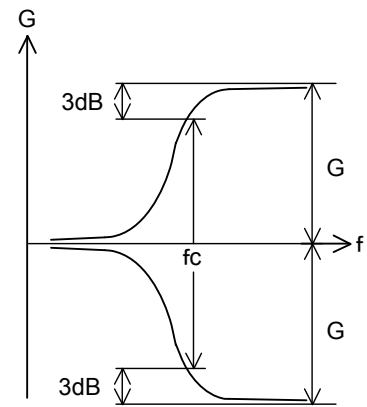

Fig.4

2) Bass Filter

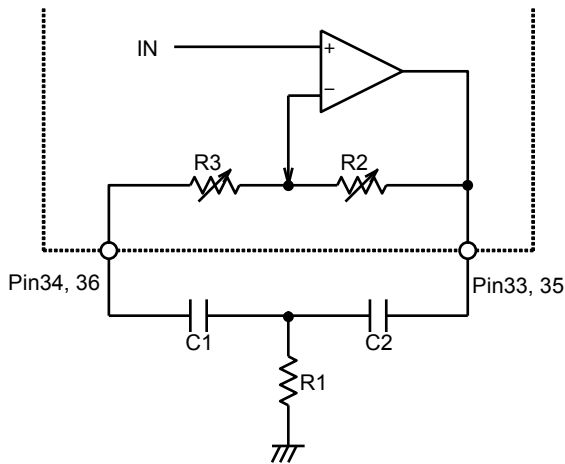

Fig. 5

$$f_0 = \frac{1}{2\pi \sqrt{R1(R2 + R3)C1C2}} \text{ (Hz)}$$

$$Q = \frac{1}{C1+C2} \sqrt{\frac{C1C2R2}{R1}}$$

when C1=C2

$$G = 20\log \frac{\frac{R2+R3}{R1} + 2}{\frac{R3}{R1} + 2} \text{ (dB)}$$

Standard values of R2, R3 (Reference)
(R1=4.7kΩ, C1=C2=0.1μF)

Boost Amount Cut Amount	Resistance (kΩ) Typ.*	
	R2	R3
0dB	0	41.0
±2dB	10.8	30.2
±4dB	19.3	21.7
±6dB	26.0	15.0
±8dB	31.2	9.8
±10dB	35.4	5.6
±12dB	38.4	2.6
±14dB	41.0	0

*The actual boost/cut amounts may deviate from the standard values in some degree.

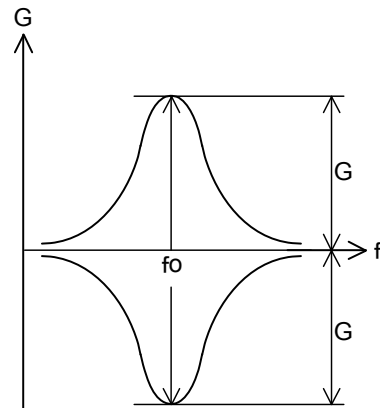

Fig.6

* Bass Filter Feature

To set the f0 and Q values of the Bass characteristics, refer to the external components of the Bass Filter shown in the upper-left figure.

●Reference Data

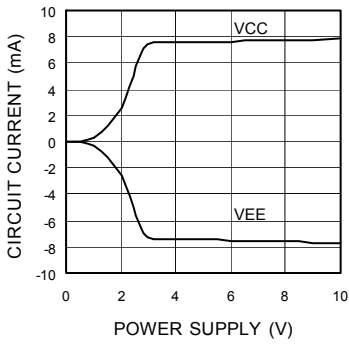

Fig.7 Circuit Current - Power Supply

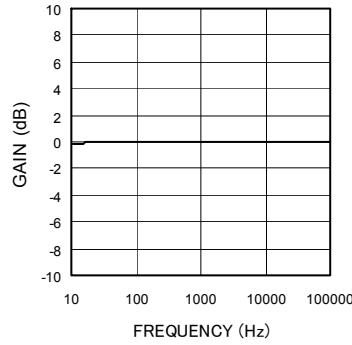

Fig.8 Voltage Gain - Frequency

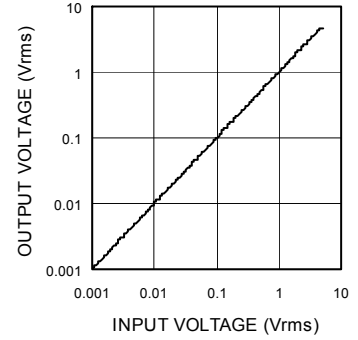

Fig.9 Output Voltage - Input Voltage

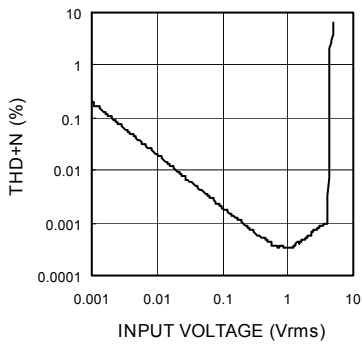

Fig.10 THD+N -Input Voltage

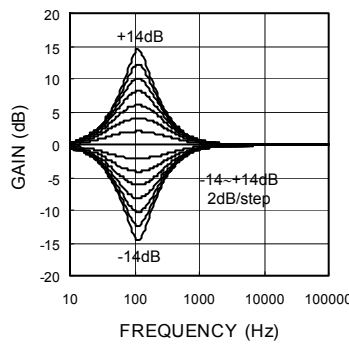

Fig.11 Bass Gain - Frequency

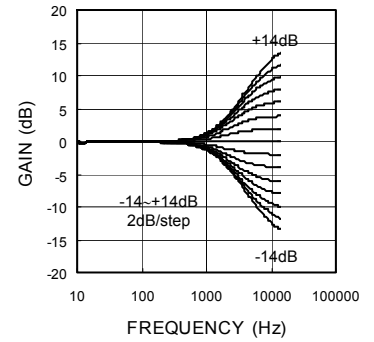

Fig.12 Treble Gain - Frequency

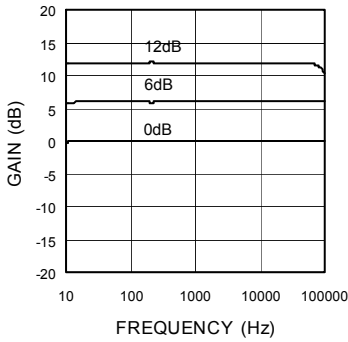

Fig.13 Input Gain - Frequency (BD3813KS)

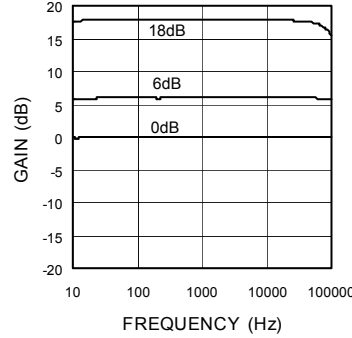

Fig.14 Input Gain - Frequency (BD3815KS)

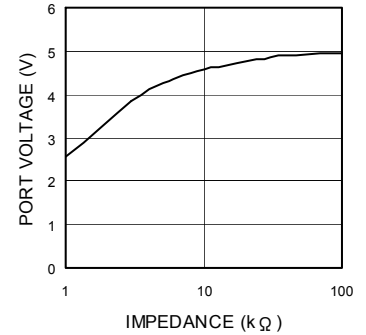

Fig.15 Port H Voltage - Load Resistance

●Notes for use

- (1) The numbers and data shown above are representative design values and are not guaranteed.
- (2) Although the sample application circuits are guaranteed, further verification of the electrical characteristics are recommended. When modifying external components before use, ensure that sufficient margins are in place by taking into account variations in the external components themselves as well as the LSI regarding both static and transient characteristics.
- (3) Absolute maximum ratings
Operating or testing the IC over the maximum ratings may damage the part itself as well as peripheral components. Therefore, please ensure that the specifications are never exceeded. In addition, implementation of fuses or other physical safety measures is recommended.
- (4) V_{EE} potential
Ensure that the V_{EE} pin voltage is at the lowest potential and that no other pin is at a lower voltage, including transient phenomena.
- (5) Thermal design
Implement thermal designs that take into account the power dissipation under actual operating conditions.
- (6) Shorts between pins and erroneous installation
Incorrect mounting may damage the IC. In addition, the presence of foreign particles between the pins, a pin and the power supply, or a pin and GND may result in destruction.
- (7) Operation in a strong magnetic field
Operation in a strong magnetic field may cause malfunction.
- (8) Serial control
The wiring pattern of the CL and DA terminals should be routed so as not to cause interference with the analog signal related lines.
- (9) Power ON/OFF
 - (a) During power ON/OFF a shock sound will be generated. Therefore, use the MUTE function.
 - (b) When turning ON the power supplies, V_{EE} and V_{CC} should either be powered on simultaneously, or V_{EE} first, followed by V_{CC} , since if V_{CC} is started up first, an excessive current may pass V_{CC} through to V_{EE} .
- (10) Function switching
For functions except the Master Volume, Treble and Bass controls, use of the MUTE function is recommended.
- (11) Port power supply
The port power supply should be turned ON following V_{CC} and V_{EE} . If the port is not used, the port power supply must be connected to V_{EE} .

● Thermal Derating Curve

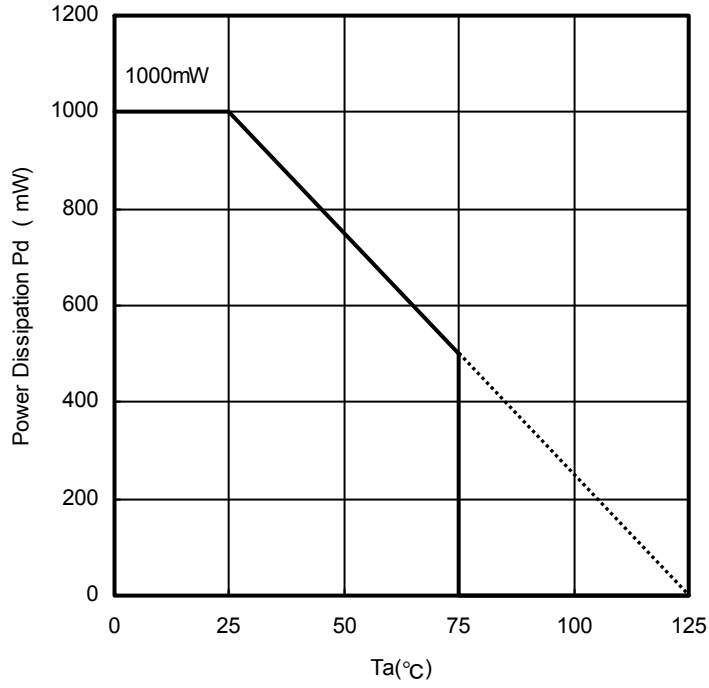

Fig. 16

BD3813KS, BD3815KS
Board size: 70mm x 70mm x 1.6mm
Raw material: FR4 glass epoxy board (copper area less than 3%)

● Ordering part number

B	D
---	---

Part No.

3	8	1	3
---	---	---	---

Part No.
3813
3815

K	S
---	---

Package
KS: SQFP56

--	--

Packaging and forming specification
None :Tray

SQFP56

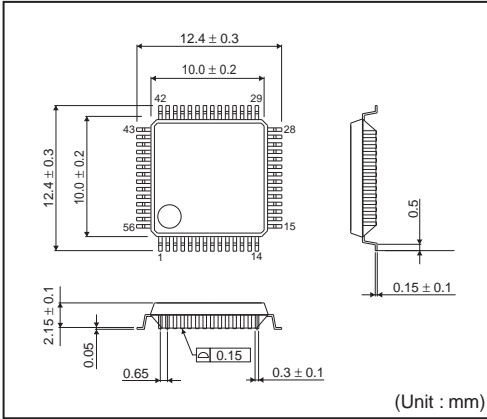

<Tape and Reel information>

Container	Tray
Quantity	1000pcs
Direction of feed	Direction of product is fixed in a tray

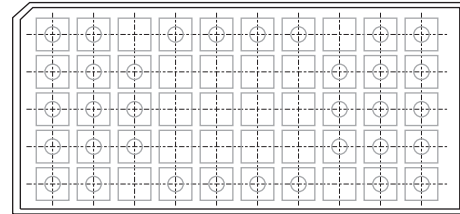
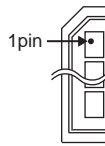

* Order quantity needs to be multiple of the minimum quantity.

Notes

No copying or reproduction of this document, in part or in whole, is permitted without the consent of ROHM Co.,Ltd.

The content specified herein is subject to change for improvement without notice.

The content specified herein is for the purpose of introducing ROHM's products (hereinafter "Products"). If you wish to use any such Product, please be sure to refer to the specifications, which can be obtained from ROHM upon request.

Examples of application circuits, circuit constants and any other information contained herein illustrate the standard usage and operations of the Products. The peripheral conditions must be taken into account when designing circuits for mass production.

Great care was taken in ensuring the accuracy of the information specified in this document. However, should you incur any damage arising from any inaccuracy or misprint of such information, ROHM shall bear no responsibility for such damage.

The technical information specified herein is intended only to show the typical functions of and examples of application circuits for the Products. ROHM does not grant you, explicitly or implicitly, any license to use or exercise intellectual property or other rights held by ROHM and other parties. ROHM shall bear no responsibility whatsoever for any dispute arising from the use of such technical information.

The Products specified in this document are intended to be used with general-use electronic equipment or devices (such as audio visual equipment, office-automation equipment, communication devices, electronic appliances and amusement devices).

The Products specified in this document are not designed to be radiation tolerant.

While ROHM always makes efforts to enhance the quality and reliability of its Products, a Product may fail or malfunction for a variety of reasons.

Please be sure to implement in your equipment using the Products safety measures to guard against the possibility of physical injury, fire or any other damage caused in the event of the failure of any Product, such as derating, redundancy, fire control and fail-safe designs. ROHM shall bear no responsibility whatsoever for your use of any Product outside of the prescribed scope or not in accordance with the instruction manual.

The Products are not designed or manufactured to be used with any equipment, device or system which requires an extremely high level of reliability the failure or malfunction of which may result in a direct threat to human life or create a risk of human injury (such as a medical instrument, transportation equipment, aerospace machinery, nuclear-reactor controller, fuel-controller or other safety device). ROHM shall bear no responsibility in any way for use of any of the Products for the above special purposes. If a Product is intended to be used for any such special purpose, please contact a ROHM sales representative before purchasing.

If you intend to export or ship overseas any Product or technology specified herein that may be controlled under the Foreign Exchange and the Foreign Trade Law, you will be required to obtain a license or permit under the Law.



Thank you for your accessing to ROHM product informations.
More detail product informations and catalogs are available, please contact us.

ROHM Customer Support System

<http://www.rohm.com/contact/>