

TONE CONTROL DIGITALLY CONTROLLED AUDIO PROCESSOR

1 FEATURES

- INPUT MULTIPLEXER
 - 4 STEREO INPUTS
 - SELECTABLE INPUT GAIN FOR OPTIMAL ADAPTATION TO DIFFERENT SOURCES
- ONE STEREO OUTPUT
- TREBLE AND BASS CONTROL IN 2.0dB STEPS
- VOLUME CONTROL IN 1.0dB STEPS
- TWO SPEAKER ATTENUATORS:
 - TWO INDEPENDENT SPEAKER CONTROL IN 1.0dB STEPS FOR BALANCE FACILITY
 - INDEPENDENT MUTE FUNCTION
- ALL FUNCTION ARE PROGRAMMABLE VIA SERIAL BUS

2 DESCRIPTION

The TDA7440D is a volume tone (bass and treble) balance (Left/Right) processor for quality audio applications in Hi-Fi systems.

Figure 1. Package

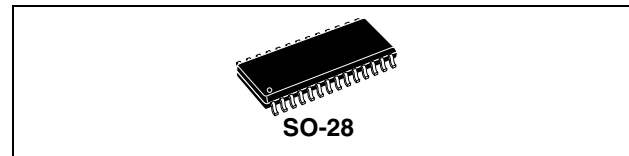

Table 1. Order Codes

Order code	Package
TDA7440D	SO-28
TDA7440D013TR	Tape & Reel

Selectable input gain is provided. Control of all the functions is accomplished by serial bus.

The AC signal setting is obtained by resistor networks and switches combined with operational amplifiers.

Thanks to the used BIPOLAR/CMOS Technology, Low Distortion, Low Noise and DC stepping are obtained

Figure 2. Block Diagram

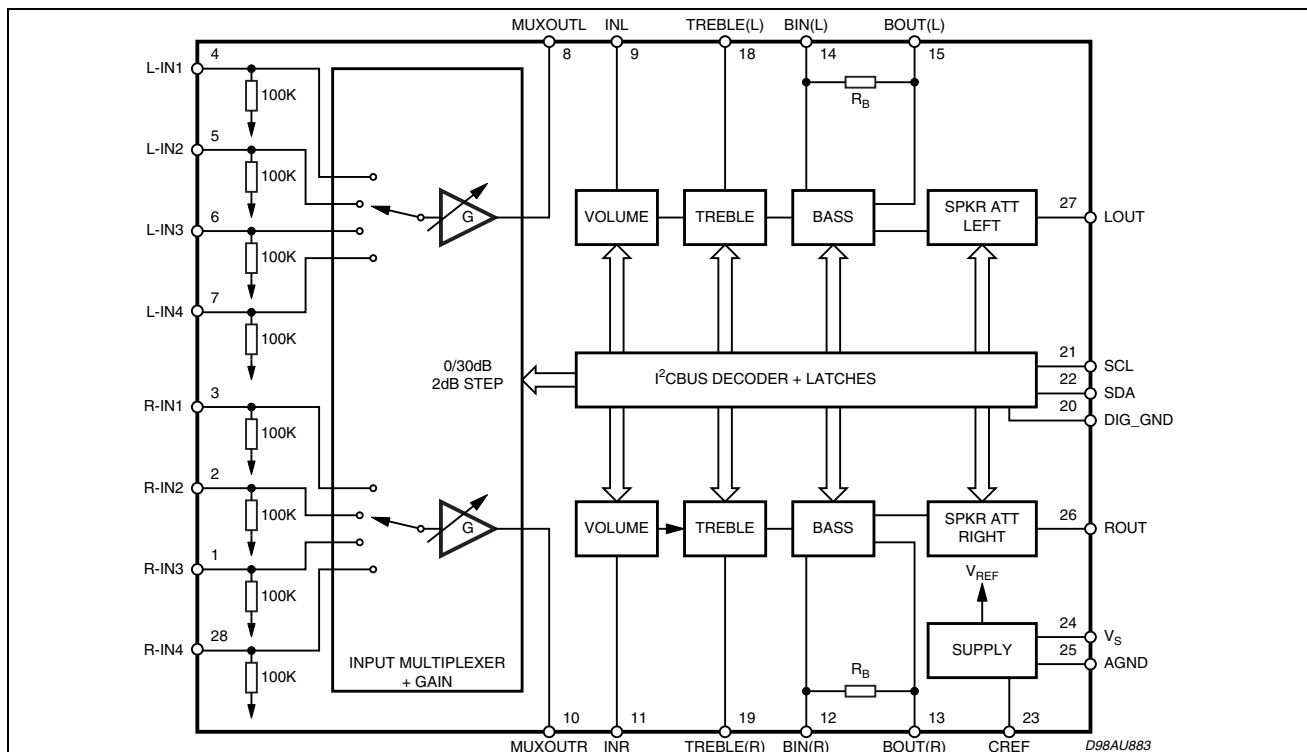

Figure 3. Pin Connection (Top view)

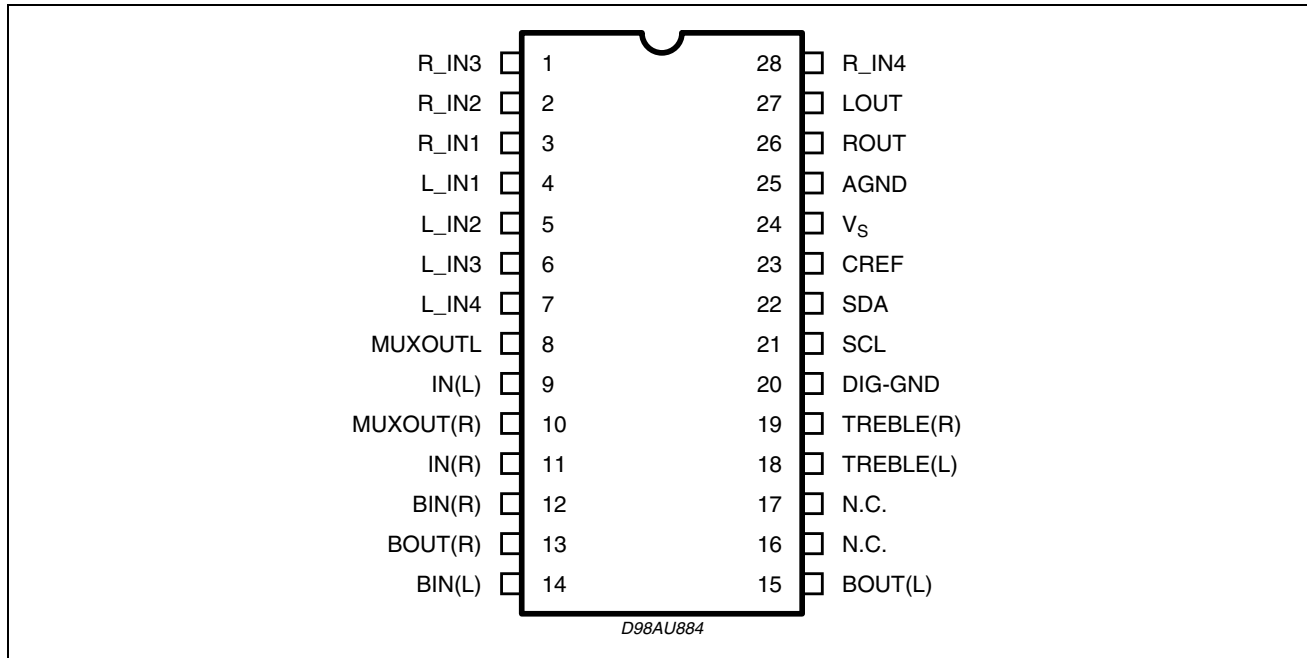

Table 2. Absolute Maximum Ratings

Symbol	Parameter	Value	Unit
V _S	Operating Supply Voltage	10.5	V
T _{amb}	Operating Ambient Temperature	0 to 70	°C
T _{stg}	Storage Temperature Range	-55 to 150	°C

Table 3. Thermal Data

Symbol	Parameter	Value	Unit
R _{th j-pin}	Thermal Resistance Junction-pins	85	°C/W

Table 4. Quick Reference Data

Symbol	Parameter	Min.	Typ.	Max.	Unit
V _S	Supply Voltage	6	9	10.2	V
V _{CL}	Max. input signal handling	2			V _{rms}
THD	Total Harmonic Distortion V = 1V _{rms} f = 1KHz	0.01	0.1	%	
S/N	Signal to Noise Ratio V _{out} = 1V _{rms} (mode = OFF)		106		dB
S _C	Channel Separation f = 1KHz		90		dB
	Input Gain in (2dB step)	0		30	dB
	Volume Control (1dB step)	-47		0	dB
	Treble Control (2dB step)	-14		+14	dB
	Bass Control (2dB step)	-14		+14	dB
	Balance Control 1dB step	-79		0	dB
	Mute Attenuation		100		dB

Table 5. Electrical Characteristics

Refer to the test circuit $T_{amb} = 25^{\circ}\text{C}$, $V_S = 9\text{V}$, $R_L = 10\text{K}\Omega$, $R_G = 600\Omega$, all controls flat ($G = 0\text{dB}$), unless otherwise specified.

Symbol	Parameter	Test Condition	Min.	Typ.	Max.	Unit
SUPPLY						
V_S	Supply Voltage		6	9	10.2	V
I_S	Supply Current		4	7	10	mA
SVR	Ripple Rejection		60	90		dB
INPUT STAGE						
R_{IN}	Input Resistance		70	100	130	$\text{K}\Omega$
V_{CL}	Clipping Level	THD = 0.3%	2	2.5		V _{rms}
S_{IN}	Input Separation	The selected input is grounded through a 2.2μ capacitor	80	100		dB
G_{inmin}	Minimum Input Gain		-1	0	1	dB
G_{inmax}	Maximum Input Gain		29	30	31	dB
G_{step}	Step Resolution		1.5	2	2.5	dB
VOLUME CONTROL						
R_i	Input Resistance		20	33	50	$\text{K}\Omega$
C_{RANGE}	Control Range		45	47	49	dB
A_{VMAX}	Max. Attenuation		45	47	49	dB
A_{STEP}	Step Resolution		0.5	1	1.5	dB
E_A	Attenuation Set Error	$A_V = 0$ to -24dB	-1.0	0	1.0	dB
		$A_V = -24$ to -47dB	-1.5	0	1.5	dB
E_T	Tracking Error	$A_V = 0$ to -24dB		0	1	dB
		$A_V = -24$ to -47dB		0	2	dB
V_{DC}	DC Step	adjacent attenuation steps from 0dB to A_V max		0 0.5	3	mV mV
A_{mute}	Mute Attenuation		80	100		dB
BASS CONTROL (1)						
G_b	Control Range	Max. Boost/cut	+12.0	+14.0	+16.0	dB
B_{STEP}	Step Resolution		1	2	3	dB
R_B	Internal Feedback Resistance		33	44	55	$\text{K}\Omega$
TREBLE CONTROL (1)						
G_t	Control Range	Max. Boost/cut	+13.0	+14.0	+15.0	dB
T_{STEP}	Step Resolution		1	2	3	dB
SPEAKER ATTENUATORS						
C_{RANGE}	Control Range		70	76	82	dB
S_{STEP}	Step Resolution		0.5	1	1.5	dB
E_A	Attenuation Set Error	$A_V = 0$ to -20dB	-1.5	0	1.5	dB
		$A_V = -20$ to -56dB	-2	0	2	dB
V_{DC}	DC Step	adjacent attenuation steps		0	3	mV
A_{mute}	Mute Attenuation		80	100		dB

NOTE1:

- 1) The device is functionally good at $V_S = 5\text{V}$. a step down, on V_S , to 4V doesn't reset the device.
- 2) BASS and TREBLE response: The center frequency and the response quality can be chosen by the external circuitry.

Table 5. Electrical Characteristics (continued)

Refer to the test circuit $T_{amb} = 25^{\circ}\text{C}$, $V_S = 9\text{V}$, $R_L = 10\text{K}\Omega$, $R_G = 600\Omega$, all controls flat ($G = 0\text{dB}$), unless otherwise specified.

Symbol	Parameter	Test Condition	Min.	Typ.	Max.	Unit
AUDIO OUTPUTS						
V_{CLIP}	Clipping Level	$d = 0.3\%$	2.1	2.6		Vrms
R_L	Output Load Resistance		2			$\text{K}\Omega$
R_O	Output Impedance		10	30	50	Ω
V_{DC}	DC Voltage Level		3.5	3.8	4.1	V
GENERAL						
E_{NO}	Output Noise	All gains = 0dB; BW = 20Hz to 20KHz flat		5	15	μV
E_t	Total Tracking Error	$A_V = 0$ to -24dB		0	1	dB
		$A_V = -24$ to -47dB		0	2	dB
S/N	Signal to Noise Ratio	All gains 0dB; $V_O = 1\text{Vrms}$	95	106		dB
S_C	Channel Separation Left/Right		80	100		dB
d	Distortion	$A_V = 0$; $V_I = 1\text{Vrms}$		0.01	0.08	%
BUS INPUT						
V_{IL}	Input Low Voltage				1	V
V_{IH}	Input High Voltage		3			V
I_{IN}	Input Current	$V_{IN} = 0.4\text{V}$	-5	0	5	μA
V_O	Output Voltage SDA Acknowledge	$I_O = 1.6\text{mA}$		0.4	0.8	V

Figure 4. Test Circuit

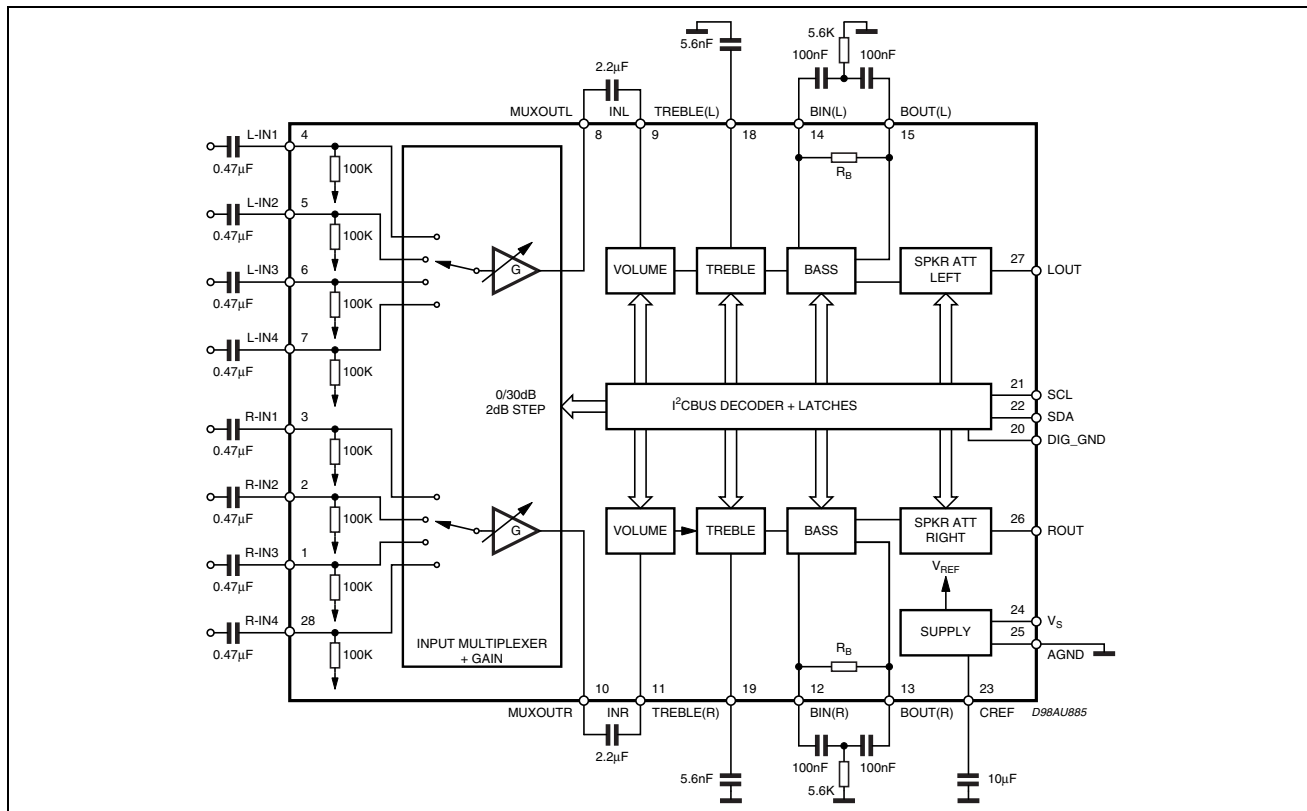

3 APPLICATION SUGGESTIONS

The first and the last stages are volume control blocks. The control range is 0 to -47dB (mute) for the first one, 0 to -79dB (mute) for the last one. Both of them have 1dB step resolution. The very high resolution allows the implementation of systems free from any noisy acoustical effect.

The TDA7440D audioprocessor provides 3 bands tones control.

3.1 Bass Stage

Several filter types can be implemented, connecting external components to the Bass IN and OUT pins.

The fig.5 refers to basic T Type Bandpass Filter starting from the filter component values (R1 internal and R2,C1,C2 external) the centre frequency F_C , the gain A_V at max. boost and the filter Q factor are computed as follows:

$$F_C = \frac{1}{2 \cdot \pi \cdot \sqrt{R_1 \cdot R_2 \cdot C_1 \cdot C_2}}$$

$$A_V = \frac{R_2 C_2 + R_2 C_1 + R_i C_1}{R_2 C_1 + R_2 C_2}$$

$$Q = \frac{\sqrt{R_1 \cdot R_2 \cdot C_1 \cdot C_2}}{R_2 C_1 + R_2 C_2}$$

Viceversa, once F_C , A_V , and R_i internal value are fixed, the external components values will be:

$$C_1 = \frac{A_V - 1}{2 \cdot \pi \cdot F_C \cdot R_i \cdot Q} \quad C_2 = \frac{Q^2 \cdot C_1}{A_V - 1 - Q^2} \quad R_2 = \frac{A_V - 1 - Q^2}{2 \cdot \pi \cdot C_1 \cdot F_C \cdot (A_V - 1) \cdot Q}$$

Figure 5.

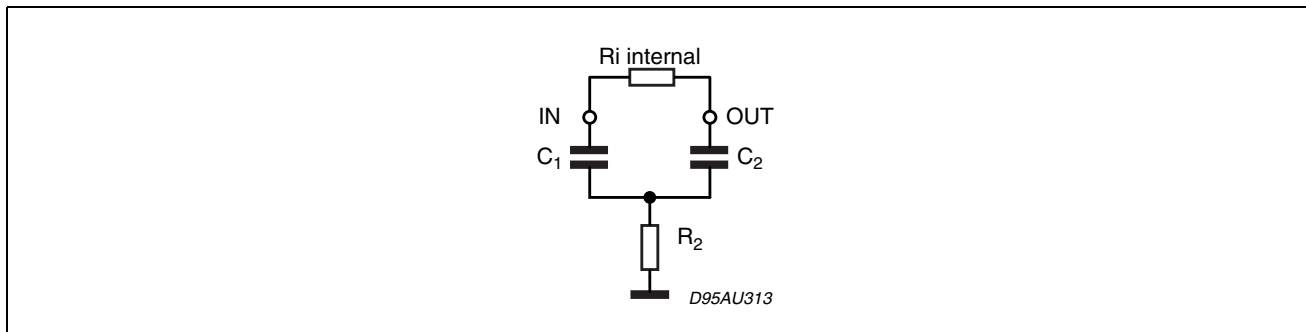

Treble Stage

The treble stage is a high pass filter whose time constant is fixed by an internal resistor (25KΩ typical) and an external capacitor connected between treble pins and ground.

Typical responses are reported in Figg. 14 to 17.

CREF

The suggested 10mF reference capacitor (CREF) value can be reduced to 4.7mF if the application requires faster power ON.

Figure 6. THD vs. frequency

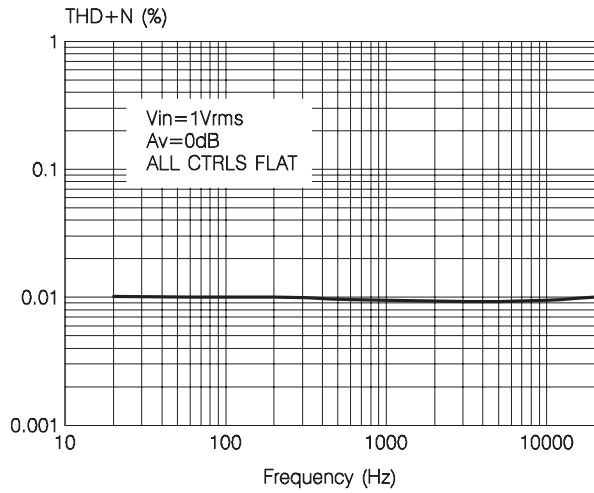

Figure 9. Bass response

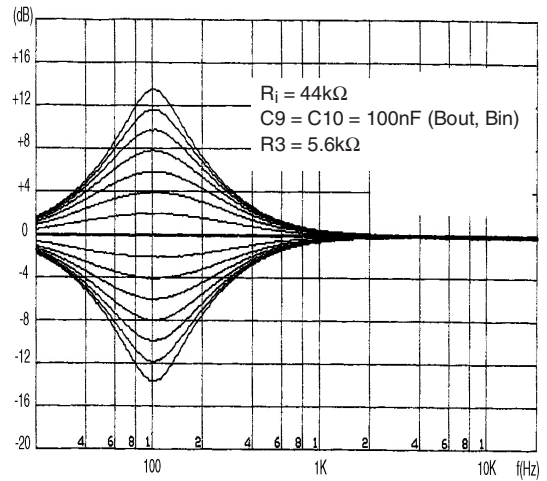

Figure 7. THD vs. R_{LOAD}

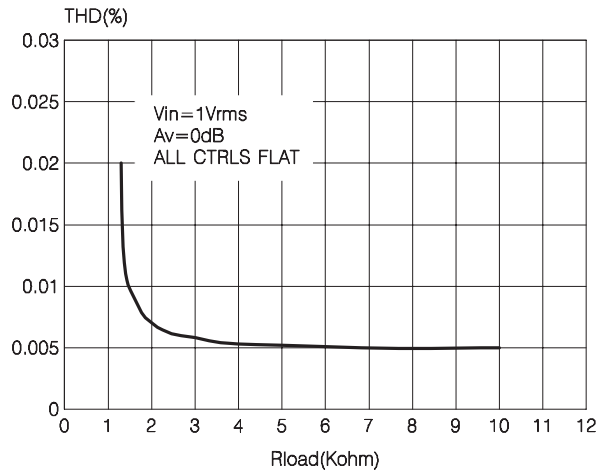

Figure 10. Treble responsey

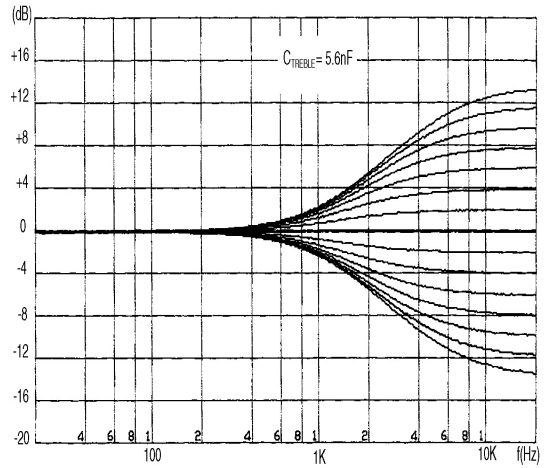
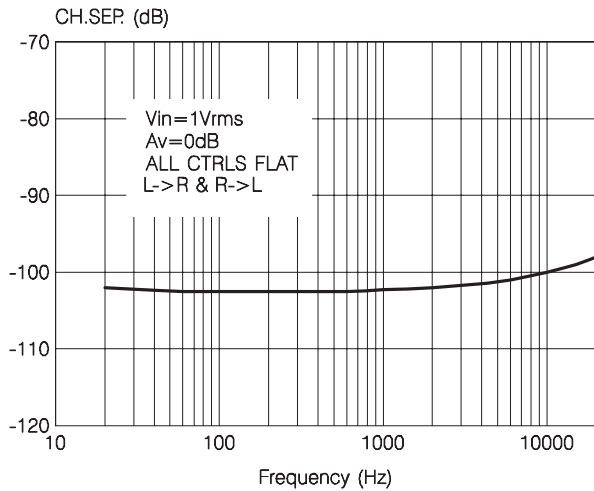

Figure 8. Channel separation vs. frequency



4 I²C BUS INTERFACE

Data transmission from microprocessor to the TDA7440D and vice versa takes place through the 2 wires I²C BUS interface, consisting of the two lines SDA and SCL (pull-up resistors to positive supply voltage must be connected).

4.1 Data Validity

As shown in fig. 11, the data on the SDA line must be stable during the high period of the clock. The HIGH and LOW state of the data line can only change when the clock signal on the SCL line is LOW.

4.2 Start and Stop Conditions

As shown in fig. 12 a start condition is a HIGH to LOW transition of the SDA line while SCL is HIGH. The stop condition is a LOW to HIGH transition of the SDA line while SCL is HIGH.

4.3 Byte Format

Every byte transferred on the SDA line must contain 8 bits. Each byte must be followed by an acknowledge bit. The MSB is transferred first.

4.4 Acknowledge

The master (μ P) puts a restive HIGH level on the SDA line during the acknowledge clock pulse (see fig. 13). The peripheral (audio processor) that acknowledges has to pull-down (LOW) the SDA line during this clock pulse.

The audio processor which has been addressed has to generate an acknowledge after the reception of each byte, otherwise the SDA line remains at the HIGH level during the ninth clock pulse time. In this case the master transmitter can generate the STOP information in order to abort the transfer.

4.5 Transmission without Acknowledge

Avoiding to detect the acknowledge of the audio processor, the μ P can use a simpler transmission: simply it waits one clock without checking the slave acknowledging, and sends the new data.

This approach of course is less protected from misworking.

Figure 11. Data Validity on the I²CBUS

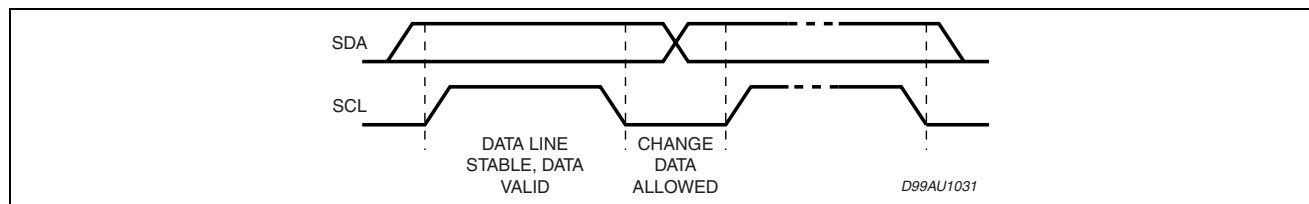

Figure 12. Timing Diagram of I²CBUS

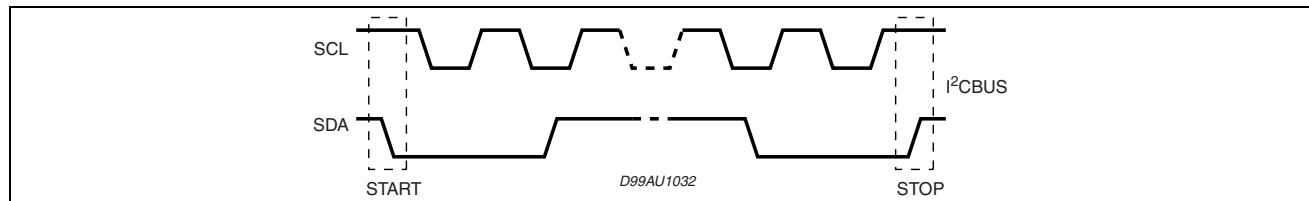
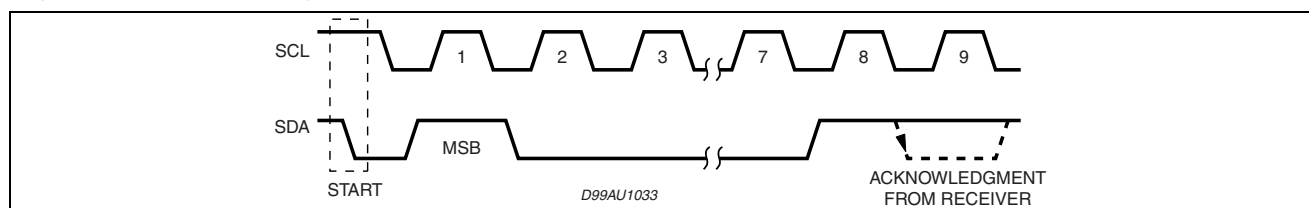

Figure 13. Acknowledge on the I²CBUS



5 SOFTWARE SPECIFICATION

Interface Protocol

The interface protocol comprises:

- A start condition (S)
- A chip address byte, containing the TDA7440D
- A subaddress bytes
- A sequence of data (N byte + acknowledge)
- A stop condition (P)

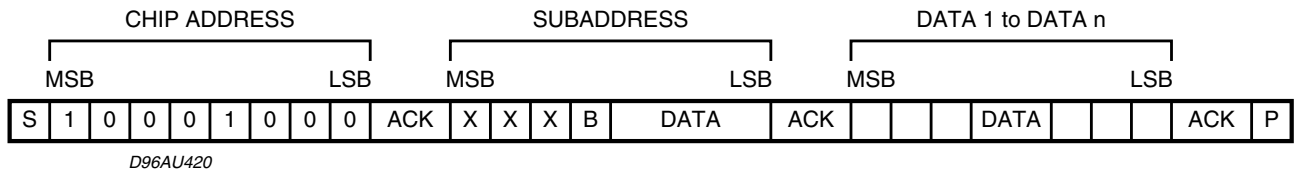

ACK = Acknowledge

S = Start

P = Stop

A = Address

B = Auto Increment

5.1 EXAMPLES

5.1.1 No Incremental Bus

The TDA7440D receives a start condition, the correct chip address, a subaddress with the B = 0 (no incremental bus), N-datas (all these data concern the subaddress selected), a stop condition.

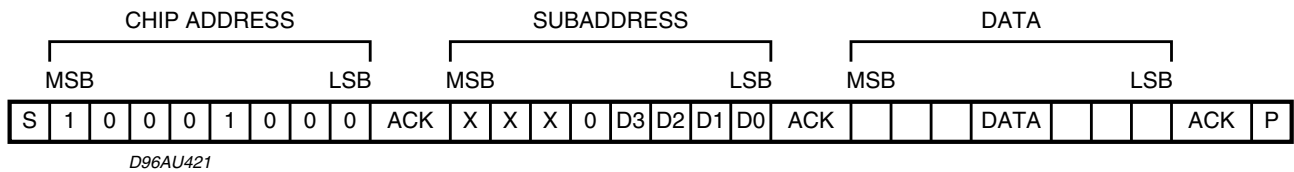

5.1.2 Incremental Bus

The TDA7440D receive a start conditions, the correct chip address, a subaddress with the B = 1 (incremental bus): now it is in a loop condition with an autoincrease of the subaddress whereas SUBADDRESS from "XXX1000" to "XXX1111" of DATA are ignored.

The DATA 1 concern the subaddress sent, and the DATA 2 concerns the subaddress sent plus one sent in the loop etc, and at the end it receives the stop condition.

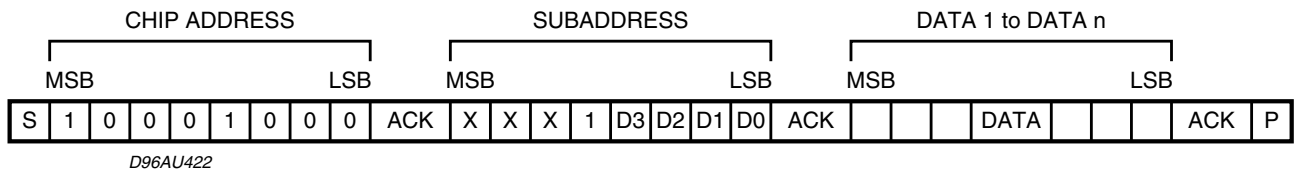

5.2 POWER ON RESET CONDITION

Table 6.

INPUT SELECTION	IN2
INPUT GAIN	28dB
VOLUME	MUTE
BASS	0dB
TREBLE	2dB
SPEAKER	MUTE

5.3 DATA BYTES

Address = 88 HEX (ADDR:OPEN).

Table 7. FUNCTION SELECTION: First byte (subaddress)

MSB								LSB	SUBADDRESS
D7	D6	D5	D4	D3	D2	D1	D0		
X	X	X	B	0	0	0	0	INPUT SELECT	
X	X	X	B	0	0	0	1	INPUT GAIN	
X	X	X	B	0	0	1	0	VOLUME	
X	X	X	B	0	0	1	1	BASS	
X	X	X	B	0	1	0	0	NOT USED	
X	X	X	B	0	1	0	1	TREBLE	
X	X	X	B	0	1	1	0	SPEAKER ATTENUATE "R"	
X	X	X	B	0	1	1	1	SPEAKER ATTENUATE "L"	

B = 1: INCREMENTAL BUS ACTIVE

B = 0: NO INCREMENTAL BUS

X = DON'T CARE

In Incremental Bus Mode, the "not used" function must be addressed in any case. For example to refresh "Volume = 0dB" and Speaker_R = -40dB", the following bytes must be sent:

Table 8.

SUBADDRESS	XXX10010
VOLUME DATA	X0000000
BUS DATA	XXXX1111
NOT USED DATA	XXXX1111
TREBLE DATA	XXXX1111
SPEAKER_R DATA	X0000010

Table 9. INPUT SELECTION

MSB								LSB	INPUT MULTIPLEXER
D7	D6	D5	D4	D3	D2	D1	D0		
X	X	X	X	X	X	0	0	IN4	
X	X	X	X	X	X	0	1	IN3	
X	X	X	X	X	X	1	0	IN2	
X	X	X	X	X	X	1	1	IN1	

5.3 DATA BYTES (continued)

Table 10. INPUT GAIN SELECTION

MSB							LSB		INPUT GAIN
D7	D6	D5	D4	D3	D2	D1	D0	2dB STEPS	
				0	0	0	0	0dB	
				0	0	0	1	2dB	
				0	0	1	0	4dB	
				0	0	1	1	6dB	
				0	1	0	0	8dB	
				0	1	0	1	10dB	
				0	1	1	0	12dB	
				0	1	1	1	14dB	
				1	0	0	0	16dB	
				1	0	0	1	18dB	
				1	0	1	0	20dB	
				1	0	1	1	22dB	
				1	1	0	0	24dB	
				1	1	0	1	26dB	
				1	1	1	0	28dB	
				1	1	1	1	30dB	

GAIN = 0 to 30dB

Table 11. VOLUME SELECTION

MSB							LSB		VOLUME
D7	D6	D5	D4	D3	D2	D1	D0	1dB STEPS	
					0	0	0	0dB	
					0	0	1	-1dB	
					0	1	0	-2dB	
					0	1	1	-3dB	
					1	0	0	-4dB	
					1	0	1	-5dB	
					1	1	0	-6dB	
					1	1	1	-7dB	
	0	0	0	0				0dB	
	0	0	0	1				-8dB	
	0	0	1	0				-16dB	
	0	0	1	1				-24dB	
	0	1	0	0				-32dB	
	0	1	0	1				-40dB	
	X	1	1	1	X	X	X	MUTE	

VOLUME = 0 to 47dB/MUTE

5.3 DATA BYTES (continued)

Table 12. BASS SELECTION

MSB							LSB		BASS
D7	D6	D5	D4	D3	D2	D1	D0	2dB STEPS	
				0	0	0	0	-14dB	
				0	0	0	1	-12dB	
				0	0	1	0	-10dB	
				0	0	1	1	-8dB	
				0	1	0	0	-6dB	
				0	1	0	1	-4dB	
				0	1	1	0	-2dB	
				0	1	1	1	0dB	
				1	1	1	1	0dB	
				1	1	1	0	2dB	
				1	1	0	1	4dB	
				1	1	0	0	6dB	
				1	0	1	1	8dB	
				1	0	1	0	10dB	
				1	0	0	1	12dB	
				1	0	0	0	14dB	

Table 13. TREBLE SELECTION

MSB							LSB		TREBLE
D7	D6	D5	D4	D3	D2	D1	D0	2dB STEPS	
				0	0	0	0	-14dB	
				0	0	0	1	-12dB	
				0	0	1	0	-10dB	
				0	0	1	1	-8dB	
				0	1	0	0	-6dB	
				0	1	0	1	-4dB	
				0	1	1	0	-2dB	
				0	1	1	1	0dB	
				1	1	1	1	0dB	
				1	1	1	0	2dB	
				1	1	0	1	4dB	
				1	1	0	0	6dB	
				1	0	1	1	8dB	
				1	0	1	0	10dB	
				1	0	0	1	12dB	
				1	0	0	0	14dB	

5.3 DATA BYTES (continued)

Table 14. SPEAKER ATTENUATE SELECTION

MSB							LSB	SPEAKER ATTENUATION
D7	D6	D5	D4	D3	D2	D1	D0	1dB
					0	0	0	0dB
					0	0	1	-1dB
					0	1	0	-2dB
					0	1	1	-3dB
					1	0	0	-4dB
					1	0	1	-5dB
					1	1	0	-6dB
					1	1	1	-7dB
	0	0	0	0				0dB
	0	0	0	1				-8dB
	0	0	1	0				-16dB
	0	0	1	1				-24dB
	0	1	0	0				-32dB
	0	1	0	1				-40dB
	0	1	1	0				-48dB
	0	1	1	1				-56dB
	1	0	0	0				-64dB
	1	0	0	1				-72dB
	1	1	1	1	X	X	X	MUTE

Figure 14. PINS: 23

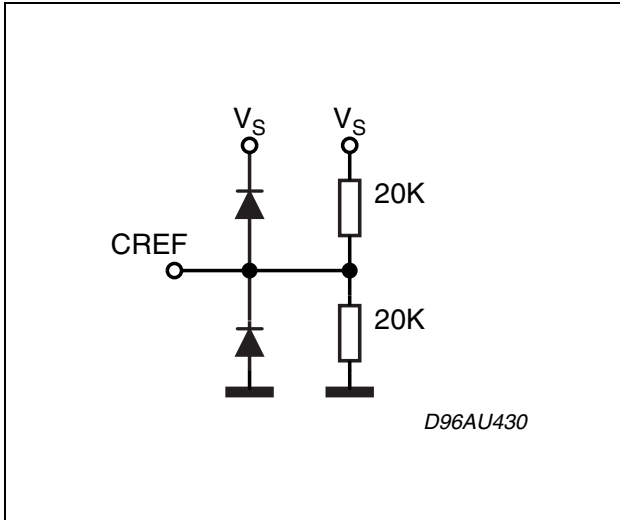

Figure 17. PINS: 8, 10

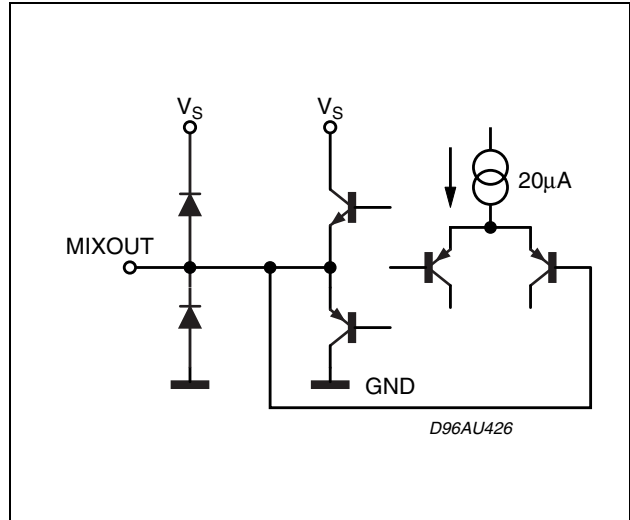

Figure 15. PINS: 26, 27

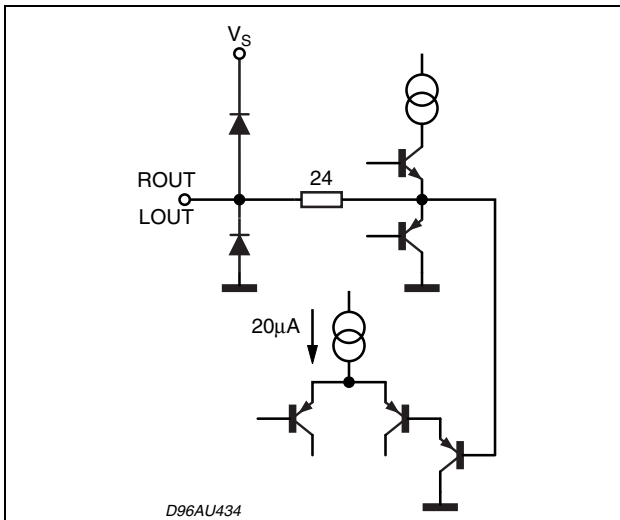

Figure 18. PINS: 19, 11

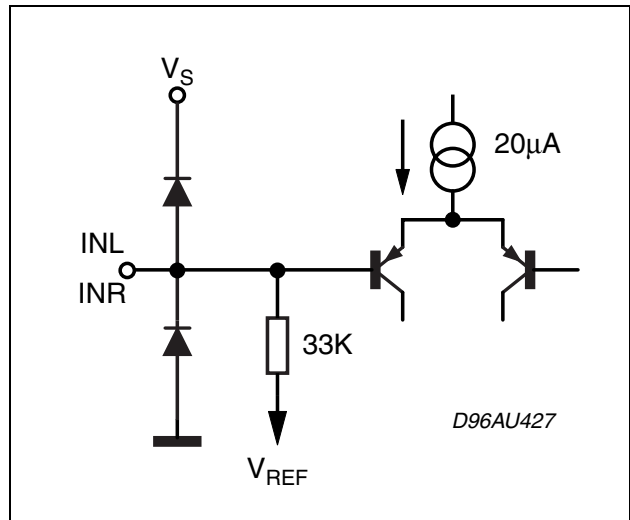

Figure 16. PINS: 1, 2, 3, 4, 5, 6, 7, 28

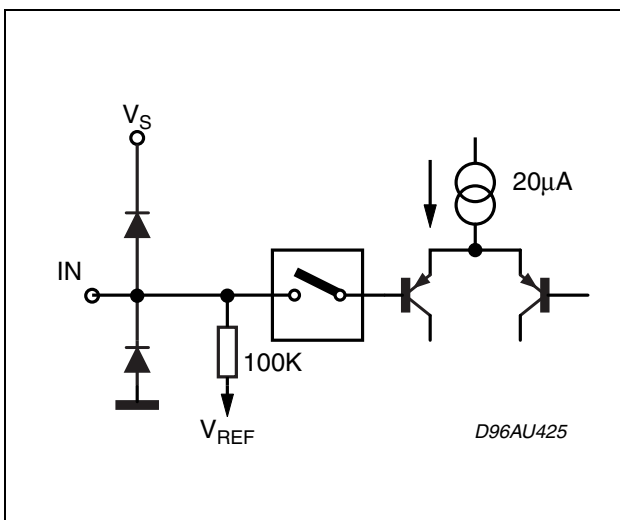

Figure 19. PINS: 12, 14

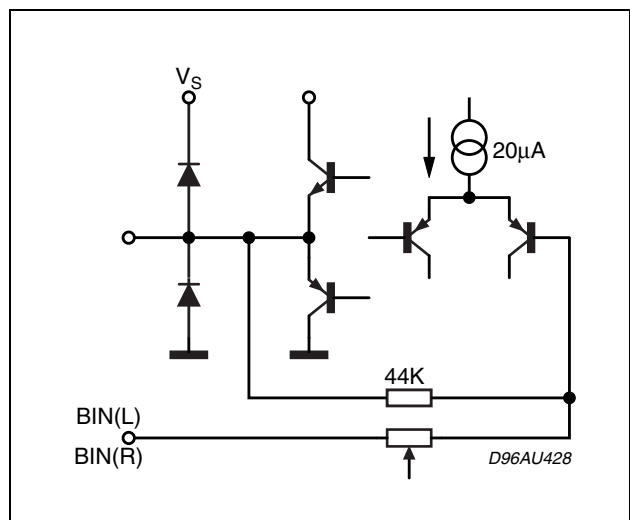

Figure 20. PINS: 13, 15

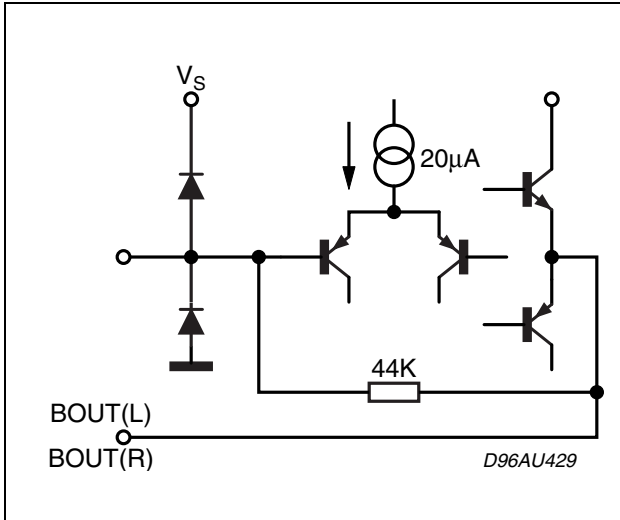

Figure 22. PIN: 20

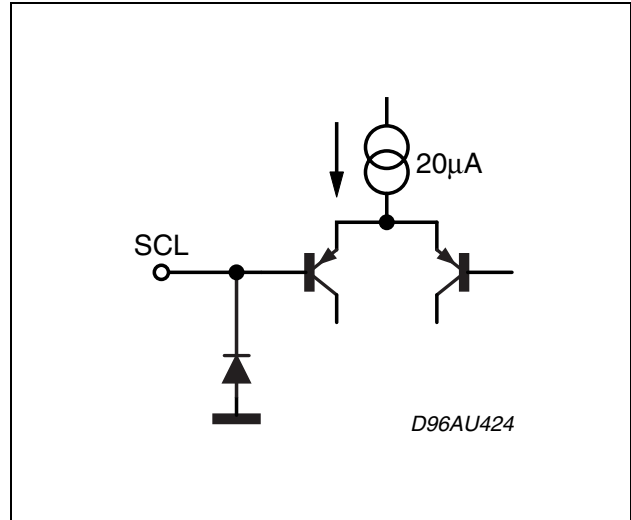

Figure 21. PINS: 18, 19

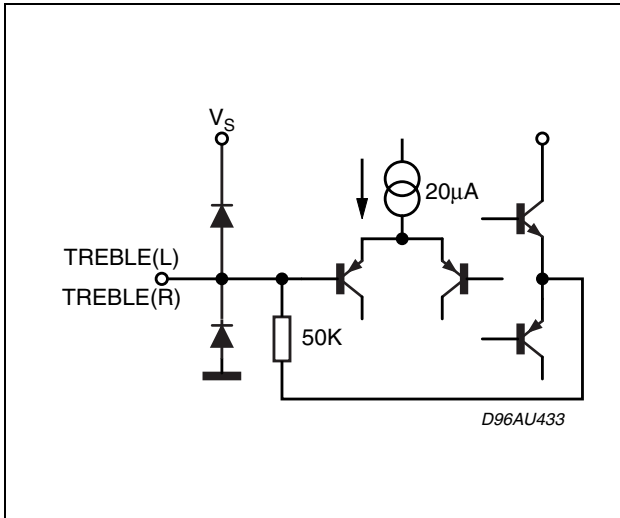
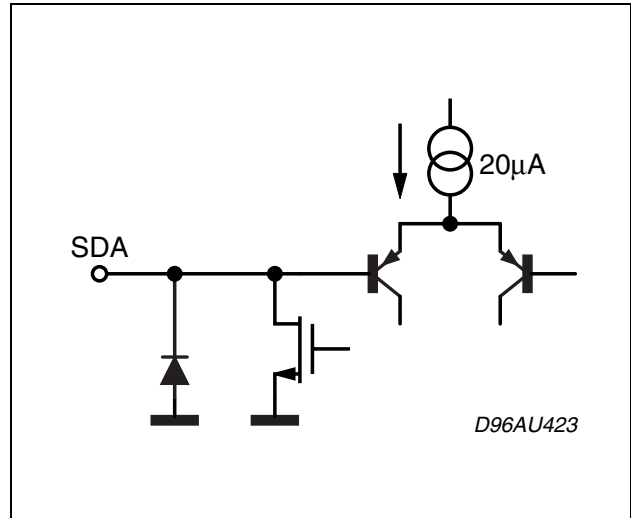

Figure 23. PIN 21



6 PACKAGE MECHANICAL DATA

In order to meet environmental requirements, ST offers these devices in different grades of ECOPACK[®] packages, depending on their level of environmental compliance. ECOPACK[®] specifications, grade definitions and product status are available at: www.st.com. ECOPACK[®] is an ST trademark.

Figure 24. SO-28 Mechanical Data & Package Dimensions

DIM.	mm			inch		
	MIN.	TYP.	MAX.	MIN.	TYP.	MAX.
A			2.65			0.104
a1	0.1		0.3	0.004		0.012
b	0.35		0.49	0.014		0.019
b1	0.23		0.32	0.009		0.013
C		0.5			0.020	
c1	45° (typ.)					
D	17.7		18.1	0.697		0.713
E	10		10.65	0.394		0.419
e		1.27			0.050	
e3		16.51			0.65	
F	7.4		7.6	0.291		0.299
L	0.4		1.27	0.016		0.050
S	8° (max.)					

OUTLINE AND MECHANICAL DATA

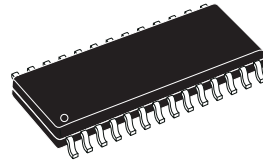

SO-28

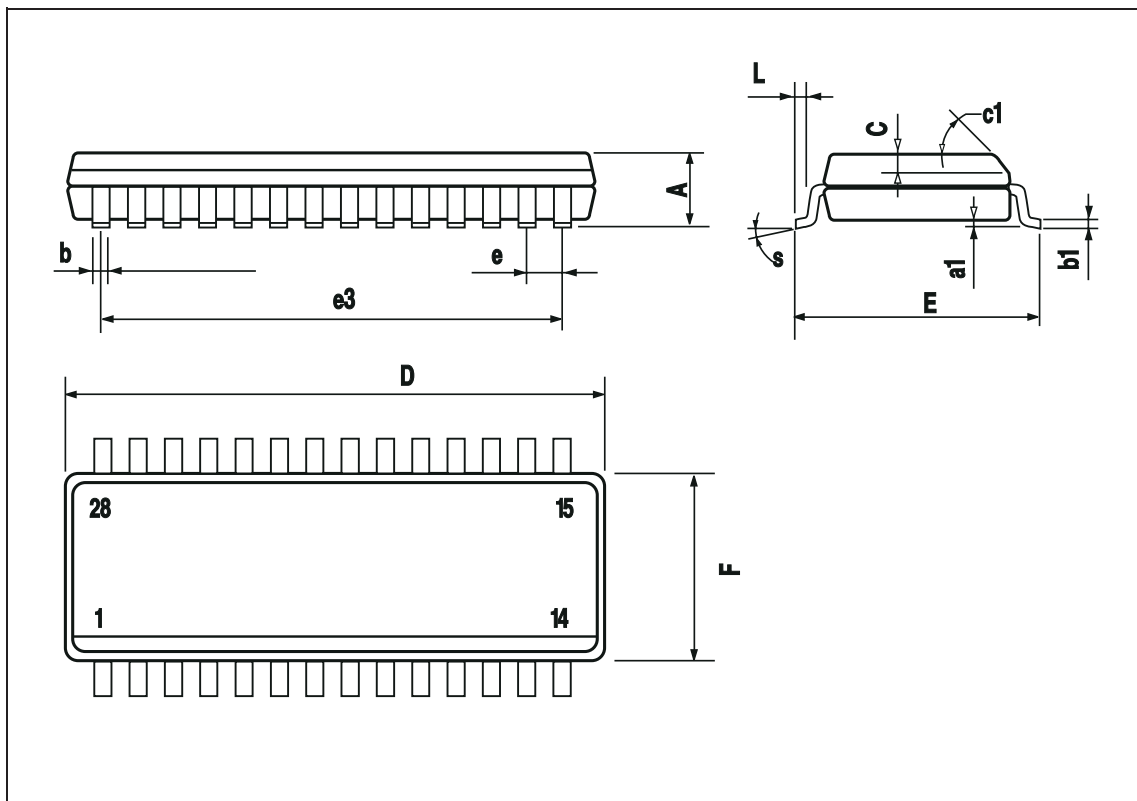

7 REVISION HISTORY

Table 15. Revision History

Date	Revision	Description of Changes
January 2004	2	First Issue
June 2004	3	Modified the style-sheet in compliance with the last revision of the "Corporate Technical Publications Design Guide".
30-Apr-2010	4	Updated title and added environmental compliance statement for package

Please Read Carefully:

Information in this document is provided solely in connection with ST products. STMicroelectronics NV and its subsidiaries ("ST") reserve the right to make changes, corrections, modifications or improvements, to this document, and the products and services described herein at any time, without notice.

All ST products are sold pursuant to ST's terms and conditions of sale.

Purchasers are solely responsible for the choice, selection and use of the ST products and services described herein, and ST assumes no liability whatsoever relating to the choice, selection or use of the ST products and services described herein.

No license, express or implied, by estoppel or otherwise, to any intellectual property rights is granted under this document. If any part of this document refers to any third party products or services it shall not be deemed a license grant by ST for the use of such third party products or services, or any intellectual property contained therein or considered as a warranty covering the use in any manner whatsoever of such third party products or services or any intellectual property contained therein.

UNLESS OTHERWISE SET FORTH IN ST'S TERMS AND CONDITIONS OF SALE ST DISCLAIMS ANY EXPRESS OR IMPLIED WARRANTY WITH RESPECT TO THE USE AND/OR SALE OF ST PRODUCTS INCLUDING WITHOUT LIMITATION IMPLIED WARRANTIES OF MERCHANTABILITY, FITNESS FOR A PARTICULAR PURPOSE (AND THEIR EQUIVALENTS UNDER THE LAWS OF ANY JURISDICTION), OR INFRINGEMENT OF ANY PATENT, COPYRIGHT OR OTHER INTELLECTUAL PROPERTY RIGHT.

UNLESS EXPRESSLY APPROVED IN WRITING BY AN AUTHORIZED ST REPRESENTATIVE, ST PRODUCTS ARE NOT RECOMMENDED, AUTHORIZED OR WARRANTED FOR USE IN MILITARY, AIR CRAFT, SPACE, LIFE SAVING, OR LIFE SUSTAINING APPLICATIONS, NOR IN PRODUCTS OR SYSTEMS WHERE FAILURE OR MALFUNCTION MAY RESULT IN PERSONAL INJURY, DEATH, OR SEVERE PROPERTY OR ENVIRONMENTAL DAMAGE. ST PRODUCTS WHICH ARE NOT SPECIFIED AS "AUTOMOTIVE GRADE" MAY ONLY BE USED IN AUTOMOTIVE APPLICATIONS AT USER'S OWN RISK.

Resale of ST products with provisions different from the statements and/or technical features set forth in this document shall immediately void any warranty granted by ST for the ST product or service described herein and shall not create or extend in any manner whatsoever, any liability of ST.

ST and the ST logo are trademarks or registered trademarks of ST in various countries.

Information in this document supersedes and replaces all information previously supplied.

The ST logo is a registered trademark of STMicroelectronics. All other names are the property of their respective owners.

© 2010 STMicroelectronics - All rights reserved

STMicroelectronics group of companies

Australia - Belgium - Brazil - Canada - China - Czech Republic - Finland - France - Germany - Hong Kong - India - Israel - Italy - Japan - Malaysia - Malta - Morocco - Philippines - Singapore - Spain - Sweden - Switzerland - United Kingdom - United States of America

www.st.com

