

EVALUATION KIT
AVAILABLE

High-Current VCOM Drive Buffers for TFT LCDs

General Description

The MAX9550/MAX9551/MAX9552 provide a VCOM source for TFT LCDs. The MAX9550/MAX9551/MAX9552 source and sink a large current to quickly restore the VCOM voltage, making it ideal for TFT LCDs. The output settles to within 0.1% in less than 2 μ s. In addition, the MAX9550/MAX9551/MAX9552 directly drive the capacitive load in the VCOM layer of the TFT LCDs without the need for a series resistor.

The MAX9550/MAX9551/MAX9552 feature single, dual, and quad channel VCOM amplifiers, respectively. The MAX9550/MAX9551/MAX9552 can drive up to 800mA of peak current per channel and operate up to 20V. The devices feature soft-start to reduce inrush current, output short-circuit protection, and thermal shutdown.

The MAX9550 is available in a space-saving 5-pin thin SOT23 package, and an 8-pin μ MAX[®] package with an exposed paddle. The MAX9551 is available in an 8-pin μ MAX package with an exposed paddle. The MAX9552 is available in a 14-pin TSSOP package. All devices are specified over the -40°C to +85°C temperature range.

Applications

TFT-LCD Panels
Instrument Control Voltage Sources

Pin Configuration appears at end of data sheet.

Features

- ◆ Operates Up To 20V
- ◆ 800mA Peak Output Current
- ◆ Settles to Within 0.1% of V_{OUT} in Less than 2 μ s
- ◆ Excellent Load Regulation
- ◆ Thermal-Shutdown Protection
- ◆ Short-Circuit Protection to Both Rails
- ◆ Soft-Start to Reduce Inrush Current

Ordering Information

PART	AMPS	PIN-PACKAGE	PKG CODE	TOP MARK
MAX9550EZK+T	1	5 Thin SOT23-5	Z5-1	ADSG
MAX9550EUA+	1	8 μ MAX-EP*	U8E-2	AABA
MAX9551EUA+	2	8 μ MAX-EP*	U8E-2	—
MAX9552EUD+	4	14 TSSOP-EP*	U14E-3	—

Note: All devices specified over the -40°C to +85°C operating temperature range.

+Denotes lead-free package.

*EP = Exposed paddle.

Typical Operating Circuit

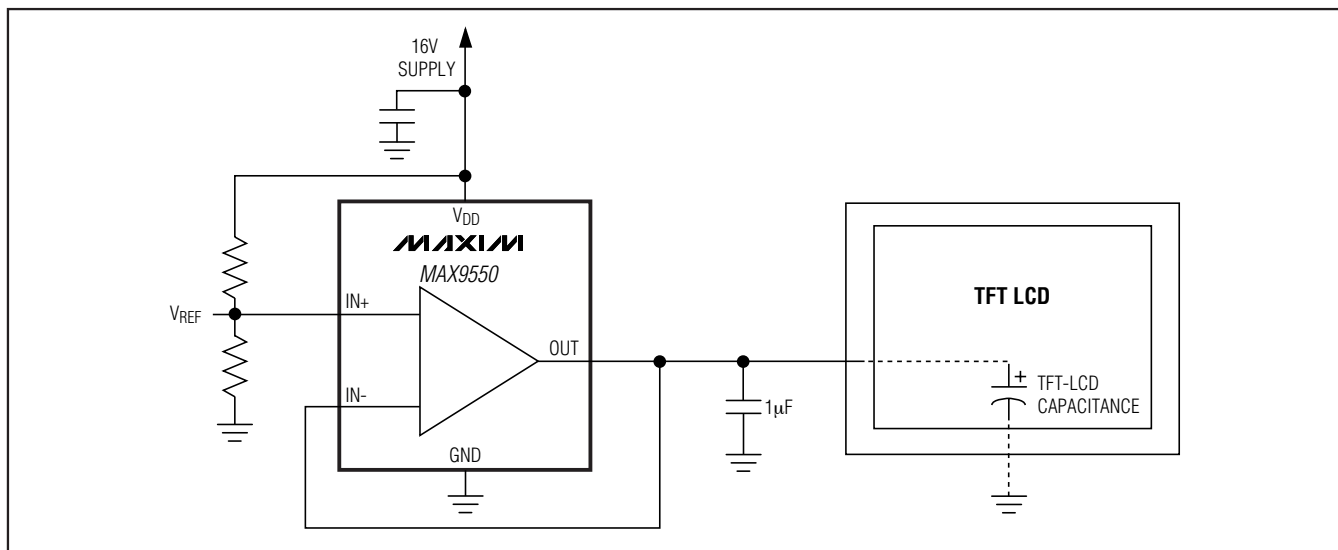

μ MAX is a registered trademark of Maxim Integrated Products, Inc.



Maxim Integrated Products 1

For pricing, delivery, and ordering information, please contact Maxim Direct at 1-888-629-4642, or visit Maxim's website at www.maxim-ic.com.

MAX9550/MAX9551/MAX9552

High-Current VCOM Drive Buffers for TFT LCDs

ABSOLUTE MAXIMUM RATINGS

Supply Voltage (V_{DD} to GND)-0.3V to +22V
 Any Other Pin to GND-0.3V to ($V_{DD} + 0.3V$)
 IN+/IN- (current) $\pm 20mA$
 OUT, OUT_ (current).....1A
 Continuous Power Dissipation ($T_A = +70^\circ C$)
 5-Pin Thin SOT23 (derate 2.7mW/ $^\circ C$ above +70 $^\circ C$) ...219.1mW

8-Pin μ MAX (derate 10.3mW/ $^\circ C$ above +70 $^\circ C$)824.7mW
 14-Pin TSSOP (derate 20.8mW/ $^\circ C$ above +70 $^\circ C$)1667mW
 Operating Temperature Range-40 $^\circ C$ to +85 $^\circ C$
 Junction Temperature+150 $^\circ C$
 Storage Temperature Range-65 $^\circ C$ to +150 $^\circ C$
 Lead Temperature (soldering, 10s)+300 $^\circ C$

Stresses beyond those listed under "Absolute Maximum Ratings" may cause permanent damage to the device. These are stress ratings only, and functional operation of the device at these or any other conditions beyond those indicated in the operational sections of the specifications is not implied. Exposure to absolute maximum rating conditions for extended periods may affect device reliability.

ELECTRICAL CHARACTERISTICS

($V_{DD} = 16V$, GND = 0V, $V_{CM} = V_{OUT} = V_{DD} / 2$, $C_L = 1\mu F$, $T_A = T_{MIN}$ to T_{MAX} , unless otherwise noted. Typical values are at $T_A = +25^\circ C$.) (Note 1)

PARAMETER	SYMBOL	CONDITIONS	MIN	TYP	MAX	UNITS	
DC CHARACTERISTICS							
Supply Voltage Range	V_{DD}	Inferred from PSRR test and transient load test	7		20	V	
Quiescent Current	I_{CC}	Per channel		2	4	mA	
Low Output Voltage	V_{OL}	$I_L = -4mA$		0.04	0.1	V	
High Output Voltage	V_{OH}	$I_H = +4mA$		$V_{DD} - 0.04$	$V_{DD} - 0.1$	V	
Input Offset Voltage	V_{OS}		-10	+1	+10	mV	
Input Bias Current	I_B			0.01	1	μA	
Input Resistance	R_{IN}			1		$M\Omega$	
Common-Mode Input Voltage	CMVR	Inferred from CMRR	2		$V_{DD} - 2$	V	
Common-Mode Rejection Ratio	CMRR	$2V \leq V_{IN} \leq (V_{DD} - 2V)$	80	96		dB	
Power-Supply Rejection Ratio	PSRR	$V_{OUT} = 3.5V$, $V_{DD} = 7V$ to 16V	80	96		dB	
Continuous Output Current	I_O	$V_{DD} = 7V$, $V_{OUT} = 3.5V$, guaranteed by load, regulation test	55			mA	
Output Load Regulation	LR1	$I_{OUT} = 0mA$ to 50mA		6	13	mV	
		$I_{OUT} = 0mA$ to -50mA		6	13		
Output Load Regulation	LR2	$V_{DD} = 7V$, $V_{OUT} = 3.5V$	$I_{OUT} = 0mA$ to -55mA		6.5	15	mV
			$I_{OUT} = 0mA$ to 55mA		6.5	15	
Thermal Shutdown				+160		$^\circ C$	
Thermal Hysteresis				15		$^\circ C$	

High-Current VCOM Drive Buffers for TFT LCDs

MAX9550/MAX9551/MAX9552

ELECTRICAL CHARACTERISTICS (continued)

($V_{DD} = 16V$, $GND = 0V$, $V_{CM} = V_{OUT} = V_{DD} / 2$, $C_L = 1\mu F$, $T_A = T_{MIN}$ to T_{MAX} , unless otherwise noted. Typical values are at $T_A = +25^\circ C$.) (Note 1)

PARAMETER	SYMBOL	CONDITIONS	MIN	TYP	MAX	UNITS
AC CHARACTERISTICS						
Settling Time	t_s	Settling to 0.1% of V_{OUT} , $I_L = 0$ to 600mA, $C_L = 1\mu F$, $R_S = 2.2\Omega$, $C_S = 0.1\mu F$ (Figure 1)		2.0		μs
Input Capacitance	C_{IN}			1.5		pF
Transconductance	gm	$I_{OUT} = \pm 50mA$		13		S
		$I_{OUT} = \pm 500mA$		42		
Transient Output Current	I_{OUTMAX}	$A_v = 1$	$V_{DD} = 7V$, $V_{IN} = 1.5V$ pulse for 100 μs	± 200	± 290	mA
			$V_{DD} = 16V$, $V_{IN} = 1.5V$ pulse for 100 μs	± 600	± 830	

Note 1: All devices are 100% production tested at $T_A = +25^\circ C$. All temperature limits are guaranteed by design.

Typical Operating Characteristics

($V_{DD} = 16V$, $GND = 0V$, $V_{CM} = V_{OUT} = V_{DD} / 2$, $C_L = 1\mu F$, $T_A = +25^\circ C$, unless otherwise noted.)

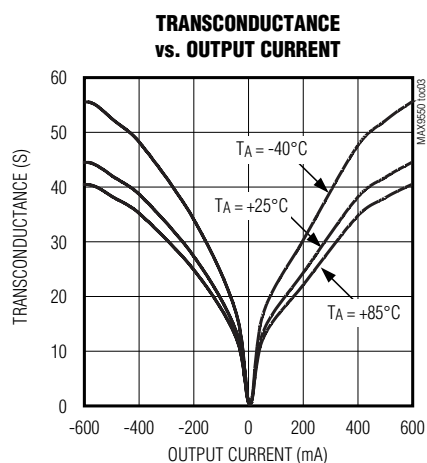
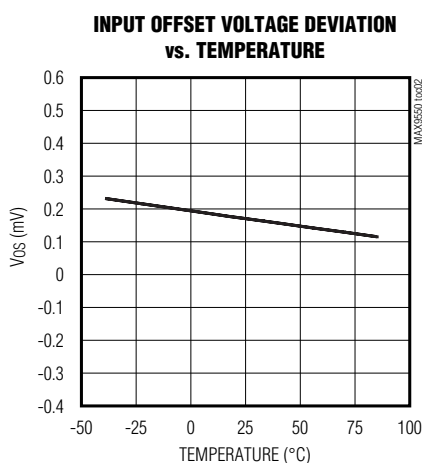
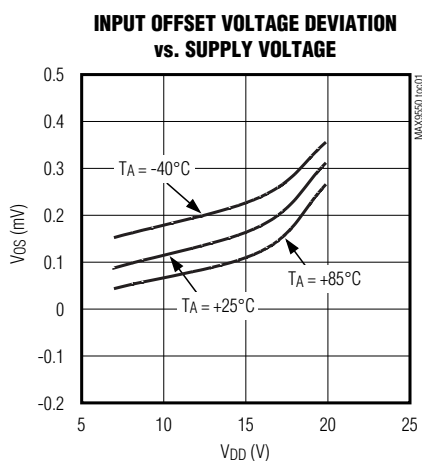

High-Current VCOM Drive Buffers for TFT LCDs

Typical Operating Characteristics (continued)

($V_{DD} = 16V$, $GND = 0V$, $V_{CM} = V_{OUT} = V_{DD} / 2$, $C_L = 1\mu F$, $T_A = +25^\circ C$, unless otherwise noted.)

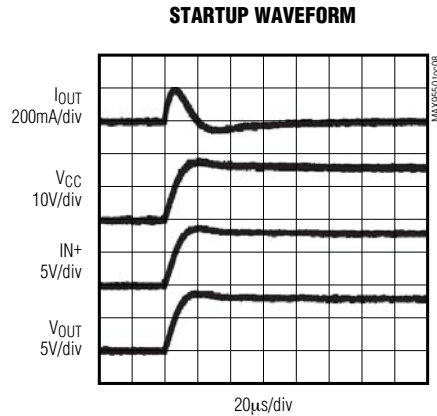
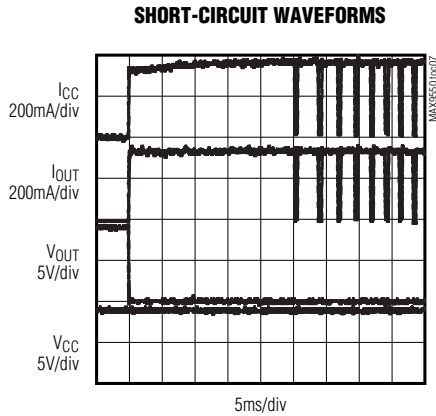
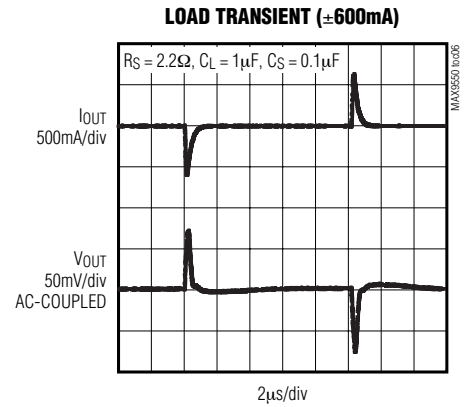
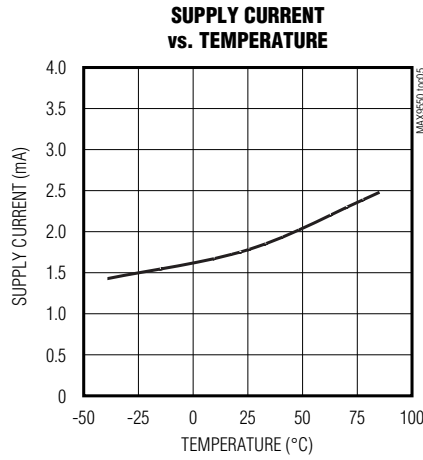
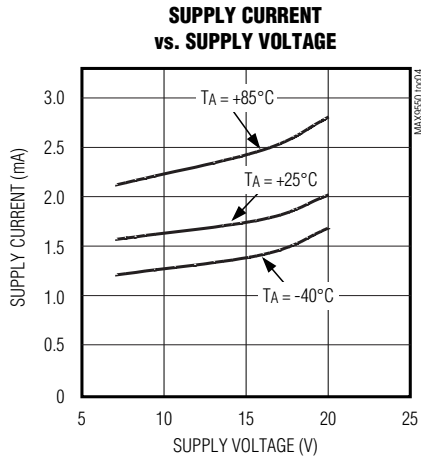

High-Current VCOM Drive Buffers for TFT LCDs

Pin Description

PIN				NAME	FUNCTION
MAX9550		MAX9551	MAX9552		
THIN SOT23	μMAX				
1	6	—	—	OUT	VCOM Output
2	4	4	11	GND	Ground
3	3	—	—	IN+	Positive Input
4	2	—	—	IN-	Negative Input
5	7	8	4	V _{DD}	Positive Supply Input
—	—	1	1	OUTA	VCOM Output A
—	—	3	3	INA+	Positive Input A
—	—	2	2	INA-	Negative Input A
—	1, 5, 8	—	—	N.C.	No Connection. Not internally connected.
—	—	5	5	INB+	Positive Input B
—	—	6	6	INB-	Negative Input B
—	—	7	7	OUTB	VCOM Output B
—	—	—	8	OUTC	VCOM Output C
—	—	—	9	INC-	Negative Input C
—	—	—	10	INC+	Positive Input C
—	—	—	12	IND+	Positive Input D
—	—	—	13	IND-	Negative Input D
—	—	—	14	OUTD	VCOM Output D
—	EP	EP	EP	EP	Exposed Paddle. EP is internally connected to GND. Connect EP to GND.

MAX9550/MAX9551/MAX9552

High-Current VCOM Drive Buffers for TFT LCDs

Detailed Description

The MAX9550/MAX9551/MAX9552 operational transconductance amplifiers (OTA) hold the VCOM voltage stable while providing the ability to source and sink a high current quickly (800mA typ) into a capacitive load such as the backplane of a TFT-LCD panel. The output settles to within 0.1% in less than 2 μ s. The fast settling time is achieved by increasing the transconductance of the buffer as the output current increases (see the *Typical Operating Characteristics*).

In addition, the MAX9550/MAX9551/MAX9552 directly drive the capacitive load in the VCOM layer of the TFT LCD without the need for a series resistor.

The MAX9550/MAX9551/MAX9552 unity-gain bandwidth is:

$$GBW = g_M / 2\pi C_{OUT}$$

where C_{OUT} is the capacitive load at the output and g_M is the transconductance.

To insure buffer stability, place a 1 μ F low-ESR capacitor as close to the OUT pin as possible. However, this value may be reduced if the TFT-LCD panel load provides some of the capacitance and the resistance in series when this capacitance is low. Connect the feedback at OUT using a Kelvin connection at the low-ESR capacitor.

Thermal Shutdown with Temperature Hysteresis

The MAX9550/MAX9551/MAX9552 are capable of high output currents and therefore, feature thermal-shutdown protection with temperature hysteresis. When the die temperature reaches +160°C, the devices shut down. When the die cools down by 15°C, the devices turn on again.

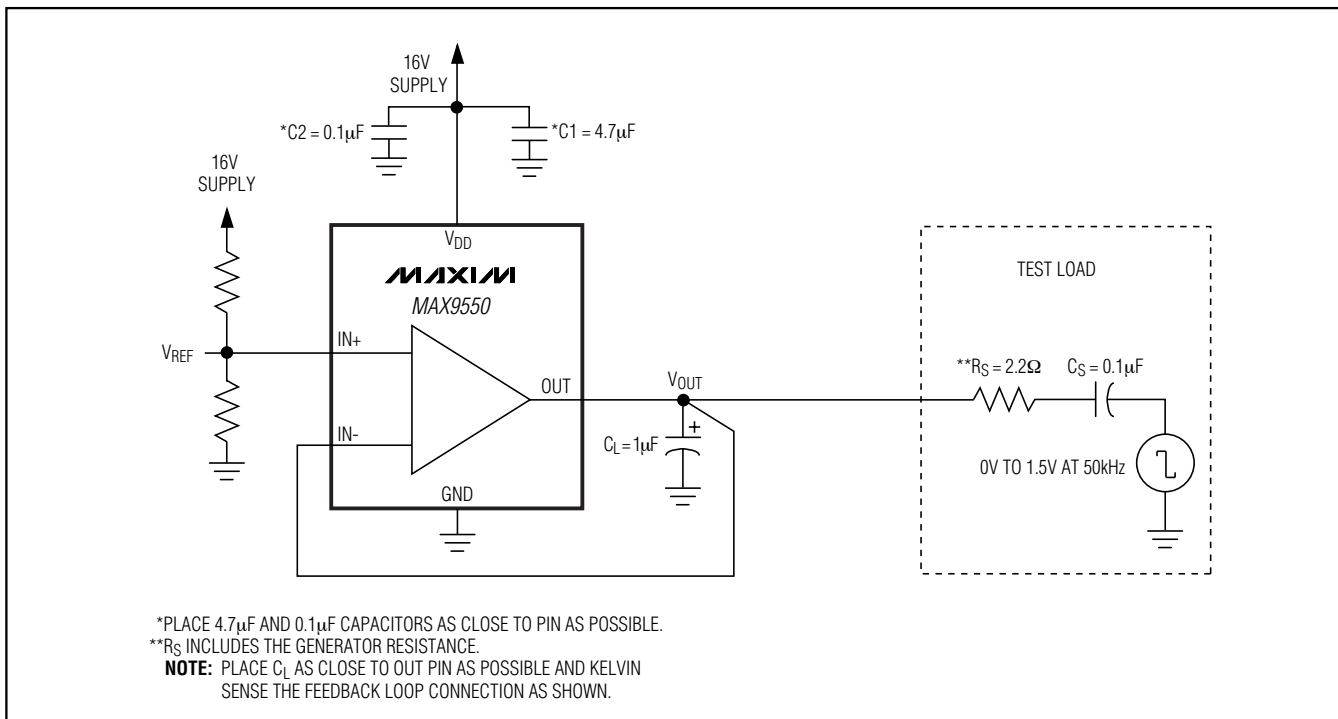

Figure 1. Settling Time Test Circuit

High-Current VCOM Drive Buffers for TFT LCDs

MAX9550/MAX9551/MAX9552

Applications Information

Output Load Capacitor

The output load capacitor must have a low ESR value (50mΩ or lower) and it must be placed as close as possible to the OUT pin to ensure buffer stability (see Figure 2). Ceramic capacitors are an excellent choice.

Power Supplies and Bypass Capacitors

The MAX9550/MAX9551/MAX9552 operate from a 6V to 20V single supply, or from ±3V to ±10V dual supplies. Proper supply bypassing ensures stability while driving high transient loads. The MAX9550/MAX9551/MAX9552 require minimum 4.7μF (C1) and 0.1μF (C2) power-supply bypass capacitors placed as close as possible to

the power-supply pin (V_{DD}). See Figure 2. For dual-supply operation, use 4.7μF and 0.1μF bypass capacitors on both supplies (V_{DD} and GND) with each capacitor placed as close as possible to the V_{DD} and GND pins.

Layout and Grounding

The exposed paddle on the μMAX and TSSOP packages provides a low thermal resistance for heat dissipation. Solder the exposed paddle to a ground plane for best results. Do not route traces under these packages. For dual-supply operation, the exposed paddle (EP) must be electrically connected to the negative supply or it can be left unconnected.

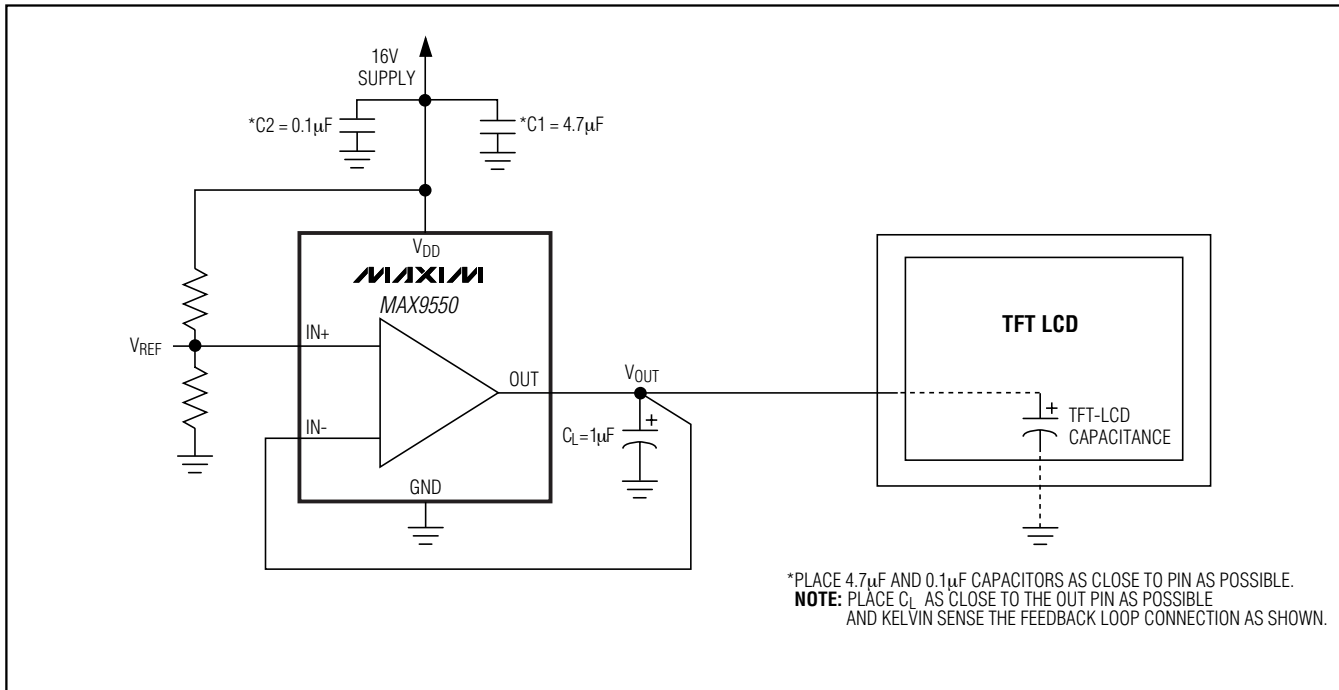
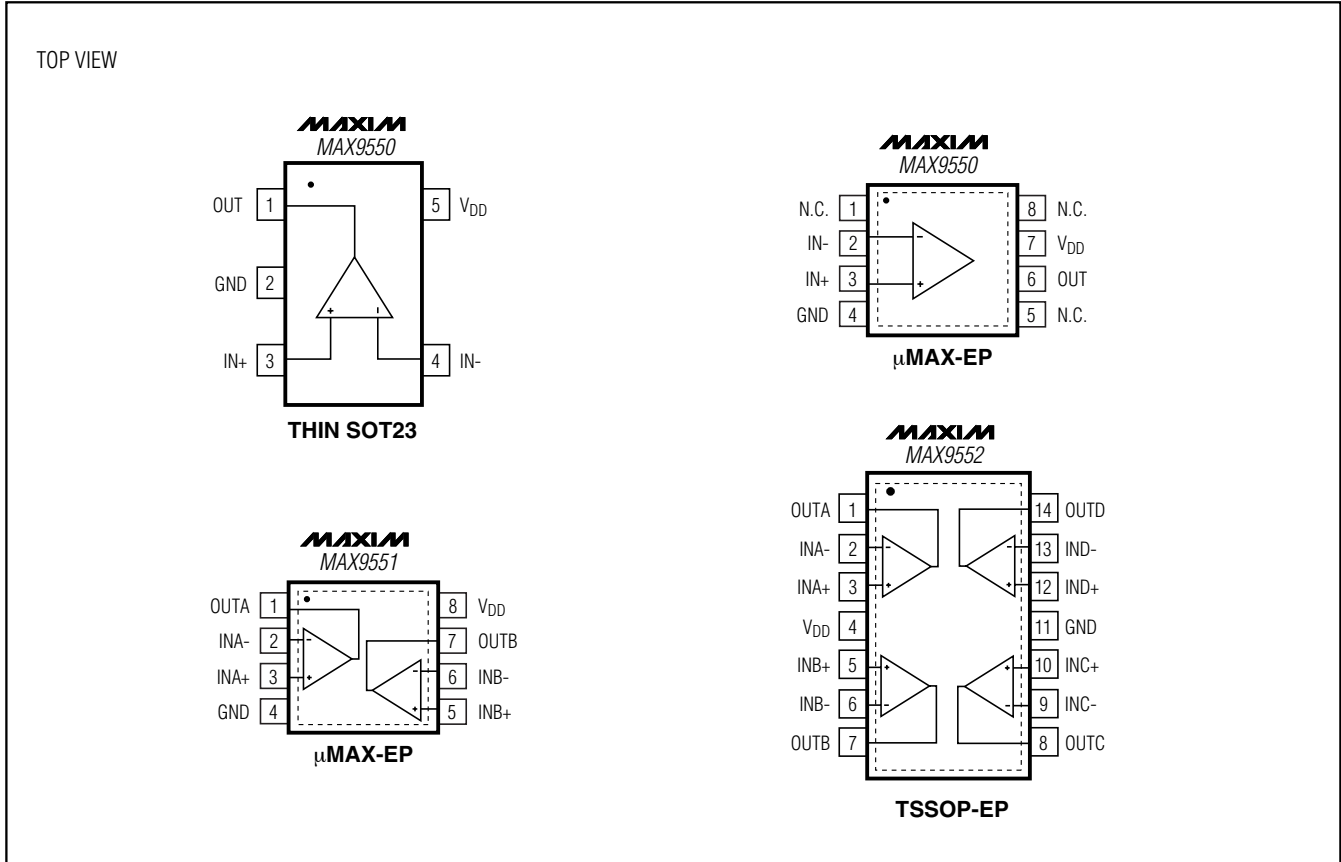

Figure 2. Typical TFT-LCD Backplane Drive Circuit

High-Current VCOM Drive Buffers for TFT LCDs

Pin Configurations



Chip Information

PROCESS: BiCMOS

High-Current VCOM Drive Buffers for TFT LCDs

Package Information

(The package drawing(s) in this data sheet may not reflect the most current specifications. For the latest package outline information go to www.maxim-ic.com/packages.)

MAX9550/MAX9551/MAX9552

THIN SOT23.EPS

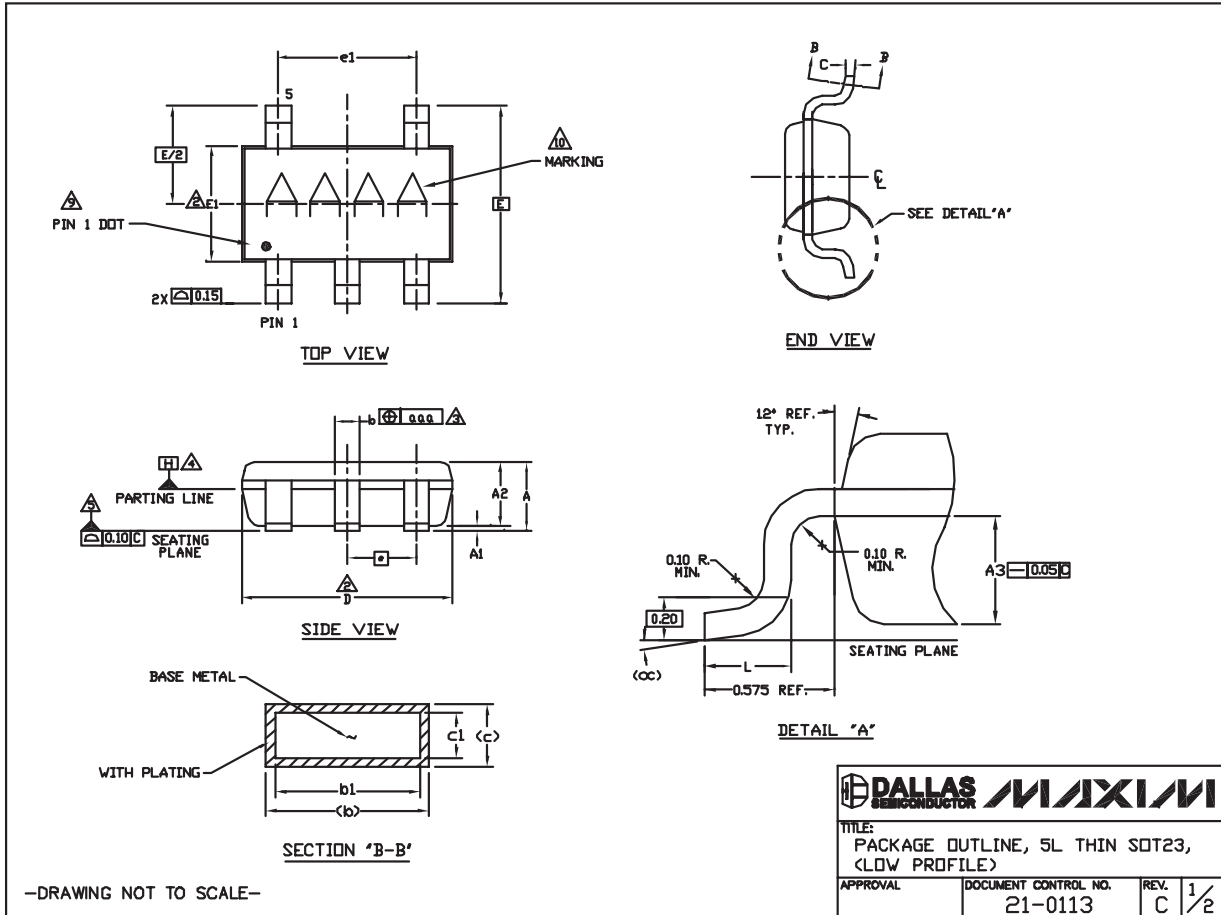

High-Current VCOM Drive Buffers for TFT LCDs

Package Information (continued)

(The package drawing(s) in this data sheet may not reflect the most current specifications. For the latest package outline information go to www.maxim-ic.com/packages.)

NOTES

1. ALL DIMENSIONS ARE IN MILLIMETERS.

2. "D" AND "E1" ARE REFERENCE DATUM AND DO NOT INCLUDE MOLD FLASH OR PROTRUSIONS, AND ARE MEASURED AT THE BOTTOM PARTING LINE. MOLD FLASH OR PROTRUSION SHALL NOT EXCEED 0.15mm ON "D" AND 0.25mm ON "E" PER SIDE.

3. THE LEAD WIDTH DIMENSION DOES NOT INCLUDE DAMBAR PROTRUSION. ALLOWABLE DAMBAR PROTRUSION SHALL BE 0.07mm TOTAL IN EXCESS OF THE LEAD WIDTH DIMENSION AT MAXIMUM MATERIAL CONDITION.

4. DATUM PLANE "H" LOCATED AT MOLD PARTING LINE AND COINCIDENT WITH LEAD, WHERE LEAD EXITS PLASTIC BODY AT THE BOTTOM OF PARTING LINE.

5. THE LEAD TIPS MUST LIE WITHIN A SPECIFIED TOLERANCE ZONE. THIS TOLERANCE ZONE IS DEFINED BY TWO PARALLEL LINES. ONE PLANE IS THE SEATING PLANE, DATUM [C-C-J] AND THE OTHER PLANE IS AT THE SPECIFIED DISTANCE FROM [C-C-J] IN THE DIRECTION INDICATED. FORMED LEADS SHALL BE PLANAR WITH RESPECT TO ONE ANOTHER WITH 0.10mm AT SEATING PLANE.

6. THIS PART IS COMPLIANT WITH JEDEC SPECIFICATION MO-193 EXCEPT FOR THE "e" DIMENSION WHICH IS 0.95mm INSTEAD OF 1.00mm. THIS PART IS IN FULL COMPLIANCE TO EIAJ SPECIFICATION SC-74.

7. COPLANARITY APPLIES TO THE EXPOSED PAD AS WELL AS THE TERMINALS. COPLANARITY SHALL NOT EXCEED 0.08mm.

8. WARPAGE SHALL NOT EXCEED 0.10mm.

9. THE TERMINAL #1 IDENTIFIER AND TERMINAL NUMBERING CONVENTION SHALL CONFORM TO JEDEC 95-1 PP-012. DETAILS OF TERMINAL #1 IDENTIFIER ARE OPTIONAL. THE TERMINAL #1 IDENTIFIER MAY BE EITHER A MOLD OR MARKED FEATURE.

10. MARKING IS FOR PACKAGE ORIENTATION REFERENCE ONLY.

11. ALL DIMENSIONS APPLY TO BOTH LEADED (←) AND LEAD FREE (→) PACKAGE CODES.

SYMBOLS			
	MIN	NOM	MAX
A	-	-	1.10
A1	0.00	0.075	0.10
A2	0.85	0.88	0.90
A3	0.50 BSC		
b	0.30	-	0.45
b1	0.25	0.35	0.40
c	0.15	-	0.20
c1	0.12	0.127	0.15
D	2.80	2.90	3.00
E	2.75 BSC		
E1	1.55	1.60	1.65
L	0.30	0.40	0.50
e1	1.90 BSC		
e	0.95 BSC		
OC	0°	4°	8°
aaa	0.20		
Pkg. codes: Z5-1j Z5-2			

-DRAWING NOT TO SCALE-

TITLE: PACKAGE OUTLINE, 5L THIN SOT23, (LOW PROFILE)			
APPROVAL	DOCUMENT CONTROL NO.	REV.	2/2
	21-0113	C	

High-Current VCOM Drive Buffers for TFT LCDs

Package Information (continued)

(The package drawing(s) in this data sheet may not reflect the most current specifications. For the latest package outline information go to www.maxim-ic.com/packages.)

MAX9550/MAX9551/MAX9552

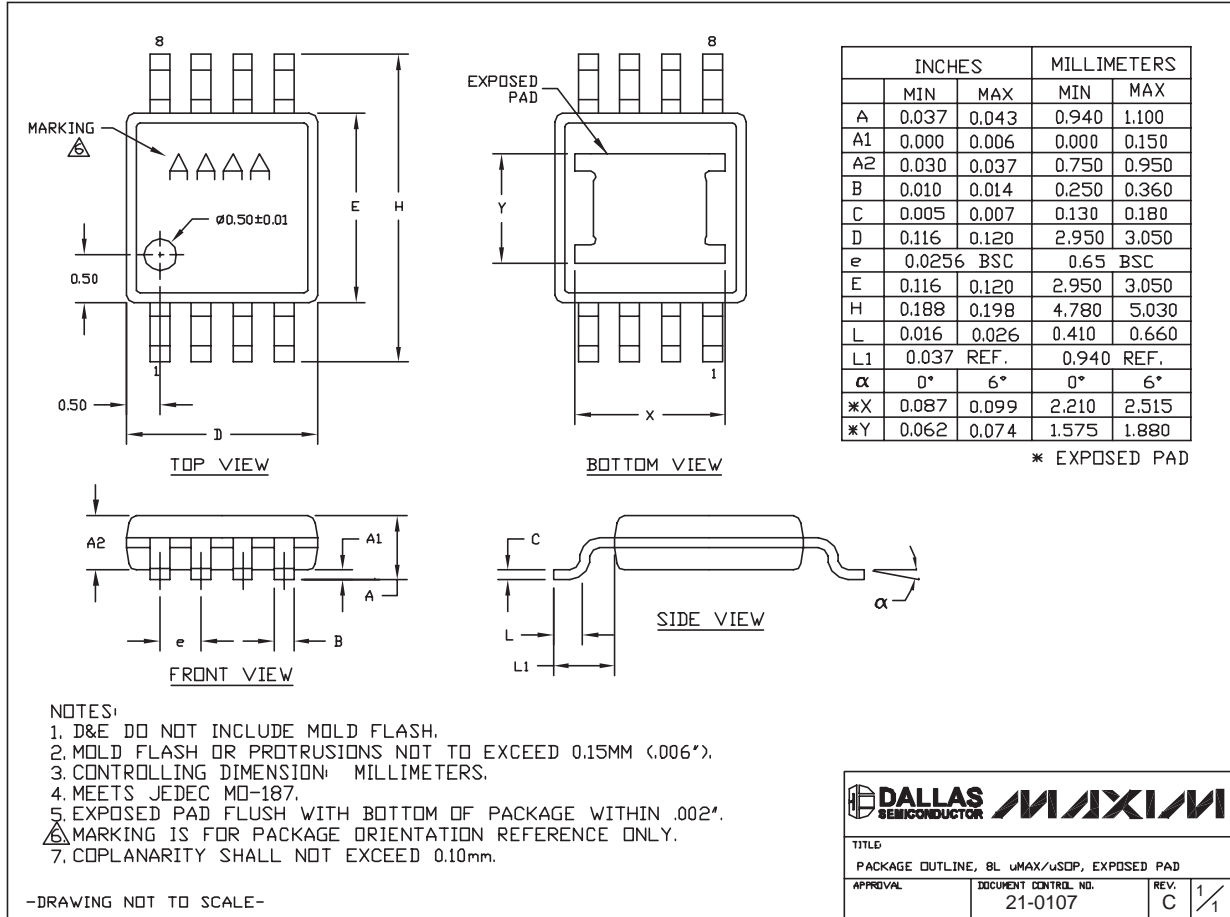

High-Current VCOM Drive Buffers for TFT LCDs

Package Information (continued)

(The package drawing(s) in this data sheet may not reflect the most current specifications. For the latest package outline information go to www.maxim-ic.com/packages.)

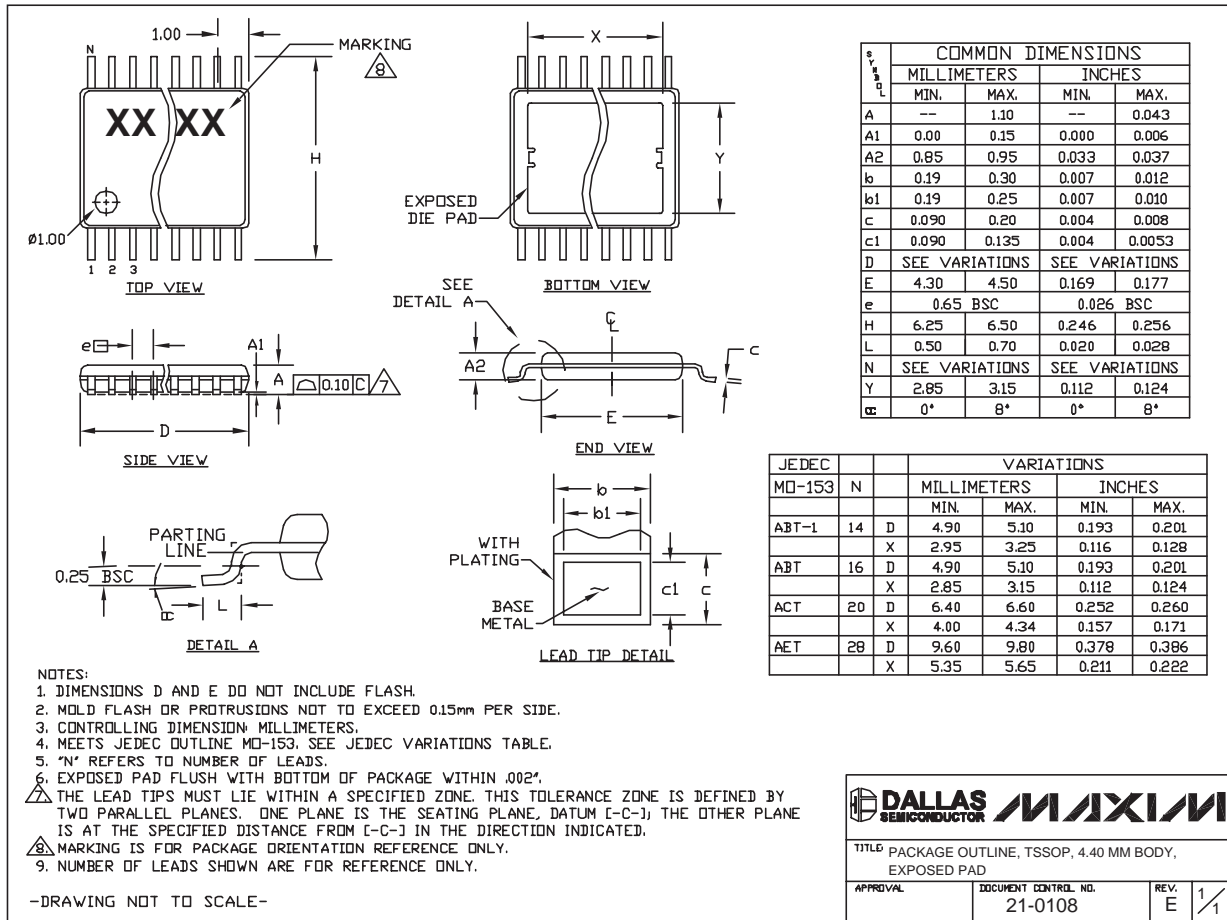

TSSOP 4.4mm BODY, EPS

Revision History

Pages changed at Rev 3: 1, 2, 9, 10, 12

12 Maxim Integrated Products, 120 San Gabriel Drive, Sunnyvale, CA 94086 408-737-7600

© 2007 Maxim Integrated Products

MAXIM is a registered trademark of Maxim Integrated Products, Inc.